

REPAIR MANUAL

5 HP - 24



ZF GETRIEBE GMBH SAARBRÜCKEN

Status 98/08/01

subject to alterations

© Copyright 1998 all rights reserved and published by
ZF Getriebe GmbH, Saarbrücken, Department MKTD

No part of this manual may be reproduced or transmitted in any form or
by any means, electronic or mechanical, including photocopying and recording,
for any purpose without the express written permission of
ZF Getriebe GmbH, Saarbrücken

Printed in Germany

Table of Contents

	Page
Preliminary information	II
1. General information	1.1/1
1.1 Picture of the transmission	1.1/1
1.2 Diagram of power flow	1.2/1
1.3 (Previously used for the oil supply diagrams, not currently used)	
1.4 Making adjustments	1.4/1
1.4.0 Measuring the disc sets (procedure)	1.4/1
1.4.1 Adjusting clearance of brake F (snap ring)	1.4/2
1.4.2 Adjusting clearance of brake D (snap ring)	1.4/4
1.4.3 Adjusting clearance of brake E (snap ring)	1.4/6
1.4.4 Adjusting clearance of clutch C (snap ring)	1.4/8
1.4.5 Adjusting clearance of clutch A (snap ring)	1.4/10
1.4.6 Adjusting clearance of clutch B (snap ring)	1.4/12
1.4.7 Output play (shim)	1.4.14
1.4.8 Input play (shim)	1.4.15
1.4.9 Adjusting switch (detent spring)	1.4.16
1.5 Tightening torques	1.5/1
1.6 Transmission test (test bench/vehicle)	1.6/1
1.7 Special tools	1.7/1
1.8 Function tests	1.8/1
1.8.1 Position switch	1.8/1
2. Disassembly	2.1/1
2.1 Disassembly of the transmission as of the assembly group	2.1/1
2.2 Brake F with freewheel, 1st gear	2.2/1
2.3 Output	2.3/1
2.4 Tower I	2.4/1
2.4.1 Brake D, E and clutch C	2.4/1
2.4.2 Planetary drive (III, II and I)	2.4/6
2.5 Tower II	2.5/1
2.6 Oil supply	2.6/1
2.7 Transmission with flow control valve and breather	2.7/1
2.8 Transmission with selector mechanism and parking lock	2.8/1
3. Assembly	3.1/1
3.1 Transmission with selector mechanism and parking lock	3.1/1
3.2 Brake F with freewheel, 1st gear	3.2/1
3.3 Tower I	3.3/1
3.3.1 Planetary drive (III, II and I)	3.3/1
3.3.2 Brake (E and D)	3.3/4
3.3.3 Assembly, clutch C	3.3/9
3.4 Output	3.4/1
3.5 Tower II (input with clutches A and B)	3.5/1
3.5.1 Clutch A (input)	3.5/1
3.5.2 Clutch B (input)	3.5/3
3.6 Oil supply	3.6/1
3.7 Control unit, oil pan and converter	3.7/1
(Complete control unit, see parts list, technical cover sheet, position Y02)	

Preliminary information

This manual covers the procedure for repairing the complete transmission.

The repairing of this transmission is only allowed to persons with an specific training from ZF Getriebe GmbH.

The entire disassembly and assembly procedure is described in chronological order.

The photographs were kept general in nature so that they can be used with various applications; they are not binding in every case.

We use *Service Bulletines* and training to announce important information and application-specific changes that must be taken into consideration in maintenance work. If this repair manual is given to a third party, there will be no modification service.

The *Service Bulletines* regulations and specifications must be followed when making repairs.

Depending on the type of damage that has occurred, the repair work can be limited to that which is necessary to repair the damage.

Here, you must observe the following:

- Seals (such as O-rings, shaft seals, gaskets and filters) must always be renewed.
- All O-rings, rectangular-section rings, and other sealing rings must always be lubricated with white petroleum jelly before installation.
- All bearings must always be in a slightly oiled condition when installed.
- For transmissions that have been used for a large number of kilometers (> 80,000 km), all lined clutch discs and steel discs must be replaced.
- After clutches/ brakes have been damaged, the converter, oil tubes, and oil cooler, must be cleaned thoroughly.
- If brake F has been damaged, or if a considerable distance has been covered (> 150,000 km), piston F must be replaced.

The following requirements should be met before the repair work is started:

- The required special tools should be available.
(The complete set of special tools is listed in Chapter 1.7)
- A suitable transmission testing rig should be available.
The required testing values can be found in the *Service Bulletines*.

Note:

This manual treats the automatic control unit as a complete unit, which should not be disassembled without special knowledge; it should be exchanged as a complete unit.

A separate repair manual is planned for the automatic control unit.

Important:

The transmission is filled with life-time oil.

The oil does not have to be changed until it has been in use for ten years.

The transmission may only be delivered with the oil type and oil amount specified in the corresponding parts list documentation (see ELCAT), otherwise there is danger of gearbox failure.

Techn. After Sales Service

Techn. Documentation

After Sales Service School

Bach

Reus

Schultz

1. General information

1.1 Picture of the transmission



1.2 Power flow diagram

Gang = Gear ratio

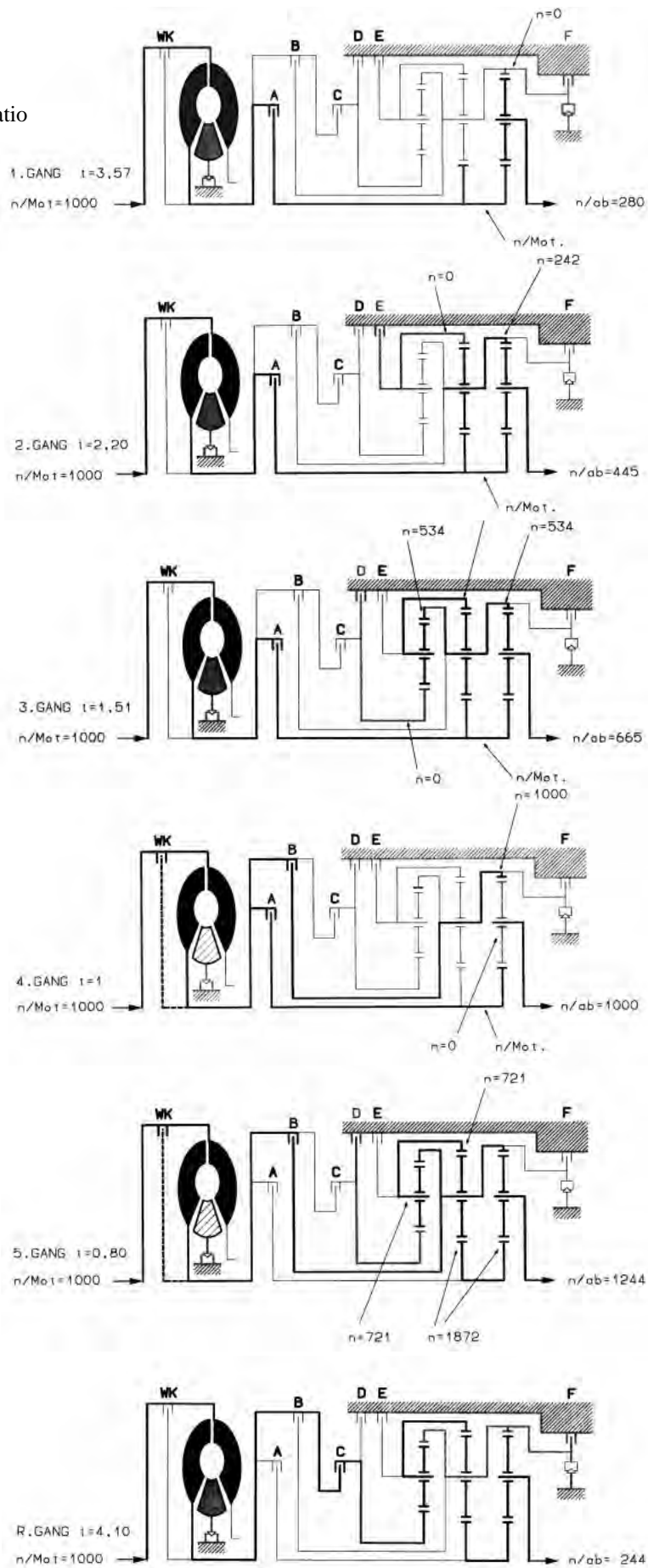

Zf 5hp24 1 Repair Manual Cardiagncom

Full download: <http://manualplace.com/download/zf-5hp24-1-repair-manual-cardiagncom/>