

# SHOP MANUAL

# YANMAR

Models YM135, YM135D, YM155, YM155D, YM195, YM195D,  
YM240, YM240D, YM330 and YM330D

Tractor serial number is stamped on left side of clutch housing on transmission housing. Engine model and serial number is located on a data plate attached to right side of engine for YM135, YM135D, YM155 and YM155D models. Engine model and serial number is located on a data plate attached to left side of engine for YM195, YM195D, YM240, YM240D, YM330 and YM330D models.

## INDEX (By Starting Paragraph)

	YM135, YM135D	YM155, YM155D	YM195, YM195D	YM240, YM240D	YM330, YM330D
<b>BRAKES</b> .....	210	210	210	210	210
<b>CLUTCH</b> .....	130	130	130	130	130
<b>COOLING SYSTEM</b> .....	115	115	115	115	115
<b>DIESEL FUEL SYSTEM</b>					
Filters & Bleeding .....	85	85	85	85	85
Nozzles .....	90	90	90	90	90
Thermostart .....	97	97	97	97	97
Timing .....	86	86	88	88	88
<b>DIFFERENTIAL</b>					
Front .....	16	16	21	21	31
Rear .....	185	185	190	190	195
<b>ELECTRICAL SYSTEM</b>					
Alternator & Regulator .....	120	120	121	121	121
Starter .....	125	125	125	125	125
<b>ENGINE</b>					
Camshaft .....	60	60	61	61	61
Connecting Rods .....	71	71	71	71	71
Crankshaft .....	72	72	72	72	73
Cylinder Head .....	45	45	45	45	45
Flywheel .....	78	78	78	78	78
Oil Pump .....	80	80	80	80	80
Pistons & Rings .....	66	66	66	66	66
Remove & Reinstall .....	42	42	42	42	42
Tappet Adjustment .....	47	47	47	47	47
Timing Gears .....	56	56	57	57	57
Valves & Seats .....	48	48	48	48	48
<b>FINAL DRIVE</b>					
Front .....	15	15	20	20	30
Rear .....	200	200	202	202	204
<b>FRONT AXLE</b>					
Four Wheel Drive .....	4	4	4	4	4
Two Wheel Drive .....	1	1	1	1	1
<b>FRONT WHEEL DRIVE</b> .....	15	15	20	20	30
<b>GOVERNOR</b> .....	101	101	103	103	103
<b>HYDRAULIC SYSTEM</b> .....	240	240	240	240	240
<b>POWER TAKE OFF</b> .....	215	215	220	220	230
<b>STEERING GEAR</b> .....	10	10	10	10	10
<b>TRANSMISSION</b> .....	150	150	160	160	170

This service manual provides specifications in both the Metric (SI) and U.S. Customary systems of measurement. The first specification is given in the measuring system used during manufacture, while the second specification (given in parenthesis) is the converted measurement. For instance, a specification of "0.28 mm (0.011 inch)" would indicate that the equipment was manufactured using the metric system of measurement and the U.S. equivalent of 0.28 mm is 0.011 inch.



# CONDENSED SERVICE DATA

GENERAL	YM135, YM135D	YM155, YM155D	YM195, YM195D	YM240, YM240D	YM330, YM330D
Engine Make .....	OWN				
Engine Model .....	2T73A	2TR13A	2T84A	2TR20A-X	3T84A or 3T84A-LP
Number of Cylinders .....	2	2	2	2	3
Bore - mm (in.) .....	73(2.87)	75(2.95)	84(3.31)	90(3.54)	84(3.31)
Stroke - mm (in.) .....	75(2.95)	75(2.95)	90(3.54)	90(3.54)	90(3.54)
Displacement - cc .....	627	662	997	1145	1496
Cubic Inches .....	38.26	40.39	60.84	69.87	91.29
Transmission -					
Speeds Forward .....	6	6	8	8	8
Speeds Reverse .....	2	2	2	2	2
<b>TUNE-UP</b>					
Firing Order .....	1-2	1-2	1-2	1-2	1-3-2
Number 1 Cyl. ....			Rear		
Valve Tappet Gap - Cold					
Exhaust - mm (in.) .....	0.2(0.008)	0.2(0.008)	0.15(0.006)	0.15(0.006)	0.15(0.006)
Inlet - mm (in.) .....	0.2(0.008)	0.2(0.008)	0.15(0.006)	0.15(0.006)	0.15(0.006)
Horsepower at pto .....	...	...	...	19.8	...
Battery - Volts .....	12	12	12	12	12
Polarity Ground .....	Neg.	Neg.	Neg.	Neg.	Neg.
<b>CAPACITIES - All capacities are in liters and (quarts).</b>					
Cooling System .....	3.2(3.4)	3.2(3.4)	4.6(4.9)	4.6(4.9)	6.2(6.5)
Engine Crankcase .....	2.2(2.3)	2.4(2.5)	4.0(4.2)	4.0(4.2)	6.4(6.8)
Front Drive Axle .....	3.0(3.2)	3.0(3.2)	5.0(5.3)	6.0(6.3)	7.0(7.4)
Fuel Tank .....	9.5(10)	15(15.8)	22(23.2)	22(23.2)	32(33.8)
Transmission, Hydraulic System and Rear Axle -					
Two Wheel Drive .....	9.5(10)	9.5(10)	15(15.8)	15(15.8)	20(21)
Four Wheel Drive .....	9(9.5)	9(9.5)	15(15.8)	15(15.8)	20(21)

## FRONT AXLE AND STEERING GEAR

### FRONT AXLE ASSEMBLY

#### Two Wheel Drive Models

1. **ADJUSTMENT.** Refer to appropriate Fig. 1, 2, 2A or 3 for exploded view of fixed or adjustable tread non-driving axle. Toe-in should be 4-8 mm (5/32-5/16 in.) for all models. Length of drag link should be adjusted to provide equally sharp turns in both directions.

Front axle should not have excessive front to rear clearance at pivot shaft (5). Excessive clearance can be removed from YM195 and YM240 models by relocating brackets (29-Fig. 2) closer together. Be sure all attaching screws are retightened after adjustment is complete. On all other models, adjust axle play at pivot by tightening the castle nut (2-Fig. 1 or 3) on pivot shaft. Be sure to

install cotter pin to prevent nut from loosening after adjustment is complete.

Front wheel bearings should be removed, cleaned, inspected and renewed if damaged or repacked with new grease after each 300 hours of operation. Tighten the hub retaining castle nut, then lock position by installing cotter pin. Tighten wheel lug bolts to 78-98 N·m (57.5-72.3 ft.-lbs.) torque.

#### 2. REMOVE AND REINSTALL.

Support front of tractor and disconnect drag link from steering arm. On YM135 and YM155 models, remove cotter pin and castle nut (2-Fig. 1) from axle pivot shaft, support axle with jack, then remove washer (3) and pivot shaft (5). On YM195 and YM240 models, support axle with jack, unbolt pivot brackets (29-Fig. 2 or 2A) from frame, then

lower axle. On YM330 models, support axle with jack, remove cotter pin from castle nut at rear of pivot shaft, then loosen castle nut (2-Fig. 3). Remove self locking nut (39), washer (38), sleeve (37) and snap ring (36), then withdraw the pivot shaft.

When assembling YM135 model, castle nut (2-Fig. 1) should be toward rear. On YM155 model, castle nut is toward front. Bushings (4) are 25 mm (0.984 in.) long for YM135 models; 24 mm (0.945 in.) long for YM155 models. Tighten castle nut (2) on YM135 and YM155 models enough to remove all axle play; however, axle should move smoothly and freely on pivot.

3. **OVERHAUL.** The steering spindle (18-Fig. 1, 2, 2A and 3) is equipped with renewable bushings (13) and some



Paragraph 3 Cont.

models are equipped with bearings (15 and 33). Inside diameter of bushings (13) should be sufficient to provide correct clearance for the spindle. Adjust spindle end play by adding covers (11 - Fig. 1, 2 or 2A) or shims (40 - Fig. 3) as required.

**YM135, YM155**

- Spindle diameter at bushing ..... 24.948-25.0 mm (0.9822-0.9843 in.)
- Spindle to bushing clearance, Desired ..... 0.020-0.124 mm (0.0008-0.0049 in.)
- Wear limit ..... 0.4 mm (0.0157 in.)
- Spindle end play, Desired ..... 0.02-0.086 mm (0.0008-0.0011 in.)
- Wear limit ..... 1.0 mm (0.0394 in.)
- Center pivot pin diameter ..... 21.947-21.980 mm (0.8641-0.8654 in.)

- Center pivot to bushing clearance, Desired ..... 0.040-0.123 mm (0.00157-0.0048 in.)
- Wear limit ..... 0.4 mm (0.0157 in.)
- Axle end play on center pin ..... 0.0-0.5 mm (0-0.0197 in.)

**YM195, YM240**

- Spindle diameter at bushing ..... 24.948-25.0 mm (0.9822-0.9843 in.)
- Spindle to bushing clearance, Desired ..... 0.020-0.122 mm (0.0008-0.0049 in.)
- Wear limit ..... 0.25 mm (0.0098 in.)
- Spindle end play, Desired ..... 0.02-0.86 mm (0.0008-0.0011 in.)
- Wear limit ..... 1.0 mm (0.0394 in.)

- Center pivot pin diameter ..... 24.967-25.0 mm (0.9830-0.9843 in.)
- Center pivot to bushing clearance, Desired ..... 0.020-0.105 mm (0.0008-0.0041 in.)
- Wear limit ..... 0.4 mm (0.0157 in.)
- Axle end play on center pin, Desired ..... 0.1-0.3 mm (0.004-0.011 in.)
- Maximum limit ..... 0.5 mm (0.0197 in.)

**YM330**

- Spindle diameter at bushing ..... 29.959-29.980 mm (1.1735-1.1803 in.)
- Spindle to bushing clearance, Desired ..... 0.020-0.074 mm (0.0008-0.0029 in.)
- Wear limit ..... 0.25 mm (0.0098 in.)
- Spindle end play, Desired ..... 0.02-0.6 mm (0.0008-0.0236 in.)
- Wear limit ..... 0.7 mm (0.0276 in.)

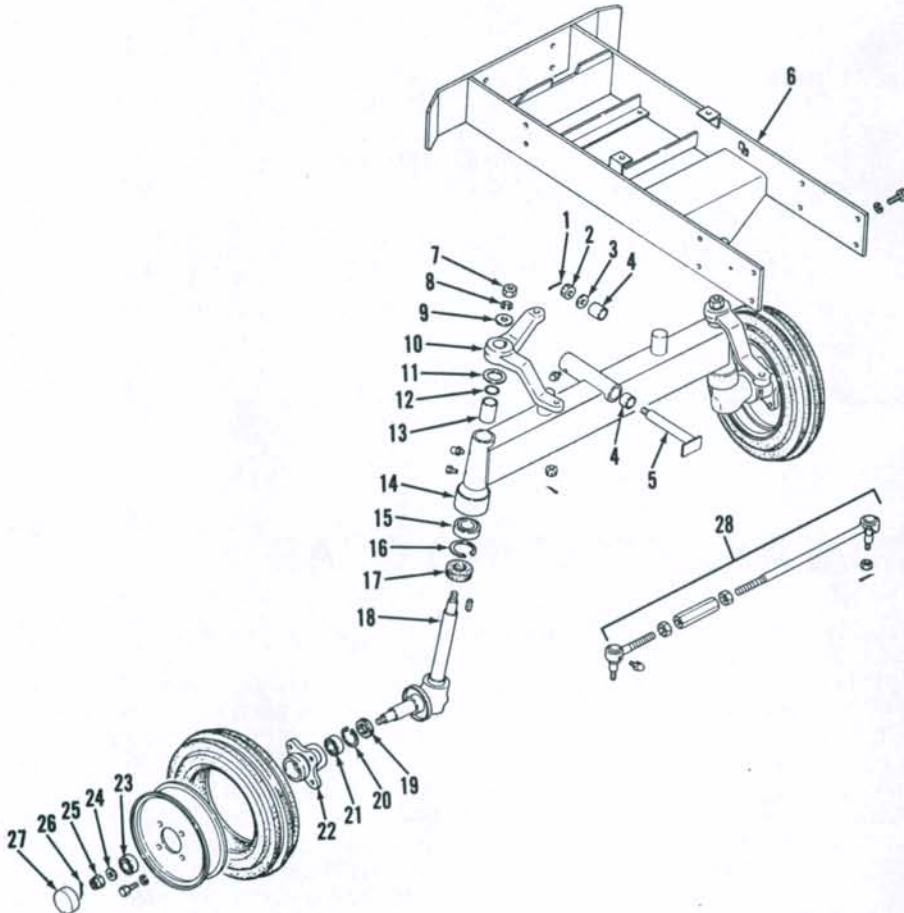

Fig. 1 - Exploded view of non-adjustable front axle used on YM155 models. Axle used on YM135 is similar.

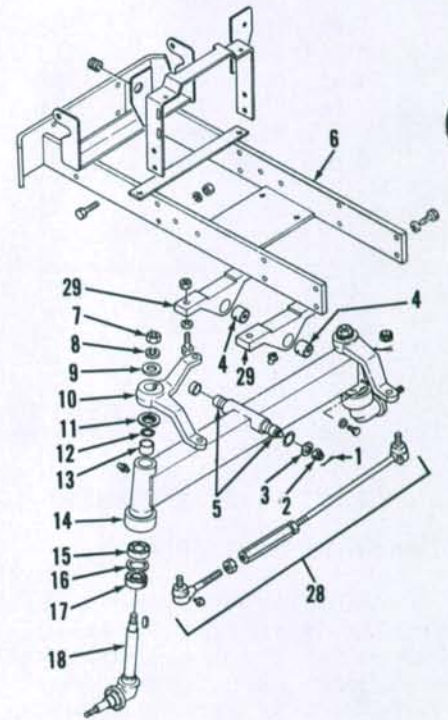

Fig. 2 - Exploded view of standard non-adjustable front axle used on some YM195 and YM240 models. Refer to Fig. 1 for wheel hub and bearings. Refer to Fig. 2A for optional adjustable axle and heavy duty axle.

- |  |                            |                         |                           |
|--|----------------------------|-------------------------|---------------------------|
| 1. Cotter pin  | 9. Plain washer            | 19. Seal                | 1. Cotter pin             |
| 2. Castle nut  | 10. Steering arm           | 20. Snap ring           | 2. Castle nut             |
| 3. Washer  | 11. Cover washer (40x3 mm) | 21. Ball bearing (6205) | 3. Washer                 |
| 4. Bushings (25x24 mm for YM135, 25x25 mm for YM155) | 12. "O" ring               | 22. Hub                 | 4. Bushings (25x25 mm)    |
| 5. Pivot shaft                                       | 13. Bushing (29x38 mm)     | 23. Ball bearing (6204) | 5. Pivot shaft            |
| 6. Frame   | 14. Axle main member       | 24. Plain washer        | 6. Frame                  |
| 7. Nut   | 15. Ball bearing (6205)    | 25. Castle nut          | 7. Nut                    |
| 8. Lockwasher  | 16. Snap ring              | 26. Cotter pin          | 8. Lockwasher             |
|  | 17. Seal                   | 27. Cap                 | 9. Plain washer           |
|  | 18. Spindle                | 28. Tie rod Assy.       | 10. Steering arm          |
|  |                            |                         | 11. Cover                 |
|  |                            |                         | 12. "O" ring              |
|  |                            |                         | 13. Bushing (29x38 mm)    |
|  |                            |                         | 14. Axle main member      |
|  |                            |                         | 15. Ball bearing (6205)   |
|  |                            |                         | 16. Washer (42x51.8x1 mm) |
|  |                            |                         | 17. Seal                  |
|  |                            |                         | 18. Spindle               |
|  |                            |                         | 28. Tie rod               |
|  |                            |                         | 29. Pivot bracket         |



Center pivot pin diameter . . . . .	34.95-34.975 mm (1.3760-1.3770 in.)
Center pivot to bushing clearance, Desired . . . . .	0.025-0.089 mm (0.0010-0.0035 in.)
Wear limit . . . . .	0.4 mm (0.0157 in.)
Axle end play on center pin, Desired . . . . .	0.1-0.3 mm (0.0039-0.0118 in.)
Maximum limit . . . . .	0.5 mm (0.0197 in.)

**Four Wheel Drive**

4. **ADJUSTMENT.** Refer to appropriate paragraphs 15 through 31 for service to individual units. Toe-in should be 4-8 mm for all models.

5. **REMOVE AND REINSTALL.** To remove the front axle from four wheel drive models, first block rear wheels. Loosen the drive shaft cover clamps, remove retaining screws, then move drive shaft cover out of the way. Detach drive shaft from front axle drive pinion. On all models except YM135D and YM155D models, be careful not to lose the steel balls from drive shaft collars. On all models, detach drag link from steering arm. Support weight of tractor by attaching overhead hoist to front weight support, then remove both front wheels. Place a jack under center of front axle to support axle securely when attaching screws are removed.

On all models, except YM330D, remove castle nut from axle pivot, then withdraw pivot shaft. Be careful to prevent axle from falling when pivot is

removed, then lower axle away from tractor.

On YM330D models, disconnect battery cables, then remove battery. Remove locknuts (N-Fig. 4) from screws which attach front axle pivot brackets to frame. Remove all eight screws which attach axle pivot brackets to frame, then lower axle away from tractor.

When installing, reverse removal procedure. Be especially careful to prevent axle from slipping from jack while attaching center pivot.

On all models except YM330D, locate axle in correct position, then install center pivot pin. Nut should be toward rear for YM135D models, toward front for YM155D models. Tighten castle nut on YM135D and YM155D models enough to remove all end play, but be sure that axle pivots freely. Install cotter pin through castle nut to maintain adjustment. On YM195D and YM240D models, shims (54-Fig. 23) should be added to provide axle with less than 0.6 mm (0.0236 in.) end play. Axle must be free to move and not bind. Coat threads of the four screws which retain pivot pin with locking compound after selecting correct thickness of shims.

On YM330D models, coat threads of screws which retain axle pivot brackets with a locking compound and tighten to 149 N·m (109.9 ft.-lbs.) torque. End play of axle in center pivot brackets is adjusted by changing thickness of thrust spacers (54-Fig. 23). End play should be less than 0.6 mm (0.0236 in.), but should not cause binding. Thrust spacers (54) are available in 2.0, 2.3 and 2.6 mm thicknesses.

**STEERING GEAR**

**All Models**

10. **REMOVE AND REINSTALL.** Remove cap from center of steering wheel, remove steering wheel retaining nut, then use puller to remove steering wheel shaft. Disconnect battery ground cable from battery. Remove the battery from YM135 models. On all models remove the instrument panel and the fuel tank. Detach drag link from steering arm, then unbolt, and remove the steering gear assembly.

Reinstall steering gear, reversing the removal procedure. Coat threads of attaching screws with sealer before installing.

11. **OVERHAUL.** Remove cap screws attaching side cover (16-Fig. 5 or Fig. 6) to housing (21), remove locknut (14), then turn adjusting screw (15) in to push cover away from housing. Loosen nut (25) and turn shaft (6) until gear on shaft (19) is aligned with opening in

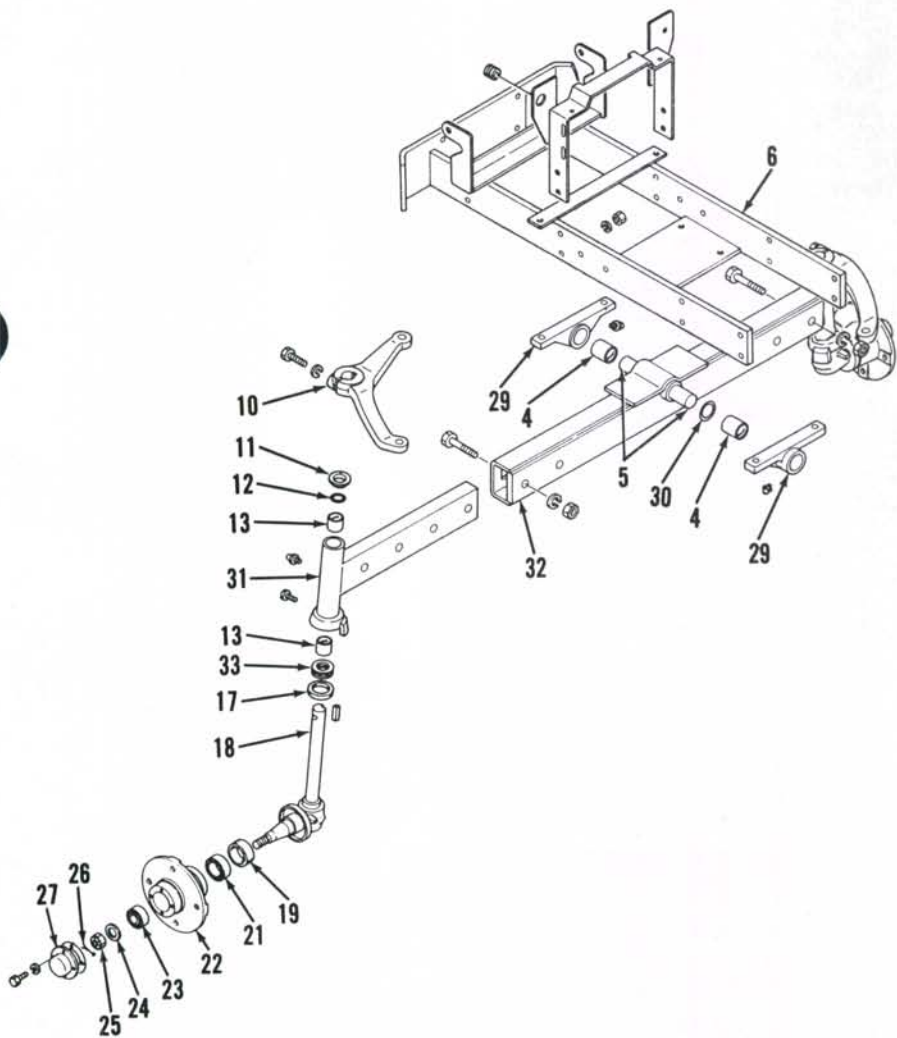

Fig. 2A—Exploded view of adjustable axle available for YM195 and YM240 models. Except for adjustable width feature, heavy duty non-adjustable axle is similar.

- |                        |                           |                            |
|------------------------|---------------------------|----------------------------|
| 4. Bushings (30x40 mm) | 18. Spindle               | 26. Cotter pin             |
| 6. Frame               | 19. Seal                  | 27. Cap                    |
| 10. Steering arm       | 21. Taper bearing (32007) | 29. Pivot bracket          |
| 11. Cover              | 22. Hub                   | 30. Shim                   |
| 12. "O" ring           | 23. Taper bearing (30205) | 31. Axle extension         |
| 13. Bushing            | 24. Plain washer          | 32. Axle center member     |
| 17. Seal               | 25. Castle nut            | 33. Thrust bearing (51106) |



Paragraph 11 Cont.

housing. Remove adjusting screw (15), then bump end of shaft (19) out toward right. After steering arm (24) is released from end of shaft, remove nut (25) and steering arm, then withdraw shaft (19) from housing. Unbolt steering column (12), then withdraw shaft (6) and ball nut (8).

Bushings (22) are available only as an assembly with housing (21). Seal (23) should be flush with housing. Inner race for ball bearings (7) is integral with shaft (6) and disassembly is not recommended. Clean ball nut (8) without disassembling and check for smoothness. Ball nut is available only as an assembly with shaft (6). Apply grease liberally to shaft and ball nut. Grease lower bearing (7) and position in bearing race located in housing. Grease upper bearing (7) and locate on shaft (6). Position shaft (6) with ball nut (8) and upper bearing in housing (21). Position column (12) over shaft and select thickness of shims (13) which will permit free movement of shaft in bearings (7) with no end play of shaft. Install column (12) with sealing "O" ring (9) after selecting correct thickness of shims (13).

Turn shaft (6) until ball nut (8) is in center of travel. Coat cross shaft (19) with grease, then install with center tooth in center valley of ball nut. Position adjustment screw (15) and shim (18) in end of shaft and gasket (20) on housing, then install cover (16). Turn adjusting screw (15) out through cover (16) while installing, then tighten the cover attaching screws to 23-30 N·m (16.96-22.13 ft.-lbs.) torque. Be sure that adjusting screw (15) remains loose while tightening the cover attaching screws. Install steering arm (24) over shaft splines with index marks aligned. Some models have a missing spline to assist alignment of steering arm. Adjust screw (15) to provide 30-50 mm (1 3/16-2 in.) free play at rim of steering wheel, then lock adjustment with nut (4). Initial adjustment can be accomplished by turning screw clockwise as far as possible, then backing screw up 1/4-turn and lock with nut (14). Wear is indicated if play at rim exceeds 50 mm (2 in.) with correct adjustment of screw (15) and correct thickness of shims (13).

Steering gear should be filled with SAE 90 gear lubricant. Capacity is 20 mL for YM135, YM135D, YM155 and YM155D. Capacity is 26 mL for other models.

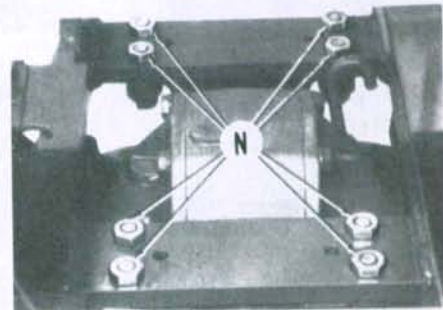

Fig. 4 - View of nuts (N) used to lock the screws that attach front drive axle brackets to frame of YM330D models. Nuts are located under battery bracket.

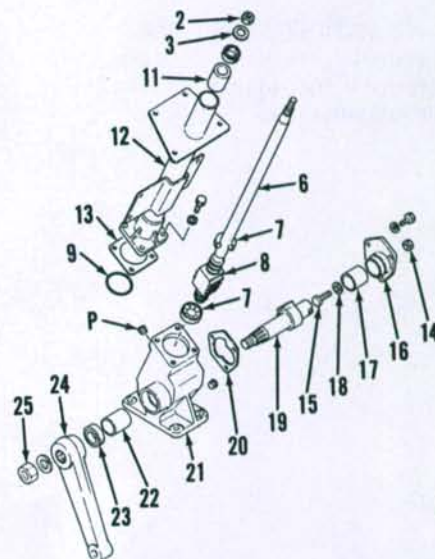

Fig. 5 - Exploded view of steering gear typical of type used on YM135, YM135D, YM155 and YM155D models.

- |                     |                                 |
|---------------------|---------------------------------|
| P. Plug             | 16. Side cover                  |
| 2. Nut              | 17. Bushing                     |
| 3. Washer           | 18. Shim                        |
| 6. Steering shaft   | 19. Sector gear and cross shaft |
| 7. Bearings         | 20. Gasket                      |
| 8. Ball nut         | 21. Housing                     |
| 9. "O" ring         | 22. Bushing                     |
| 11. Bushing         | 23. Seal                        |
| 12. Column          | 24. Steering arm                |
| 13. Shims           | 25. Nut                         |
| 14. Locknut         |                                 |
| 15. Adjusting screw |                                 |

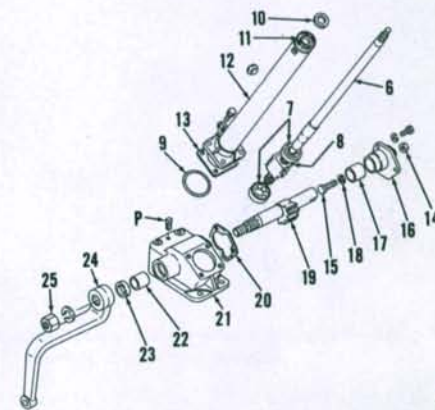
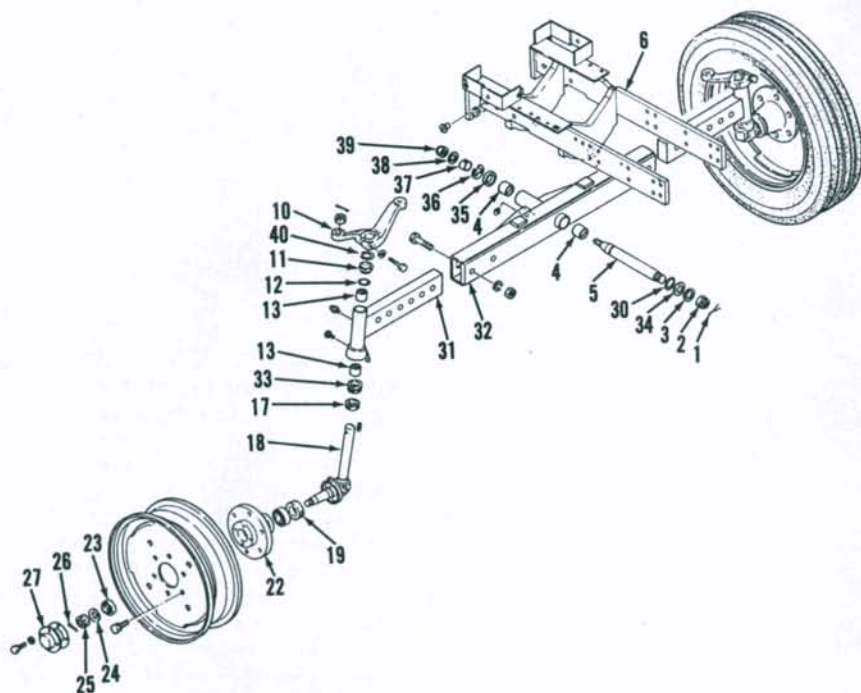

Fig. 6 - Exploded view of steering gear typical of type used on YM195, YM195D, YM240, YM240D, YM330 and YM330D models. Refer to Fig. 5 for legend.

- |                  |                            |                        |
|------------------|----------------------------|------------------------|
| 1. Cotter pin    | 18. Spindle                | 31. Axle extension     |
| 2. Castle nut    | 19. Seal                   | 32. Axle center member |
| 3. Washer        | 21. Roller bearing (32007) | 33. Thrust bearing     |
| 4. Bushings      | 22. Hub                    | 34. Plain washer       |
| 5. Pivot pin     | 23. Roller bearing (30205) | 35. Seal               |
| 6. Frame         | 24. Plain washer           | 36. Snap ring          |
| 10. Steering arm | 25. Castle nut             | 37. Taper sleeve       |
| 11. Cover        | 26. Cotter pin             | 38. Washer             |
| 12. "O" ring     | 27. Cap                    | 39. Nut                |
| 13. Bushings     | 30. Shims                  | 40. Shims              |
| 17. Seal         |                            |                        |

Fig. 3 - Exploded view of adjustable axle used on YM330 models.





# FRONT WHEEL DRIVE

## OUTER DRIVE HOUSING

### YM135D and YM155D Models

**15. R&R AND OVERHAUL.** The complete outer drive housing can be separated from axle after removing fasteners (A—Fig. 15) or disassembly can be accomplished before detaching outer end of axle from center section.

To remove the complete outer drive housing, remove wheel, detach drag link and/or tie rod from steering arm and support axle from tipping. Support outer drive housing separately, then remove the two screws and two nuts (A). Move outer drive housing away from axle center section. Disassembly of outer drive assembly can be accomplished as outlined in the following paragraphs.

Some disassembly can be accomplished with outer drive housing attached to axle center section. If attached, remove wheel and support axle from tipping. Remove the four screws (C—Fig. 16), then withdraw the axle (1) and cover (4) from gear housing (15). Be sure to save shims (7) located between cover and housing.

Inner bearing (8), spacer (9) and snap ring (5) must be removed before withdrawing outer bearing (8) and seal (6) from around axle (1). Seal wear sleeve (3) can remain on axle unless new sleeve is to be installed.

Support outer drive housing and remove nut (B), washers, shims (34) and steering arm (35). Unbolt spindle housing (25) from gear housing (15) and separate the two housings. Gear (18) and bearings (24 and 28) can be removed, cleaned and inspected. Bearings (19) and spacer (21) can be pressed from housing (25) if removal is required.

When assembling, upper bearing (19) is sealed on one side and is identified by "6305U" marked on side of bearing. The one sealed side should be down, away from seal (27), for the uppermost bearing (19). The lower bearing marked "6305", not sealed and should be installed in lower bearing bore. Spring loaded lip of seal (27) should be down toward bearing; spring loaded lip of seal (17) should be up. Inside diameter of one race for thrust bearings (28) is 25 mm, the other race inside diameter is 25.2 mm. Install thrust bearings with large I.D. inner races toward gear (18). Remainder of assembly is reverse of disassembly; however, shims should be used to adjust backlash between gears. Vary the thickness of shims and washer at (39) to obtain 0.1-0.3 mm (0.0039-0.0118 in.) backlash between

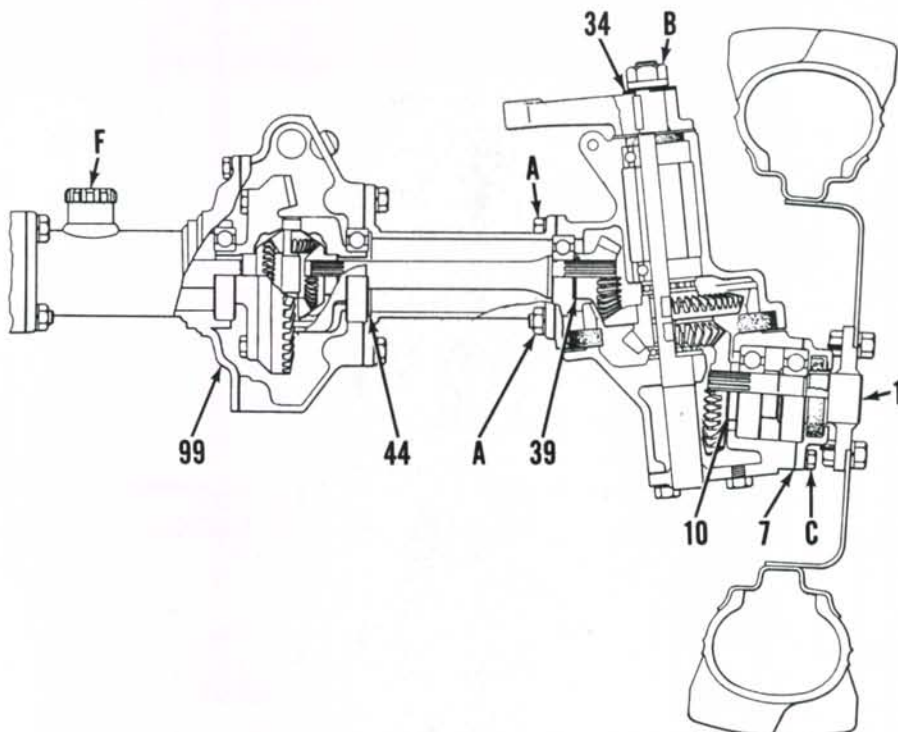

Fig. 15—Cross-section of front drive axle used on late YM135D and YM155D models. Early models are similar. Refer to Fig. 17 for legend.

gears (18 and 36). Vary thickness of shims at (10) to obtain 0.1-0.3 mm (0.0039-0.0118 in.) backlash between gears (11 and 18). Shims (34) should be installed between washers (29) as necessary to limit the clearance between bottom of flat washer and the top of upper washer (29) to less than 0.1 mm

(0.0039 in.). Do not reduce clearance to less than zero which would cause the steering to bind. Turn stop screw (S) as required so that rear surface of head is 11 mm from rear surface of flange, then tighten locknut against front surface.

Screws and nuts (A) should be tightened to 45-58 N·m (33.19-42.78 ft.-lbs.)

Fig. 16—Exploded view of outer drive housing used on late YM135D and YM155D models. Early models are similar. Inner bearing (8) is 6305 on early models. Refer to Fig. 17 for legend.

