YANMAR

SERVICE MANUAL



ISO 9001 *Certified*

DIESEL OUTBOARD MOTOR

FOREWORD

This service manual outlines procedures for servicing and maintaining YANMAR D27A/ D36A DIESEL OUTBOARD MOTOR to obtain maximum life and performance.

It explains about the structure, performance, disassembly and reassembly procedures, important inspection points, servicing instructions and the wear limit of parts. For full understanding of this manual, also refer to the Operation Manual and Parts Catalog. Besides reference use at your service shop, this manual can also be used as a text for your service engineers.

A full understanding of the content of this manual leads to accurate and efficient services. Good servicing guarantees the machine's performance and prevents troubles.

Please note that there may be changes in the structure explanations or maintenance instructions resulting from future improvements in quality and performance. If you have any questions, please contact us.

For accurate and efficient work, the following preparations are necessary:

1. Check the customer's service chart
 - 1) When was the last service?
 - 2) How many months or hours has the machine been used since the last service?
 - 3) What was the trouble and what parts were replaced in the last service?
 - 4) What parts must be replaced in the present service?
2. Preparation of parts
Check the inventory of parts that are necessary for servicing.
3. Preparation of report forms
Inspection and service check sheets, parts measurement record forms and operation test record forms.
4. Prepare the servicing tools, measuring instruments and containers, etc.



ISO 9001 Certified

This product has been developed, designed and manufactured in accordance with the Standards for Quality System of ISO 9001 (International Organization for Standardization) under the following authorized institutions: JMI (Japan Machinery and Metals Inspection) Institute, BSI (British Standards Institution) and EQNET (The European Network for Quality System Assessment and Certification).

Certified under the following standards:
ISO 9001 - 1987 / BS 5750 : Part 1 : 1987 /
EN 29001 - 1987 / JIS Z9901 - 1991

MODEL **D27A & D36A**

CHAPTER 1 GENERAL

- 1. Specifications 1-1
- 2. Exterior View 1-3
- 3. Cross-sectional View 1-10

CHAPTER 2 DISASSEMBLY AND REASSEMBLY

- 1. Preparations Before Disassembly and Reassembly 2-1
- 2. Tools, Measuring Instruments and Service Equipment 2-2
- 3. Exploded View of Parts 2-12
- 4. Reassembly Procedures 2-14
- 5. Reassembly Procedures for Drive Unit 2-29

CHAPTER 3 INSPECTION AND SERVICE PROCEDURES FOR ENGINE PARTS

- 1. Inspection and Service Procedures for Engine Parts 3-1
- 2. Cylinder Block 3-2
- 3. Piston and Connecting Rod 3-4
- 4. Crankshaft 3-7
- 5. Camshaft 3-8
- 6. Cylinder Head 3-9
- 7. Valve Arm Case 3-13
- 8. Intake/Exhaust Valve Arm and Unit Injector 3-14
- 9. Thermostat 3-17
- 10. Unit Injector 3-18
- 11. Governor 3-24

CHAPTER 4 REASSEMBLING AND SERVICING OF DRIVE UNIT

- 1. Swivel/Steering Bracket 4-1
- 2. Clamp Bracket 4-4
- 3. Upper Case 4-5
- 4. Bottom Cowling and Fitting Parts 4-6
- 5. Lower Gear Case 4-9
- 6. Cooling Water Pump and Cooling Water Piping 4-15
- 7. Steering Handle 4-16
- 8. Hydraulic Cylinder 4-17
- 9. Electric-Hydraulic Tilting 4-18
- 10. Connecting the Upper Case with Steering Bracket 4-20

CHAPTER 5 PIPING DIAGRAM

- 1. Piping Diagram 5-1

CHAPTER 6 ELECTRIC EQUIPMENT

- 1. Generator 6-1
- 2. Starting Motor (Reduction Gear) 6-2
- 3. Warning Device 6-4
- 4. Wiring Diagram 6-6

CHAPTER 7 SERVICE STANDARD

- 1. Service Standard Table (Engine) 7-1
- 2. Service Standard Table (Drive Unit) 7-3

CHAPTER 8 MAIN BOLT TIGHTENING TORQUE

- 1. Main Bolt Tightening Torque 8-1

CHAPTER 9 BACKLASH ADJUSTMENT

- 1. Backlash Adjustment 9-1

CHAPTER 10 PERIODICAL INSPECTION

- 1. Periodical Inspection Table 10-1

CHAPTER 11 OPTION

- 1. Diesel Outboard Propeller Guard Holes 11-1

CHAPTER 1
GENERAL

1. Specifications	1-1
2. Exterior View	1-3
3. Cross-sectional View	1-10

1. Specifications

1-1 D27A and D36A series

Model		D27A				D36A				
		XE	XEP	YE	Y	XE	XEP	YE	YEP	
Main item	Overall length (mm)	730		1128 (When folding the handle 730)		759		1157 (When folding the handle 759)		
	Overall width (mm)	392		430		437		449		
	Overall height (mm)	L	1380	←	1434	1417	1438	←	←	←
		LL	1443	←	1493	1480	1501	←	←	←
		UL	1505	←	1559	1542	1563	←	←	←
		SUL	1710	←	1639	1622	—	—	—	—
	Transom length (mm)	L	560	←	←	←	←	←	←	←
		LL	623	←	←	←	←	←	←	←
		UL	685	←	←	←	←	←	←	←
		SUL	765	←	←	←	←	←	←	←
*1) Weight (kg)	L	94	102	95	92	116	120	116	120	
	LL	95	103	96	93	117	121	117	121	
	UL	96	104	97	94	118	122	118	122	
	SUL	97	105	98	95	—	—	—	—	
Tilt system	Manual	Hydraulic	Manual	Manual	Manual	Hydraulic	Manual	Hydraulic		
Starting system	Electric	Electric	Electric	Recoil	Electric	Electric	Electric	Electric		
Steering system	Remote control	Remote control	Bar handle	Bar handle	Remote control	Remote control	Bar handle	Bar handle		
Max. Output	19.9KW (27HP) / 4500rpm				26.5KW (36HP) / 4500rpm					
Type	4 cycle water cooled, Vertical Crankshaft Diesel Engine									
No. of cylinders	3									
Bore × Stroke (mm)	70 × 70				82 × 70					
Displacement (ℓ)	808				1109					
Combustion system	Direct injection by M-type unit injector									
Brake mean effective pressure	0.70MPa (7.18kgf/cm ²)				0.68MPa (6.98kgf/cm ²)					
Mean piston speed	10.5m/s									
Max. combustion pressure / compression ratio	≤ 9.8MPa (100kgf/cm ²) / 19.2									
Piston head clearance / valve clearance	0.60±0.05mm/0.2mm				0.55±0.05mm/0.2mm					
Fuel injection timing	FIC 12° b.T.D.C				FIC 15° b.T.D.C					
Fuel injection nozzle	YDLLA-P-type hole nozzle 4-φ0.2mm				YDLLA-P-type hole nozzle 5-φ0.22mm					
Fuel injection valve opening pressure	19.61±0.49 MPa(200±5 kgf/cm ²)									
Firing order	1-240°-2-240°-3-240°-1									
Direction of revolution	Clockwise (viewed from flywheel side)									
Power take-off direction	Counter-flywheel side									
Driving system of intake / exhaust valve and fuel pump	O.H.C. system driven by timing belt									
Intake system	Intake inertia flow pipe									
Exhaust system	Cooling water mixing and underwater exhaust system									
Lubricating system	Forced lubrication by trochoid pump									
Lube oil sump capacity	Full amount	2.4 ℓ				3.0 ℓ				
	Effective amount	1.0 ℓ				1.3 ℓ				
Type of lube oil	API service grade CD class SAE 15W-40									

Model		D27A				D36A			
		XE	XEP	YE	Y	XE	XEP	YE	YEP
Engine	Cooling system	Direct seawater cooling by rubber impeller pump							
	Fuel feed system	Pressure-feeding by trochoid pump							
	Governor type	Mechanical floating lever type							
	Starter capacity	12V - 1.2KW			—	12V - 1.4KW			
	Generator type / capacity	Dynamo house in flywheel / 12V - 10A							
	Battery capacity	12V-100A			—	12V - 100AH or more			
Fuel equipment	Fuel tank type/capacity	Portable / 24 ℓ							
	Fuel pipe	Returned to tank when overflowing, with primary valve, with one-touch joint on the fuel tank side							
Steering equipment	Steering angle	Max. 40 degrees right-to-left							
	Speed control system and angle	Remote control system		Bar handle grip revolving system 85°		Remote control system		Bar handle grip revolving system 85°	
	Tilting step and angle	4 steps 7°-23°	Power tilt (Arbitrary)	4 steps 7°-23°	5 steps 8°-24°	Power tilt (Arbitrary)	5 steps 8°-24°	Power tilt (Arbitrary)	
	Max. tilting up angle	76°	76°	76°	76°	76°	76°	76°	
	Angle when running in shallow sea	32° (″)	Less than 2000 rpm	32° (When tilting angle is 7°)	32° (″)	Less than 2000 rpm	32° (″)	Less than 2000 rpm	
	Hull mounting	Bolted to transom plate							
Driving equipment	Clutch type and operation	Dog type, clutch lever operation							
	Reduction gear type	Bevel gear							
	Reduction ratio (forward / reverse)	1.846 / 1.846							
	Lubrication system	Oil bath							
	Lube oil capacity	0.55 ℓ							
	Type of oil	Gear oil API service grade SAE 80W-90							
Propeller	Driving (damping) system	Spline and rubber press-fitting type							
	Direction of rotation	Clockwise (viewed from propeller side)							
	Max. rpm (forward / reverse)	2438 rpm / 1356-1625rpm							
	Number of blades-diameter × pitch	3-266.7 × 203 ~ 3-266.7 × 330 (11 types)				3-292.1 × 228.6 ~ 3-292.1 × 381 (10 types)			

*1) Dry weight of outboard motor

2. Exterior View

2-1 D27A series

(1) D27AX

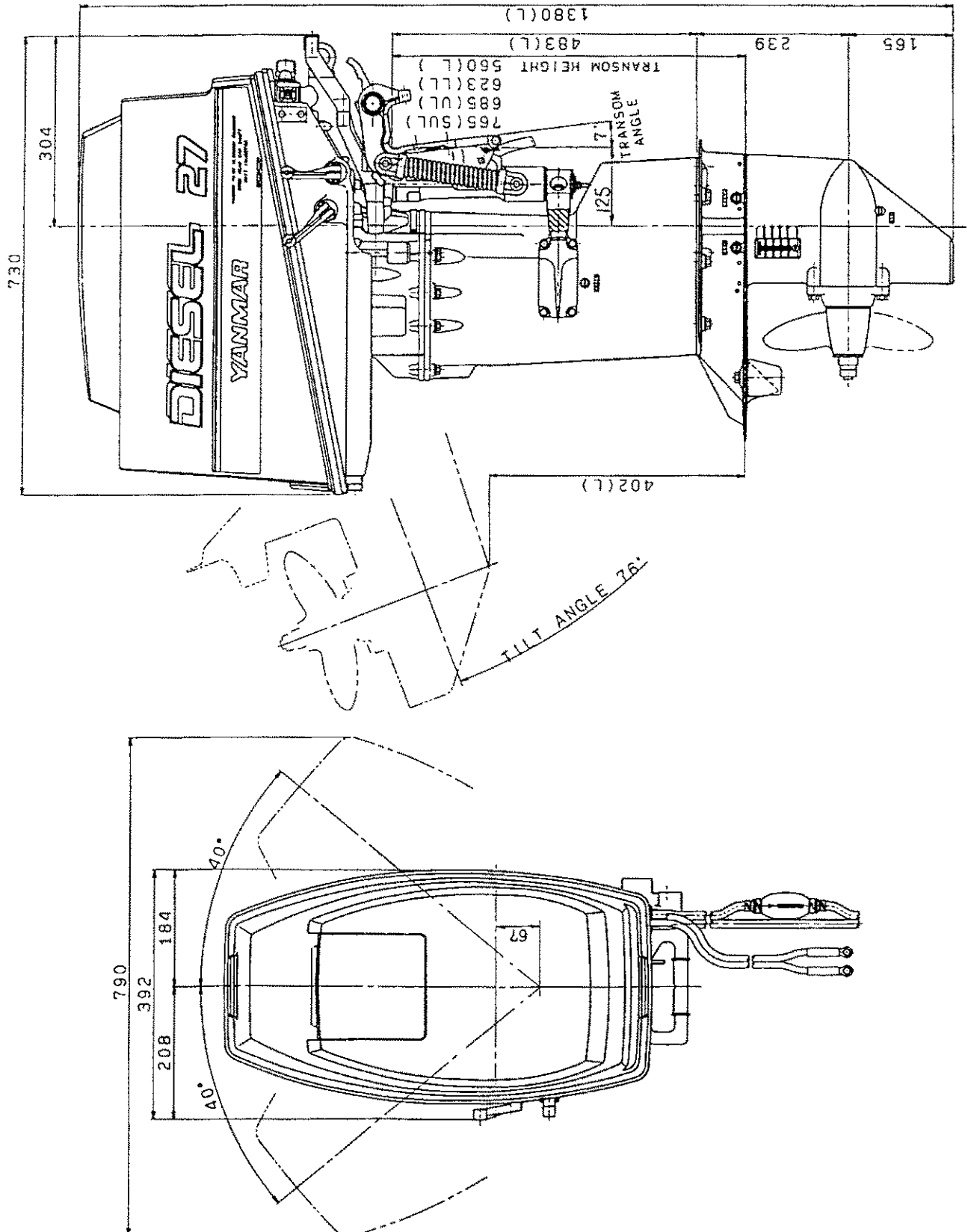

(2) D27AXEP

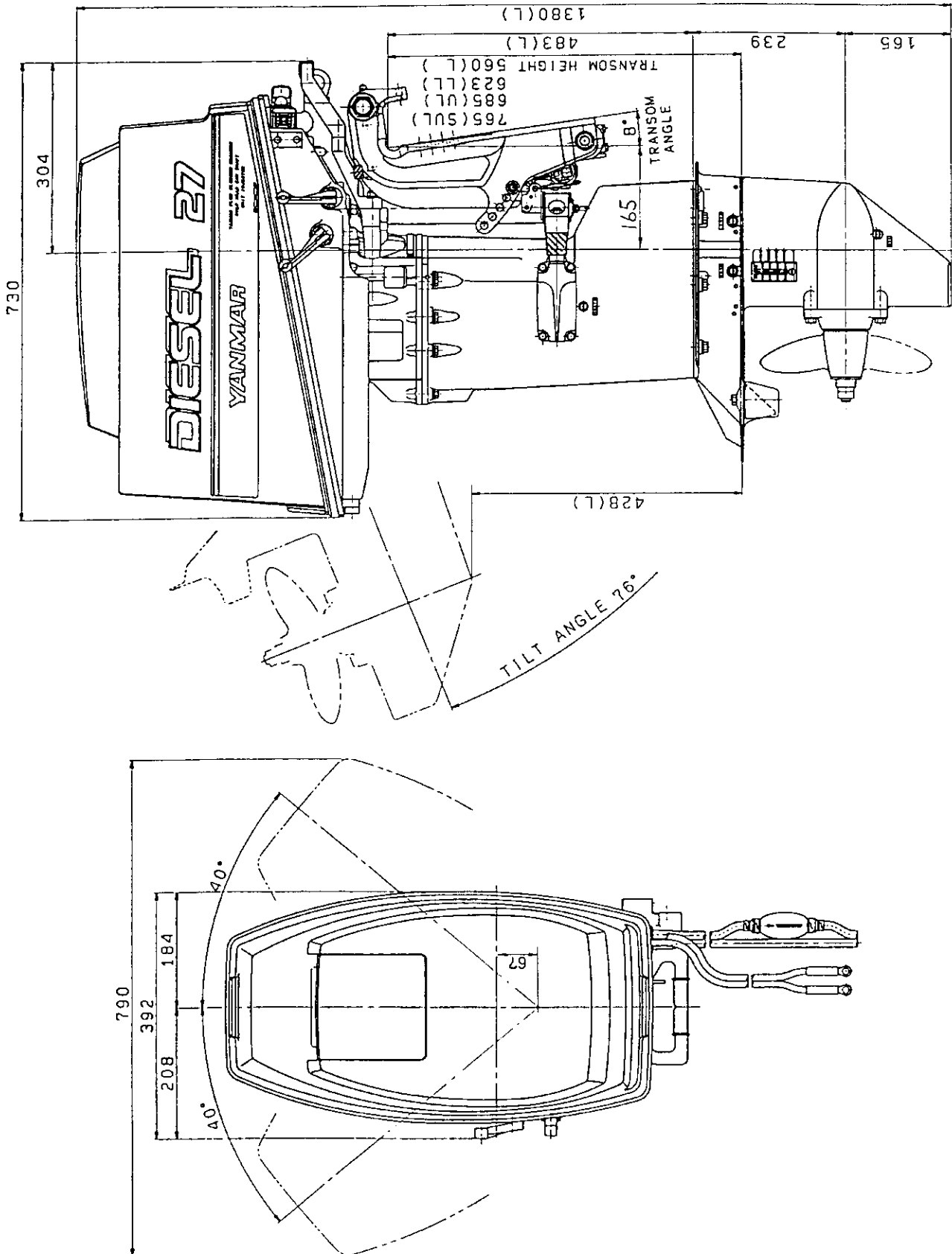

(3) D27AYE

