

YANMAR®

SERVICE MANUAL

L40-L100 AIR COOLED LA SERIES

INDUSTRIAL DIESEL ENGINES

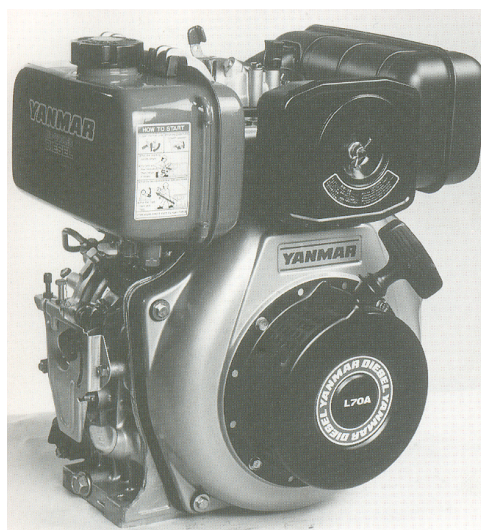

INTRODUCTION

This Service Manual offers instructions on standard service procedures (disassembly and reassembly) for Yanmar Diesel Engine models L40AE, L48AE, L60AE, L70AE, L75AE, L90AE and L100AE. More detailed information is given particularly in the sections of the construction and function of each engine part.

Before servicing these engines, make sure you read this manual carefully.

The information contained in this manual will be updated periodically to incorporate improvements in the quality and performance of our engines.

Before beginning your service work:

To insure efficient service and repairs, the following pre-service steps should be taken:

1. Check your customer control book

- (1) When was the engine last serviced?
- (2) What is the engine's service history?
 - a. How often was the engine serviced (after how many months or hours of operation)?
 - b. What problems has the engine had in the past?

2. Stock control (spare parts)

- (1) Keep a good stock of engine parts and other items necessary for efficient servicing.
- (2) Keep a copy of the check/service parts list and plenty of parts cards on hand.

3. Keep an accurate service record (diary, notes, etc.)

- (1) Work (manpower) table
 - (2) Check list (including service parts list)
 - (3) Parts measurement data
 - (4) Operation data
- } Maintenance of performance and quality

4. Tools and equipment required for service

- (1) Tools
- (2) Meters and instruments
- (3) Others

Service Information

1. GENERAL SAFETY

WARNING

STOP THE ENGINE BEFORE SERVICING

1) PREVENTING FIRES

- Never add fuel to the fuel tank while the engine is running. Wipe away all fuel spills with a clean cloth.
- Keep gasoline, kerosene, matches, other explosives and inflammables away from the engine, since the temperature around the exhaust silencer is very high during operation.
- To prevent fire hazards and to provide adequate ventilation, keep the engine at least 3 ft (1m) away from the building and other equipment during operation.

2) PREVENTING EXHAUST GAS INHALATION

- Note that exhaust gas contains carbon monoxide (CO), nitrogen oxide (NOx), hydrocarbon (HC), sulfur oxide (SOx), and particulates.
- Never use the engine in poorly ventilated locations such as indoors, inside of tunnels and so on. If indoor operation is unavoidable, provide proper ventilation so that people and cattle will not be affected.

3) PREVENTING BURNS

- Never touch the exhaust silencer, muffler cover or engine body while the engine is running or hot.

4) PRECAUTIONS FOR THE BATTERY

- The battery electrode is essentially dilute sulfuric acid, which injures the human body and damages clothes. Should it touch the body or clothes, immediately wash it away. If it enters your eye, hasten to consult the doctor.
- Never use fire near the battery during charging, which generates hydrogen.
- Charge the battery in a well ventilated place.

5) OTHERS

- Wear safety shoes, working clothes, etc. before servicing the engine.
- Do not service the engine under the influence of alcohol.
- Keep children and pets away from the engine in operation.
- Do not have access to rotary part during operation, which is extremely dangerous.

2. SERIAL NUMBER LOCATION

Engine serial number (E/#) is indicated in the engine nameplate, and is stamped on the crankcase cover. Before ordering service parts, be sure to check serial number and identify necessary parts by nos. (Parts may not have interchangeability as a result of a change in the specification.)

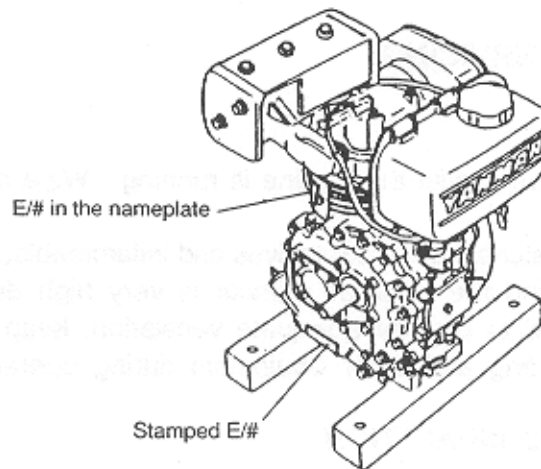

3. SERVICE RULES

1. Use genuine YANMAR parts. Parts that do not meet YANMAR's design specification may damage the engine.
2. In disassembling the engine in trouble, exactly locate the cause of trouble. Remove or disassemble only the parts specified in the troubleshooting procedure.
3. Use the special tools designed for this engine.
4. Install new gasket, O-ring, cotter pins, etc. when reassembling.
5. When torquing bolts or nuts, tighten them to the specified torque diagonally.
6. Clean parts in cleaning solvent upon disassembly. Lubricate any sliding surfaces before reassembly.
7. After reassembly, check all parts for proper installation and operation.

CONTENTS

1. Specifications	1
1.1 Specifications	1
1.2 Cross Sectional Views	5
2. Service standard	8
3. Disassembly and Reassembly	18
3.1 Tools, Meters and Instruments	18
1. Tools	18
2. Meters, Instruments and Service Accessories	20
3. Instruments	22
3.2 Tightening Torque	23
3.3 Maintenance Schedule	24
3.4 Disassembly Procedures	25
3.5 Reassembly Procedures	29
3.6 Recoil Starter	34
4. Checking and Servicing	37
4.1 Cylinder Head	37
4.2 Piston and Piston Pin	41
4.3 Connecting Rod	45
4.4 Crankshaft, Flywheel and Main Bearing	49
4.5 Camshaft and Tappet	51
4.6 Timing Gear	52
4.7 Crankcase Cover	53
4.8 Cylinder Sleeve and Cylinder Block	55
4.9 Lubrication System	56
4.10 Fuel System	58
4.11 Speed Control Device	62
4.12 Electrical System	64
1. Wiring Diagram	64
2. Starter Motor	69
3. Generator (Dynamo), Regulator and Rectifier	84
4. Air Heater	89
5. Battery	90
4.13 Adjustment	93
5. Troubleshooting	95
6. Test Run	111
7. Helical Inserting Part for Repair	114
Appendix 1 Difference Between Parts under Spec. S and D	117
Appendix 2 Detail of Special Tools	120

Specifications

1. Specifications

1.1 Specifications

Item	Model	L40AE –				L48AE –			
		D	S	DE	SE	D	S	DE	SE
Type		Single-cylinder, vertical-4 cycle air-cooled diesel							
Cooling system		Forced air cooling by flywheel fan							
Combustion system		Direct injection system							
Starting system		Recoil starter		Starting motor with recoil starter		Recoil starter		Starting motor with recoil starter	
Number of cylinders - Bore × Stroke	mm (in.)	1-68 × 55 (2.677 × 2.165)				1-70 × 55 (2.756 × 2.165)			
Displacement	ℓ (cu.in.)	0.199 (12.14)				0.211 (12.88)			
Output	Continuous	2.8 (3.8)				3.1 (4.2)			
	Maximum	3.1 (4.2)				3.5 (4.7)			
Speed (PTO shaft)	rpm	3600	1800	3600	1800	3600	1800	3600	1800
Speed at no-load, max/min	rpm	3800 ⁺³⁰ / ₁₂₀₀	1900 ⁺¹⁵ / ₆₀₀	3800 ⁺³⁰ / ₁₂₀₀	1900 ⁺¹⁵ / ₆₀₀	3800 ⁺³⁰ / ₁₂₀₀	1900 ⁺¹⁵ / ₆₀₀	3800 ⁺³⁰ / ₁₂₀₀	1900 ⁺¹⁵ / ₆₀₀
Compression ratio		20.0				19.9			
PTO shaft	PTO position	Crank	Cam	Crank	Cam	Crank	Cam	Crank	Cam
	Direction of revolution	Counterclockwise viewed from PTO shaft							
Fuel oil	Fuel injection pump	Bosch type, YANMAR PFE-M type							
	Fuel injection timing (FID)	bTDC 14 ^{±1}							
	Fuel injection nozzle	Hole nozzle, YANMAR YDLLA-P type							
	Fuel injection pressure	Mpa (kgf/cm ²) 19.6 (200)							
	Fuel oil selection	Diesel fuel BS 2869 A1 or equivalent							
	Fuel oil filter	Paper element, FO tank built-in type							
	Fuel oil tank capacity	ℓ(US gal.)	2.5 (0.66)						
Lubricating oil	Type of lubrication	Forced lubrication via trochoid pump; splash lubrication for valve rocker arm chamber							
	Lubricating oil filter	Resin, 60 mesh							
	Lubricating oil selection	SAE 10W30, API grade CC or higher							
	Lubricating oil capacity	ℓ(US gal.)	0.80 (0.21) effective 0.25 (0.07)						
Air cleaner		Wet type paper element filter (Oil-bath type: Option)							
Exhaust silencer		Expansion silencer with cover							
Governor		All speed type, mechanical							
Engine dimensions (Length × Width × Height)	mm (in.)	D-spec. 332 × 384 × 416 (13.071 × 15.118 × 16.378) S-spec. 324 × 384 × 416 (12.756 × 15.118 × 16.378)							
Dry weight	kg (lb)	25.5 (56.2)		31.0 (68.3)		25.5 (56.2)		31.0 (68.3)	
Permissible angle of inclination	deg.	20 (momentary 30)							
Balancer shaft		Single shaft							

Specifications

Item		Model	L60AE				L70AE			
			D	S	DE	SE	D	S	DE	SE
Type			Single-cylinder, vertical-4 cycle air-cooled diesel							
Cooling system			Forced air cooling by flywheel fan							
Combustion system			Direct injection system							
Starting system			Recoil starter		Starting motor with recoil starter		Recoil starter		Starting motor with recoil starter	
Number of cylinders - Bore × Stroke		mm (in.)	1-75 × 62 (2.953 × 2.441)				1-78 × 62 (3.071 × 2.441)			
Displacement		ℓ (cu.in.)	0.273 (16.66)				0.296 (18.06)			
Output	Continuous	kW (HP)	4.0 (5.5)				4.4 (6.0)			
	Maximum		4.4 (6.0)				4.9 (6.7)			
Speed (PTO shaft)		rpm	3600	1800	3600	1800	3600	1800	3600	1800
Speed at no-load, max/min		rpm	3800 ^{±30} 1200	1900 ^{±15} 600	3800 ^{±30} 1200	1900 ^{±15} 600	3800 ^{±30} 1200	1900 ^{±15} 600	3800 ^{±30} 1200	1900 ^{±15} 600
Compression ratio			19.5							
PTO shaft	PTO position		Crank	Cam	Crank	Cam	Crank	Cam	Crank	Cam
	Direction of revolution		Counterclockwise viewed from PTO shaft							
Fuel oil	Fuel injection pump		Bosch type, YANMAR PFE-M type							
	Fuel injection timing (FID)	bTDC	14 ^{±1}							
	Fuel injection nozzle		Hole nozzle, YANMAR YDLLA-P type							
	Fuel injection pressure	Mpa (kg/cm ²)	19.6 (200)							
	Fuel oil selection		Diesel fuel BS 2869 A1 or equivalent							
	Fuel oil filter		Paper element, FO tank built-in type							
Fuel oil tank capacity		ℓ (US gal.)	3.5 (0.92)							
Lubricating oil	Type of lubrication		Forced lubrication via trochoid pump; splash lubrication for valve rocker arm chamber							
	Lubricating oil filter		Resin, 60 mesh							
	Lubricating oil selection		SAE 10W30, API grade CC or higher							
	Lubricating oil capacity	ℓ (US gal.)	1.1 (0.29) effective 0.4 (0.11)							
Air cleaner			Wet type paper element filter (Oil-bath type: Option)							
Exhaust silencer			Expansion silencer with cover							
Governor			All speed type, mechanical							
Engine dimensions (Length × Width × Height)		mm (in.)	D-spec. 383 × 421 × 450 (15.079 × 16.575 × 17.717) S-spec. 358 × 421 × 450 (14.094 × 16.575 × 17.717)							
Dry weight		kg (lb)	33.5 (73.9)		39.0 (86.0)		33.5 (73.9)		39.0 (86.0)	
Permissible angle of inclination		deg.	20 (momentary 30)							
Balancer shaft			Single shaft							

Specifications

Item		Model	L75AE-				L90AE-			
			D	S	DE	SE	D	S	DE	SE
Type			Single-cylinder, vertical-4 cycle air-cooled diesel							
Cooling system			Forced air cooling by flywheel fan							
Combustion system			Direct injection system							
Starting system			Recoil starter		Starting motor with recoil starter		Recoil starter		Starting motor with recoil starter	
Number of cylinders - Bore × Stroke		mm (in.)	1-80 × 70 (3.150 × 2.756)				1-84 × 70 (3.307 × 2.756)			
Displacement		ℓ (cu.in.)	0.351 (21.42)				0.387 (23.62)			
Output	Continuous	kW (HP)	4.8 (6.5)				5.9 (8.0)			
	Maximum		5.5 (7.5)				6.6 (9.0)			
Speed (PTO shaft)		rpm	3600	1800	3600	1800	3600	1800	3600	1800
Speed at no-load, max/min		rpm	$\frac{3800^{+30}}{1200}$	$\frac{1900^{+15}}{600}$	$\frac{3800^{+30}}{1200}$	$\frac{1900^{+15}}{600}$	$\frac{3800^{+30}}{1200}$	$\frac{1900^{+15}}{600}$	$\frac{3800^{+30}}{1200}$	$\frac{1900^{+15}}{600}$
Compression ratio			20.2				18.9			
PTO shaft	PTO position		Crank	Cam	Crank	Cam	Crank	Cam	Crank	Cam
	Direction of revolution		Counterclockwise viewed from PTO shaft							
Fuel oil	Fuel injection pump		Bosch type, YANMAR PFE-M type							
	Fuel injection timing (FID)	bTDC	13°							
	Fuel injection nozzle		Hole nozzle, YANMAR YDLLA-P type							
	Fuel injection pressure	Mpa (kg/cm ²)	19.6 (200)							
	Fuel oil selection		Diesel fuel BS 2869 A1 or equivalent							
	Fuel oil filter		Paper element, FO tank built-in type							
	Fuel oil tank capacity	ℓ (US gal.)	5.5 (1.45)							
Lubricating oil	Type of lubrication		Forced lubrication via trochoid pump; splash lubrication for valve rocker arm chamber							
	Lubricating oil filter		Resin, 60 mesh							
	Lubricating oil selection		SAE 10W30, API grade CC or higher							
	Lubricating oil capacity	ℓ (US gal.)	1.65 (0.44) effective 0.6 (0.16)							
Air cleaner			Wet type paper element filter (Oil-bath type: Option)							
Exhaust silencer			Expansion silencer with cover							
Governor			All speed type, mechanical							
Engine dimensions (Length × Width × Height)		mm (in.)	D-spec. 417 × 470 × 494 (16.417 × 18.503 × 19.449) S-spec. 392 × 470 × 494 (15.433 × 18.503 × 19.449)							
Dry weight		kg (lb)	48.5 (106.9)		54.0 (119.0)		48.5 (106.9)		54.0 (119.0)	
Permissible angle of inclination		deg.	20 (momentary 30)							
Balancer shaft			Single shaft							

Specifications

Item		Model	L100AE-			
			D	S	DE	SE
Type			Single-cylinder, vertical-4 cycle air-cooled diesel			
Cooling system			Forced air cooling by flywheel fan			
Combustion system			Direct injection system			
Starting system			Recoil starter		Starting motor with recoil starter	
Number of cylinders - Bore × Stroke		mm (in.)	1-86 × 70 (3.386 × 2.756)			
Displacement		ℓ (cu.in.)	0.406 (24.78)			
Output	Continuous	kW (HP)	6.6 (9.0)			
	Maximum		7.4 (10.0)			
Speed (PTO shaft)		rpm	3600	1800	3600	1800
Speed at no-load, max/min		rpm	3800 ^{±30} /1200	1900 ^{±15} /600	3800 ^{±30} /1200	1900 ^{±15} /600
Compression ratio			19.3			
PTO shaft	PTO position		Crank	Cam	Crank	Cam
	Direction of revolution		Counterclockwise viewed from PTO shaft			
Fuel oil	Fuel injection pump		Bosch type, YANMAR PFE-M type			
	Fuel injection timing (FID)	bTDC	13 ^{±1}			
	Fuel injection nozzle		Hole nozzle, YANMAR YDLLA-P type			
	Fuel injection pressure	Mpa (kgf/cm ²)	19.6 (200)			
	Fuel oil selection		Diesel fuel BS 2869 A1 or equivalent			
	Fuel oil filter		Paper element, FO tank built-in type			
	Fuel oil tank capacity	ℓ (US gal.)	5.5 (1.45)			
Lubricating oil	Type of lubrication		Forced lubrication via trochoid pump; splash lubrication for valve rocker arm chamber			
	Lubricating oil filter		Resin, 60 mesh			
	Lubricating oil selection		SAE 10W30, API grade CC or higher			
	Lubricating oil capacity	ℓ (US gal.)	1.65 (0.44) effective 0.6 (0.16)			
Air cleaner			Wet type paper element filter (Oil-bath type: Option)			
Exhaust silencer			Expansion silencer with cover			
Governor			All speed type, mechanical			
Engine dimensions (Length × Width × Height)		mm (in.)	D-spec. 417 × 470 × 494 (16.417 × 18.504 × 19.449) S-spec. 392 × 470 × 494 (15.433 × 18.503 × 19.449)			
Dry weight		kg (lb)	48.5 (106.9)		54.0 (119.0)	
Permissible angle of inclination		deg.	20 (momentary 30)			
Balancer shaft			Single shaft			

Specifications

1.2 Cross Sectional Views

