



XVS650

Service Manual

LIT-11616-XV-00

YAMAHA

XVS650AK(C)

SERVICE MANUAL

**XVS650AK(C)
SERVICE MANUAL**

©1997 by Yamaha Motor Corporation, U.S.A.

First edition, August 1997

**All rights reserved. Any reproduction or
unauthorized use without the written
permission of Yamaha Motor Corporation, U.S.A.
is expressly prohibited.**

Printed in U.S.A.

LIT-11616-11-16

NOTICE

This manual was produced by the Yamaha Motor Company primarily for use by Yamaha dealers and their qualified mechanics. It is not possible to include all the knowledge of a mechanic in one manual, so it is assumed that anyone who uses this book to perform maintenance and repairs on Yamaha motorcycles has a basic understanding of the mechanical ideas and the procedures of motorcycle repair. Repairs attempted by anyone without this knowledge are likely to render the motorcycle unsafe and unfit for use.

Yamaha Motor Company, Ltd. is continually striving to improve all its models. Modifications and significant changes in specifications or procedures will be forwarded to all authorized Yamaha dealers and will appear in future editions of this manual where applicable.

NOTE: _____
Designs and specifications are subject to change without notice.

IMPORTANT INFORMATION

Particularly important information is distinguished in this manual by the following notations.



The Safety Alert Symbol means ATTENTION! BECOME ALERT! YOUR SAFETY IS INVOLVED!

WARNING

Failure to follow WARNING instructions could result in severe injury or death to the motorcycle operator, a bystander or a person inspecting or repairing the motorcycle.

CAUTION

A CAUTION indicates special precautions that must be taken to avoid damage to the motorcycle.

NOTE: A NOTE provides key information to make procedures easier or clearer.

HOW TO USE THIS MANUAL

MANUAL ORGANIZATION

This manual consists of chapters for the main categories of subjects. (See "Illustrated symbols")

1st title ①: This is the title of the chapter with its symbol in the upper right corner of each page.

2nd title ②: This title indicates the section of the chapter and only appears on the first page of each section. It is located in the upper left corner of the page.

3rd title ③: This title indicates a sub-section that is followed by step-by-step procedures accompanied by corresponding illustrations.

EXPLODED DIAGRAMS

To help identify parts and clarify procedure steps, there are exploded diagrams at the start of each removal and disassembly section.

1. An easy-to-see exploded diagram ④ is provided for removal and disassembly jobs.
2. Numbers ⑤ are given in the order of the jobs in the exploded diagram. A number that is enclosed by a circle indicates a disassembly step.
3. An explanation of jobs and notes is presented in an easy-to-read way by the use of symbol marks ⑥. The meanings of the symbol marks are given on the next page.
4. A job instruction chart ⑦ accompanies the exploded diagram, providing the order of jobs, names of parts, notes in jobs, etc.
5. For jobs requiring more information, the step-by-step format supplements ⑧ are given in addition to the exploded diagram and the job instruction chart.

②
①
⑥

CLUTCH
CLUTCH COVER

④

⑤

Order	Job name/Part name	Qty	Remarks
	Clutch cover removal		Remove the parts in the order below. Stand the motorcycle on a level surface. WARNING Securely support the motorcycle so there is no danger of it falling over.
	Engine oil		Refer to "ENGINE OIL REPLACEMENT" in CHAPTER 3.
	Muffler assembly 1,2		Refer to "ENGINE REMOVAL".
	Brake pedal link		
1	Oil filter cover plate	1	
2	Oil filter cover	1	L=70 mm x 1, 65 mm x 1, 25 mm x 3
3	O-ring	1	
4	Oil filter	1	
5	Crankcase cover (right)	1	L=65 mm x 1, 55 mm x 1, 45 mm x 4, 30 mm x 4

⑦

CLUTCH REMOVAL

1. Straighten:
• Lock washer tab
2. Loosen:
• Nut (clutch boss) ①

NOTE:
Loosen the nut (clutch boss) ① while holding the clutch boss ② with the clutch holding tool ③.

Clutch holding tool:
Semi-cass

PRIMARY DRIVE GEAR REMOVAL

1. Straighten:
• Lock washer tab
2. Loosen:
• Nut (primary drive gear) ①

NOTE:
Place a copper plate ④ between the teeth of the primary drive gear ⑤ and primary driven gear to lock them.

















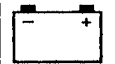



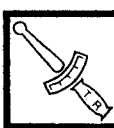

CLUTCH INSPECTION

1. Inspect:
• Friction plates
Wear/damage → Replace the friction plates as a set.
2. Measure:
• Friction plate thickness
Out of specification → Replace the friction plates as a set.
Measure at four places.

Thickness friction plate:
2.3 - 3.1 mm
Wear limit: 2.6 mm

3. Inspect:
• Clutch plate
Damage → Replace the clutch plates as a set.
4. Measure:
• Clutch plate warpage
Out of specification → Replace the clutch plates as a set.
Use a surface plate and a feeler gauge ④.

Wing Bolt clutch plate:
Less than 0.2 mm

① GEN INFO 	② SPEC 	
③ INSP ADJ 	④ ENG 	
⑤ COOL 	⑥ CARB 	
⑦ CHAS 	⑧ ELEC 	
⑨ TRBL SHTG ? 	⑩ 	
⑪ 	⑫ 	
⑬ 	⑭ 	
⑮ 	⑯ 	⑰ 
⑱ 	⑲ 	⑳ 
㉑ 	㉒ 	㉓ 
㉔ 	㉕ New	

EB003000

ILLUSTRATED SYMBOLS

Illustrated symbols ① to ⑨ are printed on the top right of each page and indicate the subject of each chapter.

- ① General information
- ② Specifications
- ③ Periodic inspections and adjustments
- ④ Engine
- ⑤ Cooling system
- ⑥ Carburetion
- ⑦ Chassis
- ⑧ Electrical
- ⑨ Troubleshooting

Illustrated symbols ⑩ to ⑰ are used to identify the specifications appearing in the text.

- ⑩ Can be serviced with engine mounted
- ⑪ Filling fluid
- ⑫ Lubricant
- ⑬ Special tool
- ⑭ Torque
- ⑮ Wear limit, clearance
- ⑯ Engine speed
- ⑰ Ω , V, A







Illustrated symbols ⑱ to ㉓ in the exploded diagrams indicate the types of lubricants and lubrication points.

- ⑱ Apply engine oil
- ⑲ Apply gear oil
- ⑳ Apply molybdenum disulfide oil
- ㉑ Apply wheel bearing grease
- ㉒ Apply lightweight lithium-soap base grease
- ㉓ Apply molybdenum disulfide grease

Illustrated symbols ㉔ to ㉕ in the exploded diagrams indicate where to apply a locking agent ㉔ and when to install new parts ㉕.

- ㉔ Apply locking agent (LOCTITE®)
- ㉕ Replace

CHAPTER TITLES

GENERAL INFORMATION	
	GEN INFO 1
SPECIFICATIONS	
	SPEC 2
PERIODIC INSPECTION AND ADJUSTMENT	
	INSP ADJ 3
ENGINE OVERHAUL	
	ENG 4
CARBURETION	
	CARB 5
CHASSIS	
	CHAS 6
ELECTRICAL	
	ELEC 7
TROUBLESHOOTING	?
	TRBL SHTG 8









CONTENTS

CHAPTER 1. GENERAL INFORMATION

MOTORCYCLE IDENTIFICATION	1-1
VEHICLE IDENTIFICATION NUMBER	1-1
MODEL LABEL	1-1
 IMPORTANT INFORMATION	 1-2
PREPARATION FOR REMOVAL PROCEDURES	1-2
REPLACEMENT PARTS	1-2
GASKETS, OIL SEALS AND O-RINGS	1-2
LOCK WASHERS/PLATES AND COTTER PINS	1-3
BEARINGS AND OIL SEALS	1-3
CIRCLIPS	1-3
 CHECKING OF CONNECTIONS	 1-4
 SPECIAL TOOLS	 1-5

CHAPTER 2. SPECIFICATIONS

GENERAL SPECIFICATIONS	2-1
 MAINTENANCE SPECIFICATIONS	 2-4
ENGINE	2-4
CHASSIS	2-14
ELECTRICAL	2-18
 GENERAL TORQUE SPECIFICATIONS	 2-20
 LUBRICATION POINTS AND LUBRICANT TYPES	 2-21
ENGINE	2-21
CHASSIS	2-22
 LUBRICATION DIAGRAMS	 2-23
 CABLE ROUTING	 2-27

	GEN INFO 1
	SPEC 2
	INSP ADJ 3
	ENG 4
	CARB 5
	CHAS 6
	ELEC 7
	TRBL SHTG 8









CHAPTER 3. PERIODIC INSPECTIONS AND ADJUSTMENTS

INTRODUCTION	3-1
PERIODIC MAINTENANCE/LUBRICATION INTERVALS	3-1
GENERAL MAINTENANCE/LUBRICATION	3-2
FUEL TANK AND SEATS	3-4
ENGINE	3-5
VALVE CLEARANCE ADJUSTMENT	3-5
CARBURETOR SYNCHRONIZATION	3-8
IDLING SPEED ADJUSTMENT	3-10
THROTTLE CABLE ADJUSTMENT	3-11
SPARK PLUG INSPECTION	3-12
IGNITION TIMING CHECK	3-13
COMPRESSION PRESSURE MEASUREMENT	3-15
ENGINE OIL LEVEL INSPECTION	3-17
ENGINE OIL REPLACEMENT	3-18
CLUTCH ADJUSTMENT	3-20
AIR FILTER CLEANING	3-20
CARBURETOR JOINT INSPECTION	3-21
FUEL LINE INSPECTION	3-21
BREATHER HOSE INSPECTION	3-22
EXHAUST SYSTEM INSPECTION	3-22
CHASSIS	3-23
FRONT BRAKE ADJUSTMENT	3-23
REAR BRAKE ADJUSTMENT	3-24
BRAKE FLUID LEVEL INSPECTION	3-25
BRAKE PAD INSPECTION	3-26
BRAKE SHOE INSPECTION	3-26
BRAKE LIGHT SWITCH ADJUSTMENT	3-26
BRAKE HOSE INSPECTION	3-27
AIR BLEEDING (HYDRAULIC BRAKE SYSTEM)	3-27
SHIFT PEDAL ADJUSTMENT	3-28
FINAL GEAR OIL LEVEL INSPECTION	3-29
FINAL GEAR OIL REPLACEMENT	3-30
STEERING HEAD INSPECTION	3-30
FRONT FORK INSPECTION	3-32
REAR SHOCK ABSORBER ADJUSTMENT	3-33
TIRE INSPECTION	3-33
WHEEL INSPECTION	3-36
SPOKE INSPECTION AND TIGHTENING	3-36
CABLE INSPECTION AND LUBRICATION	3-36
LEVER AND PEDAL LUBRICATION	3-37
SIDESTAND LUBRICATION	3-37

ELECTRICAL	3-38
BATTERY INSPECTION	3-38
FUSE INSPECTION	3-43
HEADLIGHT BEAM ADJUSTMENT	3-45
HEADLIGHT BULB REPLACEMENT	3-45

CHAPTER 4. ENGINE

ENGINE REMOVAL	4-1
MUFFLERS, BRAKE PEDAL AND SIDE COVER	4-1
CYLINDER HEAD COVERS	4-3
SIDESTAND AND CRANKCASE COVER (LEFT)	4-5
ENGINE MOUNTING BOLTS	4-6
SHIFT PEDAL INSTALLATION	4-8
BRAKE PEDAL INSTALLATION	4-8
 CYLINDER HEADS	4-9
CYLINDER HEAD REMOVAL	4-11
CYLINDER HEAD INSPECTION	4-12
CYLINDER HEAD INSTALLATION	4-14
 ROCKER ARMS AND CAMSHAFT	4-17
ROCKER ARM AND CAMSHAFT REMOVAL	4-18
ROCKER ARM AND CAMSHAFT INSPECTION	4-18
ROCKER ARM AND CAMSHAFT INSTALLATION	4-19
 VALVES AND VALVE SPRINGS	4-21
VALVE AND VALVE SPRING REMOVAL	4-22
VALVE AND VALVE SPRING INSPECTION	4-22
VALVE AND VALVE SPRING INSTALLATION	4-26
 CYLINDERS AND PISTONS	4-28
PISTON REMOVAL	4-29
CYLINDER AND PISTON INSPECTION	4-29
PISTON RING INSPECTION	4-31
PISTON PIN INSPECTION	4-32
CYLINDER AND PISTON INSTALLATION	4-33
 CLUTCH	4-34
CRANKCASE COVER (RIGHT)	4-34
CLUTCH ASSEMBLY	4-36
CLUTCH REMOVAL	4-38
PRIMARY DRIVE GEAR REMOVAL	4-38
CLUTCH INSPECTION	4-38
PUSH ROD INSPECTION	4-40
PRIMARY DRIVE GEAR INSTALLATION	4-40
CLUTCH INSTALLATION	4-40

	GEN INFO	1
	SPEC	2
	INSP ADJ	3
	ENG	4
	CARB	5
	CHAS	6
	ELEC	7
	TRBL SHTG	8

SHIFT SHAFT	4-42
SHIFT SHAFT INSPECTION	4-43
SHIFT SHAFT INSTALLATION	4-43
OIL PUMP	4-45
OIL PUMP INSPECTION	4-47
AC MAGNETO AND STARTER CLUTCH	4-48
STATOR COIL AND PICKUP COIL	4-48
AC MAGNETO AND STARTER CLUTCH	4-49
AC MAGNETO REMOVAL	4-50
STARTER CLUTCH INSPECTION	4-50
AC MAGNETO INSTALLATION	4-51
CRANKSHAFT AND CONNECTING RODS	4-53
CRANKCASE	4-53
CRANKSHAFT AND CONNECTING RODS	4-55
CRANKCASE SEPARATION	4-56
CRANKSHAFT REMOVAL	4-57
CRANKSHAFT INSPECTION	4-57
CRANKSHAFT INSTALLATION	4-62
CRANKCASE ASSEMBLY	4-63
TRANSMISSION	4-65
SHIFT FORK INSPECTION	4-66
SHIFT CAM INSPECTION	4-66
TRANSMISSION INSPECTION	4-66
TRANSMISSION INSTALLATION	4-68
MIDDLE GEAR	4-69
MIDDLE DRIVEN PINION GEAR	4-69
MIDDLE DRIVE PINION GEAR	4-71
MIDDLE DRIVEN PINION GEAR REMOVAL	4-72
MIDDLE DRIVE PINION GEAR REMOVAL	4-73
MIDDLE GEAR INSPECTION	4-74
MIDDLE DRIVE PINION GEAR INSTALLATION	4-74
MIDDLE DRIVEN PINION GEAR INSTALLATION	4-75
MIDDLE DRIVE GEAR SHIM SELECTION	4-78
GEAR BACKLASH ADJUSTMENT	4-79

CHAPTER 5. CARBURETION

CARBURETOR	5-1
CARBURETOR INSPECTION	5-4
CARBURETOR ASSEMBLY	5-5
FUEL LEVEL ADJUSTMENT	5-7
THROTTLE POSITION SENSOR (TPS) INSPECTION AND ADJUSTMENT	5-8

AIR INDUCTION SYSTEM (AIS)	5-10
AIR INJECTION	5-10
AIR CUT-OFF VALVE	5-10
AIR INDUCTION SYSTEM INSPECTION	5-11

CHAPTER 6. CHASSIS









FRONT WHEEL AND BRAKE DISC	6-1
FRONT WHEEL DISASSEMBLY	6-3
FRONT WHEEL INSPECTION	6-3
BRAKE DISK INSPECTION	6-4
FRONT WHEEL ASSEMBLY	6-5
FRONT WHEEL INSTALLATION	6-5
FRONT WHEEL STATIC BALANCE ADJUSTMENT	6-6

FRONT BRAKE	6-8
FRONT BRAKE PADS	6-8
BRAKE PAD REPLACEMENT	6-9
MASTER CYLINDER	6-11
MASTER CYLINDER INSPECTION	6-13
MASTER CYLINDER ASSEMBLY	6-13
MASTER CYLINDER INSTALLATION	6-14
FRONT BRAKE CALIPER	6-16
CALIPER DISASSEMBLY	6-18
CALIPER INSPECTION	6-18
CALIPER ASSEMBLY	6-19
CALIPER INSTALLATION	6-19

REAR WHEEL AND REAR BRAKE	6-21
MUFFLER AND REAR BRAKE ROD	6-21
REAR WHEEL	6-22
REAR WHEEL REMOVAL	6-25
REAR WHEEL DISASSEMBLY	6-25
REAR WHEEL INSPECTION	6-25
REAR BRAKE INSPECTION	6-26
REAR WHEEL ASSEMBLY	6-27
REAR BRAKE ASSEMBLY	6-28
REAR WHEEL INSTALLATION	6-28
REAR WHEEL STATIC BALANCE ADJUSTMENT	6-29

FRONT FORK	6-30
FRONT FORK DISASSEMBLY	6-34
FRONT FORK INSPECTION	6-35
FRONT FORK ASSEMBLY	6-35
FRONT FORK INSTALLATION	6-38

HANDLEBAR	6-40
------------------------	------

	GEN INFO	1
	SPEC	2
	INSP ADJ	3
	ENG	4
	CARB	5
	CHAS	6
	ELEC	7
	TRBL SHTG	8

HANDLEBAR INSPECTION	6-42
HANDLEBAR INSTALLATION	6-42
STEERING HEAD	6-45
STEERING HEAD REMOVAL	6-47
STEERING HEAD INSPECTION	6-47
STEERING HEAD INSTALLATION	6-47
REAR SHOCK ABSORBER AND SWINGARM	6-48
HANDLING NOTES	6-50
NOTES ON DISPOSAL	6-50
REAR SHOCK ABSORBER INSPECTION	6-50
SWINGARM INSTALLATION	6-51
REAR SHOCK ABSORBER INSTALLATION	6-51
SWINGARM INSPECTION	6-52
SHAFT DRIVE	6-53
TROUBLESHOOTING	6-53
FINAL GEAR BACKLASH MEASUREMENT	6-57
FINAL GEAR BACKLASH ADJUSTMENT	6-58
DRIVE SHAFT	6-59
FINAL GEAR	6-60
FINAL DRIVE GEAR DISASSEMBLY	6-61
FINAL DRIVE ROLLER BEARING REMOVAL AND REASSEMBLY	6-61
FINAL DRIVE/RING GEAR POSITIONING	6-63
DRIVE SHAFT INSPECTION	6-67
FINAL GEAR CASE INSTALLATION	6-67









CHAPTER 7. ELECTRICAL

ELECTRICAL COMPONENTS	7-1
SWITCH INSPECTION	7-2
SWITCH INSPECTION	7-2
INSPECTING A SWITCH SHOWN IN THE MANUAL	7-2
SWITCH CONTINUITY INSPECTION	7-3
IGNITION SYSTEM	7-5
CIRCUIT DIAGRAM	7-5
TROUBLESHOOTING	7-6
ELECTRIC STARTING SYSTEM	7-11
CIRCUIT DIAGRAM	7-11
STARTING CIRCUIT OPERATION	7-12
TROUBLESHOOTING	7-13

STARTER MOTOR	7-17
STARTER MOTOR INSPECTION	7-18
STARTER MOTOR ASSEMBLY	7-19
CHARGING SYSTEM	7-21
CIRCUIT DIAGRAM	7-21
TROUBLESHOOTING	7-22
LIGHTING SYSTEM	7-24
CIRCUIT DIAGRAM	7-24
TROUBLESHOOTING	7-25
LIGHTING SYSTEM CHECK	7-27
SIGNAL SYSTEM	7-30
CIRCUIT DIAGRAM	7-30
TROUBLESHOOTING	7-32
SIGNAL SYSTEM CHECK	7-34
FUEL PUMP SYSTEM	7-38
CIRCUIT DIAGRAM	7-38
FUEL PUMP CIRCUIT OPERATION	7-39
TROUBLESHOOTING	7-40
FUEL PUMP TEST	7-43
CARBURETOR HEATER SYSTEM	7-44
CIRCUIT DIAGRAM	7-44
TROUBLESHOOTING	7-45
SELF-DIAGNOSIS	7-49
TROUBLESHOOTING	7-50

CHAPTER 8. TROUBLESHOOTING

STARTING FAILURE/HARD STARTING	8-1
FUEL SYSTEM	8-1
ELECTRICAL SYSTEM	8-1
COMPRESSION SYSTEM	8-2
POOR IDLE SPEED PERFORMANCE	8-2
POOR IDLE SPEED PERFORMANCE	8-2
POOR MEDIUM-AND HIGH-SPEED PERFORMANCE	8-2
POOR MEDIUM-AND HIGH-SPEED PERFORMANCE	8-2

	GEN INFO	1
	SPEC	2
	INSP ADJ	3
	ENG	4
	CARB	5
	CHAS	6
	ELEC	7
	TRBL SHTG	8

FAULTY GEAR SHIFTING	8-3
HARD SHIFTING	8-3
SHIFT PEDAL DOES NOT MOVE	8-3
JUMPS-OUT-OF GEAR	8-3
CLUTCH SLIPPING/Dragging	8-3
CLUTCH SLIPPING	8-3
CLUTCH DRAGGING	8-3
OVERHEATING	8-4
OVERHEATING	8-4
FAULTY BRAKE	8-4
POOR BRAKING EFFECT	8-4
FRONT FORK OIL LEAKAGE AND FRONT FORK MALFUNCTION	8-4
MALFUNCTION	8-4
OIL LEAKAGE	8-4
UNSTABLE HANDLING	8-5
UNSTABLE HANDLING	8-5
FAULTY LIGHTING AND SIGNAL SYSTEMS	8-5
HEADLIGHT DOES NOT LIGHT	8-5
BULB BURNT OUT	8-5
FLASHER DOES NOT LIGHT	8-5
FLASHER BLINKS SLOWLY	8-5
FLASHER REMAINS LIT	8-5
FLASHER BLINKS QUICKLY	8-5
HORN DOES NOT SOUND	8-5

XVS650AK(C) WIRING DIAGRAM

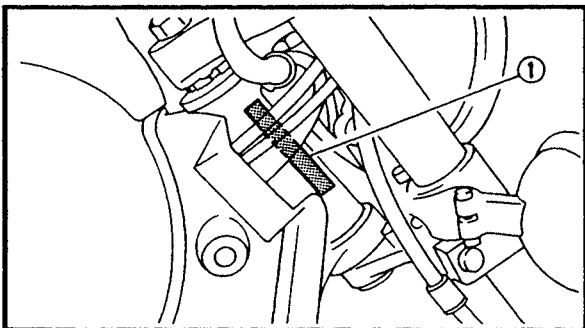

EB100000

**GENERAL INFORMATION
MOTORCYCLE IDENTIFICATION**

EB100010

VEHICLE IDENTIFICATION NUMBER

The vehicle identification number ① is stamped into the right side of the steering head.

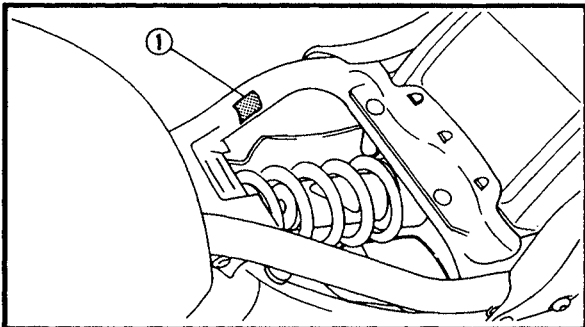

MODEL LABEL

The model label ① is affixed to the frame. This information will be needed to order spare parts.

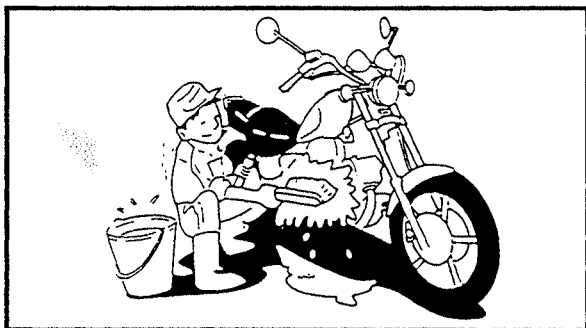

EB101000

IMPORTANT INFORMATION

**PREPARATION FOR REMOVAL
PROCEDURES**

1. Remove all dirt, mud, dust and foreign material before removal and disassembly.

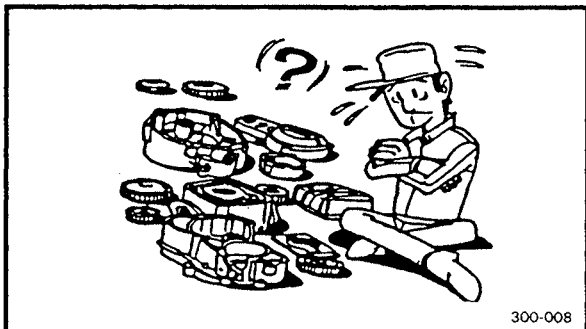

300-008

2. Use proper tools and cleaning equipment. Refer to the "SPECIAL TOOLS" section.

3. When disassembling the machine, always keep mated parts together. This includes gears, cylinders, pistons and other parts that have been "mated" through normal wear. Mated parts must always be reused or replaced as an assembly.

4. During machine disassembly, clean all parts and place them in trays in the order of disassembly. This will speed up assembly and allow for the correct installation of all parts.

5. Keep all parts away from any source of fire.

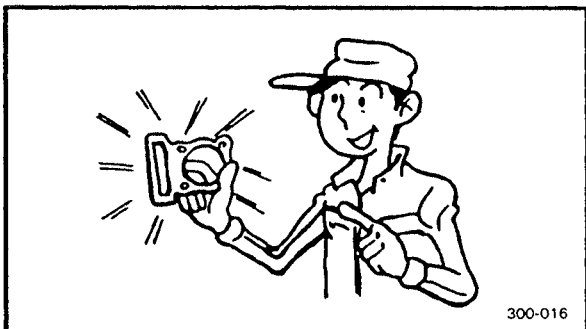

300-016

EB101010

REPLACEMENT PARTS

1. Use only genuine Yamaha parts for all replacements. Use oil and grease recommended by Yamaha for all lubrication jobs. Other brands may be similar in function and appearance, but inferior in quality.

EB101020

GASKETS, OIL SEALS AND O-RINGS

1. Replace all gaskets, seals and O-rings when overhauling the engine. All gasket surfaces, oil seal lips and O-rings must be cleaned.

2. Properly oil all mating parts and bearings during reassembly. Apply grease to the oil seal lips.

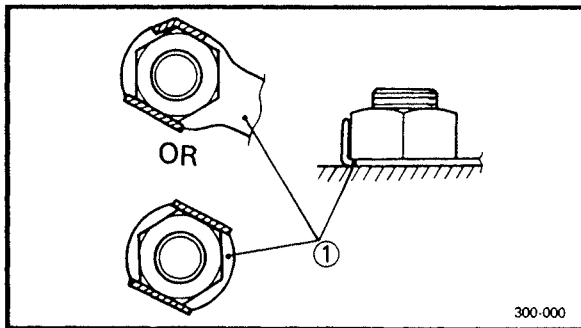

EB101030

LOCK WASHERS/PLATES AND COTTER PINS

1. Replace all lock washers/plates ① and cotter pins after removal. Bend lock tabs along the bolt or nut flats after the bolt or nut has been tightened to specification.

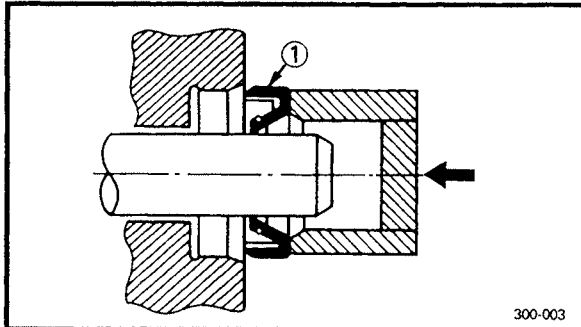

EB101040

BEARINGS AND OIL SEALS

1. Install bearings and oil seals so that the manufacturer's marks or numbers are visible. When installing oil seals, apply a light coating of lightweight lithium base grease to the seal lips. Oil bearings liberally when installing, if appropriate.

① Oil seal

CAUTION:

Do not use compressed air to spin the bearings dry. This will damage the bearing surfaces.

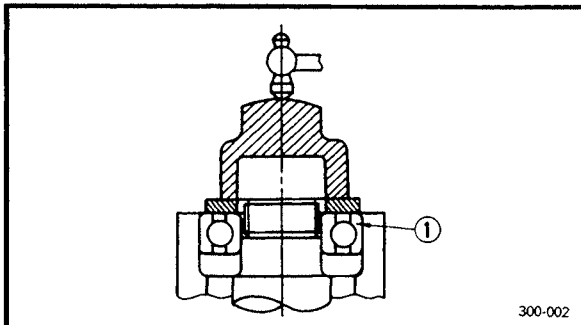

① Bearing

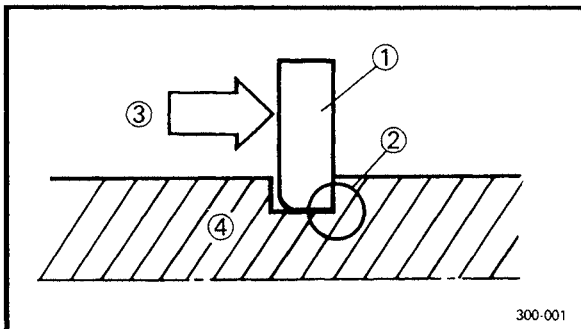

EB101050

CIRCLIPS

1. Check all circlips carefully before reassembly. Always replace piston pin clips after one use. Replace distorted circlips. When installing a circlip ①, make sure that the sharp-edged corner ② is positioned opposite the thrust ③ it receives. See sectional view.

④ Shaft

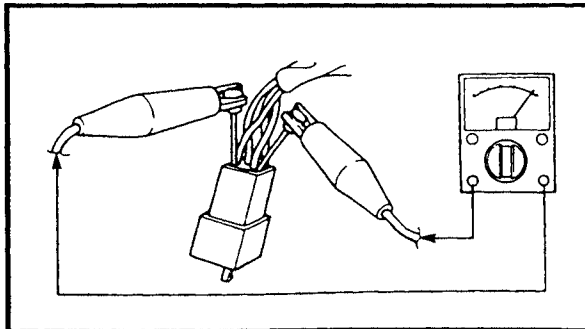
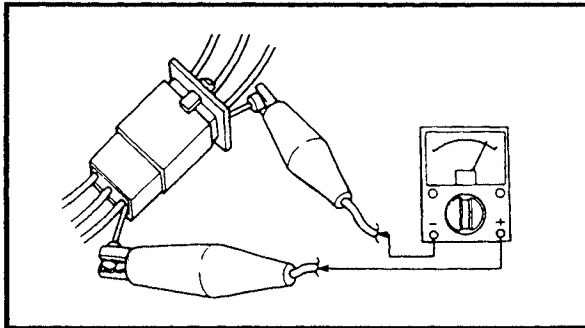
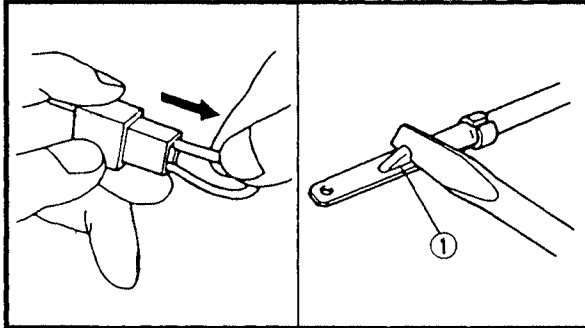
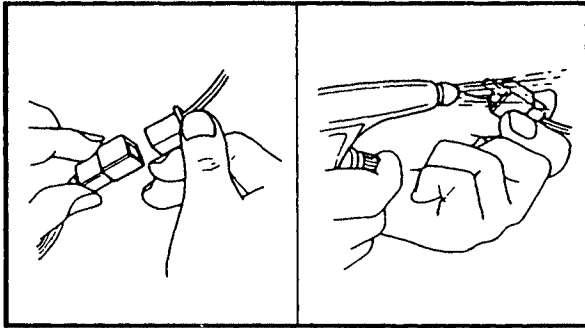

EB801000

CHECKING OF CONNECTIONS

Check the connectors for stains, rust, moisture, etc.

1.Disconnect:

- Connector

2.Check:

- Connector

Moisture → Dry each terminal with an air blower.

Stains/rust → Connect and disconnect the terminals several times.

3.Check:

- Connector leads

Looseness → Bend up the pin ① and connect the terminals.

4.Connect:

- Connector terminals

NOTE:

The two terminals "click" together.

5.Check:

- Continuity (using a pocket tester)

NOTE:

- If there is no continuity, clean the terminals.

- When checking the wire harness be sure to perform steps 1 to 3.

- As a quick remedy, use a contact revitalizer available at most part stores.

- Check the connector with a pocket tester as shown.



EB102001

SPECIAL TOOLS

The following special tools are necessary for complete and accurate tune-up and assembly. Use only the appropriate special tools; this will help prevent damage caused by the use of inappropriate tools or improvised techniques. Special tools may differ by shape and part number from country to country. In such a case, two types are provided.

When placing an order, refer to the list provided below to avoid any mistakes.

P/N.YM-, YU-

For US, CDN

YS-, YK- ACC-

P/N.90890-

Except for US, CDN

Tool No.	Tool name / How to use	Illustration
Weight YU-1083-3 90890-01084 Bolt YU-1083-2 90890-01085	Slide hammer bolt / weight These tools are used to remove the rocker arm shaft.	
YM-01231 90890-01231	Final gear backlash band This tool is needed when measuring final gear backlash.	
YU-01304 90890-01304	Piston pin puller This tool is used to remove the piston pin.	
YM-01312-A 90890-01312	Fuel level gauge This gauge is used to measure the fuel level in the float chamber.	
T-handle YM-01326 90890-01326 Holder YM-01388 90890-01388	T-handle / damper rod holder These tools are needed to loosen and tighten the damper rod holding bolt.	
Puller YU-33270 90890-01362 Adapter YM-33282 90890-04089	Flywheel puller / adapter These tools are needed to remove the rotor.	
Weight YM-33963 90890-01367 Adapter YM-8020 90890-01381	Fork seal driver weight / adapter These tools are needed when installing the slide metal, oil seal and dust seal into the fork.	