



**YAMAHA**

# **XT225-C (D-G)**

396 motorcycle

## **Service Manual**

LIT-11616-XT-25

**YAMAHA**

**XT225H  
XT225HC**

**SUPPLEMENTARY  
SERVICE MANUAL**

LIT-11616-10-05

---

## **FOREWORD**

This Supplementary Service Manual has been prepared to introduce new service and data for the XT225H/XT225HC. For complete service information procedures it is necessary to use this Supplementary Service Manual together with the following manual.

**XT225D/XT225DC SERVICE MANUAL: 4BE-28197-20**

**XT225H/XT225HC  
SUPPLEMENTARY  
SERVICE MANUAL**

**©1995 by Yamaha Motor Co., Ltd.**

**1st Edition, May 1995**

**All rights reserved.**

**Any reprinting or unauthorized use  
without the written permission of**

**Yamaha Motor Co., Ltd.**

**is expressly prohibited.**

---

## NOTICE

This manual was written by Yamaha Motor Company Ltd. primarily for use by Yamaha dealers and qualified mechanics. It is not possible to put an entire mechanic's education into one manual, so persons using this book to perform maintenance and repairs on Yamaha motorcycles should have a basic understanding of the mechanical concepts and procedures inherent in motorcycle repair technology. Without such knowledge, attempted repairs or service to the motorcycle may render it unfit to use and/or unsafe.

### for USA, California

This model has been designed and manufactured to perform within certain specifications in regard to performance and emissions. Proper service with the correct tools is necessary to ensure that the motorcycle will operate as designed. If there is any question about a service procedure, it is imperative that you contact a Yamaha dealer for any service information changes that apply to this model. This policy is intended to provide the customer with the most satisfaction from his motorcycle and to conform with federal environmental quality objectives.

Yamaha Motor Company, Ltd. is continually striving to improve all models manufactured by Yamaha. Modifications and significant changes in specifications or procedures will be forwarded to all Authorized Yamaha dealers and will, where applicable, appear in future editions of this manual.

---

### NOTE:

#### FOR USA, California:

This Service Manual contains information regarding periodic maintenance to the emission control system. Please read this material carefully.

---

## PARTICULARLY IMPORTANT INFORMATION

This material is distinguished by the following notation.



The Safety Alert Symbol means ATTENTION! BECOME ALERT! YOUR SAFETY IS INVOLVED!

### **WARNING**

Failure to follow WARNING instructions could result in severe injury or death to the motorcycle operator, a bystander, or a person inspecting or repairing the motorcycle.

### **CAUTION:**

A CAUTION indicates special precautions that must be taken to avoid damage to the motorcycle.

### **NOTE:**

A NOTE provides key information to make procedures easier or clearer.

# HOW TO USE THIS MANUAL

## CONSTRUCTION OF THIS MANUAL

This manual consists of chapters for the main categories of subjects. (See "Illustrated symbols")

- 1st title ①: This is a chapter with its symbol on the upper right of each page.
- 2nd title ②: This title appears on the upper of each page on the left of the chapter symbol. (For the chapter "Periodic inspection and adjustment" the 3rd title appears.)
- 3rd title ③: This is a final title.

## MANUAL FORMAT

All of the procedures in this manual are organized in a sequential, step-by-step format. The information has been compiled to provide the mechanic with an easy to read, handy reference that contains comprehensive explanations of all disassembly, repair, assembly, and inspections.

A set of particularly important procedure ④ is placed between a line of asterisks "\*" with each procedure preceded by "●".









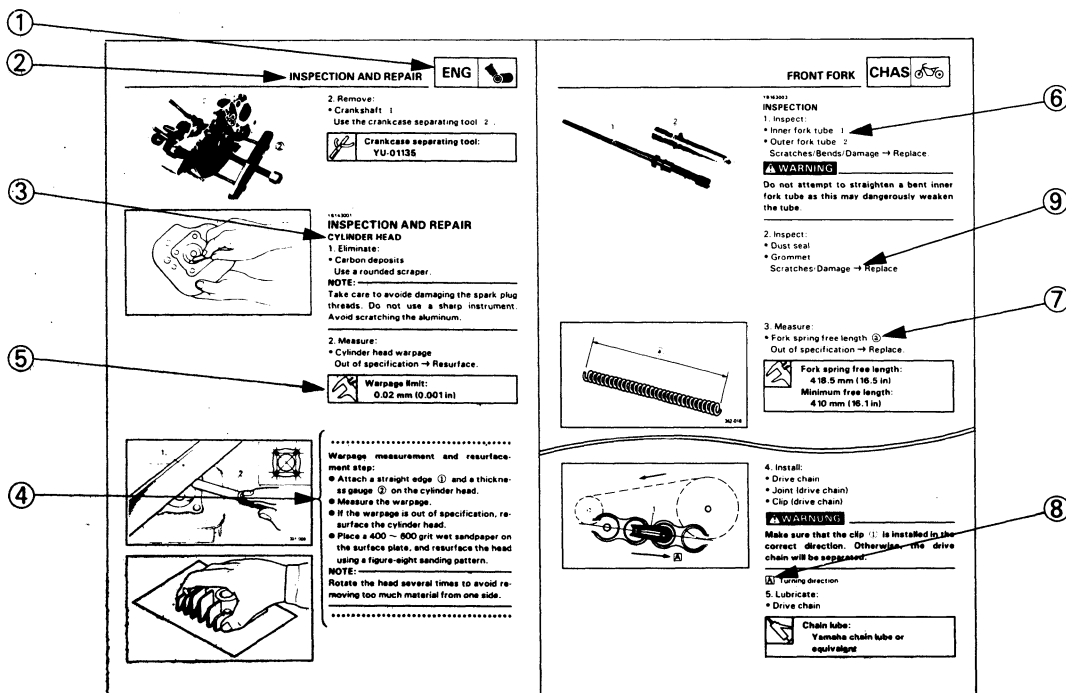







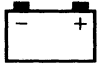



## IMPORTANT FEATURES

- Data and a special tool are framed in a box preceded by a relevant symbol ⑤.
- An encircled numeral ⑥ indicates a part name, and an encircled alphabetical letter data or an alignment mark ⑦, the others being indicated by an alphabetical letter in a box ⑧.
- A condition of a faulty component will precede an arrow symbol and the course of action required the symbol ⑨.

## EXPLODED DIAGRAM

Each chapter provides exploded diagrams before each disassembly section for ease in identifying correct disassembly and assembly procedures.



① GEN INFO 	② SPEC 	
③ INSP ADJ 	④ ENG 	
⑤ COOL 	⑥ CARB 	
⑦ CHAS 	⑧ ELEC 	
⑨ TRBL SHTG ?	⑩ 	
⑪ 	⑫ 	
⑬ 	⑭ 	
⑮ 	⑯ 	
⑰ 	⑱ 	⑲ 
⑳ 	㉑ 	㉒ 
㉓ 	㉔ <b>New</b>	

## ILLUSTRATED SYMBOLS (Refer to the illustration)

Illustrated symbols ① to ⑨ are designed as thumb tabs to indicate the chapter's number and content.

- ① General information
- ② Specifications
- ③ Periodic inspection and adjustment
- ④ Engine
- ⑤ Cooling system
- ⑥ Carburetion
- ⑦ Chassis
- ⑧ Electrical
- ⑨ Troubleshooting

Illustrated symbols ⑩ to ⑯ are used to identify the specifications appearing in the text.

- ⑩ Filling fluid
- ⑪ Lubricant
- ⑫ Special tool
- ⑬ Tightening
- ⑭ Wear limit, clearance
- ⑮ Engine speed
- ⑯  $\Omega$ , V, A

Illustrated symbols ⑰ to ㉓ in the exploded diagram indicate grade of lubricant and location of lubrication point.

- ⑰ Apply engine oil
- ⑱ Apply gear oil
- ⑲ Apply molybdenum disulfide oil
- ㉑ Apply wheel bearing grease
- ㉒ Apply lightweight lithium-soap base grease
- ㉓ Apply molybdenum disulfide grease
- ㉔ Apply locking agent (LOCTITE<sup>®</sup>)
- ㉕ Use new one

---

## CONTENTS

<b>GENERAL INFORMATION</b> .....	1
<b>MOTORCYCLE IDENTIFICATION</b> .....	1
VEHICLE IDENTIFICATION NUMBER .....	1
ENGINE SERIAL NUMBER .....	1
<b>SPECIFICATIONS</b> .....	2
<b>GENERAL SPECIFICATIONS</b> .....	2
<b>MAINTENANCE SPECIFICATIONS</b> .....	3
ENGINE .....	3
CHASSIS .....	6
<b>LUBRICATION POINTS AND LUBRICANT TYPE</b> .....	7
CHASSIS .....	7
<b>CABLE ROUTING</b> .....	8
<b>ENGINE</b> .....	12
<b>ENGINE ASSEMBLY AND ADJUSTMENT</b> .....	12
CLUTCH AND OIL PUMP .....	12
<b>CHASSIS</b> .....	13
<b>FRONT FORK</b> .....	13

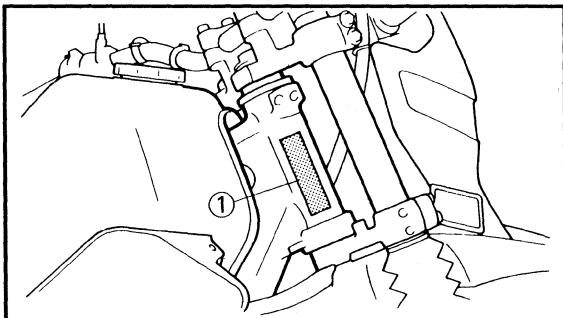

**GENERAL INFORMATION**  
**MOTORCYCLE IDENTIFICATION**  
**VEHICLE IDENTIFICATION NUMBER**

The vehicle identification number ① is stamped into the right side of the steering head.

**Starting serial number:**  
**JYA4BEE0\*TA035101**  
**(USA-Except for California)**  
**JYA4BEC0\*TA040101**  
**(USA-For California)**  
**JYA4BEN0\*TA042101 (CDN)**

**NOTE:** \_\_\_\_\_

The vehicle identification number is used to identify your motorcycle and may be used to register your motorcycle with the licensing authority in your state.

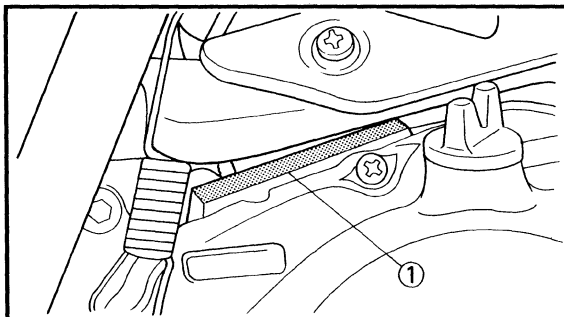

**ENGINE SERIAL NUMBER**

The engine serial number ① is stamped into the elevated part of the right rear section of the engine.

**Starting serial number:**  
**4BE-035101**  
**(USA-Except for California)**  
**4BE-040101**  
**(USA-For California)**  
**4BE-042101 (CDN)**

**NOTE:** \_\_\_\_\_

- The first three digits of these numbers are for model identifications; the remaining digits are the unit production number.
- Designs and specifications are subject to change without notice.

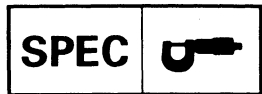

**SPECIFICATIONS**

**GENERAL SPECIFICATIONS**

Model	XT225H/HC
Model code number:	4BED: XT225H (USA-Except for California) 4BEE: XT225HC (USA-For California) 4BEF: XT225H (CDN)
Vehicle identification number:	JYA4BEE0*TA035101 (USA-Except for California) JYA4BEC0*TA040101 (USA-For California) JYA4BEN0*TA042101 (CDN)
Engine starting number:	4BE-035101 (USA-Except for California) 4BE-040101 (USA-For California) 4BE-042101 (CDN)
Shock absorber: Front Rear	Coil-Spring/Oil damper Coil-Gas spring/Oil damper



# MAINTENANCE SPECIFICATIONS





## TIGHTENING TORQUE

Part to be tightened	Part name	Thread size	Q'ty	Tightening torque			Remarks
				Nm	m•kg	ft•lb	
Cylinder head	Crossrecessed hexagon bolt	M6	1	7	0.7	5.1	Oilcheck
Cylinder head and cylinder	Flange bolt	M8	4	22	2.2	17	Apply oil to the washer
Cylinder head	Bolt	M8	2	20	2.0	14	
Cylinder head side cover 3	Panhead screw	M6	2	7	0.7	5.1	Use lock washer
Cylinder head side cover 12	Bolt	M6	5	10	1.0	7.2	
Plate	Bolt	M6	2	8	0.8	5.8	
Spark plug	–	M12	1	17.5	1.75	12.5	Use lock washer
Cylinder	Bolt	M6	2	10	1.0	7.2	
Balance weight gear	Nut	M14	1	50	5.0	36	Use lock washer
AC generator rotor	Bolt	M10	1	50	5.0	36	
Valve clearance	Nut	M6	2	13.5	1.35	10	Use lock washer
Cam sprocket	Bolt	M10	1	60	6.0	43	
Tensioner	Bolt	M6	2	10	1.0	7.2	Use lock washer
Stopper guide 2	Bolt	M6	2	8	0.8	5.8	
Oil pump assembly	Flat head screw	M6	3	7	0.7	5.1	Use lock washer
Drain plug 1	–	M35	1	43	4.3	31	
Element cover	Panhead screw	M6	1	7	0.7	5.1	Use lock washer
Element cover	Panhead screw	M6	1	7	0.7	5.1	
Element cover	Bolt	M6	1	10	1.0	7.2	Use lock washer
Carburetor joint 1	Button head bolt	M6	2	12	1.2	8.7	
Carburetor	Hose clamp	M5	1	2	0.2	1.4	Use lock washer
Air filter case fitting (front)	Screw with washer	M6	1	10	1.0	7.2	
Air filter case fitting (rear)	Hexagon bolt with washer	M6	2	10	1.0	7.2	Use lock washer
Muffler mounting	Flange bolt	M8	2	40	4.0	29	
Exhaust pipe fitting	Bolt	M6	2	10	1.0	7.2	Use lock washer
Exhaust pipe protector	Bind head screw	M6	3	7	0.7	5.1	
Muffler protector	Screw	M6	2	7	0.7	5.1	Use lock washer
Exhaust pipe and muffler link	Bolt	M8	1	20	2.0	14	Tighten starter motor together
Case 1 & 2	Panhead screw	M6	7	7	0.7	5.1	
Case 1 & 2	Panhead screw	M6	2	7	0.7	5.1	
Case 1 & 2	Panhead screw	M6	2	7	0.7	5.1	
Case 1 & 2	Panhead screw	M6	1	7	0.7	5.1	

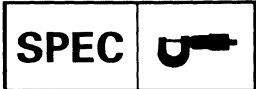
# MAINTENANCE SPECIFICATIONS



Part to be tightened	Part name	Thread size	Q'ty	Tightening torque			Remarks
				Nm	m•kg	ft•lb	
Crankcase cover 1	Panhead screw	M6	6	7	0.7	5.1	
Crankcase cover 1	Panhead screw	M6	2	7	0.7	5.1	
Clamp	Panhead screw	M6	1	7	0.7	5.1	
Crankcase cover 2	Panhead screw	M6	2	7	0.7	5.1	
Crankcase cover 3	Panhead screw	M6	5	7	0.7	5.1	
Crankcase cover 3	Panhead screw	M6	3	7	0.7	5.1	
Crankcase cover 3	Panhead screw	M6	2	7	0.7	5.1	
Primary drive gear	Nut	M14	1	50	5.0	36	Use lock washer
Clutch spring	Screw with washer	M5	4	6	0.6	4.3	
Clutch boss	Nut	M14	1	70	7.0	51	Use lock washer
Push lever assembly stopper	Screw	M8	1	12	1.2	8.7	
Push lever clearance adjusting	Nut	M6	1	8	0.8	5.8	
Drive sprocket	Bolt	M6	2	10	1.0	7.2	
Shift pedal	Bolt	M6	1	10	1.0	7.2	
Segment	Screw	M6	1	12	1.2	8.7	Torques bolt 
Pulser coil	Panhead screw	M6	2	7	0.7	5.1	
Neutral switch assembly	-	M10	1	20	2.0	14	
Stator coil	Panhead screw with washer	M5	3	4	0.4	2.9	

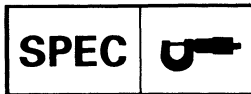

**CHASSIS**

Model	XT225H/HC
<p>Front suspension:</p> <p>Front fork travel</p> <p>Front spring free length</p> <p>&lt;Minimum free length&gt;</p> <p>Spring rate</p> <p>Stroke</p> <p>Optional spring</p> <p>Oil capacity</p> <p>Oil level</p> <p>Oil grade</p>	<p>255 mm (8.9 in)</p> <p>594.7 mm (23.41 in)</p> <p>588.8 mm (23.18 in)</p> <p>(K1) 3.5 N/mm (0.35 kg/mm, 19.6 lb/in)</p> <p>(K2) 4.0 N/mm (0.40 kg/mm, 22.4 lb/in)</p> <p>(K1) Zero ~ 110 mm (Zero~4.33 in)</p> <p>(K2) 110~230 mm (4.33~9.06 in)</p> <p>No</p> <p>366 cm<sup>3</sup> (12.9 Imp oz, 12.4 US oz)</p> <p>140 mm (5.5 in)</p> <p>From top of inner tube fully compressed without spring</p> <p>Fork oil 10W or equivalent</p>
<p>Rear suspension:</p> <p>Shock absorber travel</p> <p>Spring free length</p> <p>Fitting length</p> <p>Spring-rate</p> <p>Stroke</p> <p>Optional spring</p> <p>Enclosed gas pressure</p>	<p>72 mm (2.8 in)</p> <p>189 mm (7.4 in)</p> <p>174 mm (6.9 in)</p> <p>(K1) 61.5 N/mm (6.15 mm, 344 lb/in)</p> <p>(K1) Zero~87 mm (Zero~3.4 in)</p> <p>No</p> <p>2000 kPa (20 kg/cm<sup>2</sup>, 284 psi)</p>

**LUBRICATION POINTS AND LUBRICANT TYPE**  
**CHASSIS**

Lubrication points (part name)	Lubricant type
Gear unit (speedometer)	
Oil seal lips (all)	
Wheel axle (front wheel and rear wheel)	
Rear wheel hub	
Rear brake shoe plate, camshaft and pivoting pin	
Bush (swingarm) and thrust cover	
Collar (swingarm)	
Pivot shaft (swingarm)	
Bush (rear shock absorber)	
Thrust cover (rear shock absorber and relay arm)	
Bushes (relay arm and connecting arm)	
Collar (relay arm and connecting arm)	
Bushes (connecting arm and frame)	
Collar (connecting arm and frame)	
Bushes (relay arm and swingarm) and thrust cover	
Collars (relay arm and swingarm)	
Pivoting points (brake pedal shaft and frame)	
Bearing and balls (steering head)	
Tube guide (right grip)	
Pivoting points (brake lever and clutch lever)	
Pivoting point (sidestand)	
Bushes (chain tensioner)	

**CABLE ROUTING**

- ① Clutch cable
- ② Master cylinder
- ③ Front brake hose
- ④ Throttle cable
- ⑤ Band
- ⑥ Throttle cable
- ⑦ Band
- ⑧ Clutch cable
- ⑨ Handlebar switch lead (left)
- ⑩ Clutch switch lead
- ⑪ Speedometer lead
- ⑫ Flasher light lead (left)
- ⑬ Speedometer cable
- ⑭ Wireharness
- ⑮ Flasher light lead (right)
- ⑯ Main switch lead
- ⑰ Pilot box lead
- ⑱ Brake hose
- ⑲ Front brake switch lead
- ⑳ Handlebar switch lead (right)

- A** Pass the starter cable to the front of the clutch cable and the throttle cable.
- B** Pass the brake hose through the guide.
- C** 10°
- D** Pass the throttle cable inside of the clutch cable.
- E** Pass the wireharness between the under bracket and the front fender.
- F** Align the locating tape on the wireharness with the headlight stay.

- G** Procedure
1. Connect the wires to the flasher light (right), pilot box, front brake switch, handlebar switch (right) and main switch.
  2. Connect the wires to the clutch switch, handlebar switch (left), meters and flasher light (left), crossing the wires over the wires used in step 1.
  3. After the wiring is completed, put the coupler underneath the meter and pilot box.
  4. Clamp the wires at the point where taping will stop near the wireharness. (Locate the protection taped portion above the headlight rim.)

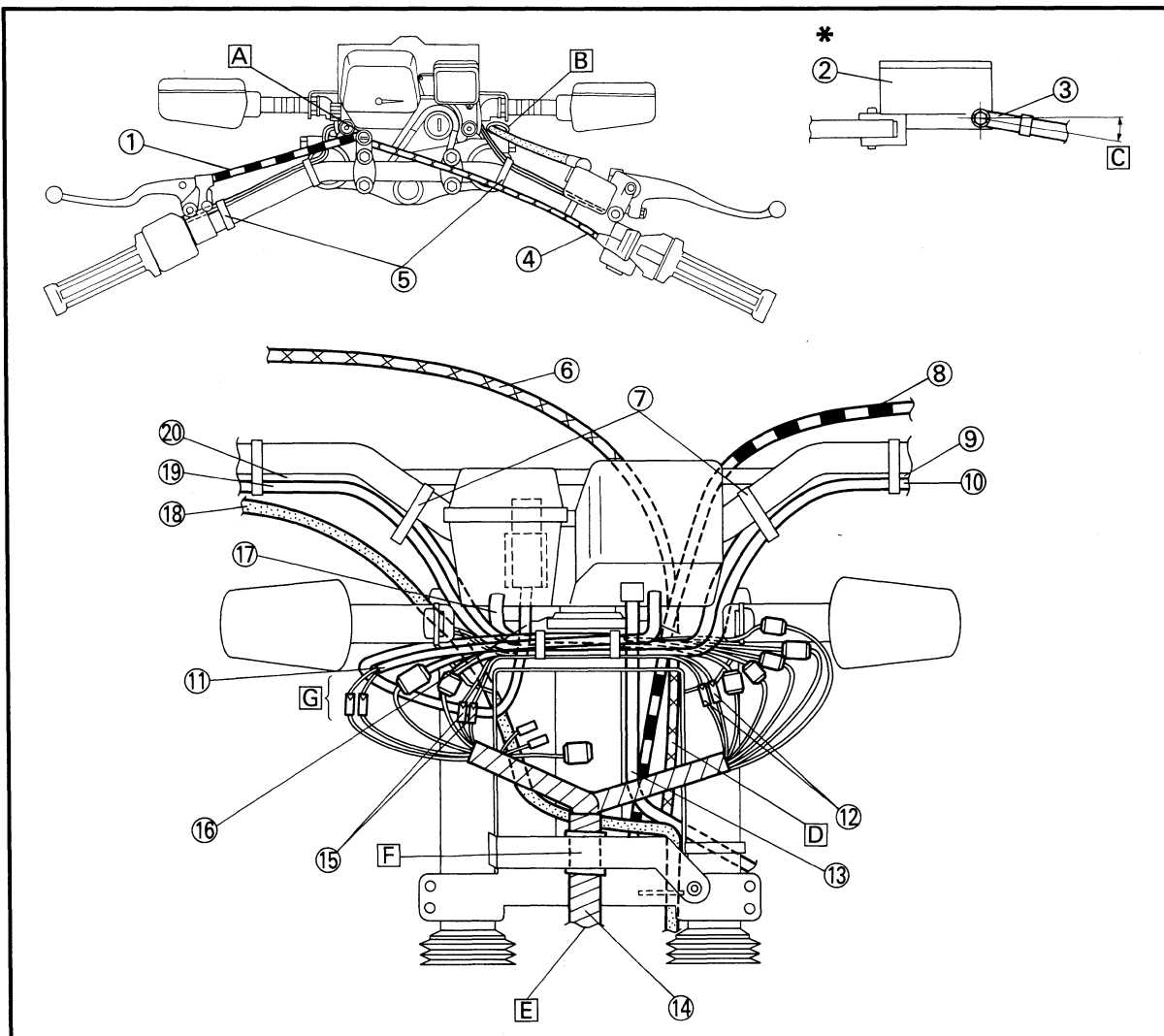

# CABLE ROUTING

SPEC



- |   |  |   |
|---|--|---|
| <ul style="list-style-type: none"> <li>① Horn lead</li> <li>② Cable guide</li> <li>③ Starter cable</li> <li>④ Ignition coil</li> <li>⑤ Band</li> <li>⑥ Clamp</li> <li>⑦ Fuel pipe</li> <li>⑧ Air vent pipe</li> <li>⑨ Overflow pipe</li> <li>⑩ Clamp</li> <li>⑪ Air cleaner</li> <li>⑫ Drain pipe</li> <li>⑬ Sidestand switch lead</li> <li>⑭ Sidestand switch</li> <li>⑮ Crankcase breather hose</li> <li>⑯ Flywheel magneto lead</li> <li>⑰ Seat pillar (left)</li> <li>⑱ Clamp</li> <li>⑲ Overflow pipe</li> </ul> | <ul style="list-style-type: none"> <li>⑳ Carburetor air vent hose (right and left)</li> <li>㉑ Holder</li> <li>㉒ Clutch cable</li> <li>㉓ Guide</li> <li>㉔ Cable holder</li> <li>㉕ Front brake hose</li> <li>㉖ Cable band</li> <li>㉗ Speedometer gear unit</li> <li>㉘ Speedometer cable</li> <li>㉙ Cable holder</li> <li>㉚ Guide</li> <li>A Pass the throttle cable, the clutch cable and the starter cable inside of the guide and pass the starter cable inside of the clutch cable and throttle cable.</li> </ul> | <ul style="list-style-type: none"> <li>B This band has slack within interference (Do not contact the engine.)</li> <li>C Guide (engine side)</li> <li>D To engine</li> <li>E To start motor</li> <li>F Clamp the brake hose.</li> <li>G Clamp the brake hose and the speedometer cable with the band.</li> <li>H Clamp the brake hose to the cable holder and pass the meter cable through the clamp.</li> <li>I Pass the brake hose inside and the meter cable outside through the guide.</li> </ul> |
|---|--|---|

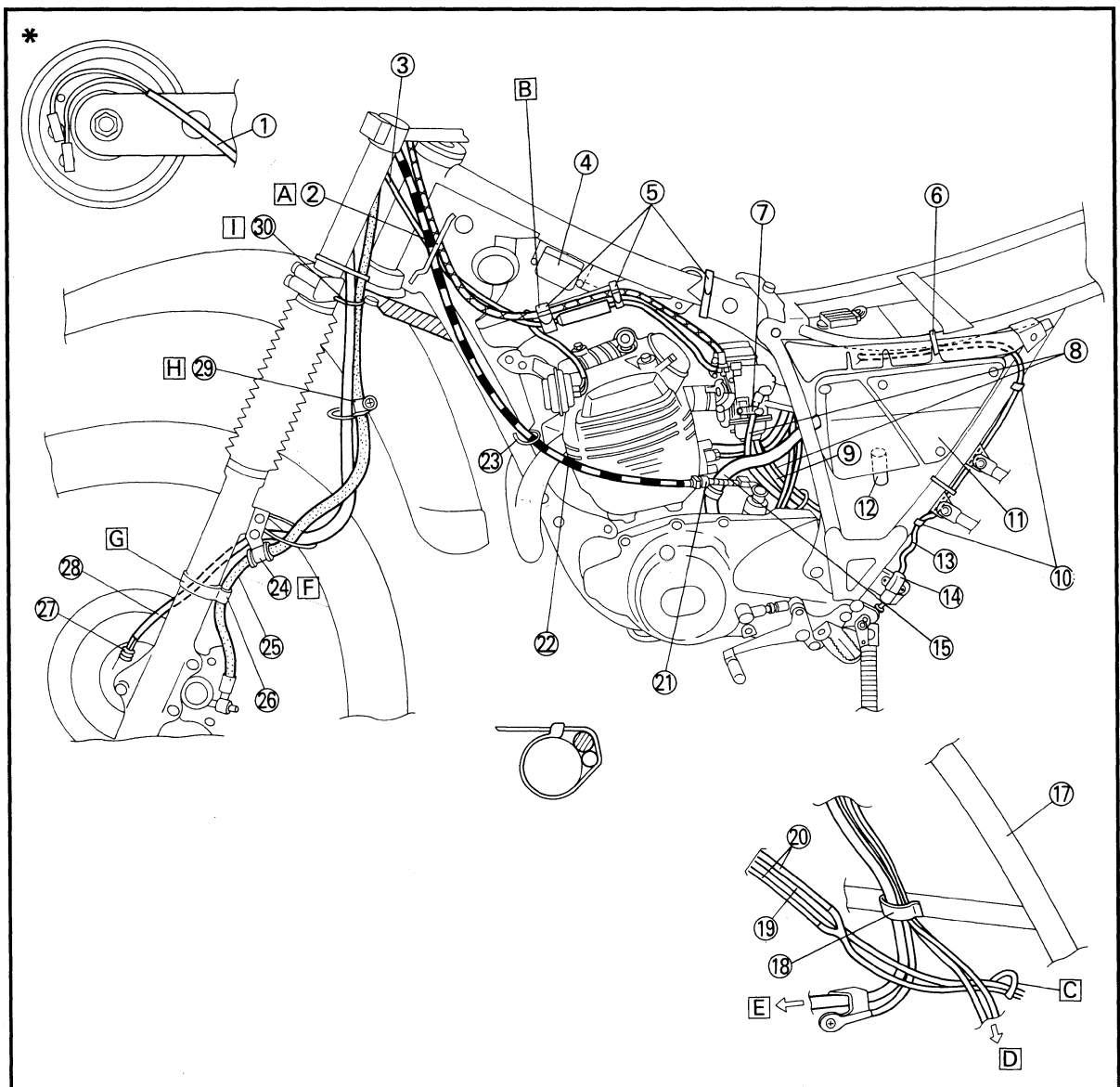

# CABLE ROUTING

**SPEC**



- |                                       |   |   |
|---------------------------------------|---|---|
| ① Band                                | ⑱ Guide   | Ⓔ Pass the overflow pipe, and air vent pipe through the guide and between the relay arm and swingarm. |
| ② Flasher relay                       | ⑳ Carburetor overflow pipe  | Ⓕ Band the battery lead together.   |
| ③ Starting circuit cut-off relay      | ㉑ Air vent pipe   | Ⓖ After connecting the couplers, put them inside of the leads.  |
| ④ CDI unit                            | ㉒ Fuse  | Ⓗ To starter motor.   |
| ⑤ CDI unit lead                       | ㉓ Battery   | Ⓘ To engine earth.  |
| ⑥ White tape                          | ㉔ Battery lead (+)  |   |
| ⑦ Carburetor                          | ㉕ Battery lead (-)  |   |
| ⑧ Canister hose (for California only) | ㉖ Starter relay   |   |
| ⑨ Band                                | ㉗ Taillight lead  |   |
| ⑩ Ignition coil                       | ㉘ Flasher light lead  |   |
| ⑪ Wireharness                         | ㉙ Wireharness   |   |
| ⑫ Horn lead                           | Ⓐ Do not band.  |   |
| ⑬ Canister (for California only)      | Ⓑ Tighten the rear brake switch lead, battery lead (-) and fly-wheel magneto leads (two). |   |
| ⑭ Band                                | Ⓒ Install the terminal with the lead facing downward.                                     |   |
| ⑮ Clamp                               | Ⓓ Tighten the battery lead (-) together.  |   |
| ⑯ Clamp                               |   |   |
| ⑰ Rear brake switch lead              |   |   |
| ⑱ Rear brake switch                   |   |   |

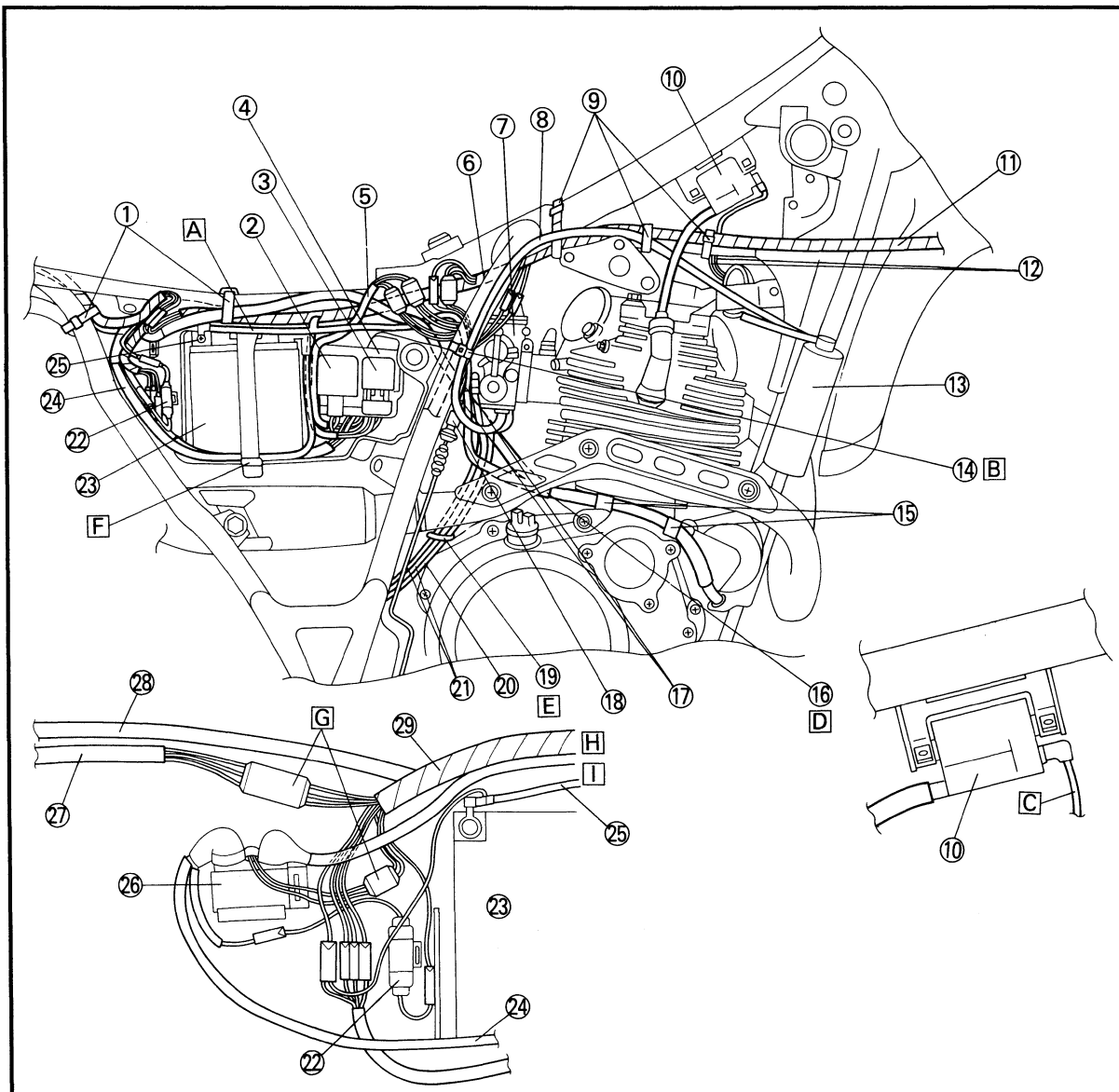

# CABLE ROUTING

SPEC



- ① Rectifier/regulator
- ② Band
- ③ Clamp
- ④ Rear flasher light lead (right)
- ⑤ Clamp
- ⑥ Taillight lead
- ⑦ Rear flasher light lead (left)
- ⑧ Band
- ⑨ Neutral relay

**A** Align the white tape on the wireharness with the seat pillar L.

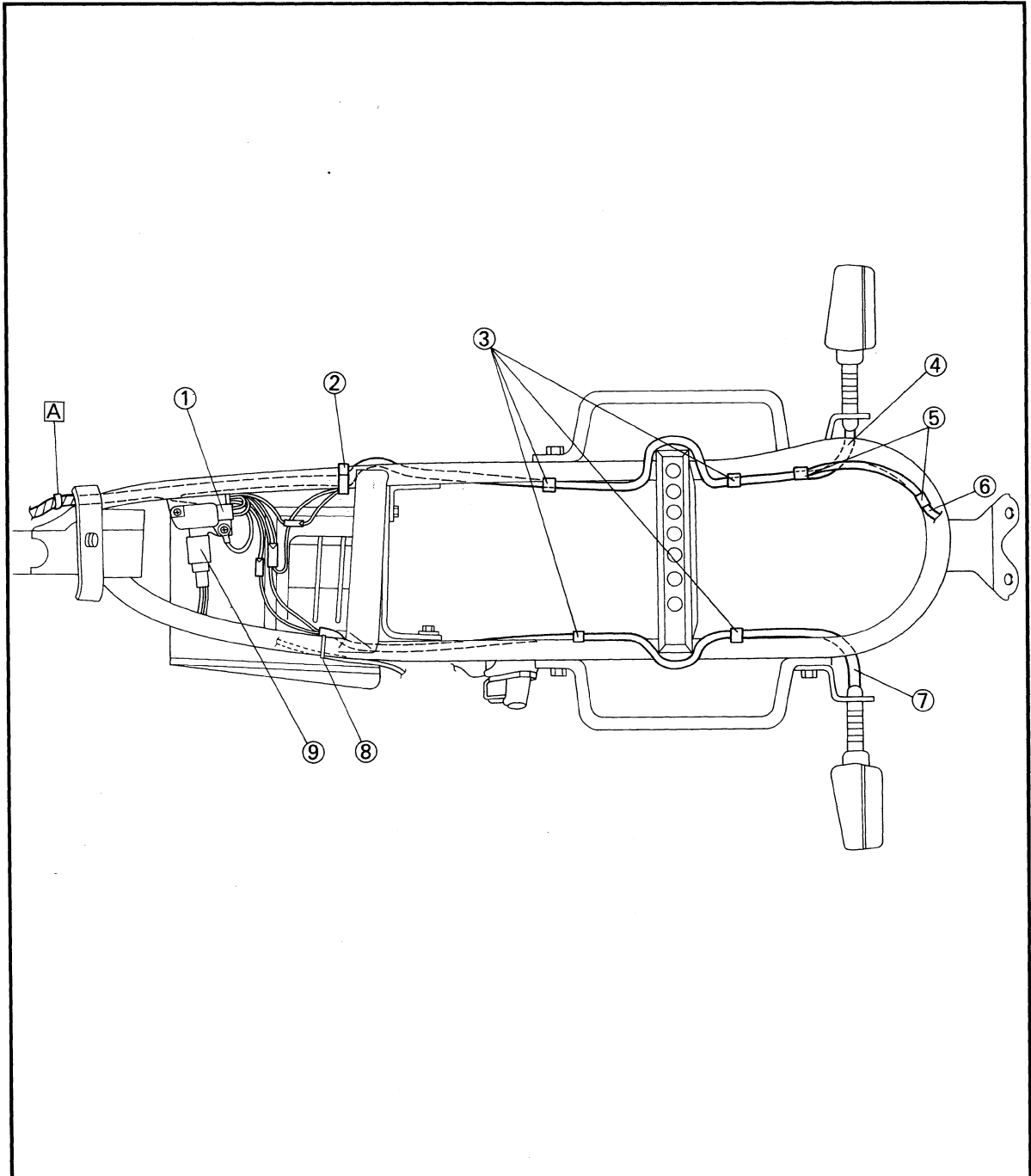



## ENGINE ENGINE ASSEMBLY AND ADJUSTMENT CLUTCH AND OIL PUMP

- ① Clutch spring
- ② Pressure plate
- ③ Push plate
- ④ O-ring
- ⑤ Push rod 1
- ⑥ Friction plate (type A)
- ⑦ Cushion spring
- ⑧ Clutch plate
- ⑨ Friction plate (type B)
- ⑩ Thrust washer
- ⑪ Clutch boss
- ⑫ Primary driven gear
- ⑬ Ball
- ⑭ Push rod 2
- ⑮ Push lever
- ⑯ Primary drive gear
- ⑰ Oil pump gear cover
- ⑱ Oil pump driven gear
- ⑲ Oil pump
- ⑳ Gasket

A FRICTION PLATE:		
Type	Thickness	Wear Limit
A 1 pc.	2.90~3.10 mm (0.114~0.122 in)	2.8 mm (0.110 in)
B 5 pcs.	2.90~3.10 mm (0.114~0.122 in)	2.8 mm (0.110 in)

B CLUTCH SPRING MINIMUM  
FREE LENGTH:  
35.3 mm (1.39 in)

C CLUTCH PLATE  
WARPAGE LIMIT:  
0.2 mm (0.008 in)

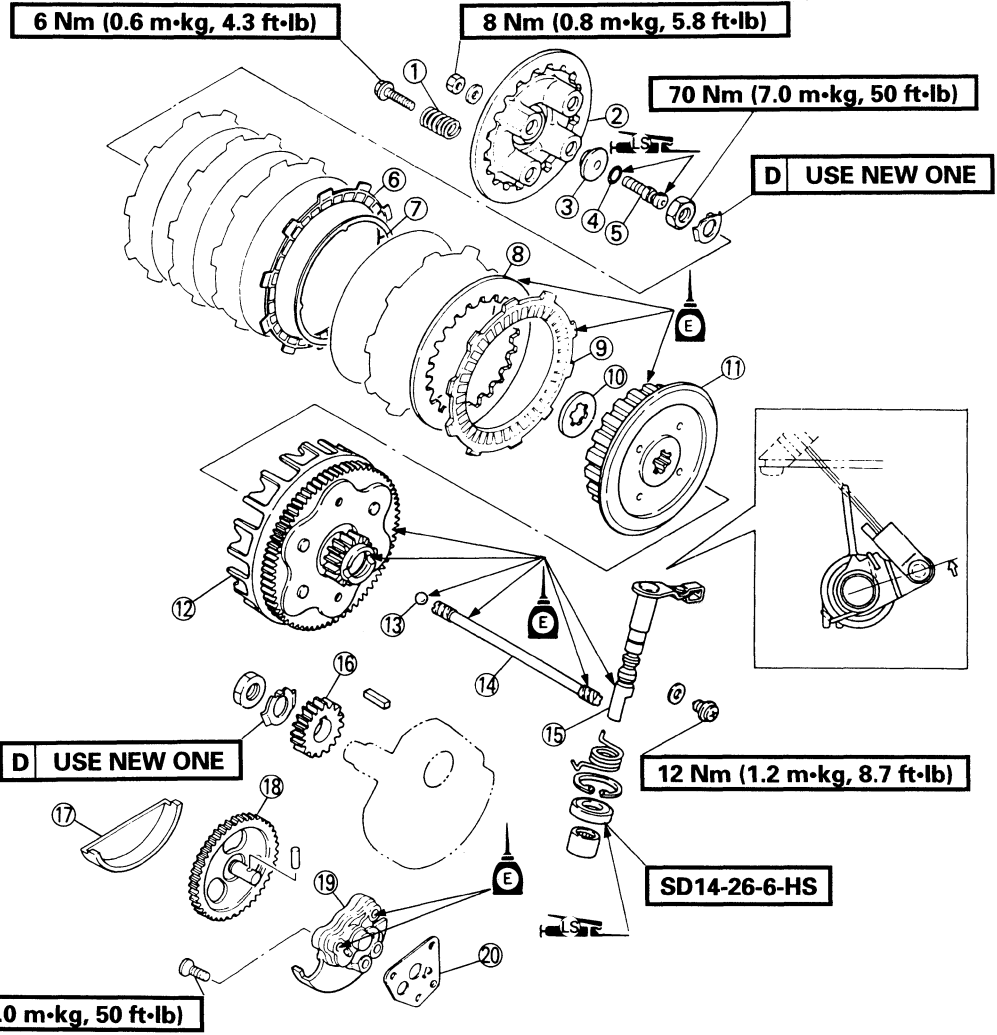



CHASSIS

FRONT FORK

- |                      |                   |                         |
|----------------------|-------------------|-------------------------|
| ① Clamp (fork boot)  | ⑧ Fork spring     | ⑮ Dust seal             |
| ② Fork boot          | ⑨ Piston ring     | ⑯ Oil seal stopper ring |
| ③ Front fork (right) | ⑩ Damper rod      | ⑰ Oil seal              |
| ④ Fork cap           | ⑪ Rebound spring  | ⑱ Seal spacer           |
| ⑤ Stopper ring       | ⑫ Inner fork tube | ⑲ Guide bush            |
| ⑥ Spring seat        | ⑬ Piston metal    | ⑳ Outer fork tube       |
| ⑦ O-ring             | ⑭ Oil lock piece  | ㉑ Front fork (left)     |

**FORK OIL (EACH):**  
**CAPACITY:**  
**A 366 cm<sup>3</sup> (12.9 Imp oz, 12.4 US oz)**  
**GRADE:**  
**FORK OIL 10W OR EQUIVALENT**

**FORK SPRING:**  
**MINIMUM FREE**  
**B LENGTH:**  
**588.8 mm (23.18 in)**

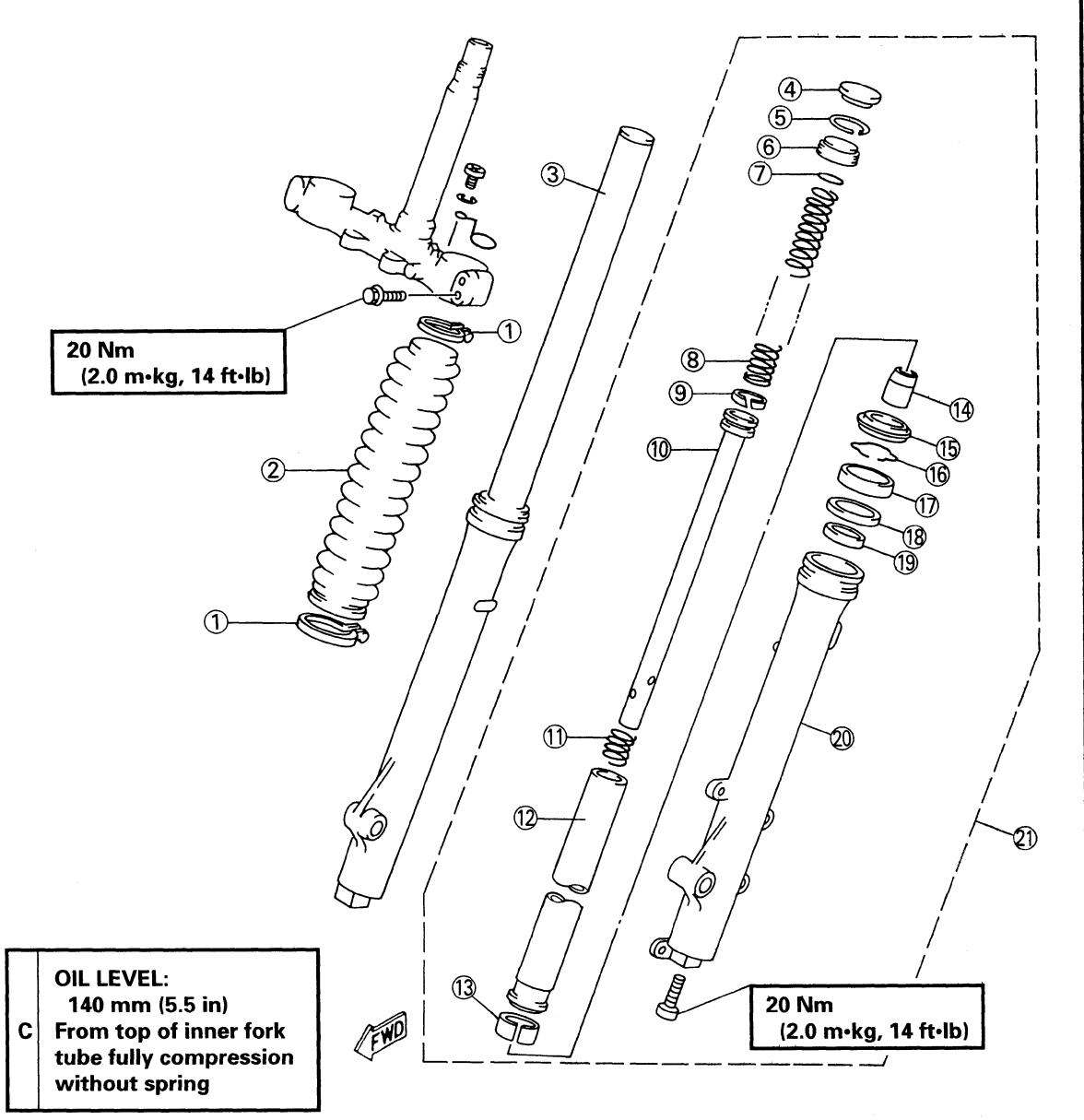

**OIL LEVEL:**  
**140 mm (5.5 in)**  
**C From top of inner fork tube fully compression without spring**