

YAMAHA

XJ900S(G) '95

SERVICE MANUAL



4KM-28197-20

NOTICE

This manual was written by the Yamaha Motor Company primarily for use by Yamaha dealers and their qualified mechanics. It is not possible to put an entire mechanic's education into one manual, so it is assumed that persons using this book to perform maintenance and repairs on Yamaha motorcycles have a basic understanding of the mechanical concepts and procedures inherent in motorcycle repair technology. Without such knowledge, attempted repairs or service to this model may render it unfit to use and/or unsafe.

Yamaha Motor Company, Ltd. is continually striving to improve all models manufactured by Yamaha. Modifications and significant changes in specifications or procedures will be forwarded to all Authorized Yamaha dealers and will, where applicable, appear in future editions of this manual.

PARTICULARLY IMPORTANT INFORMATION

This material is distinguished by the following notation.



The Safety Alert Symbol means ATTENTION! BECOME ALERT! YOUR SAFETY IS INVOLVED!

WARNING

Failure to follow WARNING instructions could result in severe injury or death to the motorcycle operator, a bystander, or a person inspecting or repairing the motorcycle.

CAUTION:

A CAUTION indicates special precautions that must be taken to avoid damage to the motorcycle.

NOTE:

A NOTE provides key information to make procedures easier or clearer.

HOW TO USE THIS MANUAL

CONSTRUCTION OF THIS MANUAL

This manual consists of chapters for the main categories of subjects. (See "Illustrated symbols")

- 1st title ①: This is a chapter with its symbol on the upper right of each page.
- 2nd title ②: This title appears on the upper of each page on the left of the chapter symbol. (For the chapter "Periodic inspection and adjustment" the 3rd title appears.)
- 3rd title ③: This is a final title.

MANUAL FORMAT

All of the procedures in this manual are organized in a sequential, step-by-step format. The information has been compiled to provide the mechanic with an easy to read, handy reference that contains comprehensive explanations of all disassembly, repair, assembly, and inspections.

A set of particularly important procedure ④ is placed between a line of asterisks "*" with each procedure preceded by "●".









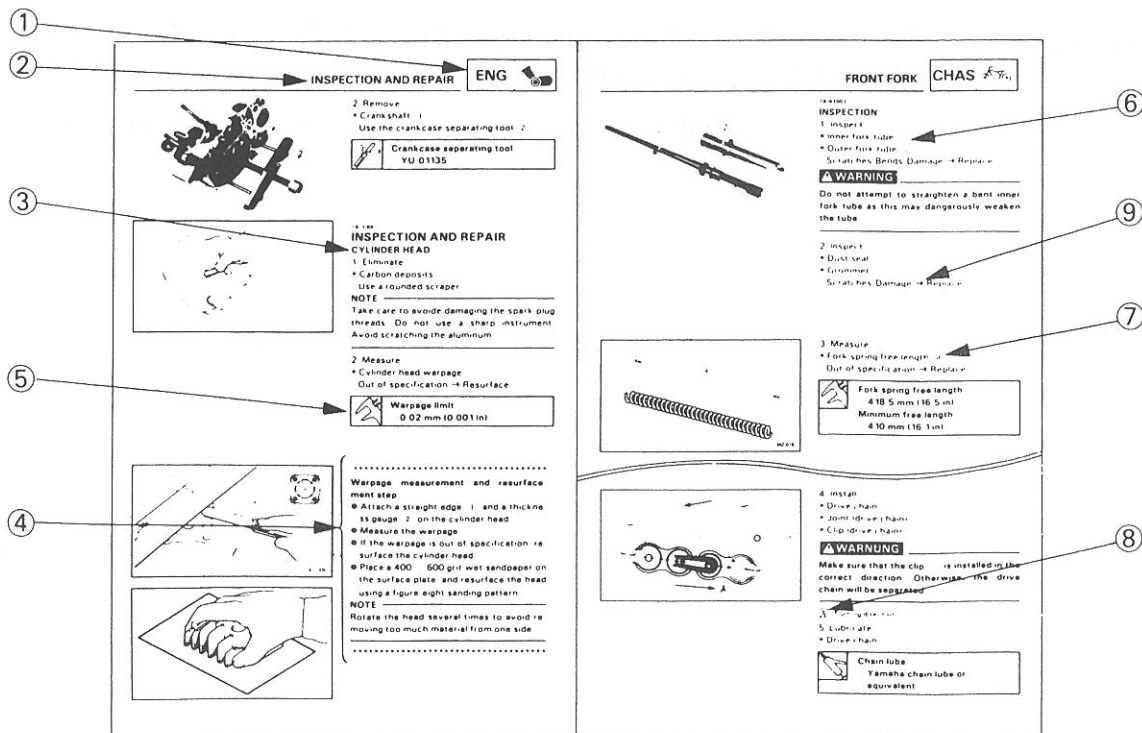







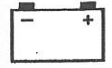

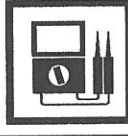

IMPORTANT FEATURES

- Data and a special tool are framed in a box preceded by a relevant symbol ⑤.
- An encircled numeral ⑥ indicates a part name, and an encircled alphabetical letter data or an alignment mark ⑦, the others being indicated by an alphabetical letter in a box ⑧.
- A condition of a faulty component will precede an arrow symbol and the course of action required the symbol ⑨.

EXPLODED DIAGRAM

Each chapter provides exploded diagrams before each disassembly section for ease in identifying correct disassembly and assembly procedures.



① GEN INFO 	② SPEC 	
③ INSP ADJ 	④ ENG 	
⑤ COOL 	⑥ CARB 	
⑦ CHAS 	⑧ ELEC 	
⑨ TRBL SHTG ?	⑩ 	
⑪ 	⑫ 	
⑬ 	⑭ 	
⑮ 	⑯ 	
⑰ 	⑱ 	⑲ 
⑳ 	㉑ 	㉒ 
㉓ 	㉔ New	

ILLUSTRATED SYMBOLS

(Refer to the illustration)

Illustrated symbols ① to ⑨ are designed as thumb tabs to indicate the chapter's number and content.

- ① General information
- ② Specifications
- ③ Periodic inspection and adjustment
- ④ Engine
- ⑤ Cooling system
- ⑥ Carburetion
- ⑦ Chassis
- ⑧ Electrical
- ⑨ Troubleshooting







Illustrated symbols ⑩ to ⑯ are used to identify the specifications appearing in the text.

- ⑩ Filling fluid
- ⑪ Lubricant
- ⑫ Special tool
- ⑬ Tightening
- ⑭ Wear limit, clearance
- ⑮ Engine speed
- ⑯ Ω, V, A

Illustrated symbols ⑰ to ㉔ in the exploded diagram indicate grade of lubricant and location of lubrication point.

- ⑰ Apply engine oil
- ⑱ Apply gear oil
- ⑲ Apply molybdenum disulfide oil
- ⑳ Apply wheel bearing grease
- ㉑ Apply lightweight lithium-soap base grease
- ㉒ Apply molybdenum disulfide grease
- ㉓ Apply locking agent (LOCTITE[®])
- ㉔ Use new one

INDEX

GENERAL INFORMATION	
	GEN INFO 1
SPECIFICATIONS	
	SPEC 2
PERIODIC INSPECTION AND ADJUSTMENT	
	INSP ADJ 3
ENGINE OVERHAUL	
	ENG 4
CARBURETION	
	CARB 5
CHASSIS	
	CHAS 6
ELECTRICAL	
	ELEC 7
TROUBLESHOOTING	?
	TRBL SHTG 8

CONTENTS

CHAPTER 1. GENERAL INFORMATION

MOTORCYCLE IDENTIFICATION	1-1
VEHICLE IDENTIFICATION NUMBER (For E, AUS and NZ)	1-1
FRAME SERIAL NUMBER (Except for E, AUS and NZ)	1-1
ENGINE SERIAL NUMBER	1-1
IMPORTANT INFORMATION	1-2
PREPARATION FOR REMOVAL	1-2
ALL REPLACEMENT PARTS	1-2
GASKETS, OIL SEALS, AND O-RINGS	1-2
LOCK WASHERS/PLATES AND COTTER PINS	1-3
BEARINGS AND OIL SEALS	1-3
CIRCLIPS	1-3
SPECIAL TOOLS	1-4
FOR TUNE UP	1-4
FOR ENGINE SERVICE	1-5
FOR CHASSIS SERVICE	1-6
FOR ELECTRICAL COMPONENTS	1-7

CHAPTER 2. SPECIFICATIONS

GENERAL SPECIFICATIONS	2-1
MAINTENANCE SPECIFICATIONS	2-4
ENGINE	2-4
CHASSIS	2-13
ELECTRICAL	2-17
EXCLUSIVE SPECIFICATION	2-20
HOW TO USE THE CONVERSION TABLE	2-21
GENERAL TORQUE SPECIFICATIONS	2-21
LUBRICATION POINT AND GRADE OF LUBRICANT	2-22
ENGINE	2-22
CHASSIS	2-23

LUBRICATION DIAGRAMS 2-24

CABLE ROUTING 2-28

CHAPTER 3. PERIODIC INSPECTION AND ADJUSTMENT

INTRODUCTION 3-1

PERIODIC MAINTENANCE/LUBRICATION INTERVALS 3-1

SIDE COVER, FUEL TANK AND COWLING 3-3

REMOVAL 3-3

INSTALLATION 3-5

ENGINE 3-6

VALVE CLEARANCE ADJUSTMENT 3-6

CARBURETOR SYNCHRONIZATION 3-13

IDLING SPEED ADJUSTMENT 3-15

THROTTLE CABLE ADJUSTMENT 3-16

SPARK PLUG INSPECTION 3-18

IGNITION TIMING CHECK 3-19

COMPRESSION PRESSURE MEASUREMENT 3-20

ENGINE OIL LEVEL INSPECTION 3-22

ENGINE OIL REPLACEMENT 3-23

CLUTCH ADJUSTMENT 3-25

AIR FILTER CLEANING 3-26

FUEL LINE INSPECTION 3-27

CHASSIS 3-28

FRONT BRAKE LEVER POSITION ADJUSTMENT 3-28

REAR BRAKE ADJUSTMENT 3-28

BRAKE FLUID LEVEL INSPECTION 3-30

BRAKE PAD INSPECTION 3-31

BRAKE LIGHT SWITCH ADJUSTMENT 3-31

BRAKE HOSE INSPECTION 3-32

AIR BLEEDING (HYDRAULIC BRAKE SYSTEM) 3-33

FINAL GEAR OIL LEVEL INSPECTION 3-34

FINAL GEAR OIL REPLACEMENT 3-35

STEERING HEAD INSPECTION 3-35

FRONT FORK INSPECTION 3-38

REAR SHOCK ABSORBER ADJUSTMENT 3-38



GEN
INFO 1



SPEC 2



INSP
ADJ 3



ENG 4



CARB 5



CHAS 6



ELEC 7



TRBL
SHTG 8

TIRE INSPECTION	3-39
WHEEL INSPECTION	3-42
CABLE INSPECTION AND LUBRICATION	3-42
LEVER AND PEDAL LUBRICATION	3-43
SIDESTAND LUBRICATION	3-43
CENTERSTAND LUBRICATION	3-43
REAR SUSPENSION LUBRICATION	3-43
ELECTRICAL	3-44
BATTERY INSPECTION	3-44
FUSE INSPECTION	3-50
HEADLIGHT BEAM ADJUSTMENT	3-52
HEADLIGHT BULB REPLACEMENT	3-52
DIGITAL CLOCK ADJUSTMENT	3-53

CHAPTER 4. ENGINE OVERHAUL

ENGINE REMOVAL	4-1
FUEL TANK AND COWLINGS	4-1
ENGINE OIL	4-1
BATTERY LEADS	4-1
AIR FILTER CASE	4-2
A.I.S (AIR INDUCTION SYSTEM)	4-2
CARBURETOR	4-2
HOSES AND LEADS	4-2
CLUTCH CABLE	4-3
SHIFT PEDAL	4-3
STARTER MOTOR	4-3
A.C. GENERATOR	4-4
EXHAUST PIPE	4-4
OIL COOLER	4-4
DRIVE SHAFT RUBBER BOOT	4-5
ENGINE REMOVAL	4-5
ENGINE DISASSEMBLY	4-6
CYLINDER HEAD COVER, CAMSHAFT AND CYLINDER HEAD	4-6
CYLINDER AND PISTON	4-8
PICKUP COIL	4-10
CLUTCH	4-10
OIL PAN AND OIL PUMP	4-11
SHIFT SHAFT	4-12
MIDDLE GEAR	4-13
CRANKCASE DISASSEMBLY	4-13
SHIFT FORK AND SHIFT CAM	4-14
TRANSMISSION	4-15

CRANKSHAFT AND STARTER CLUTCH	4-15
VALVE	4-16
CONNECTING ROD.....	4-18
OIL PUMP	4-18
INSPECTION AND REPAIR.....	4-19
CYLINDER HEAD.....	4-19
VALVE AND VALVE GUIDE	4-20
VALVE SEAT.....	4-22
VALVE SPRING	4-25
VALVE LIFTER	4-26
CAMSHAFT	4-26
TIMING CHAIN, SPROCKET AND CHAIN GUIDE	4-27
TIMING CHAIN TENSIONER	4-28
CYLINDER AND PISTON	4-28
PISTON RING	4-30
PISTON PIN	4-31
CRANKSHAFT AND CONNECTING ROD	4-31
OIL PUMP	4-36
PRIMARY DRIVE.....	4-37
STARTER DRIVES	4-37
CLUTCH	4-38
TRANSMISSION AND SHIFTER.....	4-40
SHIFT SHAFT AND STOPPER LEVER	4-42
OIL-JET NOZZLE	4-42
RELIEF VALVE, OIL PIPE AND STRAINER.....	4-42
OIL COOLER	4-43
CRANKCASE	4-43
BEARING AND OIL SEAL	4-43
CIRCLIP AND WASHER	4-43
MIDDLE GEAR SERVICE.....	4-44
REMOVAL.....	4-45
DISASSEMBLY	4-45
INSPECTION.....	4-47
REASSEMBLY	4-47
INSTALLATION	4-49
GEAR LASH MEASUREMENT	4-49
GEAR LASH ADJUSTMENT	4-50
MIDDLE DRIVE GEAR AND DRIVEN GEAR POSITIONING	4-52
ENGINE ASSEMBLY AND ADJUSTMENT.....	4-54
OIL PUMP	4-54
CONNECTING ROD.....	4-56
VALVE	4-57
CRANKSHAFT AND STARTER CLUTCH	4-58
TRANSMISSION	4-60
SHIFT FORK AND SHIFT CAM	4-61

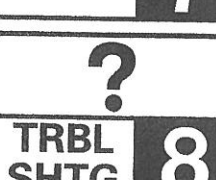
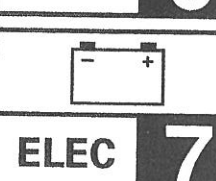
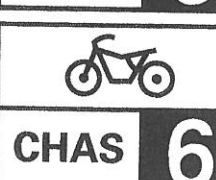
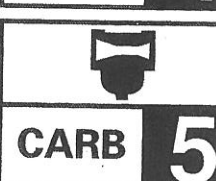
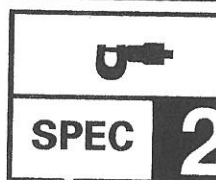
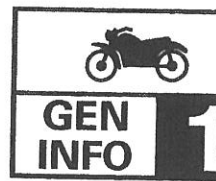

CRANKCASE ASSEMBLY.....	4-61
MIDDLE GEAR SHAFT	4-64
SHIFT SHAFT.....	4-64
OIL PAN AND OIL PUMP.....	4-65
CLUTCH AND PICKUP COIL.....	4-67
PISTON AND CYLINDER	4-70
CYLINDER HEAD AND CAMSHAFT.....	4-72
TIMING CHAIN TENSIONER	4-77
CYLINDER HEAD COVER.....	4-78
ENGINE REMOUNTING.....	4-78

CHAPTER 5. CARBURETION

CARBURETOR.....	5-1
REMOVAL.....	5-2
DISASSEMBLY.....	5-2
INSPECTION.....	5-5
ASSEMBLY.....	5-7
INSTALLATION	5-9
FUEL LEVEL ADJUSTMENT.....	5-9
TPS (THROTTLE POSITION SENSOR) ADJUSTMENT AND INSPECTION	5-10
 A.I.S. (AIR INDUCTION SYSTEM).....	 5-12
AIR INJECTION	5-12
AIR CUT VALVE.....	5-12
A.I.S. (AIR INDUCTION SYSTEM) DIAGRAMS	5-13
A.I.S. (AIR INDUCTION SYSTEM) INSPECTION	5-14
A.I.S. (AIR INDUCTION SYSTEM) ADJUSTMENT.....	5-15









CHAPTER 6. CHASSIS

FRONT WHEEL.....	6-1
REMOVAL.....	6-2
INSPECTION.....	6-3
INSTALLATION	6-4
STATIC WHEEL BALANCE ADJUSTMENT	6-5
 REAR WHEEL	 6-7
REMOVAL.....	6-8
INSPECTION.....	6-9
INSTALLATION	6-9
STATIC WHEEL BALANCE ADJUSTMENT	6-10

FRONT AND REAR BRAKE	6-11
BRAKE PAD REPLACEMENT.....	6-13
CALIPER DISASSEMBLY.....	6-17
MASTER CYLINDER DISASSEMBLY.....	6-20
INSPECTION AND REPAIR.....	6-22
CALIPER ASSEMBLY.....	6-25
MASTER CYLINDER ASSEMBLY.....	6-30
FRONT FORK	6-35
REMOVAL.....	6-36
DISASSEMBLY.....	6-37
INSPECTION.....	6-38
ASSEMBLY.....	6-39
INSTALLATION.....	6-42
STEERING HEAD AND HANDLEBAR	6-43
REMOVAL.....	6-44
INSPECTION.....	6-46
INSTALLATION.....	6-47
REAR SHOCK ABSORBER AND SWINGARM	6-52
HANDLING NOTES.....	6-53
NOTES ON DISPOSAL.....	6-53
REMOVAL.....	6-53
INSPECTION.....	6-57
INSTALLATION.....	6-58
SHAFT DRIVE	6-61
TROUBLESHOOTING.....	6-62
REMOVAL.....	6-66
FINAL DRIVE GEAR CASE.....	6-66
DRIVE SHAFT.....	6-76
INSTALLATION.....	6-76

CHAPTER 7. ELECTRICAL

ELECTRICAL COMPONENTS	7-1
CHECKING OF CONNECTIONS	7-3
IGNITION SYSTEM	7-4
CIRCUIT DIAGRAM.....	7-4
TROUBLESHOOTING.....	7-5

	GEN INFO	1
	SPEC	2
	INSP ADJ	3
	ENG	4
	CARB	5
	CHAS	6
	ELEC	7
	TRBL SHTG	8









ELECTRIC STARTING SYSTEM	7-11
CIRCUIT DIAGRAM	7-11
STARTING CIRCUIT OPERATION	7-12
TROUBLESHOOTING	7-13
STARTER MOTOR.....	7-19
CHARGING SYSTEM	7-24
CIRCUIT DIAGRAM	7-24
TROUBLESHOOTING	7-25
LIGHTING SYSTEM	7-29
CIRCUIT DIAGRAM	7-29
TROUBLESHOOTING	7-30
LIGHTING SYSTEM CHECK	7-33
SIGNAL SYSTEM	7-37
CIRCUIT DIAGRAM	7-37
TROUBLESHOOTING	7-39
SIGNAL SYSTEM CHECK	7-41
FUEL PUMP SYSTEM	7-53
CIRCUIT DIAGRAM	7-53
FUEL PUMP CIRCUIT OPERATION	7-54
TROUBLESHOOTING	7-55
FUEL PUMP TEST	7-58
CARBURETOR HEATER SYSTEM	7-59
CIRCUIT DIAGRAM	7-59
TROUBLESHOOTING	7-60
TPS (THROTTLE POSITION SENSOR) SELF DIAGNOSIS	7-64
CIRCUIT DIAGRAM	7-64
TROUBLESHOOTING	7-65

CHAPTER 8. TROUBLESHOOTING

STARTING FAILURE/HARD STARTING	8-1
FUEL SYSTEM.....	8-1
ELECTRICAL SYSTEM	8-1
COMPRESSION SYSTEM.....	8-2
POOR IDLE SPEED PERFORMANCE	8-2
POOR IDLE SPEED PERFORMANCE.....	8-2

POOR MEDIUM AND HIGH SPEED PERFORMANCE	8-2
POOR MEDIUM AND HIGH SPEED PERFORMANCE	8-2
FAULTY GEAR SHIFTING	8-3
HARD SHIFTING	8-3
SHIFT PEDAL DOES NOT MOVE	8-3
JUMP-OUT GEAR	8-3
CLUTCH SLIPPING/Dragging	8-3
CLUTCH SLIPPING	8-3
CLUTCH DRAGGING	8-3
OVERHEATING	8-4
OVERHEATING	8-4
FAULTY BRAKE	8-4
POOR BRAKING EFFECT	8-4
FRONT FORK OIL LEAKAGE AND FRONT FORK MALFUNCTION	8-4
OIL LEAKAGE	8-4
MALFUNCTION	8-4
INSTABLE HANDLING	8-4
INSTABLE HANDLING	8-4
FAULTY LIGHTING AND SIGNAL SYSTEM	8-5
HEADLIGHT DARK	8-5
BULB BURNT OUT	8-5
FLASHER DOES NOT LIGHT	8-5
FLASHER WINKS SLOWER	8-5
FLASHER KEEPS ON	8-5
FLASHER WINKS QUICKER	8-5
HORN IS INOPERATIVE	8-5

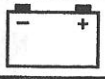
XJ900S(G) '95 WIRING DIAGRAM

	GEN INFO	1
	SPEC	2
	INSP ADJ	3
	ENG	4
	CARB	5
	CHAS	6
	ELEC	7
	TRBL SHTG	8



1

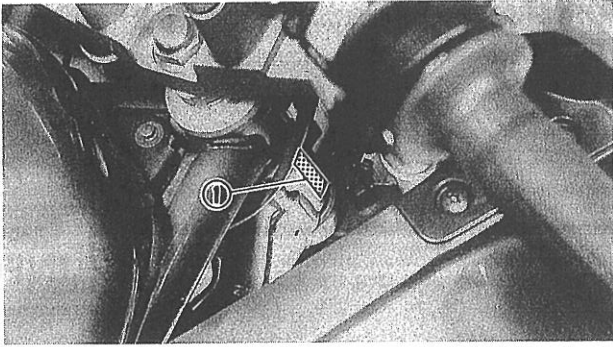

GENERAL INFORMATION
MOTORCYCLE IDENTIFICATION

VEHICLE IDENTIFICATION NUMBER

(For E, AUS and NZ)

The vehicle identification number ① is stamped into the right side of the steering head.

Starting serial number:
JYA4KMS0*SA023101 (E)
JYA4PST0*SA000101 (AUS, NZ)

NOTE:

The vehicle identification number is used to identify your motorcycle and may be used to register your motorcycle with the licensing authority in your state.

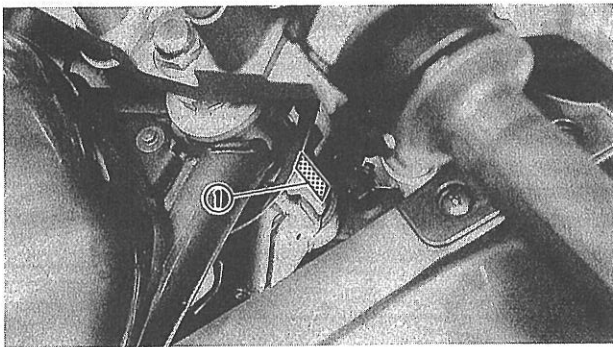

FRAME SERIAL NUMBER

(Except for E, AUS and NZ)

The frame serial number ① is stamped into the right side of the steering head.

Starting serial number:
4KM-000101
4PR-000101 (CH, A)

NOTE:

The first three digits of these numbers are for model identifications; the remaining digits are the unit production number.

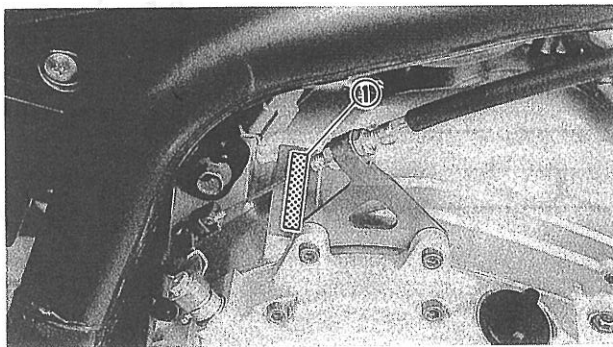

ENGINE SERIAL NUMBER

The engine serial number ① is stamped into crankcase.

Starting serial number:
4KM-000101
4KM-023101 (E)
4PR-000101 (CH, A)
4PS-000101 (AUS, NZ)

NOTE:

- The first three digits of these numbers are for model identification; the remaining digits are the unit production number.
- Designs and specifications are subject to change without notice.

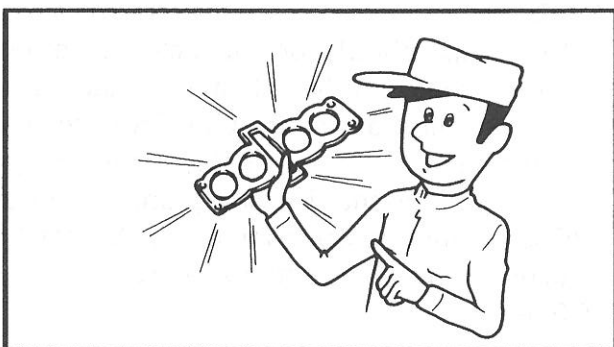
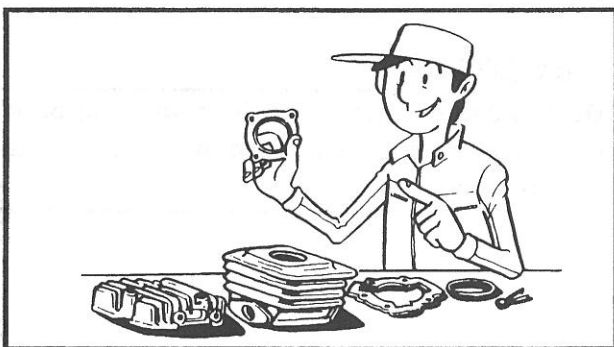
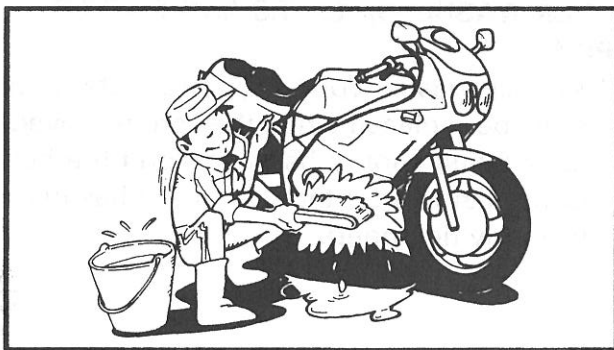

IMPORTANT INFORMATION

PREPARATION FOR REMOVAL

1. Remove all dirt, mud dust, and foreign material before removal and disassembly.
2. Use proper tools and cleaning equipment. Refer to "SPECIAL TOOLS".
3. When disassembling the machine keep mated parts together. This includes gears, cylinders, pistons, and other mated parts that have been "mated" through normal wear. Mated parts must be reused as an assembly or replaced.
4. During the machine disassembly, clean all parts and place them in trays in the order of disassembly. This will speed up assembly time and help assure that all parts are correctly reinstalled.
5. Keep away from fire.

ALL REPLACEMENT PARTS

1. Use only genuine Yamaha parts for all replacements. Use oil and/or grease recommended by Yamaha for assembly and adjustment. Other brands may be similar in function and appearance, but inferior in quality.

GASKETS, OIL SEALS, AND O-RINGS

1. All gaskets, seals and O-rings should be replaced when an engine is overhauled. All gaskets surfaces, oil seal lips and O-rings must be cleaned.
2. Properly oil all mating parts and bearing during reassembly. Apply grease to the oil seal lips.

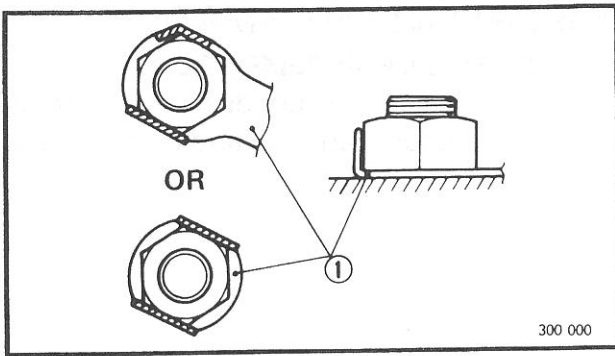

LOCK WASHERS/PLATES AND COTTER PINS

1. All lock washers/plates ① and cotter pins must be replaced when they are removed. Lock tab(s) should be bent along the bolt or nut flat(s) after the bolt or nut has been properly tightened.

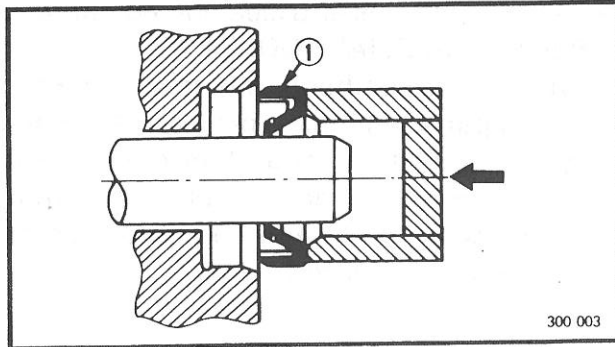

BEARINGS AND OIL SEALS

1. Install the bearing(s) and oil seal(s) with their manufacturer's marks or numbers facing outward. (In other words, the stamped letters must be on the side exposed to view.) When installing oil seal(s), apply a light coating of light-weight lithium base grease to the seal lip(s). Oil the bearings liberally when installing.

① Oil seal

CAUTION:

Do not use compressed air to spin the bearings dry. This causes damage to the bearing surfaces.

① Bearing

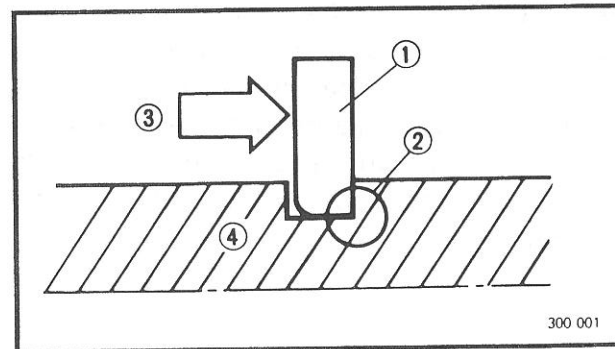
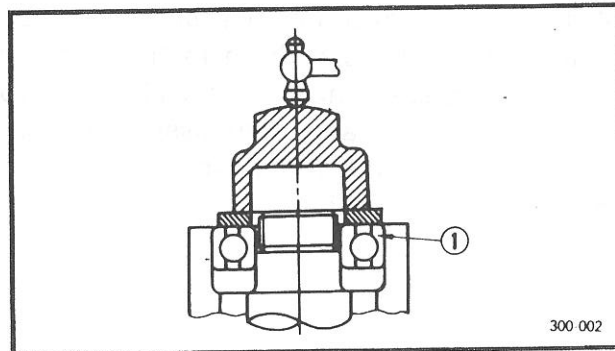

CIRCLIPS

1. All circlips should be inspected carefully before reassembly. Always replace piston pin clips after one use. Replace distorted circlips. When installing a circlip ①, make sure that the sharp edged corner ② is positioned opposite to the thrust ③ it receives. See the sectional view.

④ Shaft

SPECIAL TOOLS

The proper special tools are necessary for complete and accurate tune-up and assembly. Using the correct special tool will help prevent damage caused by the use of improper tools or improvised techniques. The shape and part number used for the special tool differ by country, so two types are provided.

Refer to the list provided to avoid errors when placing an order.

FOR TUNE UP

2

Inductive timing light
P/N. 90890-03141

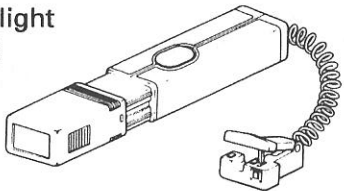

This tool is necessary for checking ignition timing.

4

Vacuum gauge
P/N. 90890-03094
Adapter
P/N. 90890-03060

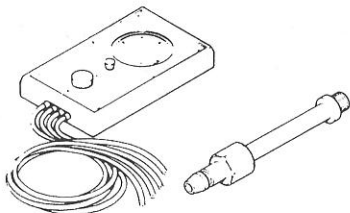

This gauge is needed for carburetor synchronization.

6

Carburetor angle driver
P/N. 90890-03158

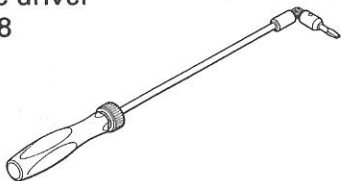

This tool is used to adjust the pilot screw.

1

Inductive tachometer
P/N. 90890-03113

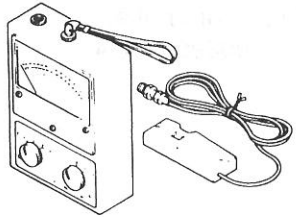

This tool is needed for detecting engine rpm.

3

Compression gauge
P/N. 90890-03081
Adapter
P/N. 90890-04082

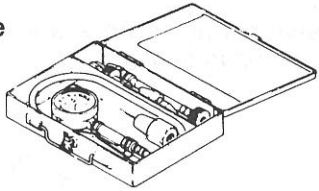

This gauge is used to measure the engine compression.

5

Fuel level gauge
P/N. 90890-01312

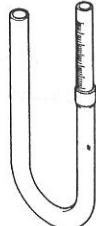

This gauge is used to measure the fuel level in the float chamber.

7

Exhaust attachment
P/N. 90890-03134

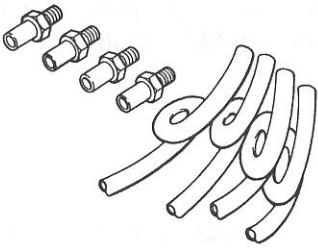

This tool is used to measure the exhaust gas.



FOR ENGINE SERVICE

1

Tappet adjusting tool
P/N. 90890-04125

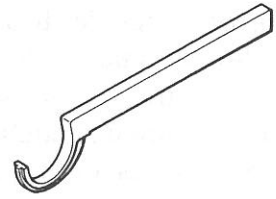

This tool is necessary to replace valve adjusting pads.

2

Piston pin puller
P/N. 90890-01304

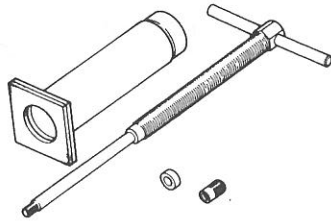

This tool is used to remove the piston pin.

3

Universal clutch holder
P/N. 90890-04086

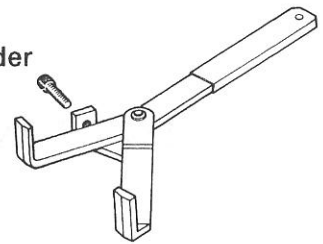

This tool is used to hold the clutch when removing or installing the clutch boss locknut.

4

Valve spring compressor
P/N. 90890-04019

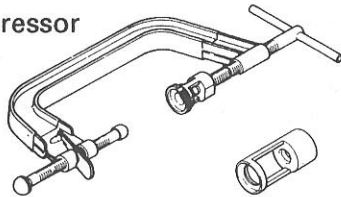

This tool is needed to remove and install the valve assemblies.

5

Attachment
P/N. 90890-01243



This tool is needed to remove and install the valve assemblies.

6

Valve guide remover (6.0 mm)
P/N. 90890-04064

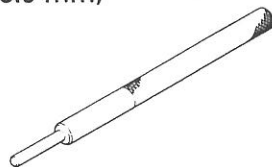

This tool is used to remove the valve guides.

7

Valve guide installer (6.0 mm)
P/N. 90890-04065



This tool is needed to install the valve guides properly.

8

Valve guide reamer (6.0 mm)
P/N. 90890-04066

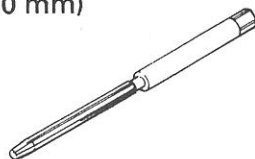

This tool is used to rebores the new valve guide.

9

Valve seat cutter
P/N. YM-91043-C

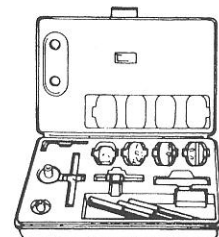

This tool is used to adjust the valve clearance.