

**YAMAHA**

# SJ700AU

## Service Manual

LIT-18616-01-43

---

## PREFACE

This manual has been prepared by the Yamaha Motor Company Ltd. primarily for use by Yamaha dealers and their trained mechanics when performing maintenance procedures and repairs to Yamaha equipment. It has been written to suit the needs of persons who have a basic understanding of the mechanical and electrical concepts and procedures inherent in the work, for without such knowledge attempted repairs or service to the equipment could render it unsafe or unfit for use.

Because the Yamaha Motor Company Ltd. has a policy of continuously improving its products, models may differ in detail from the descriptions and illustrations given in this publication. Use only the latest edition of this manual. Authorized Yamaha dealers are notified periodically of modifications and significant changes in specifications and procedures, and these are incorporated in successive editions of this manual.

A10001-0\*

**SJ700AU  
SERVICE MANUAL**

**©1996 by Yamaha Motor Co., Ltd.**

**1st Edition, January 1996**

**All rights reserved.**

**No part of this publication may be reproduced or transmitted in any form or by any means including photocopying and recording without the written permission of the copyright holder.**

**Such written permission must also be obtained before any part of this publication is stored in a retrieval system of any nature.**

**Printed in U.S.A.  
LIT-18616-01-43**

---

**WARNINGS, CAUTIONS AND NOTES**

Attention is drawn to the various Warnings, Cautions and Notes which distinguish important information in this manual in the following ways.

 The Safety Alert Symbol means ATTENTION! BECOME ALERT! YOUR SAFETY IS INVOLVED!

---

** WARNING**

Failure to follow **WARNING** instructions could result in severe injury or death to the machine operator, a bystander, or a person inspecting or repairing the water vehicle.

---

---

**CAUTION:**

A **CAUTION** indicates special precautions that must be taken to avoid damage to the water vehicle.

---

---

**NOTE:**

A **NOTE** provides key information to make procedures easier or clearer.

---

## HOW TO READ DESCRIPTIONS

1. A disassembly installation job mainly consists of the exploded diagram ①.
2. The numerical figures represented by the number ② indicates the order of the job steps.
3. The symbols represented by the number ③ indicates the contents and notes of the job.  
For the meanings of the symbols, refer to the next page(s).
4. The REMOVAL AND INSTALLATION CHART ④ is attached to the exploded diagram and explains the job steps, part names, notes for the jobs, etc.
5. The SERVICE POINTS, other than the exploded diagram, explains in detail the items difficult to explain in the exploded diagram or REMOVAL AND INSTALLATION CHART, the Service points requiring the detailed description ⑤, etc.

**JET PUMP**

**DEFLECTOR, NOZZLE AND DUCT**

**E**

**DEFLECTOR, NOZZLE AND DUCT  
EXPLODED DIAGRAM**

**④** → **REMOVAL AND INSTALLATION CHART**

Step	Procedure/Part name	Q'ty	Service points
<b>DEFLECTOR, NOZZLE AND DUCT REMOVAL</b>			Follow the left "Step" for removal.
Jet pump unit			Refer to "JET PUMP UNIT REMOVAL".
② 1	Nozzle deflector assembly	1	<div style="display: flex; justify-content: space-between;"> <span>⑤</span> <span>⑤</span> </div>
2	Bolt	4	
3	Housing	1	
4	Pin	2	
5	Impeller duct assembly	1	
6	Pin	1	
7	Nozzle	1	
			Reverse the removal steps for installation.

6-2

---

## HOW TO USE THIS MANUAL

### MANUAL FORMAT

All of the procedures in this manual are organized in a sequential, step-by-step format. The information has been compiled to provide the mechanic with an easy to read, handy reference that contains comprehensive explanations of all disassembly, repair, assembly, and inspection operations.

In this revised format, the condition of a faulty component will precede an arrow symbol and the course of action required will follow the symbol, e.g.,

- Bearings  
Pitting/Damage → Replace.

To assist you to find your way about this manual, the Section Title and Major Heading is given at the head of every page.

An Index to contents is provided on the first page of each Section.

### MODEL INDICATION

Multiple models are shown in this manual. These indications are noted as follows.

















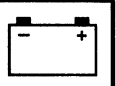





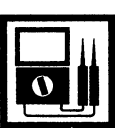

Model name	Super Jet
	SJ700A
Indication	SJ700A

### THE ILLUSTRATIONS

Some illustrations in this manual may differ from the model you have. This is because a procedure described may relate to several models, though only one may be illustrated. (The name of model described will be mentioned in the description).

### REFERENCES

These have been kept to a minimum; however, when you are referred to another section of the manual, you are told the page number to go to.

① <b>GEN INFO</b> 	② <b>SPEC</b> 
③ <b>INSP ADJ</b> 	④ <b>FUEL</b> 
⑤ <b>POWR</b> 	⑥ <b>JET PUMP</b> 
⑦ <b>ELEC</b> 	⑧ <b>HULL HOOD</b> 
⑨ <b>TRBL ANLS</b> 	⑩ 
⑪ 	⑫ 
⑬ 	⑭ 
⑮ 	⑯ 
⑰ 	⑱ 
⑲ 	⑳ 
㉑ 	㉒ 
㉓ 	㉔ 

### SYMBOLS

Symbols ① to ⑨ are designed as thumb-tabs to indicate the content of a chapter:

- ① General Information
- ② Specifications
- ③ Periodic Inspection and Adjustment
- ④ Fuel System
- ⑤ Power Unit
- ⑥ Jet pump Unit
- ⑦ Electrical System
- ⑧ Hull and Hood
- ⑨ Trouble-analysis

Symbols ⑩ to ⑮ indicate specific data:

- ⑩ Special tool
- ⑪ Specified liquid
- ⑫ Specified engine speed
- ⑬ Specified torque
- ⑭ Specified measurement
- ⑮ Specified electrical valve  
[Resistance ( $\Omega$ ), Voltage (V), Electric current (A)]

Symbol ⑯ to ⑱ in an exploded diagram indicate grade of lubricant and location of lubrication point:

- ⑯ Apply Yamaha 2-stroke outboard motor oil
- ⑰ Apply water resistant grease (Yamaha grease A, Yamaha marine grease)
- ⑱ Apply molybdenum disulfide grease









Symbols ⑲ to ㉔ in an exploded diagram indicate grade of sealing or locking agent, and location of application point:

- ⑲ Apply Gasket Maker<sup>®</sup>
- ⑳ Apply Yamahabond #4 (Yamaha bond No.4)
- ㉑ Apply LOCTITE<sup>®</sup> No. 271 (Red LOCTITE)
- ㉒ Apply LOCTITE<sup>®</sup> No. 242 (Blue LOCTITE)
- ㉓ Apply LOCTITE<sup>®</sup> No. 572
- ㉔ Apply Silicon sealant

### NOTE:

In this manual, the above symbols may not be used in every case.

# INDEX

<b>GENERAL INFORMATION</b>	 GEN INFO	<b>1</b>
<b>SPECIFICATIONS</b>	 SPEC	<b>2</b>
<b>PERIODIC INSPECTION AND ADJUSTMENT</b>	 INSP ADJ	<b>3</b>
<b>FUEL SYSTEM</b>	 FUEL	<b>4</b>
<b>POWER UNIT</b>	 POWR	<b>5</b>
<b>JET PUMP UNIT</b>	 JET PUMP	<b>6</b>
<b>ELECTRICAL SYSTEM</b>	 ELEC	<b>7</b>
<b>HULL AND HOOD</b>	 HULL HOOD	<b>8</b>
<b>TROUBLE-ANALYSIS</b>	 TRBL ANLS	<b>9</b>

**CHAPTER 1  
GENERAL INFORMATION**



**IDENTIFICATION NUMBERS** ..... 1-1  
    PRIMARY I.D. NUMBER ..... 1-1  
    ENGINE SERIAL NUMBER ..... 1-1  
    PUMP SERIAL NUMBER..... 1-1  
    HULL IDENTIFICATION NUMBER  
    (H.I.N.) ..... 1-1

**SAFETY WHILE WORKING** ..... 1-2  
    FIRE PREVENTION ..... 1-2  
    VENTILATION ..... 1-2  
    SELF-PROTECTION ..... 1-2  
    OILS, GREASES AND SEALING FLUIDS ..... 1-2  
    GOOD WORKING PRACTICES ..... 1-3  
    DISASSEMBLY AND ASSEMBLY ..... 1-4

**SPECIAL TOOLS** ..... 1-5  
    MEASURING ..... 1-5  
    REMOVAL AND INSTALLATION..... 1-6



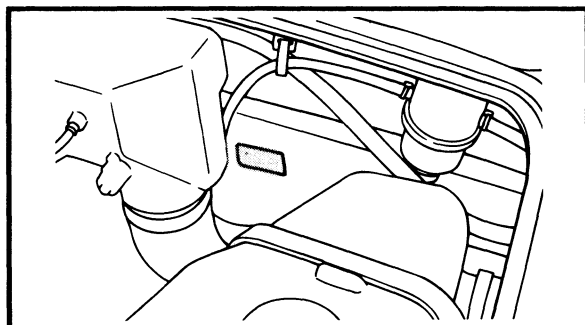

A60700-0\*

**IDENTIFICATION NUMBERS  
PRIMARY I.D. NUMBER**

The primary I.D. number is stamped on a label attached to the inside of the engine compartment.

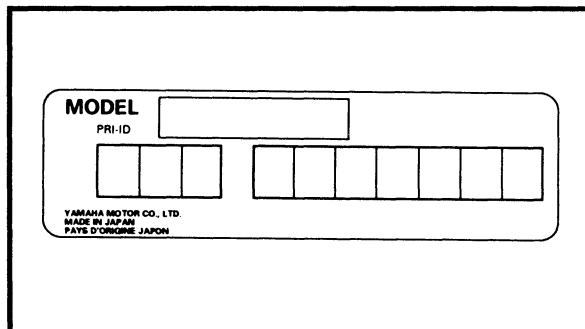

**Starting primary I.D. number:**

**GM6: 900101 ~,  
910101 ~ (FRA),  
930101 ~ (GUM, AUS)**

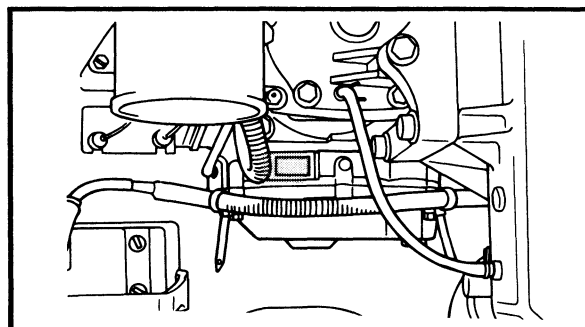

**ENGINE SERIAL NUMBER**

The engine serial number is stamped on a label attached to the crankcase.

**Starting serial number:**

**64V: 000101 ~**

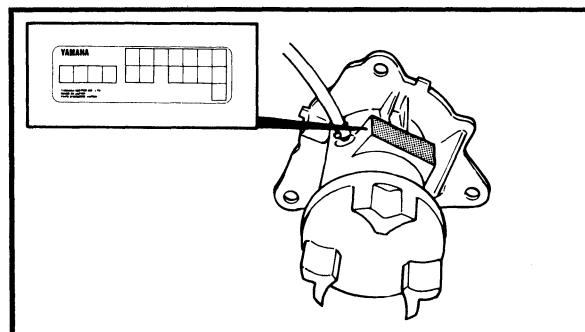

**PUMP SERIAL NUMBER**

The jet pump unit serial number is stamped on a label attached on the intermediate housing.

**Starting serial number:**

**64V: 500101 ~**

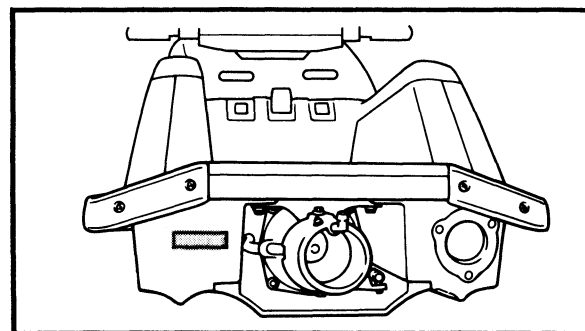

**HULL IDENTIFICATION NUMBER  
(H.I.N.)**

The H.I.N. is stamped on a plate attached to the hull beside the jet nozzle.



## SAFETY WHILE WORKING

The procedures given in this manual are those recommended by Yamaha to be followed by Yamaha dealers and their mechanics.

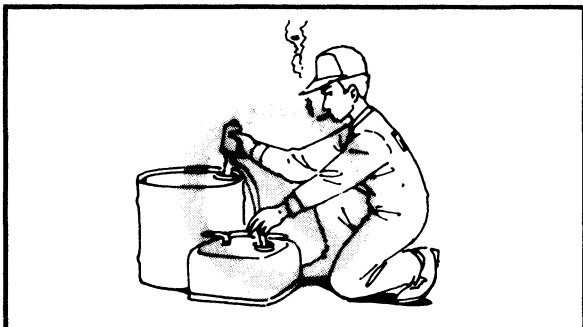

### FIRE PREVENTION

Gasoline (petrol) is highly flammable. Petroleum vapor is explosive if ignited. Do not smoke while handling gasoline (petrol), and keep it away from heat, sparks, and open flames.

### VENTILATION

Petroleum vapor is heavier than air and if inhaled in large quantities will not support life. Engine exhaust gases are harmful to breathe. When test-running an engine indoors, maintain good ventilation.

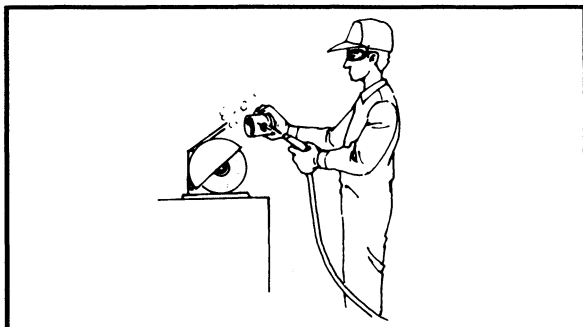

### SELF-PROTECTION

Protect your eyes with suitable safety spectacles or safety goggles when using compressed air, when grinding or when doing any operation which may cause particles to fly off.

Protect hands and feet by wearing safety gloves or protective shoes if appropriate to the work you are doing.

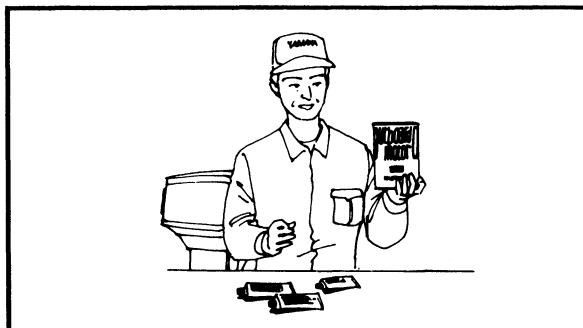

### OILS, GREASES AND SEALING FLUIDS

Use only genuine Yamaha oils, greases and sealing fluids or those recommended by Yamaha.