

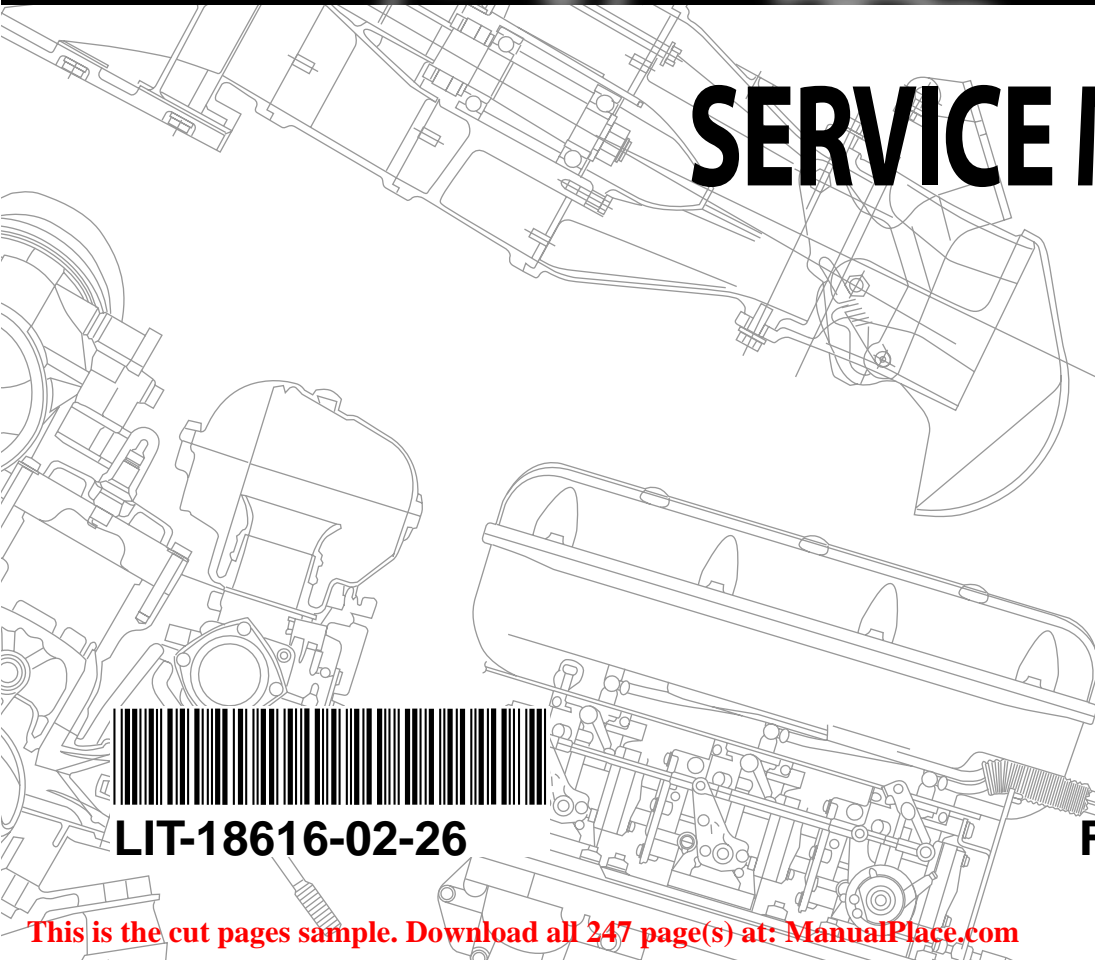

WaveRunner GP800R



SERVICE MANUAL



LIT-18616-02-26

F0W-28197-1A-11

NOTICE

This manual has been prepared by Yamaha primarily for use by Yamaha dealers and their trained mechanics when performing maintenance procedures and repairs to Yamaha equipment. It has been written to suit the needs of persons who have a basic understanding of the mechanical and electrical concepts and procedures inherent in the work, for without such knowledge attempted repairs or service to the equipment could render it unsafe or unfit for use.

Because Yamaha has a policy of continuously improving its products, models may differ in detail from the descriptions and illustrations given in this publication. Use only the latest edition of this manual. Authorized Yamaha dealers are notified periodically of modifications and significant changes in specifications and procedures, and these are incorporated in successive editions of this manual.

A10001-0*

**WaveRunner GP800R
SERVICE MANUAL
©2000 by Yamaha Motor Corporation, USA
1st Edition, November 2000
All rights reserved.
Any reprinting or unauthorized use
without the written permission of
Yamaha Motor Corporation, USA
is expressly prohibited.
Printed in USA
LIT-18616-02-26**

HOW TO USE THIS MANUAL

MANUAL FORMAT

All of the procedures in this manual are organized in a sequential, step-by-step format. The information has been compiled to provide the mechanic with an easy to read, handy reference that contains comprehensive explanations of all disassembly, repair, assembly, and inspection operations.

In this revised format, the condition of a faulty component will precede an arrow symbol and the course of action required will follow the symbol, e.g.,

- Bearings
Pitting/scratches → Replace.

To assist you in finding your way through this manual, the section title and major heading is given at the top of every page.

ILLUSTRATIONS

The illustrations within this service manual represent all of the designated models.

CROSS REFERENCES

The cross references have been kept to a minimum. Cross references will direct you to the appropriate section or chapter.

IMPORTANT INFORMATION

In this Service Manual particularly important information is distinguished in the following ways.

 The Safety Alert Symbol means ATTENTION! BECOME ALERT! YOUR SAFETY IS INVOLVED!

WARNING

Failure to follow WARNING instructions could result in severe injury or death to the machine operator, a bystander, or a person inspecting or repairing the watercraft.

CAUTION:

A CAUTION indicates special precautions that must be taken to avoid damage to the watercraft.

NOTE:

A NOTE provides key information to make procedures easier or clearer.

IMPORTANT:

This part has been subjected to change of specification during production.

HOW TO USE THIS MANUAL

- ① To help identify parts and clarify procedure steps, there are exploded diagrams at the start of each removal and disassembly section.
- ② Numbers are given in the order of the jobs in the exploded diagram.
- ③ Symbols indicate parts to be lubricated or replaced (see "SYMBOLS").
- ④ A job instruction chart accompanies the exploded diagram, providing the order of jobs, names of parts, notes in jobs, etc.
- ⑤ Dimension figures and the number of parts, are provided for fasteners that require a tightening torque.

Example:

Bolt or screw size 10 × 25 mm : M10 (D) × 25 mm (L)

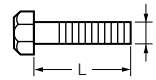

- ⑥ Jobs requiring more information (such as special tools and technical data) are described sequentially.

JET PUMP NOZZLE DEFLECTOR AND NOZZLE RING

NOZZLE DEFLECTOR AND NOZZLE RING
EXPLODED DIAGRAM

REMOVAL AND INSTALLATION CHART

Step	Procedure/Part name	Q'ty	Service points
NOZZLE DEFLECTOR AND NOZZLE RING REMOVAL			
	Jet pump unit		Follow the left "Step" for removal.
1	Bolt	2	Refer to "JET PUMP UNIT".
2	Collar	2	
3	Nozzle deflector	1	
4	Bolt	2	
5	Collar	2	
6	Nozzle ring	1	
Reverse the removal steps for installation.			

6-4

JET PUMP IMPELLER DUCT AND DRIVE SHAFT

SERVICE POINTS

Drive shaft removal

1. Remove:
 - Impeller

NOTE:
The impeller has left-hand threads. Turn the impeller clockwise to loosen it.

2. Remove:
 - Nut ①

NOTE:
Remove the drive shaft with a press.

3. Remove:
 - Drive shaft ①

NOTE:
Remove the drive shaft with a press.

4. Remove:
 - Rear bearing

Slide hammer set:
YB-06096
Stopper guide plate:
90890-06501
Bearing puller:
90890-06535
Bearing puller claw 1:
90890-06536
Stopper guide stand:
90890-06538

Ⓐ For USA and Canada
Ⓑ For worldwide

















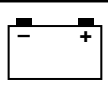





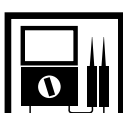

6-9

A50001-1-4

SYMBOLS

Symbols ① to ⑨ are designed as thumb-tabs to indicate the content of a chapter.

- ① General Information
- ② Specifications
- ③ Periodic Inspection and Adjustment
- ④ Fuel System
- ⑤ Power Unit
- ⑥ Jet Pump Unit
- ⑦ Electrical System
- ⑧ Hull and Hood
- ⑨ Trouble analysis

① GEN INFO 	② SPEC 
③ INSP ADJ 	④ FUEL 
⑤ POWR 	⑥ JET PUMP 
⑦ ELEC 	⑧ HULL HOOD 
⑨ TRBL ANLS 	⑩ 
⑪ 	⑫ 
⑬ 	⑭ 
⑮ 	⑯ 
⑰ 	⑱ 
⑲ 	⑳ 
㉑ 	㉒ 
㉓ 	㉔ 

Symbols ⑩ to ⑮ indicate specific data:

- ⑩ Special tool
- ⑪ Specified liquid
- ⑫ Specified engine speed
- ⑬ Specified torque
- ⑭ Specified measurement
- ⑮ Specified electrical value
[Resistance (Ω), Voltage (V), Electric current (A)]

Symbol ⑯ to ⑲ in an exploded diagram indicate the grade of lubricant and the location of lubrication point:









- ⑯ Apply YAMALUBE 2-W oil or TC-W3 certified outboard oil
- ⑰ Apply water resistant grease (Yamaha grease A, Yamaha marine grease)
- ⑱ Apply molybdenum disulfide grease

Symbols ⑲ to ㉔ in an exploded diagram indicate the grade of the sealing or locking agent, and the location of the application point:

- ⑲ Apply Gasket Maker®
- ⑳ Apply Yamabond #4 (Yamaha bond number 4)
- ㉑ Apply LOCTITE® No. 271 (Red LOCTITE)
- ㉒ Apply LOCTITE® No. 242 (Blue LOCTITE)
- ㉓ Apply LOCTITE® No. 572
- ㉔ Apply silicone sealant

NOTE: _____
In this manual, the above symbols may not be used in every case.

INDEX

GENERAL INFORMATION	 GEN INFO	1
SPECIFICATIONS	 SPEC	2
PERIODIC INSPECTION AND ADJUSTMENT	 INSP ADJ	3
FUEL SYSTEM	 FUEL	4
POWER UNIT	 POWR	5
JET PUMP UNIT	 JET PUMP	6
ELECTRICAL SYSTEM	 ELEC	7
HULL AND HOOD	 HULL HOOD	8
TROUBLE ANALYSIS	 TRBL ANLS	9

CHAPTER 1 GENERAL INFORMATION



IDENTIFICATION NUMBERS	1-1
PRIMARY I.D. NUMBER.....	1-1
ENGINE SERIAL NUMBER.....	1-1
JET PUMP UNIT SERIAL NUMBER.....	1-1
HULL IDENTIFICATION NUMBER (H.I.N.).....	1-1
⚠ SAFETY WHILE WORKING	1-2
FIRE PREVENTION.....	1-2
VENTILATION.....	1-2
SELF-PROTECTION.....	1-2
OILS, GREASES AND SEALING FLUIDS.....	1-2
GOOD WORKING PRACTICES.....	1-3
DISASSEMBLY AND ASSEMBLY.....	1-4
SPECIAL TOOLS	1-5
MEASURING.....	1-5
REMOVAL AND INSTALLATION.....	1-6

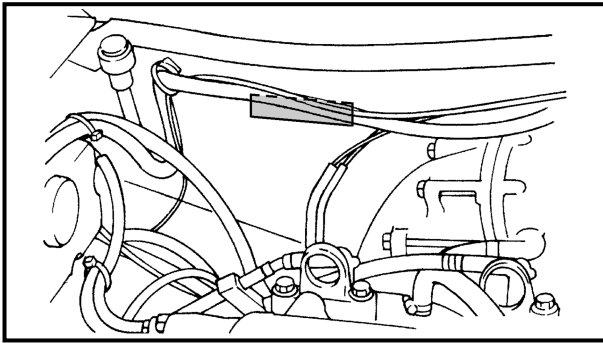

A60700-0*

**IDENTIFICATION NUMBERS
PRIMARY I.D. NUMBER**

The primary I.D. number is stamped on a label attached to the inside of the engine compartment.

**Starting primary I.D. number:
F0W: 800101-**

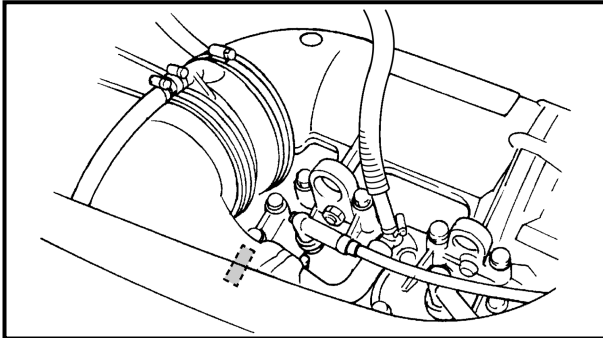

ENGINE SERIAL NUMBER

The engine serial number is stamped on a label attached to the cylinder head.

**Starting serial number:
68A: 000101-**

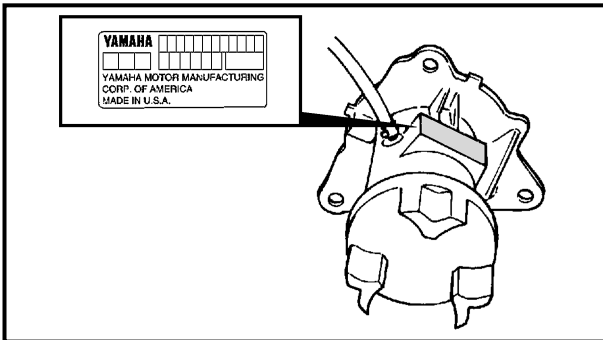

JET PUMP UNIT SERIAL NUMBER

The jet pump unit serial number is stamped on a label attached to the intermediate housing.

**Starting serial number:
68A: 800101-**

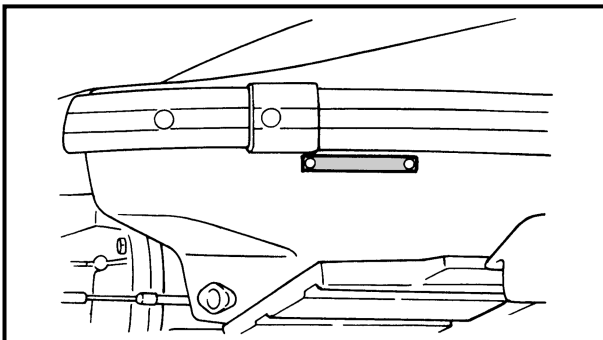

**HULL IDENTIFICATION NUMBER
(H.I.N.)**

The H.I.N. is stamped on a plate attached to the aft deck.

⚠ SAFETY WHILE WORKING

The procedures given in this manual are those recommended by Yamaha to be followed by Yamaha dealers and their mechanics.

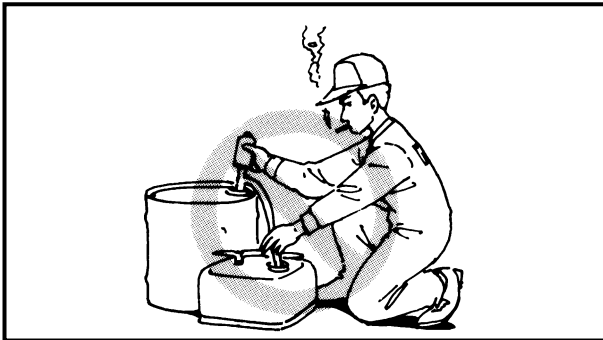
**FIRE PREVENTION**

Gasoline (petrol) is highly flammable. Gasoline vapor is explosive if ignited. Do not smoke while handling gasoline (petrol) and keep it away from heat, sparks, and open flames.

VENTILATION

Gasoline vapor is heavier than air and is deadly if inhaled in large quantities. Engine exhaust gases are harmful to breathe. When test-running an engine indoors, maintain good ventilation.

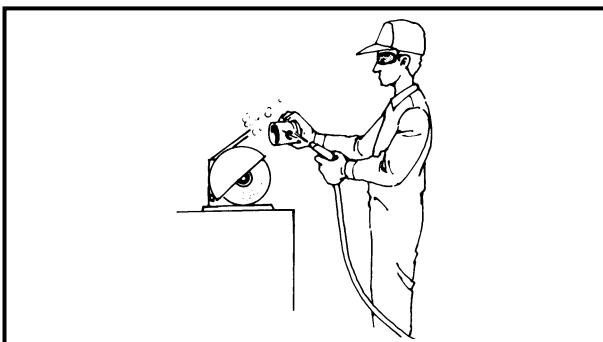
**SELF-PROTECTION**

Protect your eyes with suitable safety spectacles or safety goggles when grinding or doing any operation which may cause particles to fly off.

Protect hands and feet by wearing safety gloves or protective shoes if appropriate to the work you are doing.

**OILS, GREASES AND SEALING FLUIDS**

Use only genuine Yamaha oils, greases, and sealing fluids or those recommended by Yamaha.

Under normal conditions of use there should be no hazards from the use of the lubricants mentioned in this manual, but safety is all-important, and by adopting good safety practises any risk is minimized. A summary of the most important precautions is as follows:

1. While working, maintain good standards of personal and industrial hygiene.
2. Clothing which has become contaminated with lubricants should be changed as soon as practicable and laundered before further use.
3. Avoid skin contact with lubricants (e.g., do not place a soiled rag in your pocket).
4. Hands and any other part of the body which have been in contact with lubricants or lubricant-contaminated clothing should be thoroughly washed with hot water and soap as soon as practicable.
5. To protect the skin, the application of a suitable barrier cream to the hands before working is recommended.
6. A supply of clean lint-free cloths should be available for wiping purposes.



GOOD WORKING PRACTICES

1. The right tools

Use the recommended special tools to protect parts from damage. Use the right tool in the right manner – do not improvise.

2. Tightening torque

Follow the tightening torque instructions. When tightening bolts, nuts and screws, tighten the larger sizes first and tighten inner-positioned fixings before outer-positioned ones.

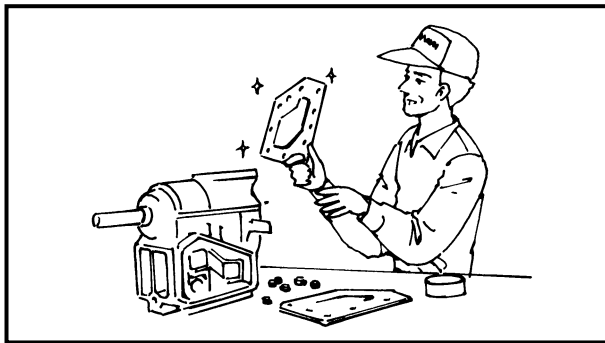

3. Non-reusable items

Always use new gaskets, packings, O-rings, oil seals, split-pins, circlips, etc., on reassembly.

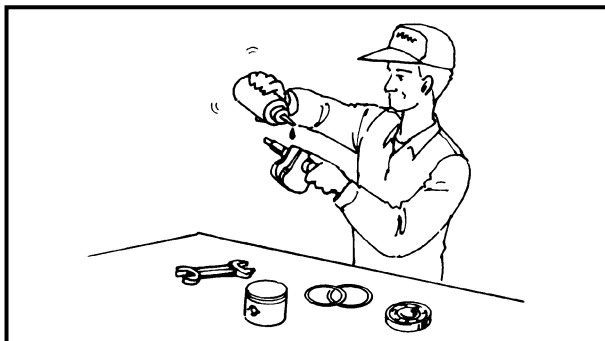

DISASSEMBLY AND ASSEMBLY

1. Clean parts with compressed air when disassembling.
2. Oil the contact surfaces of moving parts during assembly.

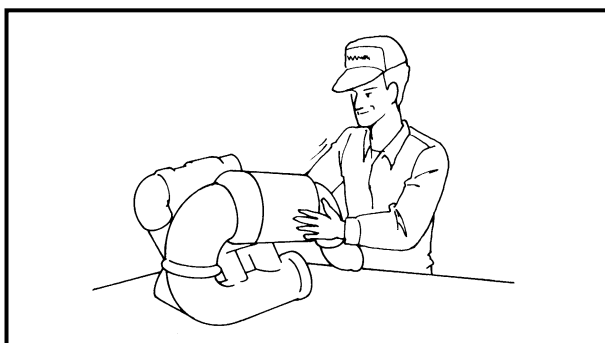

3. After assembly, check that moving parts operate normally.

4. Install bearings with the manufacturer's markings on the side exposed to view and liberally oil the bearings.

CAUTION: _____

Do not spin bearings with compressed air because this will damage their surfaces.

5. When installing oil seals, apply a light coat of water-resistant grease to the outside diameter.

SPECIAL TOOLS

Using the correct special tools recommended by Yamaha, will aid the work and enable accurate assembly and tune-up. Improvisations and using improper tools can damage the equipment.

NOTE:

- For U.S.A. and Canada, use part numbers starting with "J-", "YB-", "YM-", "YU-" or "YW-".
- For other countries, use part numbers starting with "90890-".

MEASURING

- ① Engine tachometer
P/N. YU-8036-A
90890-06760
- ② Dial gauge and stand
P/N. YU-03097, YU-01256
90890-01252
- ③ Pocket tester
P/N. YU-03112
90890-03112
- ④ Cylinder gauge set
P/N. YU-03017
90890-06759
- ⑤ Compression gauge
P/N. YU-33223
90890-03160
- ⑥ Digital tester
P/N. J-39299
90890-06752
- ⑦ Peak voltage adapter
P/N. YU-39991
90890-03169
- ⑧ Peak voltage test harness
P/N. YW-06779
90890-06779
- ⑨ Spark gap tester
P/N. YM-34487
90890-06754

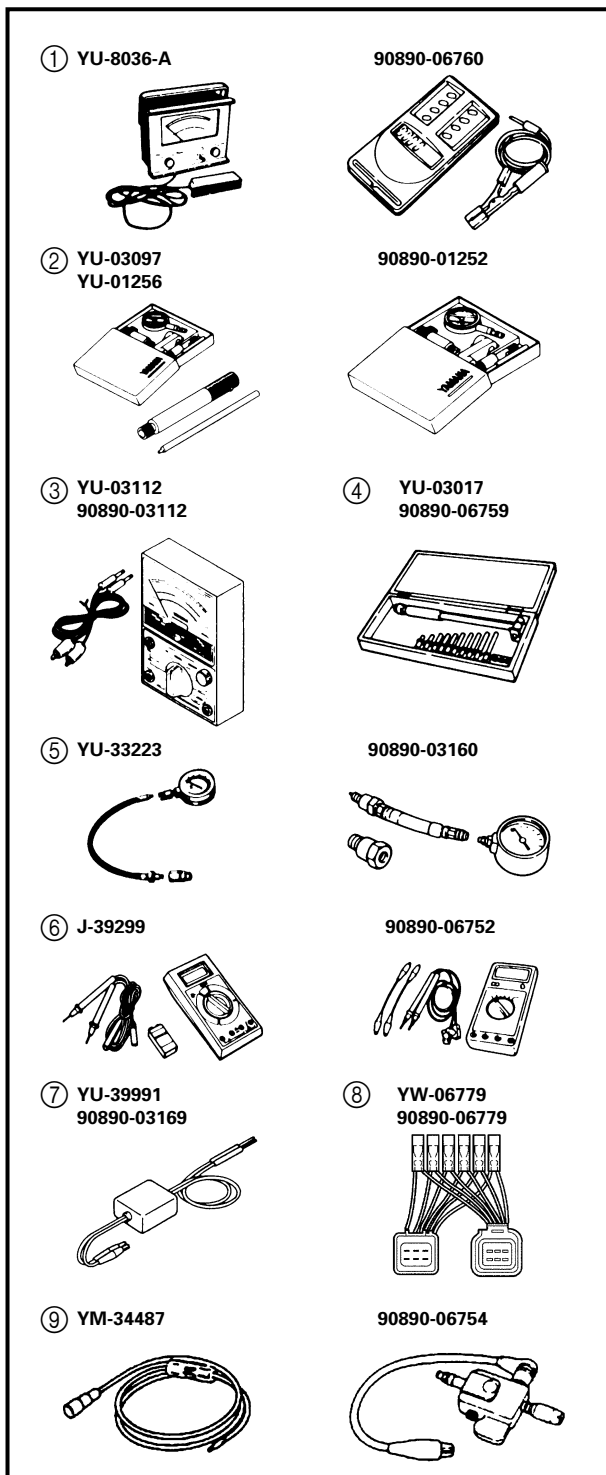

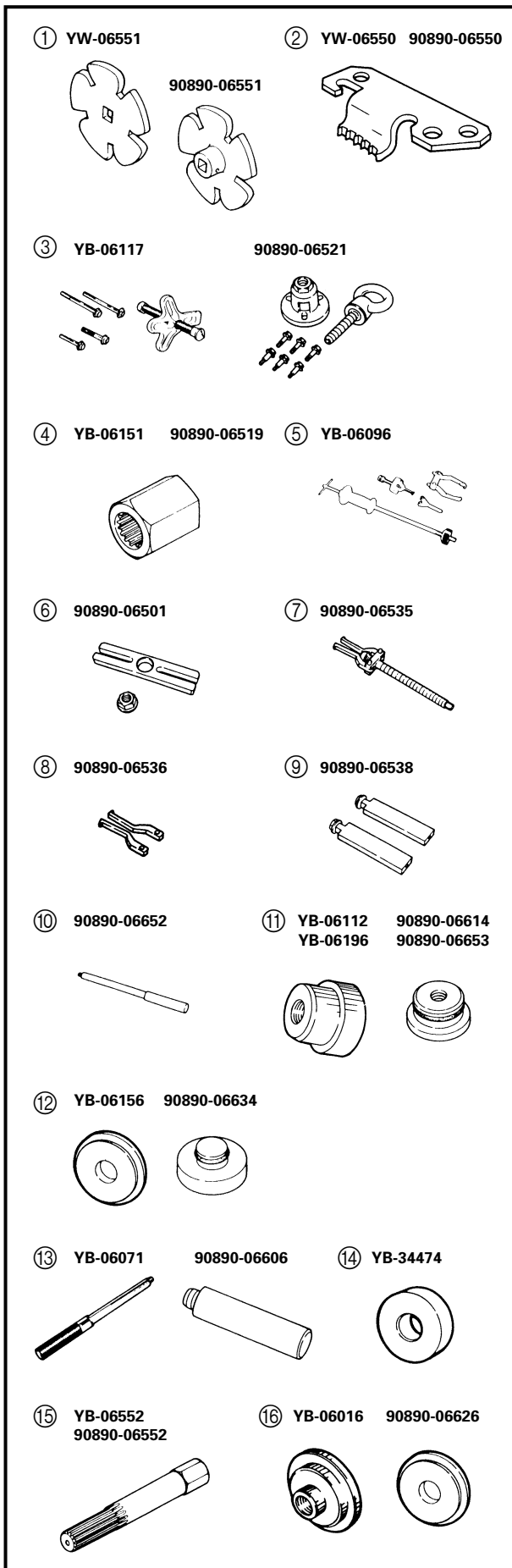

REMOVAL AND INSTALLATION

- ① Coupler wrench
P/N. YW-06551
90890-06551
- ② Flywheel holder
P/N. YW-06550
90890-06550
- ③ Flywheel puller
P/N. YB-06117
90890-06521
- ④ Drive shaft holder (impeller)
P/N. YB-06151
90890-06519
- ⑤ Slide hammer set (jet pump bearing)
P/N. YB-06096
- ⑥ Stopper guide plate (jet pump bearing)
P/N. 90890-06501
- ⑦ Bearing puller (jet pump bearing)
P/N. 90890-06535
- ⑧ Bearing puller claw 1 (jet pump bearing)
P/N. 90890-06536
- ⑨ Stopper guide stand (jet pump bearing)
P/N. 90890-06538
- ⑩ Drive rod L3 (jet pump bearing)
P/N. 90890-06652
- ⑪ Needle bearing attachment
(jet pump bearing and oil seal)
P/N. YB-06112, YB-06196
90890-06614, 90890-06653
- ⑫ Ball bearing attachment
(jet pump oil seal)
P/N. YB-06156
90890-06634
- ⑬ Driver rod
(intermediate shaft and jet pump)
P/N. YB-06071
90890-06606
- ⑭ Bearing inner/outer race attachment
(jet pump bearing)
P/N. YB-34474
- ⑮ Shaft holder (intermediate shaft)
P/N. YB-06552
90890-06552
- ⑯ Bearing outer race attachment
(intermediate shaft)
P/N. YB-06016
90890-06626

CHAPTER 2 SPECIFICATIONS

GENERAL SPECIFICATIONS..... 2-1

MAINTENANCE SPECIFICATIONS..... 2-3

ENGINE..... 2-3

JET PUMP UNIT..... 2-4

HULL AND HOOD..... 2-4

ELECTRICAL..... 2-5

TIGHTENING TORQUES..... 2-7

SPECIFIED TORQUES..... 2-7

GENERAL TORQUE..... 2-10

CABLE AND HOSE ROUTING..... 2-11

GENERAL SPECIFICATIONS

Item	Unit	Model
		GP800R
MODEL CODE		
Hull		F0W
Engine		68A
DIMENSIONS		
Length	mm (in)	2,930 (115.4)
Width	mm (in)	1,150 (45.3)
Height	mm (in)	1,020 (40.2)
Dry weight	kg (lb)	268 (591)
Watercraft capacity		2
PERFORMANCE		
Maximum output	kW (PS) @ r/min	88.2 (120) @ 7,000
Maximum fuel consumption	ℓ /h (US gal/h, Imp gal/h)	49 (12.9, 10.8)
Cruising range	h	1.2
ENGINE		
Engine type		2-stroke
Number of cylinders		2
Displacement	cm ³ (cu. in)	784 (47.8)
Bore × stroke	mm (in)	80.0 × 78.0 (3.15 × 3.07)
Compression ratio		6.6:1
Intake system		Reed valve
Carburetor model (manufacturer) × quantity		BN44 (Mikuni) × 2
Enrichment control		Choke valve
Scavenging system		Loop charge
Lubrication system		Oil injection
Cooling system		Water
Starting system		Electric
Ignition system		Digital CDI
Ignition timing	Degree	15 BTDC–20 BTDC
Spark plug model (manufacturer)		BR8ES (NGK)
Battery capacity	V/Ah (kC)	12/19 (68.4)
Lighting coil	max. A @ r/min	8 @ 6,000
Propulsion system		Jet pump
DRIVE UNIT		
Jet pump type		Axial flow, single stage
Impeller rotation (from rear)		Counterclockwise
Transmission		Direct drive from engine
Nozzle angle (horizontal)	Degree	23 + 23
Nozzle angle (vertical)	Degree	-5, 0, 5, 10, 15
Trim system		Manual 5 positions

Item	Unit	Model
		GP800R
FUEL AND OIL		
Fuel		Regular unleaded gasoline
Fuel rating	PON*	86
	RON*	90
Oil		YAMALUBE 2-W or an equivalent TC-W3 certified outboard oil
Fuel/oil mixing ratio (wide open throttle)		30:1
Fuel tank capacity	ℓ (US gal, Imp gal)	60 (15.9, 13.2)
Fuel tank reserve capacity	ℓ (US gal, Imp gal)	10 (2.6, 2.2)
Oil tank capacity	ℓ (US gal, Imp gal)	5.5 (1.45, 1.21)

PON*: Pump Octane Number = (Motor Octane Number + Research Octane Number)/2

RON*: Research Octane Number



MAINTENANCE SPECIFICATIONS

E

MAINTENANCE SPECIFICATIONS ENGINE

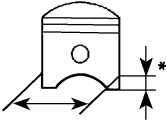
Item	Unit	Model
		GP800R
CYLINDER HEAD		
Warpage limit	mm (in)	0.1 (0.004)
Compression pressure* ¹	kPa (kg/cm ²)	560 (5.6)
CYLINDERS		
Bore size	mm (in)	80.000–80.018 (3.1496–3.1503)
Taper limit	mm (in)	0.08 (0.003)
Out-of-round limit	mm (in)	0.05 (0.002)
Wear limit	mm (in)	Original cylinder bore + 0.04 (0.0016)
PISTONS		
Diameter	mm (in)	Red: 79.899–79.902 (3.1456–3.1457) Orange: 79.903–79.906 (3.1458–3.1459) Green: 79.907–79.910 (3.1459–3.1461) Purple: 79.911–79.914 (3.1461–3.1462)
 Measuring point*	mm (in)	22 (0.87)
Piston-to-cylinder clearance	mm (in)	0.100–0.105 (0.0039–0.0041)
Wear limit	mm (in)	Cylinder bore – 0.105 (0.0041)
Piston pin bore inside diameter	mm (in)	22.004–22.025 (0.8663–0.8671)
PISTON RINGS		
Top		
Type		Keystone
Dimensions (B)	mm (in)	1.2 (0.05)
Dimensions (T)	mm (in)	2.85 (0.112)
End gap	mm (in)	0.30–0.45 (0.012–0.018)
Ring groove clearance	mm (in)	0.03–0.05 (0.001–0.002)
2nd* ²		
Type		Keystone
Dimensions (B)	mm (in)	1.2 (0.05)
Dimensions (T)	mm (in)	2.85 (0.112)
End gap	mm (in)	0.30–0.45 (0.012–0.018)
Ring groove clearance	mm (in)	0.03–0.05 (0.001–0.002)
PISTON PINS		
Diameter	mm (in)	21.995–22.000 (0.8659–0.8661)
Wear limit	mm (in)	21.990 (0.8657)

*1: At 760 mmHg and 20 °C (68 °F)

*2: The top ring and 2nd ring are of the same type.