

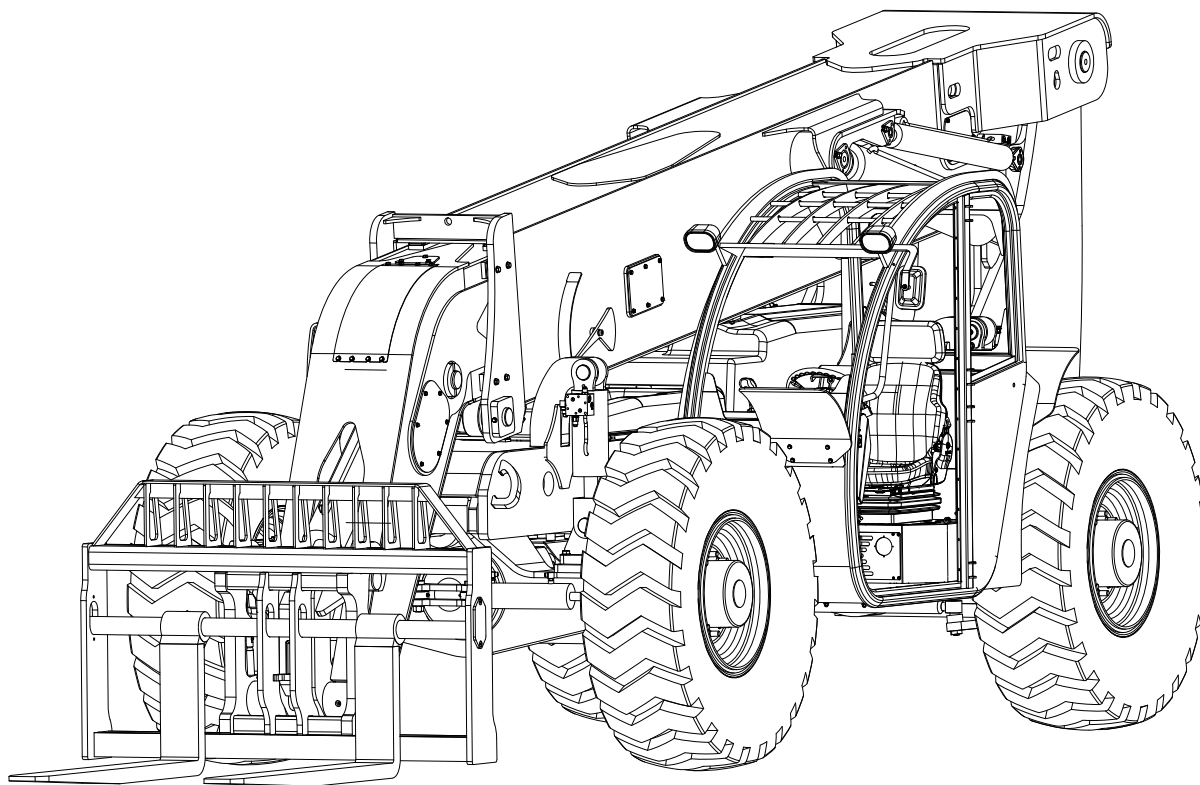

Illustrated Parts Breakdown Manual

Forward Reach Forklift

Model XR3034



**Xtreme Manufacturing
1415 West Bonanza Road
Las Vegas, NV 89106
(702) 636-2969**

**www.xtrememanufacturing.com
Copyright © 2010 By Xtreme Manufacturing**

List of Effective Pages

This manual consists of 314 pages as listed below:

- Outside title page
- Inside title page
- Pages A through D
- Pages i through x
- Pages 1-1 through 1-2
- Pages 2-1 through 2-14
- Pages 3-1 through 3-18
- Pages 4-1 through 4-14
- Pages 5-1 through 5-12
- Pages 6-1 through 6-18
- Pages 7-1 through 7-50
- Pages 8-1 through 8-24
- Pages 9-1 through 9-22
- Pages 10-1 through 10-34
- Pages 11-1 through 11-12
- Index 1 through Index 78
- Warranty 1 through Warranty 2
- Inside back cover
- Outside back cover

THIS PAGE INTENTIONALLY LEFT BLANK

Table of Contents

<u>Chap./Par.</u>	<u>Title</u>	<u>Page</u>
	List of Effective Pages	A
	Service Bulletins	B
	Design Change Notices	C
	Alphabetical List of Parts Breakdowns	ii
	Numerical List of Parts Breakdowns	v
	Section 1 – General Information	1-1
	Section 2 – Chassis	2-1
	Section 3 – Decals and Load Charts	3-1
	Section 4 – Engine	4-1
	Section 5 – Transmission, Axles, and Driveshafts	5-1
	Section 6 – Steering, Brakes, Wheels, and Tires	6-1
	Section 7 – Hydraulic System	7-1
	Section 8 – Electrical System	8-1
	Section 9 – Boom	9-1
	Section 10 – Cab and Consoles	10-1
	Section 11 – Boom Attachments	11-1
	Numerical and Alphabetical Indexes	Index 1

Alphabetical List of Parts Breakdowns

<u>Title</u>	<u>Figure No.</u>	<u>Page No.</u>
Accelerator Pedal Assembly	10-7.....	10-17
Accumulator Assembly.....	6-7.....	6-14
Air Cleaner Assembly.....	4-4.....	4-11
Angle Indicator Assembly.....	9-4.....	9-13
Auxiliary Manifold Assembly	7-8.....	7-17
Battery Cover Assembly.....	10-11.....	10-27
Battery Disconnect Switch Assembly.....	8-8.....	8-19
Boom Assembly	9-1.....	9-2
Boom Manifold Assembly.....	7-6.....	7-13
Brake Charge Valve Assembly	6-6.....	6-12
Brake Return Filter Assembly	6-5.....	6-10
Brake Return Manifold Assembly.....	6-4.....	6-8
Cab Assembly	10-1.....	10-2
Carriage Tilt Cylinder Assembly.....	7-18.....	7-38
Chassis Assembly – Axles	2-4.....	2-9
Chassis Assembly – Cab	2-2.....	2-4
Chassis Assembly – Covers & Console.....	2-5.....	2-13
Chassis Assembly – Engine.....	2-3.....	2-6
Control Valve Cover Assembly	10-5.....	10-12
Control Valve Cover Subassembly	10-6.....	10-15
Control Enclosure Subassembly.....	10-4.....	10-10
Distribution Manifold Assembly.....	7-4.....	7-8
Electrical Assembly	8-1.....	8-2
Electrical Center Assembly	8-2.....	8-7
Engine Cover Assembly.....	10-9.....	10-22
Engine Relay Assembly	8-7.....	8-17
Engine Transmission Assembly.....	4-1.....	4-2
Extend Cylinder Assembly	7-16.....	7-34
Extend Cylinder Housing Assembly.....	7-17.....	7-36
Final Assembly.....	2-1.....	2-2
Fork Mounting Pin Assembly	11-5.....	11-11
Fork Positioning Carriage Assembly.....	11-2.....	11-4
Fork Positioning Manifold Assembly	7-9.....	7-20

Alphabetical List of Parts Breakdowns – Cont.

<u>Title</u>	<u>Figure No.</u>	<u>Page No.</u>
Front Axle Assembly	5-2.....	5-4
Front Axle Cylinder Assembly (LH).....	7-20.....	7-42
Front Axle Cylinder Assembly (RH)	7-19.....	7-40
Front Control Console Assembly	10-2.....	10-5
Front Control Panel Assembly	10-3.....	10-8
Front Cover Assembly.....	10-8.....	10-19
Front Driveshaft Assembly.....	5-4.....	5-8
Front Handle Assembly.....	7-11.....	7-24
Fuel Tank Assembly.....	4-5.....	4-13
Fuse Block Assembly.....	8-9.....	8-21
High-Pressure Filter/Steering Valve Assembly.....	7-3.....	7-6
Hydraulic Tank Assembly.....	7-1.....	7-2
Hydraulic Tank Lid Assembly.....	7-2.....	7-4
Inner Boom Assembly	9-2.....	9-6
Isolation Manifold Assembly.....	7-5.....	7-10
Knuckle Assembly.....	11-3.....	11-7
Labels and Load Charts	3-1.....	3-2
Latch Pin Assembly.....	11-4.....	11-9
Lift Cylinder Assembly.....	7-15.....	7-32
Lift Manifold Assembly	7-7.....	7-15
Master Cylinder Assembly	7-14.....	7-30
Operator Control Valve Assembly.....	7-10.....	7-22
Outer Boom Assembly	9-3.....	9-10
Outer Boom Roller Assembly.....	9-6.....	9-17
Overflow Tank Assembly	4-3.....	4-9
Radiator Assembly	4-2.....	4-6
Radiator Cover Assembly	10-10.....	10-25
Radiator Shroud Assembly	10-13.....	10-32
Rear Axle Assembly.....	5-3.....	5-6
Rear Axle Cylinder Assembly (LH)	7-22.....	7-46
Rear Axle Cylinder Assembly (RH).....	7-21.....	7-44
Rear Axle Lock Manifold Assembly	7-23.....	7-48
Rear Driveshaft Assembly.....	5-5.....	5-10
Rear Handle Assembly	7-13.....	7-28

Alphabetical List of Parts Breakdowns – Cont.

<u>Title</u>	<u>Figure No.</u>	<u>Page No.</u>
Rear Light Assembly	10-12.....	10-30
Relay Panel Assembly	8-3.....	8-9
Retract Spring Stack	9-8.....	9-21
Roller Assembly	9-7.....	9-19
Slide Block Assembly.....	9-5.....	9-15
Solenoid Assembly.....	8-10.....	8-23
Standard Carriage Assembly	11-1.....	11-2
Steer Cylinder Assembly.....	6-2.....	6-4
Steering Column Assembly.....	6-1.....	6-2
Steering Sensor Assembly.....	6-3.....	6-6
Sway Handle Assembly	7-12.....	7-26
Terminal Strip Assembly	8-4.....	8-11
Terminal Strip Assembly	8-5.....	8-13
Terminal Strip Assembly	8-6.....	8-15
Transmission and Pump Assembly.....	5-1.....	5-2
Wheel Tire Assembly	6-8.....	6-16

Numerical List of Parts Breakdowns

<u>Figure No.</u>	<u>Title</u>	<u>Page No.</u>
2-1	Final Assembly	2-2
2-2	Chassis Assembly – Cab	2-4
2-3	Chassis Assembly – Engine	2-6
2-4	Chassis Assembly – Axles	2-9
2-5	Chassis Assembly – Covers & Console	2-13
3-1	Labels and Load Charts	3-2
4-1	Engine Transmission Assembly	4-2
4-2	Radiator Assembly	4-6
4-3	Overflow Tank Assembly	4-9
4-4	Air Cleaner Assembly	4-11
4-5	Fuel Tank Assembly	4-13
5-1	Transmission and Pump Assembly	5-2
5-2	Front Axle Assembly	5-4
5-3	Rear Axle Assembly	5-6
5-4	Front Driveshaft Assembly	5-8
5-5	Rear Driveshaft Assembly	5-10
6-1	Steering Column Assembly	6-2
6-2	Steer Cylinder Assembly	6-4
6-3	Steering Sensor Assembly	6-6
6-4	Brake Return Manifold Assembly	6-8
6-5	Brake Return Filter Assembly	6-10
6-6	Brake Charge Valve Assembly	6-12
6-7	Accumulator Assembly	6-14
6-8	Wheel Tire Assembly	6-16
7-1	Hydraulic Tank Assembly	7-2
7-2	Hydraulic Tank Lid Assembly	7-4
7-3	High-Pressure Filter/Steering Valve Assembly	7-6
7-4	Distribution Manifold Assembly	7-8
7-5	Isolation Manifold Assembly	7-10
7-6	Boom Manifold Assembly	7-13
7-7	Lift Manifold Assembly	7-15
7-8	Auxiliary Manifold Assembly	7-17
7-9	Fork Positioning Manifold Assembly	7-20

Numerical List of Parts Breakdowns – Cont.

<u>Figure No.</u>	<u>Title</u>	<u>Page No.</u>
7-10	Operator Control Valve Assembly	7-22
7-11	Front Handle Assembly	7-24
7-12	Sway Handle Assembly	7-26
7-13	Rear Handle Assembly	7-28
7-14	Master Cylinder Assembly	7-30
7-15	Lift Cylinder Assembly	7-32
7-16	Extend Cylinder Assembly	7-34
7-17	Extend Cylinder Housing Assembly	7-36
7-18	Carriage Tilt Cylinder Assembly	7-38
7-19	Front Axle Cylinder Assembly (RH)	7-40
7-20	Front Axle Cylinder Assembly (LH)	7-42
7-21	Rear Axle Cylinder Assembly (RH)	7-44
7-22	Rear Axle Cylinder Assembly (LH)	7-46
7-23	Rear Axle Lock Manifold Assembly	7-48
8-1	Electrical Assembly	8-2
8-2	Electrical Center Assembly	8-7
8-3	Relay Panel Assembly	8-9
8-4	Terminal Strip Assembly	8-11
8-5	Terminal Strip Assembly	8-13
8-6	Terminal Strip Assembly	8-15
8-7	Engine Relay Assembly	8-17
8-8	Battery Disconnect Switch Assembly	8-19
8-9	Fuse Block Assembly	8-21
8-10	Solenoid Assembly	8-23
9-1	Boom Assembly	9-2
9-2	Inner Boom Assembly	9-6
9-3	Outer Boom Assembly	9-10
9-4	Angle Indicator Assembly	9-13
9-5	Slide Block Assembly	9-15
9-6	Outer Boom Roller Assembly	9-17
9-7	Roller Assembly	9-19
9-8	Retract Spring Stack	9-21
10-1	Cab Assembly	10-2
10-2	Front Control Console Assembly	10-5
10-3	Front Control Panel Assembly	10-8

Numerical List of Parts Breakdowns – Cont.

<u>Figure No.</u>	<u>Title</u>	<u>Page No.</u>
10-4	Control Enclosure Subassembly	10-10
10-5	Control Valve Cover Assembly	10-12
10-6	Control Valve Cover Subassembly	10-15
10-7	Accelerator Pedal Assembly	10-17
10-8	Front Cover Assembly	10-19
10-9	Engine Cover Assembly	10-22
10-10	Radiator Cover Assembly	10-25
10-11	Battery Cover Assembly	10-27
10-12	Rear Light Assembly	10-30
10-13	Radiator Shroud Assembly	10-32
11-1	Standard Carriage Assembly	11-2
11-2	Fork Positioning Carriage Assembly	11-4
11-3	Knuckle Assembly	11-7
11-4	Latch Pin Assembly	11-9
11-5	Fork Mounting Pin Assembly	11-11

Section 1

General Information

Table 1-1. Abbreviations & Acronyms

<u>Term</u>	<u>Meaning</u>
A	Amperes
ASTM	American Society for Testing and Materials
AWG	American Wire Gauge
BHC	Button head cap
BKDN	Breakdown
DIA	Diameter
DPDT	Double-pole, double-throw
FSHC	Flat socket head cap
FTG	Fittings
HHC	Hex head cap
ID	Inside diameter
LG	Long
MM	Millimeter
NHA	Next higher assembly
NPT	National pipe thread
OD	Outside diameter
OHM	Oval head machine
PHM	Pan head machine
PWH	Pan washer head
QD	Quick-Disconnect
REF	Reference
REG	Regular
SAE	Society of Automotive Engineers
SBHC	Socket button head cap
SHC	Socket head cap
SHS	Socket head shoulder

<u>Term</u>	<u>Meaning</u>
SPDT	Single-throw, double-pole
SPST	Single-pole, single-throw
STR	Straight
THD	Thread
UNC	Unified National Coarse
UNF	Unified National Fine
V	Volts

Section 2

Chassis

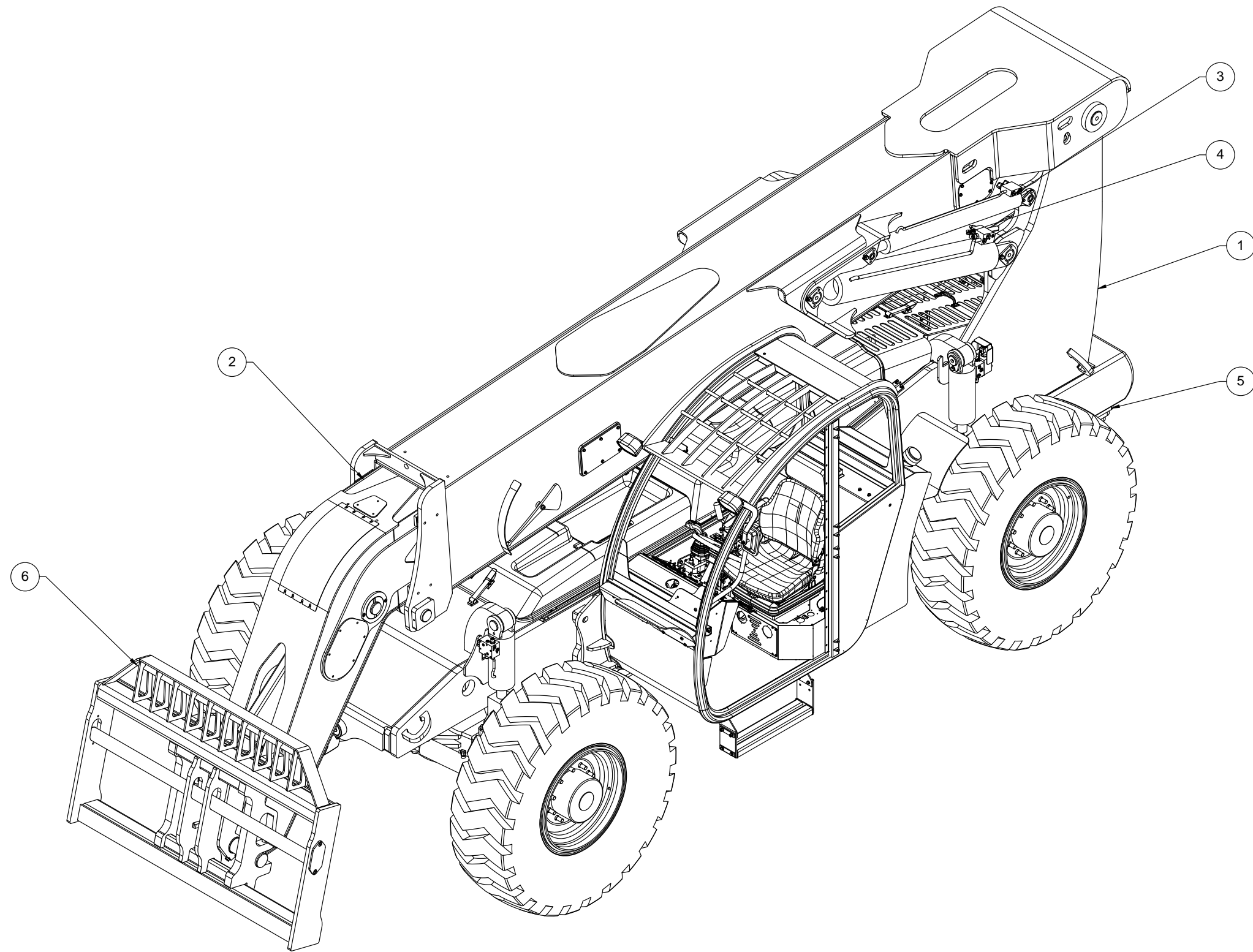

Figure 2-1. Final Assembly

Table 2-1. Final Assembly

Figure & Item No.	Part No.	Description	Quantity	Use On
–	27506-000	Final assembly	1	–
2-1-1	29018-000	Chassis assembly – cab	1	–
2-1-2	27509-000	Boom assembly	1	–
2-1-3	27515-000	Master cylinder assembly	2	–
2-1-4	27520-000	Lift cylinder assembly	2	–
2-1-5	27937-000	Counterweight	1	–
2-1-6	27511-000	Carriage assembly	1	–

Refer to Section 1 for the definition of acronyms and abbreviations used in the Description Column.

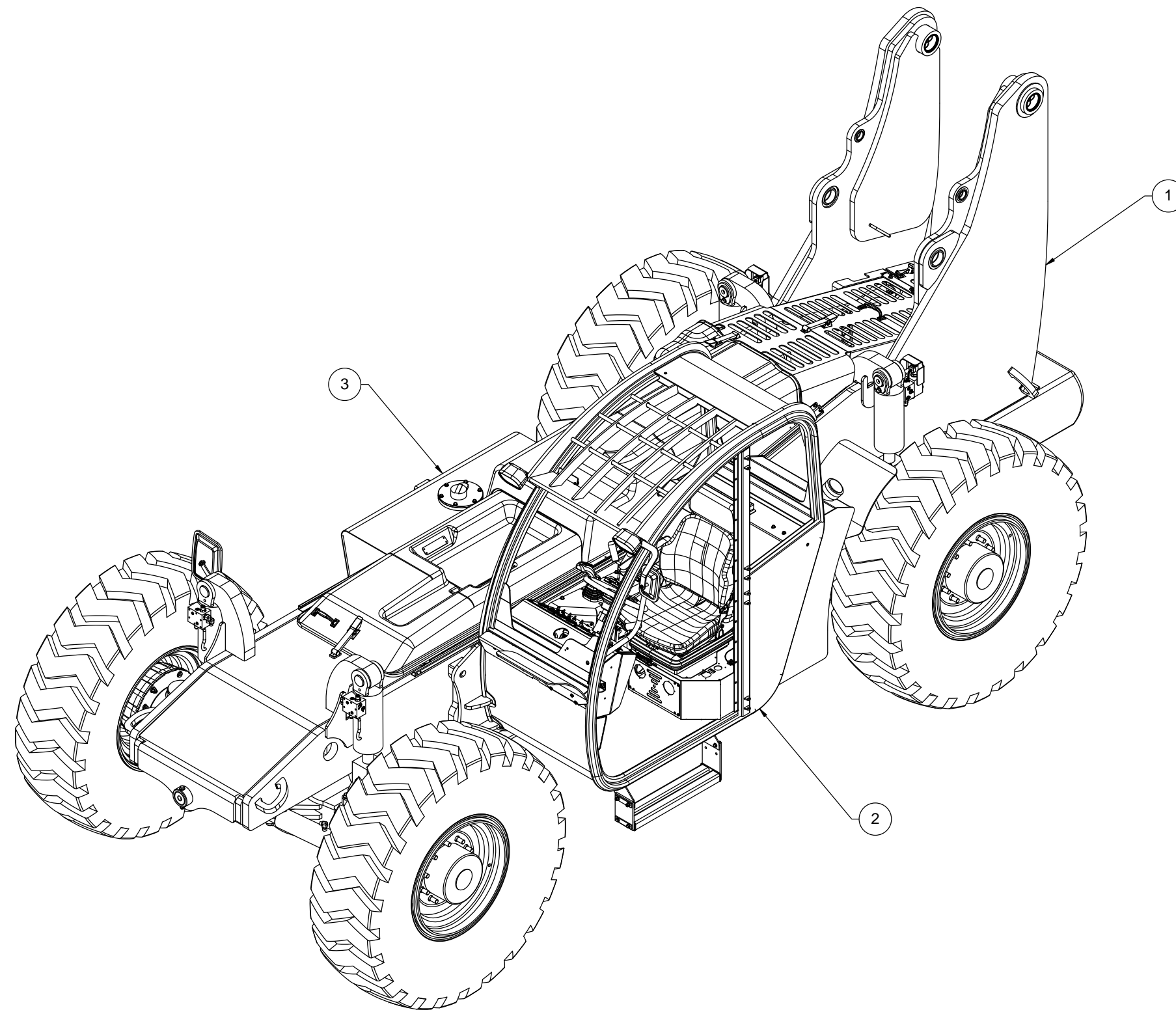

Figure 2-2. Chassis Assembly – Cab

Table 2-2. Chassis Assembly – Cab

Figure & Item No.	Part No.	Description	Quantity	Use On
–	29018-000	Chassis assembly – cab	–	–
2-2-1	29017-000	Chassis assembly – covers & console	1	–
2-2-2	27438-000	Cab assembly	1	–
2-2-3	29010-000	Hydraulic tank assembly	1	–

Refer to Section 1 for the definition of acronyms and abbreviations used in the Description Column.

ARTWORK TO BE SUPPLIED

Figure 2-3. Chassis Assembly – Engine