

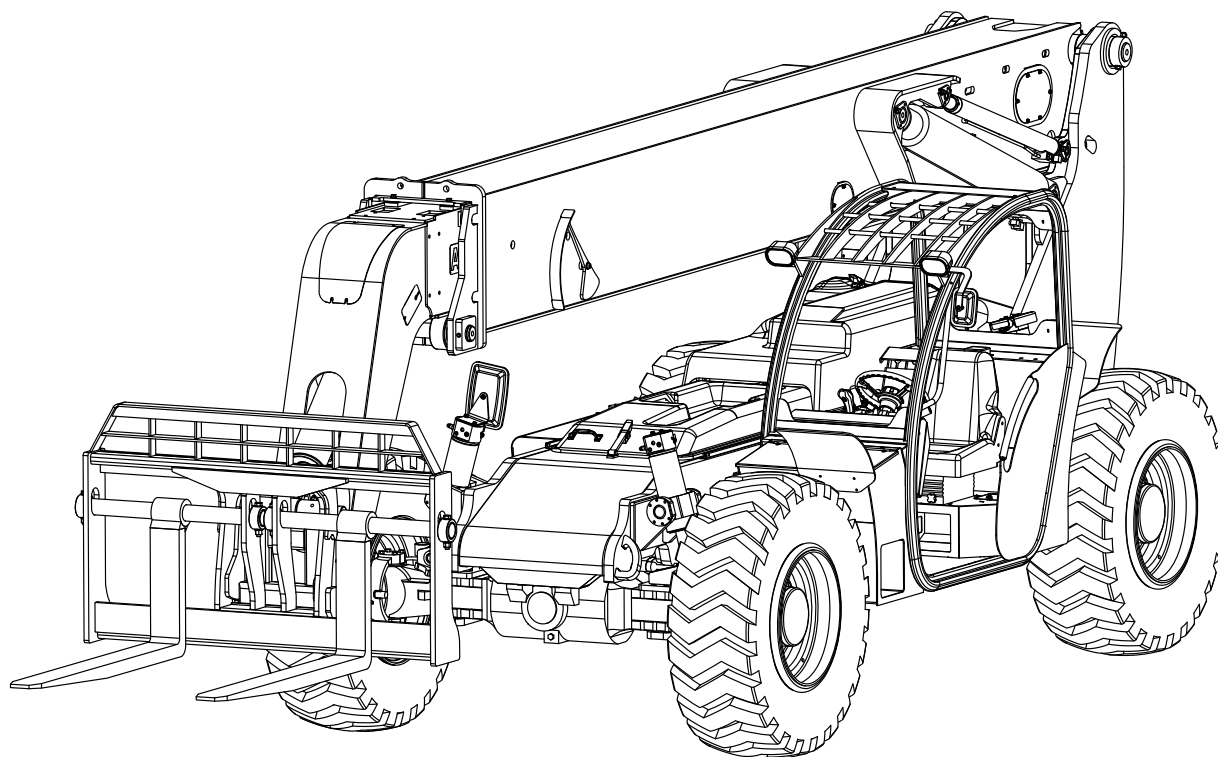

Illustrated Parts Breakdown Manual

Forward Reach Forklift

Model XR1642



**Xtreme Manufacturing
1415 West Bonanza Road
Las Vegas, NV 89106
(702) 636-2969
www.xtrememanufacturing.com**

Copyright © 2011 By Xtreme Manufacturing

List of Effective Pages

This manual consists of 320 pages as listed below:

- Outside title page
- Inside title page
- Pages A through D
- Pages i through x
- Pages 1-1 through 1-2
- Pages 2-1 through 2-18
- Pages 3-1 through 3-16
- Pages 4-1 through 4-14
- Pages 5-1 through 5-12
- Pages 6-1 through 6-14
- Pages 7-1 through 7-50
- Pages 8-1 through 8-22
- Pages 9-1 through 9-28
- Pages 10-1 through 10-40
- Pages 11-1 through 11-4
- Index 1 through Index 82
- Warranty 1 through Warranty 2
- Inside back cover
- Outside back cover

THIS PAGE INTENTIONALLY LEFT BLANK

Table of Contents

<u>Chap./Par.</u>	<u>Title</u>	<u>Page</u>
	List of Effective Pages	A
	Service Bulletins	B
	Design Change Notices	C
	Alphabetical List of Parts Breakdowns	ii
	Numerical List of Parts Breakdowns	v
	Section 1 – General Information	1-1
	Section 2 – Chassis	2-1
	Section 3 – Labels and Load Charts	3-1
	Section 4 – Engine	4-1
	Section 5 – Transmission, Axles, and Driveshafts	5-1
	Section 6 – Steering, Brakes, Wheels, and Tires	6-1
	Section 7 – Hydraulic System	7-1
	Section 8 – Electrical System	8-1
	Section 9 – Boom	9-1
	Section 10 – Cab and Consoles	10-1
	Section 11 – Boom Attachments	11-1
	Numerical and Alphabetical Indexes	Index 1

Alphabetical List of Parts Breakdowns

<u>Title</u>	<u>Figure No.</u>	<u>Page No.</u>
Accelerator Pedal Assembly	10-8.....	10-23
Accumulator Assembly.....	6-3.....	6-6
Adjustable Carriage Assembly	11-2.....	11-4
Air Cleaner Assembly.....	4-4.....	4-11
Angle Indicator Assembly.....	9-4.....	9-16
Basic Assembly	2-1.....	2-2
Battery Cover Assembly.....	10-12.....	10-33
Battery Disconnect Switch Assembly.....	8-7.....	8-17
Boom Assembly	9-1.....	9-2
Boom Hose Kit	7-21.....	7-45
Boom Manifold Assembly LH.....	7-8.....	7-19
Boom Manifold Assembly RH	7-9.....	7-21
Brake Charge Valve Assembly	6-4.....	6-8
Brake Pressure Switch Assembly	6-5.....	6-11
Brake Valve Assembly	6-2.....	6-4
Cab Assembly	10-1.....	10-2
Carriage Tilt Cylinder Assembly.....	7-17.....	7-37
Chassis Assembly – Axles.....	2-3.....	2-11
Chassis Assembly – Covers & Console.....	2-4.....	2-16
Chassis Assembly – Engine.....	2-2.....	2-4
Chassis Hose Kit.....	7-22.....	7-47
Control Enclosure Subassembly	10-5.....	10-15
Distribution Manifold Assembly.....	7-6.....	7-12
Electrical Assembly	8-1.....	8-2
Electrical Center Assembly	8-2.....	8-7
Enclosed Cab Assembly	10-2.....	10-8
Engine Cover Assembly.....	10-10.....	10-28
Engine Relay Assembly	8-6.....	8-15
Engine Transmission Assembly	4-1.....	4-2
Extend Cylinder Assembly	7-15.....	7-33
Extend Cylinder Housing Assembly.....	7-16.....	7-35
Filler Plate Assembly.....	10-15.....	10-39
Front Axle Assembly	5-2.....	5-4
Front Axle Cylinder Assembly.....	7-18.....	7-39

Alphabetical List of Parts Breakdowns – Cont.

<u>Title</u>	<u>Figure No.</u>	<u>Page No.</u>
Front Control Console Assembly	10-3.....	10-10
Front Control Panel Assembly	10-4.....	10-13
Front Cover Assembly.....	10-9.....	10-25
Front Driveshaft Assembly.....	5-4.....	5-8
Front Handle Assembly.....	7-11.....	7-25
Fuel Tank Assembly.....	4-5.....	4-13
Fuse Block Assembly.....	8-8.....	8-19
High-Pressure Filter/Steering Valve Assembly	7-5.....	7-10
Hose Clamp Assembly.....	9-9.....	9-26
Hydraulic Tank Assembly.....	7-1.....	7-2
Hydraulic Tank Lid Assembly.....	7-2.....	7-4
Inner Boom Assembly	9-2.....	9-5
Isolation Manifold Assembly.....	7-7.....	7-16
Labels and Load Charts	3-1.....	3-2
Lift Cylinder Assembly.....	7-14.....	7-31
Master Cylinder Assembly 2.75B.....	7-3.....	7-6
Master Cylinder Assembly 3.50B.....	7-4.....	7-8
Operator Control Valve Assembly.....	7-10.....	7-23
Outer Boom Assembly	9-3.....	9-11
Outer Boom Roller Assembly.....	9-6.....	9-20
Overflow Tank Assembly	4-3.....	4-9
Radiator Assembly	4-2.....	4-6
Radiator Cover Assembly	10-11.....	10-31
Radiator Shroud Assembly	10-14.....	10-37
Rear Axle Assembly.....	5-3.....	5-6
Rear Axle Cylinder Assembly.....	7-19.....	7-41
Rear Axle Lock Manifold Assembly	7-20.....	7-43
Rear Driveshaft Assembly.....	5-5.....	5-10
Rear Handle Assembly	7-13.....	7-29
Rear Light Assembly	10-13.....	10-35
Roller Assembly	9-7.....	9-22
Side Console Cover Assembly	10-7.....	10-21
Side Control Console Assembly	10-6.....	10-18
Slide Block Assembly.....	9-5.....	9-18

Alphabetical List of Parts Breakdowns – Cont.

<u>Title</u>	<u>Figure No.</u>	<u>Page No.</u>
Solenoid Assembly.....	8-9.....	8-21
Standard Carriage Assembly	11-1.....	11-2
Steering Column Assembly.....	6-1.....	6-2
Sway Handle Assembly	7-12.....	7-27
Terminal Strip Assembly	8-3.....	8-9
Terminal Strip Assembly	8-4.....	8-11
Terminal Strip Assembly	8-5.....	8-13
Transmission and Pump Assembly.....	5-1.....	5-2
Tube Clamp Assembly No. 2	9-8.....	9-24
Wheel Tire Assembly	6-6.....	6-13

Numerical List of Parts Breakdowns

<u>Figure No.</u>	<u>Title</u>	<u>Page No.</u>
2-1	Basic Assembly	2-2
2-2	Chassis Assembly – Engine	2-4
2-3	Chassis Assembly – Axles	2-11
2-4	Chassis Assembly – Covers & Console	2-16
3-1	Labels and Load Charts	3-2
4-1	Engine Transmission Assembly	4-2
4-2	Radiator Assembly	4-6
4-3	Overflow Tank Assembly	4-9
4-4	Air Cleaner Assembly	4-11
4-5	Fuel Tank Assembly	4-13
5-1	Transmission and Pump Assembly	5-2
5-2	Front Axle Assembly	5-4
5-3	Rear Axle Assembly	5-6
5-4	Front Driveshaft Assembly	5-8
5-5	Rear Driveshaft Assembly	5-10
6-1	Steering Column Assembly	6-2
6-2	Brake Valve Assembly	6-4
6-3	Accumulator Assembly	6-6
6-4	Brake Charge Valve Assembly	6-8
6-5	Brake Pressure Switch Assembly	6-11
6-6	Wheel Tire Assembly	6-13
7-1	Hydraulic Tank Assembly	7-2
7-2	Hydraulic Tank Lid Assembly	7-4
7-3	Master Cylinder Assembly 2.75B	7-6
7-4	Master Cylinder Assembly 3.50B	7-8
7-5	High-Pressure Filter/Steering Valve Assembly	7-10
7-6	Distribution Manifold Assembly	7-12
7-7	Isolation Manifold Assembly	7-16
7-8	Boom Manifold Assembly LH	7-19
7-9	Boom Manifold Assembly RH	7-21
7-10	Operator Control Valve Assembly	7-23
7-11	Front Handle Assembly	7-25
7-12	Sway Handle Assembly	7-27

Numerical List of Parts Breakdowns – Cont.

<u>Figure No.</u>	<u>Title</u>	<u>Page No.</u>
7-13	Rear Handle Assembly	7-29
7-14	Lift Cylinder Assembly	7-31
7-15	Extend Cylinder Assembly	7-33
7-16	Extend Cylinder Housing Assembly	7-35
7-17	Carriage Tilt Cylinder Assembly	7-37
7-18	Front Axle Cylinder Assembly	7-39
7-19	Rear Axle Cylinder Assembly	7-41
7-20	Rear Axle Lock Manifold Assembly	7-43
7-21	Boom Hose Kit	7-45
7-22	Chassis Hose Kit	7-47
8-1	Electrical Assembly	8-2
8-2	Electrical Center Assembly	8-7
8-3	Terminal Strip Assembly	8-9
8-4	Terminal Strip Assembly	8-11
8-5	Terminal Strip Assembly	8-13
8-6	Engine Relay Assembly	8-15
8-7	Battery Disconnect Switch Assembly	8-17
8-8	Fuse Block Assembly	8-19
8-9	Solenoid Assembly	8-21
9-1	Boom Assembly	9-2
9-2	Inner Boom Assembly	9-5
9-3	Outer Boom Assembly	9-11
9-4	Angle Indicator Assembly	9-16
9-5	Slide Block Assembly	9-18
9-6	Outer Boom Roller Assembly	9-20
9-7	Roller Assembly	9-22
9-8	Tube Clamp Assembly No. 2	9-24
9-9	Hose Clamp Assembly	9-26
10-1	Cab Assembly	10-2
10-2	Enclosed Cab Assembly	10-8
10-3	Front Control Console Assembly	10-10
10-4	Front Control Panel Assembly	10-13
10-5	Control Enclosure Subassembly	10-15
10-6	Side Control Console Assembly	10-18
10-7	Side Console Cover Assembly	10-21

Numerical List of Parts Breakdowns – Cont.

<u>Figure No.</u>	<u>Title</u>	<u>Page No.</u>
10-8	Accelerator Pedal Assembly.....	10-23
10-9	Front Cover Assembly	10-25
10-10	Engine Cover Assembly	10-28
10-11	Radiator Cover Assembly.....	10-31
10-12	Battery Cover Assembly.....	10-33
10-13	Rear Light Assembly	10-35
10-14	Radiator Shroud Assembly.....	10-37
10-15	Filler Plate Assembly.....	10-39
11-1	Standard Carriage Assembly.....	11-2
11-2	Adjustable Carriage Assembly	11-4

Section 1

General Information

Table 1-1. Abbreviations & Acronyms

<u>Term</u>	<u>Meaning</u>
A	Amperes
ASTM	American Society for Testing and Materials
AWG	American Wire Gauge
BHC	Button head cap
BKDN	Breakdown
DIA	Diameter
DPDT	Double-pole, double-throw
FSHC	Flat socket head cap
FTG	Fittings
HHC	Hex head cap
ID	Inside diameter
LG	Long
MM	Millimeter
NHA	Next higher assembly
NPT	National pipe thread
OD	Outside diameter
OHM	Oval head machine
PHM	Pan head machine
PWH	Pan washer head
QD	Quick-Disconnect
REF	Reference
REG	Regular
SAE	Society of Automotive Engineers
SBHC	Socket button head cap
SHC	Socket head cap
SHS	Socket head shoulder

<u>Term</u>	<u>Meaning</u>
SPDT	Single-throw, double-pole
SPST	Single-pole, single-throw
STR	Straight
THD	Thread
UNC	Unified National Coarse
UNF	Unified National Fine
V	Volts

Section 2

Chassis

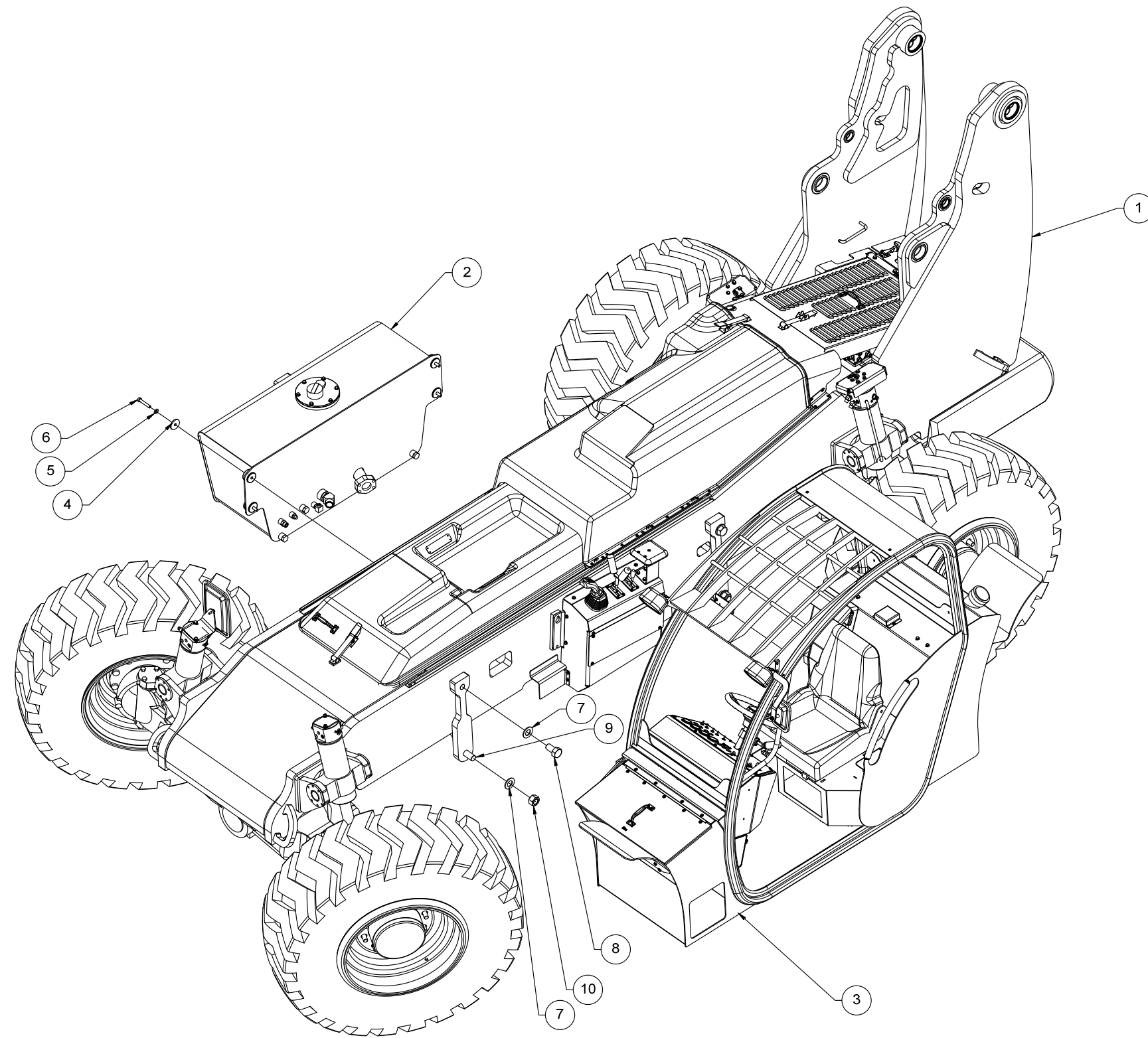

Figure 2-1. Basic Assembly

Table 2-1. Basic Assembly

Figure & Item No.	Part No.	Description	Quantity	Use On
–	27225-000	Basic assembly	1	–
2-1-1	27226-000	Chassis assembly – covers and console	1	–
2-1-2	26976-000	Hydraulic tank assembly	1	–
2-1-3	27410-000	Cab assembly	1	–
2-1-4	27121-000	Isolator retainer plate	4	–
2-1-5	11001-008	Washer 1/2 SAE flat	4	–
2-1-6	10004-024	Screw 1/2-13UNC HHC x 3	4	–
2-1-7	11001-020	Washer 1-1/4 SAE flat	6	–
2-1-8	10031-018	Screw 1-1/4-12UNF HHC x 2-1/4	2	–
2-1-9	10031-032	Screw 1-1/4-12UNF HHC x 4	2	–
2-1-10	10901-020	Hnut 1-1/4-12UNF	2	–

Refer to Section 1 for the definition of acronyms and abbreviations used in the Description Column.

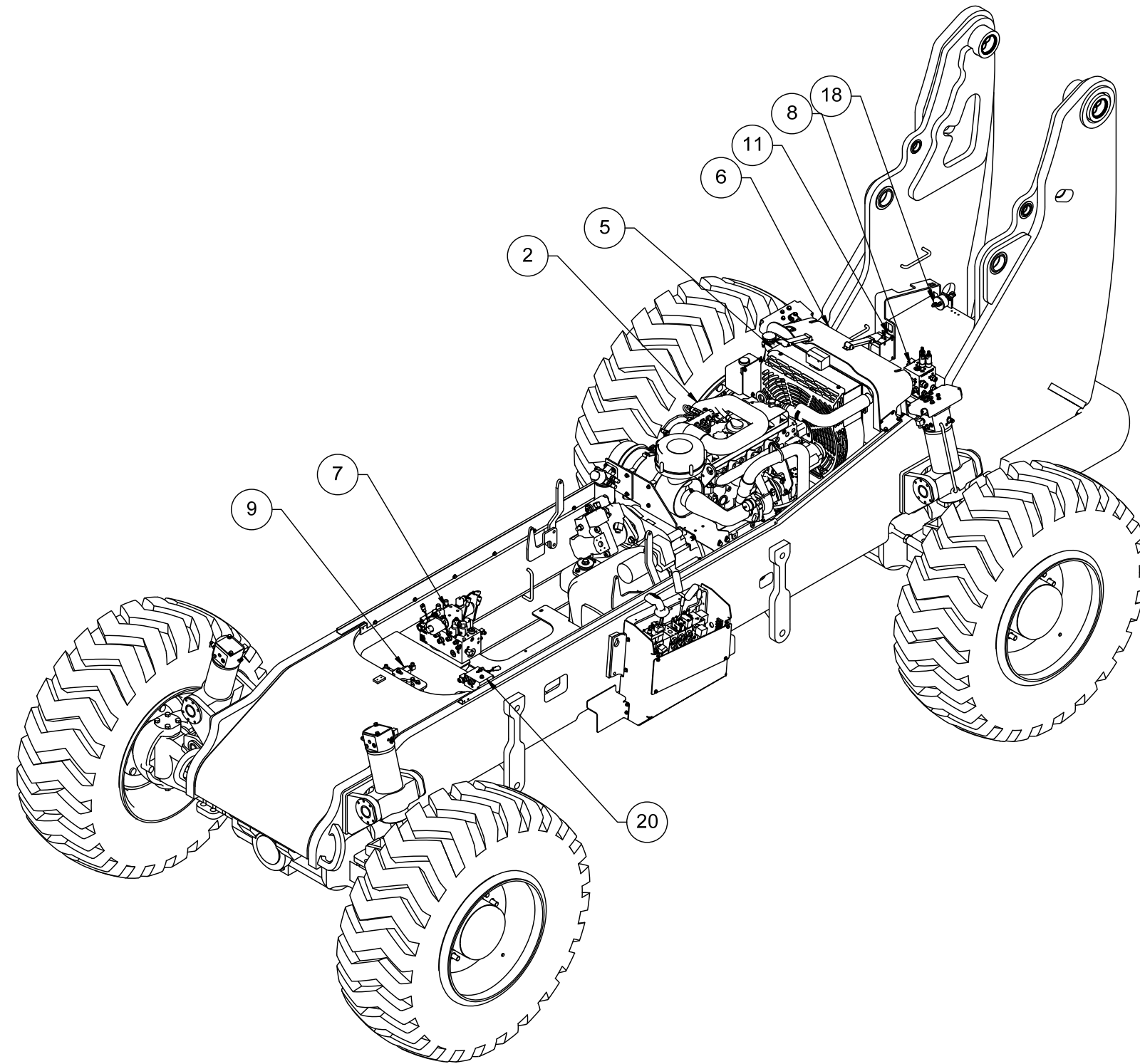

Figure 2-2. Chassis Assembly – Engine (Sheet 1 of 5)

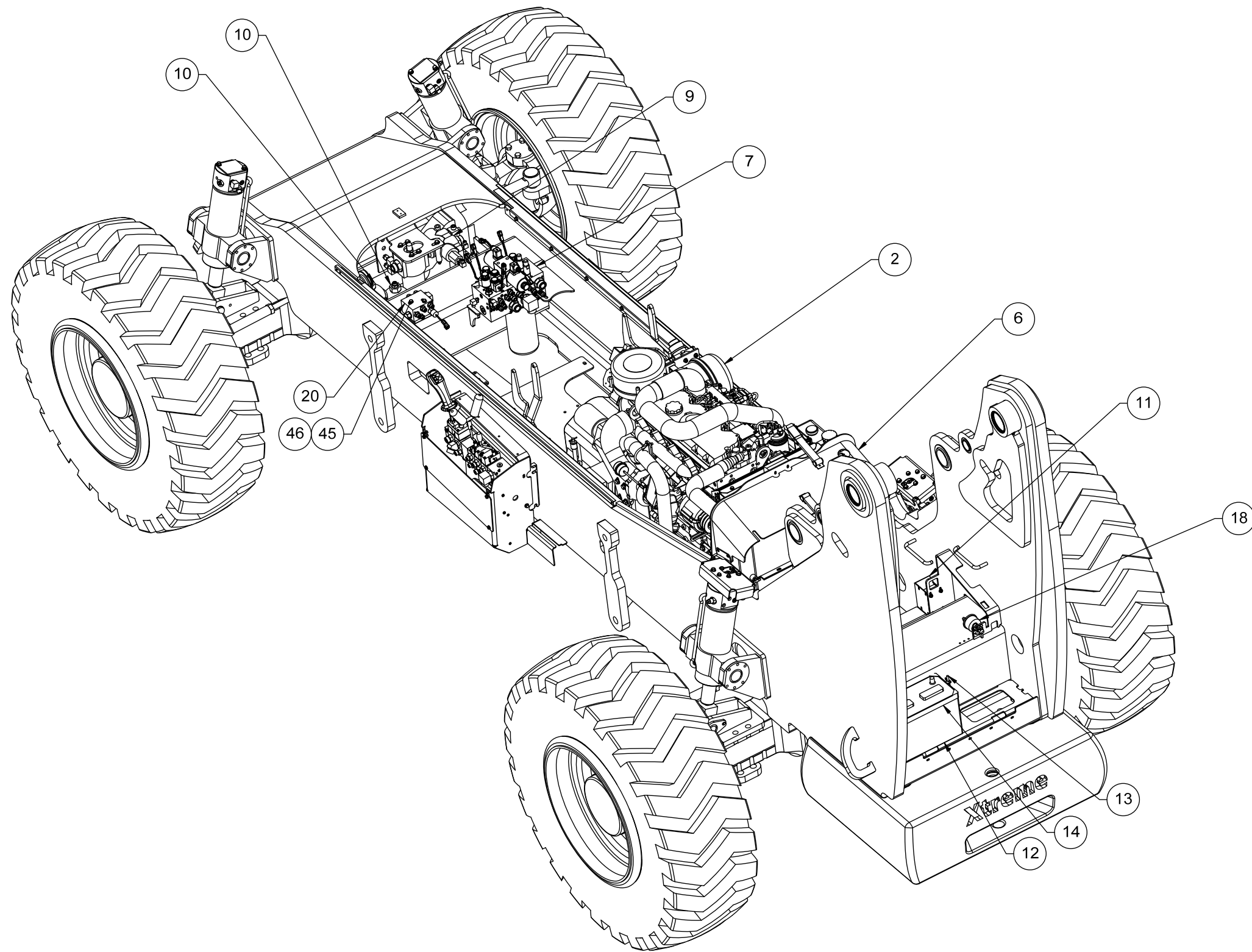

Figure 2-2. Chassis Assembly – Engine (Sheet 2 of 5)

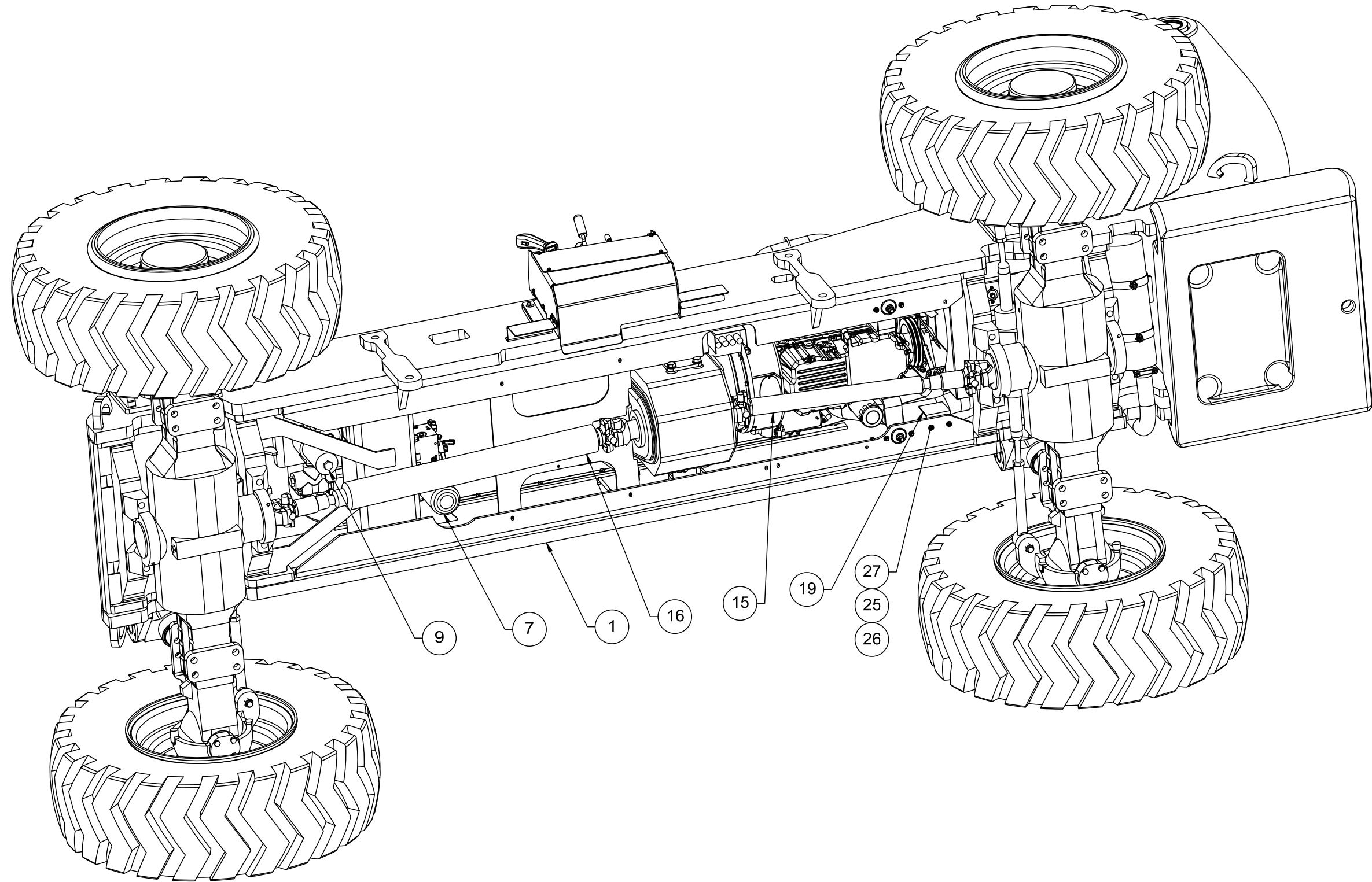

Figure 2-2. Chassis Assembly – Engine (Sheet 3 of 5)