

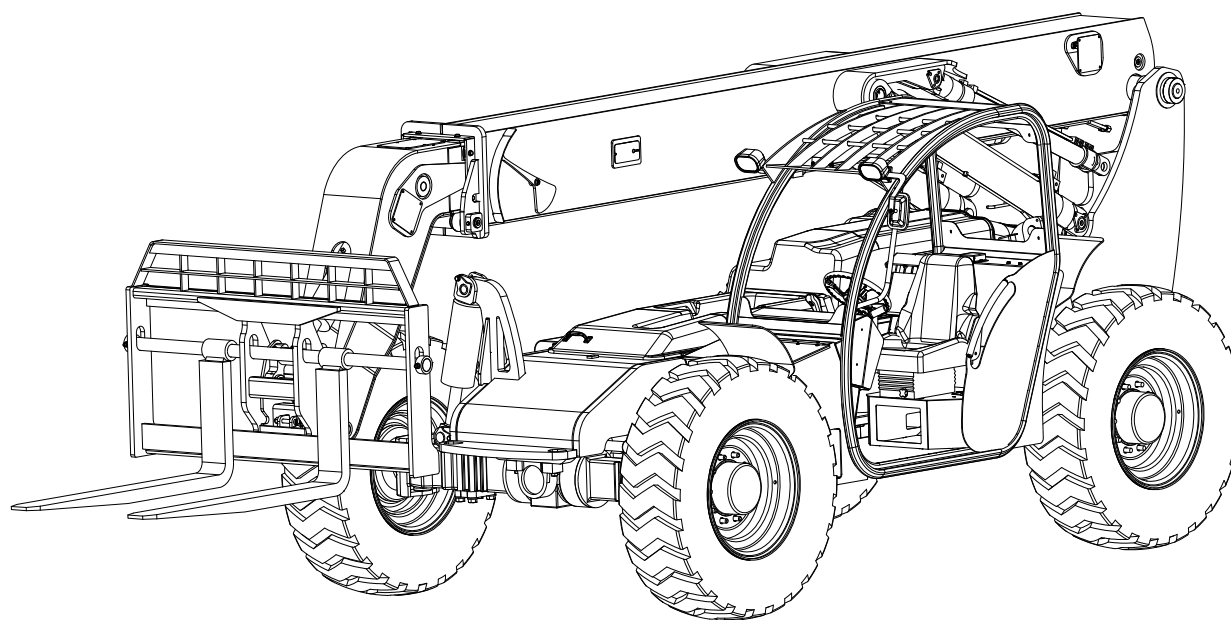

## **Illustrated Parts Breakdown Manual**

### **Forward Reach Forklift**

### **Model XR1534**



**Xtreme Manufacturing  
1415 West Bonanza Road  
Las Vegas, NV 89106  
(702) 636-2969  
[www.xtrememanufacturing.com](http://www.xtrememanufacturing.com)**

Copyright © 2009 By Xtreme Manufacturing

## List of Effective Pages

This manual consists of 348 pages as listed below:

- Outside title page
- Inside title page
- Pages A through D
- Pages i through x
- Pages 1-1 through 1-2
- Pages 2-1 through 2-24
- Pages 3-1 through 3-22
- Pages 4-1 through 4-16
- Pages 5-1 through 5-12
- Pages 6-1 through 6-14
- Pages 7-1 through 7-54
- Pages 8-1 through 8-22
- Pages 9-1 through 9-28
- Pages 10-1 through 10-46
- Pages 11-1 through 11-6
- Index 1 through Index 84
- Warranty 1 through Warranty 2
- Inside back cover
- Outside back cover





THIS PAGE INTENTIONALLY LEFT BLANK

## Table of Contents

<u>Chap./Par.</u>	<u>Title</u>	<u>Page</u>
	List of Effective Pages .....	A
	Service Bulletins .....	B
	Design Change Notices .....	C
	Alphabetical List of Parts Breakdowns .....	ii
	Numerical List of Parts Breakdowns .....	v
	Section 1 – General Information .....	1-1
	Section 2 – Chassis .....	2-1
	Section 3 – Labels and Load Charts .....	3-1
	Section 4 – Engine .....	4-1
	Section 5 – Transmission, Axles, and Driveshafts .....	5-1
	Section 6 – Steering, Brakes, Wheels, and Tires .....	6-1
	Section 7 – Hydraulic System .....	7-1
	Section 8 – Electrical System .....	8-1
	Section 9 – Boom .....	9-1
	Section 10 – Cab and Consoles .....	10-1
	Section 11 – Boom Attachments .....	11-1
	Numerical and Alphabetical Indexes .....	Index 1

## Alphabetical List of Parts Breakdowns

<u>Title</u>	<u>Figure No.</u>	<u>Page No.</u>
Accelerator Pedal Assembly .....	10-9.....	10-26
Accumulator Assembly.....	6-3.....	6-6
Adapter Assembly .....	9-5.....	9-15
Air Cleaner Assembly.....	4-4.....	4-12
Angle Indicator Assembly.....	9-4.....	9-13
Axle Cylinder Subassembly .....	7-22.....	7-47
Basic Assembly .....	2-1.....	2-2
Battery Cover Assembly.....	10-13.....	10-36
Battery Disconnect Switch Assembly.....	8-7.....	8-16
Belleville Spring Stack.....	9-9.....	9-23
Boom Assembly .....	9-1.....	9-2
Boom Hose Kit .....	7-23.....	7-49
Boom Manifold Assembly.....	7-7.....	7-17
Brake Charge Valve Assembly .....	6-4.....	6-8
Brake Pressure Switch Assembly .....	6-5.....	6-11
Brake Valve Assembly .....	6-2.....	6-4
Cab Assembly .....	10-1.....	10-2
Carriage Pin Assembly.....	11-2.....	11-4
Carriage Tilt Cylinder Assembly.....	7-17.....	7-37
Carriage Tilt Cylinder Subassembly.....	7-18.....	7-39
Chassis Assembly – Axles .....	2-4.....	2-12
Chassis Assembly – Covers & Console.....	2-5.....	2-19
Chassis Assembly – Engine.....	2-3.....	2-6
Chassis Hose Kit.....	7-24.....	7-51
Console Roller Assembly .....	10-17.....	10-44
Control Enclosure Subassembly .....	10-5.....	10-17
Distribution Manifold Assembly .....	7-5.....	7-8
Electrical Assembly .....	8-1.....	8-2
Electrical Center Assembly .....	8-2.....	8-6
Enclosed Cab Assembly .....	10-2.....	10-7
Engine Cover Assembly .....	10-11.....	10-31
Engine Relay Assembly .....	8-6.....	8-14
Engine Transmission Assembly .....	4-1.....	4-2
Extend Cylinder Assembly .....	7-13.....	7-29

## Alphabetical List of Parts Breakdowns – Cont.

<u>Title</u>	<u>Figure No.</u>	<u>Page No.</u>
Extend Cylinder Collar Assembly.....	7-15.....	7-33
Extend Cylinder Housing Assembly.....	7-14.....	7-31
Extend Cylinder Pin Assembly.....	7-16.....	7-35
Filler Plate Assembly.....	10-16.....	10-42
Final Assembly.....	2-2.....	2-4
Front Axle Assembly.....	5-2.....	5-5
Front Axle Cylinder Assembly.....	7-19.....	7-41
Front Control Console Assembly.....	10-3.....	10-11
Front Control Panel Assembly.....	10-4.....	10-14
Front Cover Assembly.....	10-10.....	10-28
Front Driveshaft Assembly.....	5-4.....	5-9
Front Handle Assembly.....	7-9.....	7-21
Fuel Tank Assembly.....	4-5.....	4-14
Fuse Block Assembly.....	8-8.....	8-18
High-Pressure Filter/Steering Valve Assembly.....	7-4.....	7-8
Hose Clamp Assembly.....	9-11.....	9-27
Hydraulic Tank Assembly.....	7-1.....	7-2
Hydraulic Tank Lid Assembly.....	7-2.....	7-4
Inner Boom Assembly.....	9-2.....	9-6
Isolation Manifold Assembly.....	7-6.....	7-14
Labels and Load Charts.....	3-1.....	3-2
Lift Cylinder Assembly.....	7-12.....	7-27
Master Cylinder Assembly.....	7-3.....	7-6
Operator Control Valve Assembly.....	7-8.....	7-19
Outer Boom Assembly.....	9-3.....	9-11
Outer Boom Roller Assembly.....	9-7.....	9-19
Overflow Tank Assembly.....	4-3.....	4-10
Radiator Assembly.....	4-2.....	4-7
Radiator Cover Assembly.....	10-12.....	10-34
Radiator Shroud Assembly.....	10-15.....	10-40
Rear Axle Assembly.....	5-3.....	5-7
Rear Axle Cylinder Assembly.....	7-20.....	7-43
Rear Axle Lock Manifold Assembly.....	7-21.....	7-45
Rear Driveshaft Assembly.....	5-5.....	5-11



## Alphabetical List of Parts Breakdowns – Cont.

<u>Title</u>	<u>Figure No.</u>	<u>Page No.</u>
Rear Handle Assembly .....	7-11.....	7-25
Rear Light Assembly .....	10-14.....	10-38
Roller Assembly .....	9-8.....	9-21
Side Console Cover Assembly .....	10-7.....	10-22
Side Console Subassembly .....	10-8.....	10-24
Side Control Console Assembly .....	10-6.....	10-20
Slide Block Assembly.....	9-6.....	9-17
Solenoid Assembly.....	8-9.....	8-20
Standard Carriage Assembly .....	11-1.....	11-2
Steering Column Assembly.....	6-1.....	6-2
Sway Handle Assembly .....	7-10.....	7-23
Terminal Strip Assembly .....	8-3.....	8-8
Terminal Strip Assembly .....	8-4.....	8-10
Terminal Strip Assembly .....	8-5.....	8-12
Transmission and Pump Assembly.....	5-1.....	5-2
Tube Clamp Assembly No. 2 .....	9-10.....	9-25
Wheel Tire Assembly .....	6-6.....	6-13

## Numerical List of Parts Breakdowns

<u>Figure No.</u>	<u>Title</u>	<u>Page No.</u>
2-1	Basic Assembly	2-2
2-2	Final Assembly	2-4
2-3	Chassis Assembly – Engine	2-6
2-4	Chassis Assembly – Axles	2-12
2-5	Chassis Assembly – Covers & Console	2-19
3-1	Labels and Load Charts	3-2
4-1	Engine Transmission Assembly	4-2
4-2	Radiator Assembly	4-7
4-3	Overflow Tank Assembly	4-10
4-4	Air Cleaner Assembly	4-12
4-5	Fuel Tank Assembly	4-14
5-1	Transmission and Pump Assembly	5-2
5-2	Front Axle Assembly	5-5
5-3	Rear Axle Assembly	5-7
5-4	Front Driveshaft Assembly	5-9
5-5	Rear Driveshaft Assembly	5-11
6-1	Steering Column Assembly	6-2
6-2	Brake Charge Valve Assembly	6-4
6-3	Accumulator Assembly	6-6
6-4	Brake Charge Valve Assembly	6-8
6-5	Brake Pressure Switch Assembly	6-11
6-6	Wheel Tire Assembly	6-13
7-1	Hydraulic Tank Assembly	7-2
7-2	Hydraulic Tank Lid Assembly	7-4
7-3	Master Cylinder Assembly	7-6
7-4	High-Pressure Filter/Steering Valve Assembly	7-8
7-5	Distribution Manifold Assembly	7-10
7-6	Isolation Manifold Assembly	7-14
7-7	Boom Manifold Assembly	7-17
7-8	Operator Control Valve Assembly	7-19
7-9	Front Handle Assembly	7-21
7-10	Sway Handle Assembly	7-23
7-11	Rear Handle Assembly	7-25

## Numerical List of Parts Breakdowns – Cont.

<u>Figure No.</u>	<u>Title</u>	<u>Page No.</u>
7-12	Lift Cylinder Assembly .....	7-27
7-13	Extend Cylinder Assembly.....	7-29
7-14	Extend Cylinder Housing Assembly .....	7-31
7-15	Extend Cylinder Collar Assembly .....	7-33
7-16	Extend Cylinder Pin Assembly .....	7-35
7-17	Carriage Tilt Cylinder Assembly .....	7-37
7-18	Carriage Tilt Cylinder Subassembly .....	7-39
7-19	Front Axle Cylinder Assembly .....	7-41
7-20	Rear Axle Cylinder Assembly .....	7-43
7-21	Rear Axle Lock Manifold Assembly .....	7-45
7-22	Axle Cylinder Subassembly.....	7-47
7-23	Boom Hose Kit.....	7-49
7-24	Chassis Hose Kit .....	7-51
8-1	Electrical Assembly .....	8-2
8-2	Electrical Center Assembly.....	8-6
8-3	Terminal Strip Assembly.....	8-8
8-4	Terminal Strip Assembly.....	8-10
8-5	Terminal Strip Assembly.....	8-12
8-6	Engine Relay Assembly.....	8-14
8-7	Battery Disconnect Switch Assembly .....	8-16
8-8	Fuse Block Assembly .....	8-18
8-9	Solenoid Assembly .....	8-20
9-1	Boom Assembly.....	9-2
9-2	Inner Boom Assembly .....	9-6
9-3	Outer Boom Assembly.....	9-11
9-4	Angle Indicator Assembly .....	9-13
9-5	Adapter Assembly .....	9-15
9-6	Slide Block Assembly .....	9-17
9-7	Outer Boom Roller Assembly .....	9-19
9-8	Roller Assembly.....	9-21
9-9	Belleville Spring Stack .....	9-23
9-10	Tube Clamp Assembly No. 2.....	9-25
9-11	Hose Clamp Assembly .....	9-27

## Numerical List of Parts Breakdowns – Cont.

<u>Figure No.</u>	<u>Title</u>	<u>Page No.</u>
10-1	Cab Assembly.....	10-2
10-2	Enclosed Cab Assembly.....	10-7
10-3	Front Control Console Assembly.....	10-11
10-4	Front Control Panel Assembly.....	10-14
10-5	Control Enclosure Subassembly .....	10-17
10-6	Side Control Console Assembly .....	10-20
10-7	Side Console Cover Assembly .....	10-22
10-8	Side Console Subassembly.....	10-24
10-9	Accelerator Pedal Assembly.....	10-26
10-10	Front Cover Assembly .....	10-28
10-11	Engine Cover Assembly .....	10-31
10-12	Radiator Cover Assembly.....	10-34
10-13	Battery Cover Assembly .....	10-36
10-14	Rear Light Assembly .....	10-38
10-15	Radiator Shroud Assembly.....	10-40
10-16	Filler Plate Assembly .....	10-42
10-17	Console Roller Assembly .....	10-44
11-1	Standard Carriage Assembly.....	11-2
11-2	Carriage Pin Assembly .....	11-4

# Section 1

## General Information

**Table 1-1. Abbreviations & Acronyms**

<u>Term</u>	<u>Meaning</u>
A	Amperes
ASTM	American Society for Testing and Materials
AWG	American Wire Gauge
BHC	Button head cap
BKDN	Breakdown
DIA	Diameter
DPDT	Double-pole, double-throw
FSHC	Flat socket head cap
FTG	Fittings
HHC	Hex head cap
ID	Inside diameter
LG	Long
MM	Millimeter
NHA	Next higher assembly
NPT	National pipe thread
OD	Outside diameter
OHM	Oval head machine
PHM	Pan head machine
PWH	Pan washer head
QD	Quick-Disconnect
REF	Reference
REG	Regular
SAE	Society of Automotive Engineers
SBHC	Socket button head cap
SHC	Socket head cap
SHS	Socket head shoulder

<b><u>Term</u></b>	<b><u>Meaning</u></b>
SPDT	Single-throw, double-pole
SPST	Single-pole, single-throw
STR	Straight
THD	Thread
UNC	Unified National Coarse
UNF	Unified National Fine
V	Volts

## **Section 2**

### **Chassis**

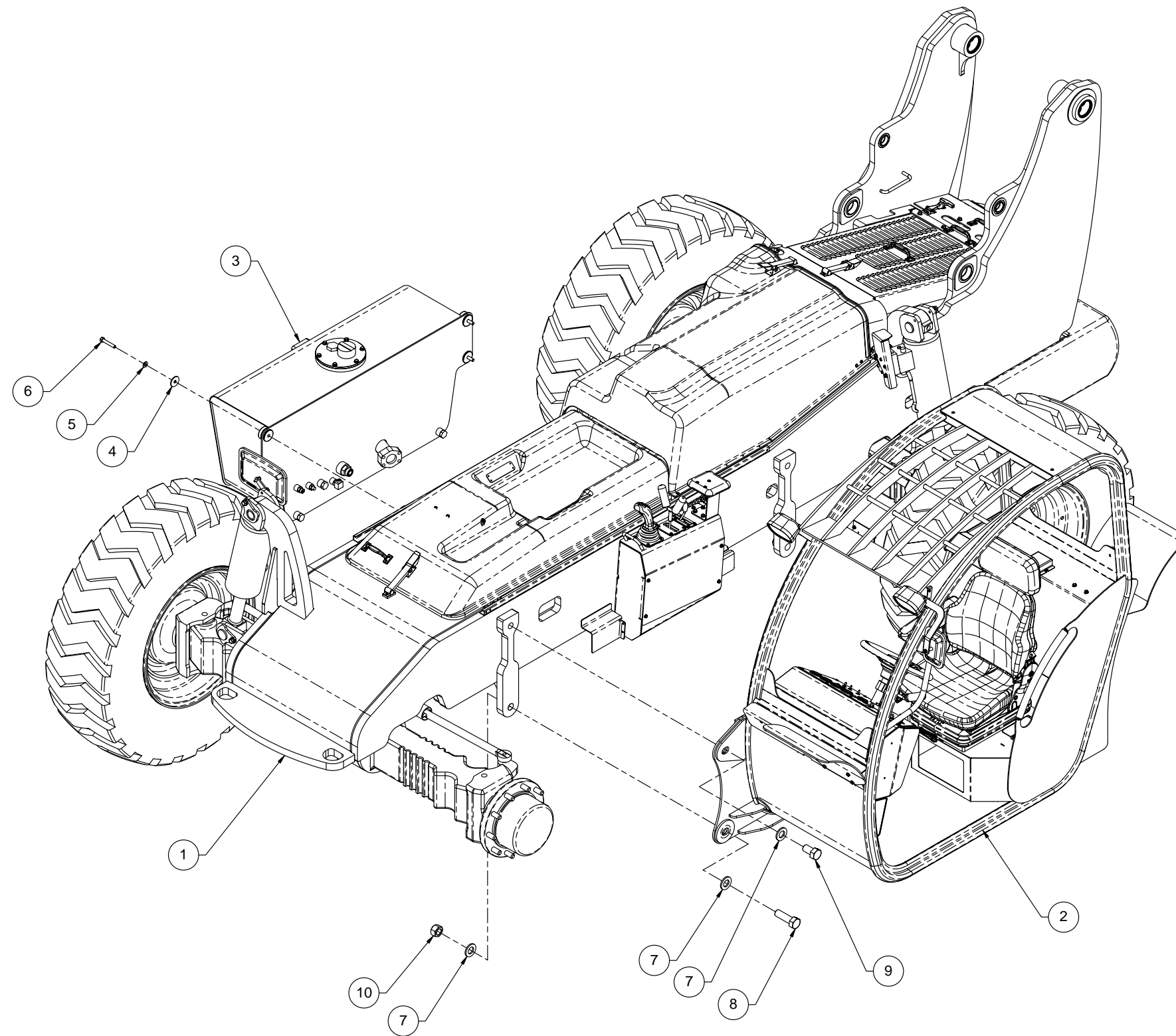

Figure 2-1. Basic Assembly



Table 2-1. Basic Assembly

Figure & Item No.	Part No.	Description	Quantity	Use On
–	27906-000	Basic Assembly	1	–
2-1-1	27907-000	Chassis assembly – covers & console	1	–
2-1-2	27436-000	Cab assembly	1	–
2-1-3	26641-001	Hydraulic tank assembly	1	–
2-1-4	25383-000	Pin retainer plate	4	–
2-1-5	11001-008	Washer 1/2 SAE flat	4	–
2-1-6	10004-024	Screw 1/2-13UNC HHC x 3	4	–
2-1-7	11002-020	Extra thick grade 8 SAE washer	6	–
2-1-8	10031-032	Screw 1-1/4-12UNF HHC x 4	2	–
2-1-9	10031-018	Screw 1-1/4-12UNF HHC x 2-1/4	2	–
2-1-10	10901-020	Nut 1-1/4-12UNF reg hex	2	–

Refer to Section 1 for the definition of acronyms and abbreviations used in the Description Column.

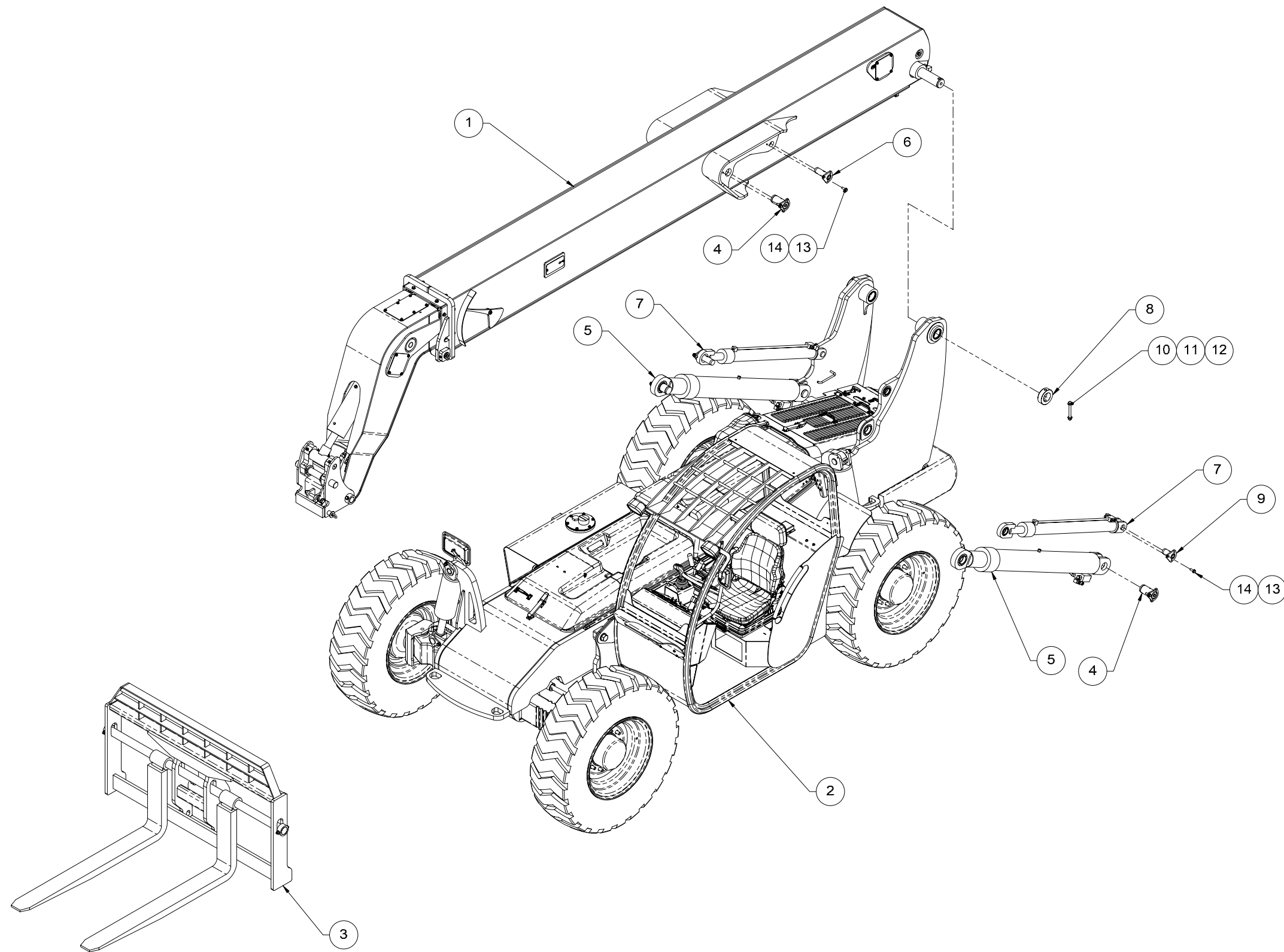

Figure 2-2. Final Assembly

**Table 2-2. Final Assembly**

<b>Figure &amp; Item No.</b>	<b>Part No.</b>	<b>Description</b>	<b>Quantity</b>	<b>Use On</b>
–	27905-000	Final Assembly	–	–
2-2-1	27915-000	Boom assembly	1	–
2-2-2	27906-000	Basic assembly	1	–
2-2-3	27912-000	Carriage assembly	1	–
2-2-4	27075-000	Lift cylinder pin assembly	4	–
2-2-5	26594-000	Lift cylinder assembly	2	–
2-2-6	27062-000	Master cylinder pin assembly	2	–
2-2-7	26321-000	Master cylinder assembly	2	–
2-2-8	25625-000	Shaft collar	2	–
2-2-9	27064-000	Master cylinder pin assembly	2	–
2-2-10	11001-010	Washer 5/8SAE flat	4	–
2-2-11	10006-048	Screw 5/8-11UNC HHC x 6	2	–
2-2-12	10900-010	Nut 5/8-11UNC reg hex	2	–
2-2-13	11001-008	Washer 1/2 SAE flat	8	–
2-2-14	10004-012	Bolt 1/2-13UNC x 1.5	8	–

Refer to Section 1 for the definition of acronyms and abbreviations used in the Description Column.

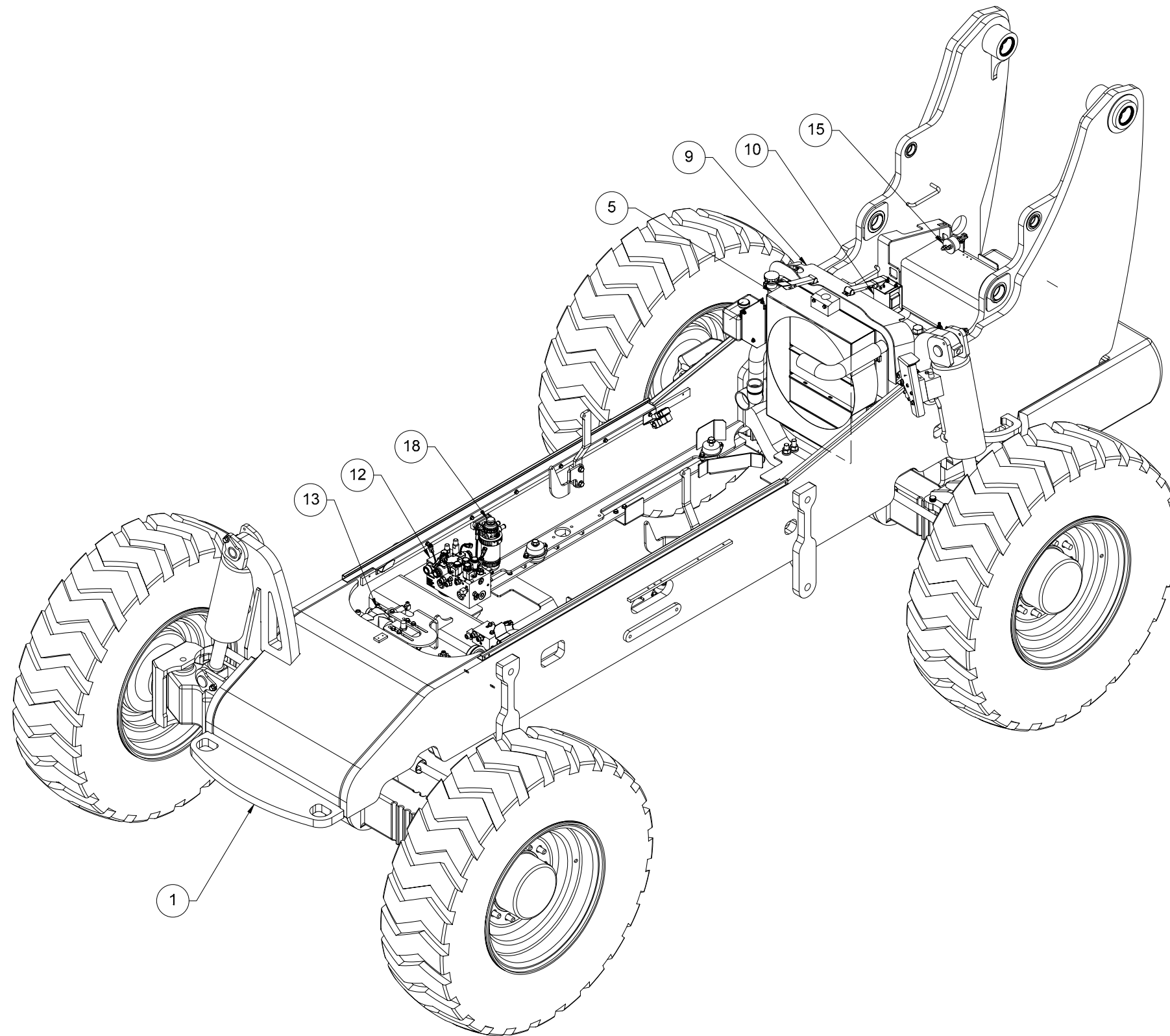

Figure 2-3. Chassis Assembly – Engine (Sheet 1 of 4)