

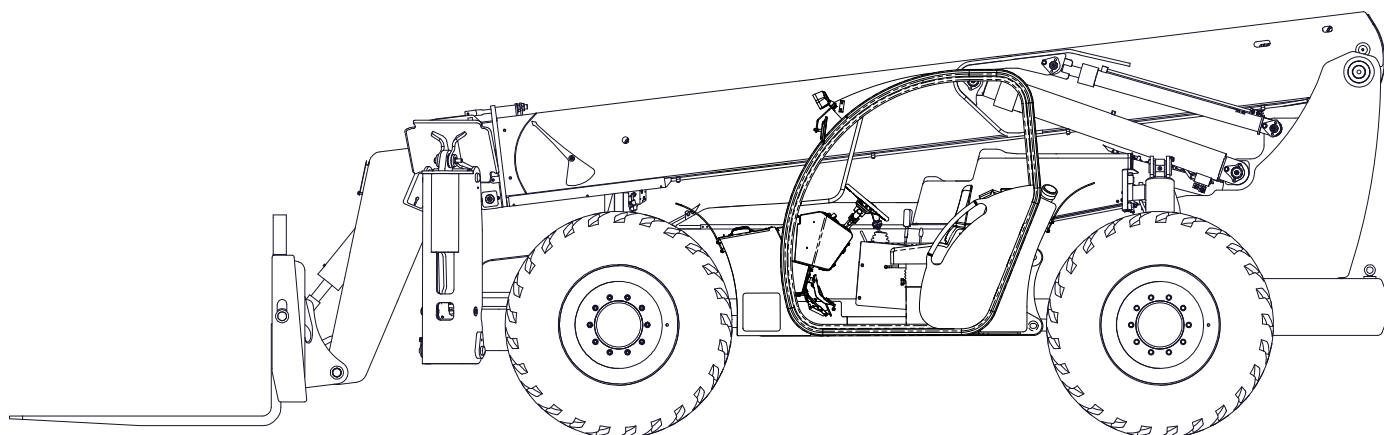

## Illustrated Parts Breakdown Manual

### Forward Reach Forklift Model XR1245/1254 (Tier III)



**Xtreme Manufacturing**  
**1415 West Bonanza Road**  
**Las Vegas, NV 89106**  
**(702) 858-2404**  
**[www.xtrememanufacturing.com](http://www.xtrememanufacturing.com)**

Copyright © 2008 By Xtreme Manufacturing

## List of Effective Pages

This manual consists of 527 pages as listed below:

- Outside title page
- Inside title page
- Pages A through D
- Pages i through x
- Pages 1-1 through 1-2
- Pages 2-1 through 2-46
- Pages 3-1 through 3-20
- Pages 4-1 through 4-18
- Pages 5-1 through 5-16
- Pages 6-1 through 6-16
- Pages 7-1 through 7-82
- Pages 8-1 through 8-22
- Pages 9-1 through 9-74
- Pages 10-1 through 10-56
- Pages 11-1 through 11-12
- Index 1 through Index 144
- Warranty 1 through Warranty 2
- Inside back cover
- Outside back cover

## Service Bulletins

The following service bulletins have been incorporated in this manual:

Title	Bulletin No.	Comments

# Design Change Notices

The following design change notices have been incorporated in this manual:

Title	Design Change Notice No.	Comments

THIS PAGE INTENTIONALLY LEFT BLANK

## Table of Contents

<u>Chap./Par.</u>	<u>Title</u>	<u>Page</u>
	List of Effective Pages .....	A
	Service Bulletins .....	B
	Design Change Notices .....	C
	Alphabetical List of Parts Breakdowns .....	ii
	Numerical List of Parts Breakdowns .....	v
	Section 1 – General Information .....	1-1
	Section 2 – Chassis .....	2-1
	Section 3 – Labels and Load Charts .....	3-1
	Section 4 – Engine .....	4-1
	Section 5 – Transmission, Axles, and Driveshafts .....	5-1
	Section 6 – Steering, Brakes, Wheels, and Tires .....	6-1
	Section 7 – Hydraulic System .....	7-1
	Section 8 – Electrical System .....	8-1
	Section 9 – Boom .....	9-1
	Section 10 – Cab and Consoles .....	10-1
	Section 11 – Boom Attachments .....	11-1
	Numerical and Alphabetical Indexes .....	Index 1

## Alphabetical List of Parts Breakdowns

<u>Title</u>	<u>Figure No.</u>	<u>Page No.</u>
1245 Basic Assembly.....	2-1.....	2-2
1245 Boom Assembly .....	9-1.....	9-2
1245 Boom Hose Kit .....	7-33.....	7-70
1245 Cab Assembly .....	10-1.....	10-2
1245 Chassis Assembly – Axles .....	2-7.....	2-23
1245 Chassis Assembly – Covers & Console.....	2-9.....	2-37
1245 Chassis Assembly – Engine .....	2-5.....	2-10
1245 Chassis Hose Kit.....	7-35.....	7-74
1245 Extend Cylinder Assembly .....	7-15.....	7-33
1245 Extend Cylinder Housing Assembly .....	7-17.....	7-37
1245 Extend Cylinder Support Assembly .....	7-19.....	7-41
1245 Final Assembly.....	2-3.....	2-6
1245 Front Driveshaft Assembly .....	5-5.....	5-11
1245 Fuel Tank Assembly.....	4-5.....	4-14
1245 Inner Boom Assembly .....	9-7.....	9-32
1245 Inner Boom Subassembly .....	9-9.....	9-38
1245 Inner Boom Subassembly .....	9-11.....	9-44
1245 Lift Cylinder Assembly.....	7-13.....	7-29
1245 Mid Boom Assembly .....	9-5.....	9-20
1245 Operator Control Valve Assembly.....	7-8.....	7-19
1245 Outer Boom Assembly .....	9-3.....	9-12
1245 Outrigger Mount Assembly .....	7-29.....	7-61
1245 Side Control Console Assembly .....	10-7.....	10-24
1245 Wheel Tire Assembly .....	6-6.....	6-12
1254 Basic Assembly.....	2-2.....	2-4
1254 Boom Assembly .....	9-2.....	9-7
1254 Boom Hose Kit .....	7-34.....	7-72
1254 Cab Assembly .....	10-2.....	10-7
1254 Chassis Assembly – Axles .....	2-8.....	2-30
1254 Chassis Assembly – Covers & Console.....	2-10.....	2-42
1254 Chassis Assembly – Engine .....	2-6.....	2-16
1254 Chassis Hose Kit.....	7-36.....	7-78
1254 Extend Cylinder Assembly .....	7-16.....	7-35

## Alphabetical List of Parts Breakdowns – Cont.

<u>Title</u>	<u>Figure No.</u>	<u>Page No.</u>
1254 Extend Cylinder Housing Assembly .....	7-18.....	7-39
1254 Extend Cylinder Support Assembly .....	7-20.....	7-43
1254 Final Assembly .....	2-4.....	2-8
1254 Front Driveshaft Assembly .....	5-6.....	5-13
1254 Fuel Tank Assembly .....	4-6.....	4-16
1254 Inner Boom Assembly .....	9-8.....	9-35
1254 Inner Boom Subassembly .....	9-10.....	9-41
1254 Inner Boom Subassembly .....	9-12.....	9-46
1254 Lift Cylinder Assembly .....	7-14.....	7-31
1254 Mid Boom Assembly .....	9-6.....	9-26
1254 Operator Control Valve Assembly .....	7-9.....	7-21
1254 Outer Boom Assembly .....	9-4.....	9-16
1254 Outrigger Mount Assembly .....	7-30.....	7-64
1254 Side Control Console Assembly .....	10-8.....	10-26
1254 Wheel Tire Assembly .....	6-7.....	6-14
Accelerator Pedal Assembly .....	10-12.....	10-36
Accumulator Assembly .....	6-3.....	6-6
Accumulator Charge Valve Assembly .....	6-4.....	6-8
Adapter Assembly .....	9-14.....	9-50
Air Cleaner Assembly .....	4-4.....	4-12
Angle Indicator Assembly .....	9-13.....	9-48
Axle Cylinder Subassembly .....	7-28.....	7-59
Battery Cover Assembly .....	10-16.....	10-46
Battery Disconnect Switch Assembly .....	8-7.....	8-17
Belleville Spring Stack .....	9-23.....	9-68
Boom Manifold Assembly .....	7-7.....	7-17
Brake Pressure Switch Assembly .....	6-5.....	6-10
Brake Valve Assembly .....	6-2.....	6-4
Carriage Pin Assembly .....	11-5.....	11-10
Carriage Post Assembly .....	11-4.....	11-8
Carriage Tilt Cylinder Assembly .....	7-23.....	7-49
Chain Sheave Assembly .....	9-21.....	9-64
Chain Sheave Assembly .....	9-22.....	9-66
Console Roller Assembly .....	10-20.....	10-54



## Alphabetical List of Parts Breakdowns – Cont.

<u>Title</u>	<u>Figure No.</u>	<u>Page No.</u>
Control Enclosure Subassembly .....	10-6.....	10-21
Dipstick Tube Assembly .....	5-2.....	5-5
Distribution Manifold Assembly .....	7-5.....	7-10
Electrical Assembly .....	8-1.....	8-2
Electrical Center Assembly .....	8-2.....	8-7
Engine Cover Assembly .....	10-14.....	10-41
Engine Relay Assembly .....	8-6.....	8-15
Enclosed Cab Assembly .....	10-3.....	10-12
Engine Transmission Assembly .....	4-1.....	4-2
Extend Cylinder Collar Assembly .....	7-21.....	7-45
Extend Cylinder Pin Assembly .....	7-22.....	7-47
Filler Plate Assembly .....	10-19.....	10-52
Front Axle Assembly .....	5-3.....	5-7
Front Axle Cylinder Assembly .....	7-25.....	7-53
Front Control Console Assembly .....	10-4.....	10-16
Front Control Panel Assembly .....	10-5.....	10-19
Front Cover Assembly .....	10-13.....	10-38
Front Handle Assembly .....	7-10.....	7-23
Fuse Block Assembly .....	8-8.....	8-19
Handle Boot Assembly .....	10-11.....	10-34
High-Pressure Filter/Steering Valve Assembly .....	7-4.....	7-8
Hose Clamp Assembly .....	9-25.....	9-72
Hydraulic Tank Assembly .....	7-1.....	7-2
Hydraulic Tank Lid Assembly .....	7-2.....	7-4
Isolation Manifold Assembly .....	7-6.....	7-14
Labels and Load Charts .....	3-1.....	3-2
Master Cylinder Assembly .....	7-3.....	7-6
Mid Boom Roller Assembly .....	9-17.....	9-56
Optional Carriage Assembly .....	11-2.....	11-4
Outer Boom Roller Assembly .....	9-16.....	9-54
Outrigger Cylinder Assembly .....	7-31.....	7-66
Outrigger Cylinder Assembly .....	7-32.....	7-68
Overflow Tank Assembly .....	4-3.....	4-10
Radiator Assembly .....	4-2.....	4-7

## Alphabetical List of Parts Breakdowns – Cont.

<u>Title</u>	<u>Figure No.</u>	<u>Page No.</u>
Radiator Cover Assembly .....	10-15.....	10-44
Radiator Shroud Assembly .....	10-18.....	10-50
Rear Axle Assembly .....	5-4.....	5-9
Rear Axle Cylinder Assembly.....	7-26.....	7-55
Rear Axle Lock Manifold Assembly .....	7-27.....	7-57
Rear Driveshaft Assembly.....	5-7.....	5-15
Rear Handle Assembly .....	7-12.....	7-27
Rear Light Assembly .....	10-17.....	10-48
Roller Assembly .....	9-18.....	9-58
Roller Assembly .....	9-19.....	9-60
Roller Assembly .....	9-20.....	9-62
Rotate Carriage Assembly .....	11-3.....	11-6
Side Console Cover Assembly .....	10-9.....	10-30
Side Console Subassembly .....	10-10.....	10-32
Slide Block Assembly.....	9-15.....	9-52
Solenoid Assembly.....	8-9.....	8-21
Standard Carriage Assembly .....	11-1.....	11-2
Steering Column Assembly.....	6-1.....	6-2
Sway Handle Assembly .....	7-11.....	7-25
Terminal Strip Assembly .....	8-3.....	8-9
Terminal Strip Assembly .....	8-4.....	8-11
Terminal Strip Assembly .....	8-5.....	8-13
Tilt Cylinder Subassembly.....	7-24.....	7-51
Transmission and Pump Assembly.....	5-1.....	5-2
Tube Clamp Assembly No. 2 .....	9-24.....	9-70

## Numerical List of Parts Breakdowns

<u>Figure No.</u>	<u>Title</u>	<u>Page No.</u>
2-1	1245 Basic Assembly	2-2
2-2	1254 Basic Assembly	2-4
2-3	1245 Final Assembly	2-6
2-4	1254 Final Assembly	2-8
2-5	1245 Chassis Assembly – Engine	2-10
2-6	1254 Chassis Assembly – Engine	2-16
2-7	1245 Chassis Assembly – Axles	2-23
2-8	1254 Chassis Assembly – Axles	2-30
2-9	1245 Chassis Assembly – Covers & Console	2-37
2-10	1254 Chassis Assembly – Covers & Console	2-42
3-1	Decals and Load Charts	3-2
4-1	Engine Transmission Assembly	4-2
4-2	Radiator Assembly	4-7
4-3	Overflow Tank Assembly	4-10
4-4	Air Cleaner Assembly	4-12
4-5	1245 Fuel Tank Assembly	4-14
4-6	1254 Fuel Tank Assembly	4-16
5-1	Transmission and Pump Assembly	5-2
5-2	Dipstick Tube Assembly	5-5
5-3	Front Axle Assembly	5-7
5-4	Rear Axle Assembly	5-9
5-5	1245 Front Driveshaft Assembly	5-11
5-6	1254 Front Driveshaft Assembly	5-13
5-7	Rear Driveshaft Assembly	5-15
6-1	Steering Column Assembly	6-2
6-2	Brake Valve Assembly	6-4
6-3	Accumulator Assembly	6-6
6-4	Accumulator Charge Valve Assembly	6-8
6-5	Brake Pressure Switch Assembly	6-10
6-6	1245 Wheel Tire Assembly	6-12
6-7	1254 Wheel Tire Assembly	6-14
7-1	Hydraulic Tank Assembly	7-2

## Numerical List of Parts Breakdowns – Cont.

<u>Figure No.</u>	<u>Title</u>	<u>Page No.</u>
7-2	Hydraulic Tank Lid Assembly	7-4
7-3	Master Cylinder Assembly	7-6
7-4	High-Pressure Filter/Steering Valve Assembly	7-8
7-5	Distribution Manifold Assembly	7-10
7-6	Isolation Manifold Assembly	7-14
7-7	Boom Manifold Assembly	7-17
7-8	1245 Operator Control Valve Assembly	7-19
7-9	1254 Operator Control Valve Assembly	7-21
7-10	Front Handle Assembly	7-23
7-11	Sway Handle Assembly	7-25
7-12	Rear Handle Assembly	7-27
7-13	1245 Lift Cylinder Assembly	7-29
7-14	1254 Lift Cylinder Assembly	7-31
7-15	1245 Extend Cylinder Assembly	7-33
7-16	1254 Extend Cylinder Assembly	7-35
7-17	1245 Extend Cylinder Housing Assembly	7-37
7-18	1254 Extend Cylinder Housing Assembly	7-39
7-19	1245 Extend Cylinder Support Assembly	7-41
7-20	1254 Extend Cylinder Support Assembly	7-43
7-21	Extend Cylinder Collar Assembly	7-45
7-22	Extend Cylinder Pin Assembly	7-47
7-23	Carriage Tilt Cylinder Assembly	7-49
7-24	Tilt Cylinder Subassembly	7-51
7-25	Front Axle Cylinder Assembly	7-53
7-26	Rear Axle Cylinder Assembly	7-55
7-27	Rear Axle Lock Manifold Assembly	7-57
7-28	Axle Cylinder Subassembly	7-59
7-29	1245 Outrigger Mount Assembly	7-61
7-30	1254 Outrigger Mount Assembly	7-64
7-31	Outrigger Cylinder Assembly	7-66
7-32	Outrigger Cylinder Assembly	7-68
7-33	1245 Boom Hose Kit	7-70
7-34	1254 Boom Hose Kit	7-72
7-35	1245 Chassis Hose Kit	7-74
7-36	1254 Chassis Hose Kit	7-78

## Numerical List of Parts Breakdowns – Cont.

<u>Figure No.</u>	<u>Title</u>	<u>Page No.</u>
8-1	Electrical Assembly	8-2
8-2	Electrical Center Assembly	8-7
8-3	Terminal Strip Assembly	8-9
8-4	Terminal Strip Assembly	8-11
8-5	Terminal Strip Assembly	8-13
8-6	Engine Relay Assembly	8-15
8-7	Battery Disconnect Switch Assembly	8-17
8-8	Fuse Block Assembly	8-19
8-9	Solenoid Assembly	8-21
9-1	1245 Boom Assembly	9-2
9-2	1254 Boom Assembly	9-7
9-3	1245 Outer Boom Assembly	9-12
9-4	1254 Outer Boom Assembly	9-16
9-5	1245 Mid Boom Assembly	9-20
9-6	1254 Mid Boom Assembly	9-26
9-7	1245 Inner Boom Assembly	9-32
9-8	1254 Inner Boom Assembly	9-35
9-9	1245 Inner Boom Subassembly	9-38
9-10	1254 Inner Boom Subassembly	9-41
9-11	1245 Inner Boom Subassembly	9-44
9-12	1254 Inner Boom Subassembly	9-46
9-13	Angle Indicator Assembly	9-48
9-14	Adapter Assembly	9-50
9-15	Slide Block Assembly	9-52
9-16	Outer Boom Roller Assembly	9-54
9-17	Mid Boom Roller Assembly	9-56
9-18	Roller Assembly	9-58
9-19	Roller Assembly	9-60
9-20	Roller Assembly	9-62
9-21	Chain Sheave Assembly	9-64
9-22	Chain Sheave Assembly	9-66
9-23	Belleville Spring Stack	9-68
9-24	Tube Clamp Assembly No. 2	9-70
9-25	Hose Clamp Assembly	9-72

## Numerical List of Parts Breakdowns – Cont.

<u>Figure No.</u>	<u>Title</u>	<u>Page No.</u>
10-1	1245 Cab Assembly .....	10-2
10-2	1254 Cab Assembly .....	10-7
10-3	Enclosed Cab Assembly.....	10-12
10-4	Front Control Console Assembly.....	10-16
10-5	Front Control Panel Assembly.....	10-19
10-6	Control Enclosure Subassembly .....	10-21
10-7	1245 Side Control Console Assembly.....	10-24
10-8	1254 Side Control Console Assembly.....	10-26
10-9	Side Console Cover Assembly.....	10-30
10-10	Side Console Subassembly.....	10-32
10-11	Handle Boot Assembly .....	10-34
10-12	Accelerator Pedal Assembly.....	10-36
10-13	Front Cover Assembly .....	10-38
10-14	Engine Cover Assembly .....	10-41
10-15	Radiator Cover Assembly.....	10-44
10-16	Battery Cover Assembly .....	10-46
10-17	Rear Light Assembly .....	10-48
10-18	Radiator Shroud Assembly.....	10-50
10-19	Filler Plate Assembly .....	10-52
10-20	Console Roller Assembly .....	10-54
11-1	Standard Carriage Assembly.....	11-2
11-2	Optional Carriage Assembly.....	11-4
11-3	Rotate Carriage Assembly.....	11-6
11-4	Carriage Post Assembly .....	11-8
11-5	Carriage Pin Assembly.....	11-10

THIS PAGE INTENTIONALLY LEFT BLANK

# Section 1

## General Information

**Table 1-1. Abbreviations & Acronyms**

<u>Term</u>	<u>Meaning</u>
A	Amperes
ASTM	American Society for Testing and Materials
AWG	American Wire Gauge
BHC	Button head cap
BKDN	Breakdown
DIA	Diameter
DPDT	Double-pole, double-throw
FSHC	Flat socket head cap
FTG	Fittings
HHC	Hex head cap
ID	Inside diameter
LG	Long
MM	Millimeter
NHA	Next higher assembly
NPT	National pipe thread
OD	Outside diameter
OHM	Oval head machine
PHM	Pan head machine
PWH	Pan washer head
QD	Quick-Disconnect
REF	Reference
REG	Regular
SAE	Society of Automotive Engineers
SBHC	Socket button head cap
SHC	Socket head cap
SHS	Socket head shoulder



<b><u>Term</u></b>	<b><u>Meaning</u></b>
SPDT	Single-throw, double-pole
SPST	Single-pole, single-throw
STR	Straight
THD	Thread
UNC	Unified National Coarse
UNF	Unified National Fine
V	Volts

## **Section 2**

### **Chassis**

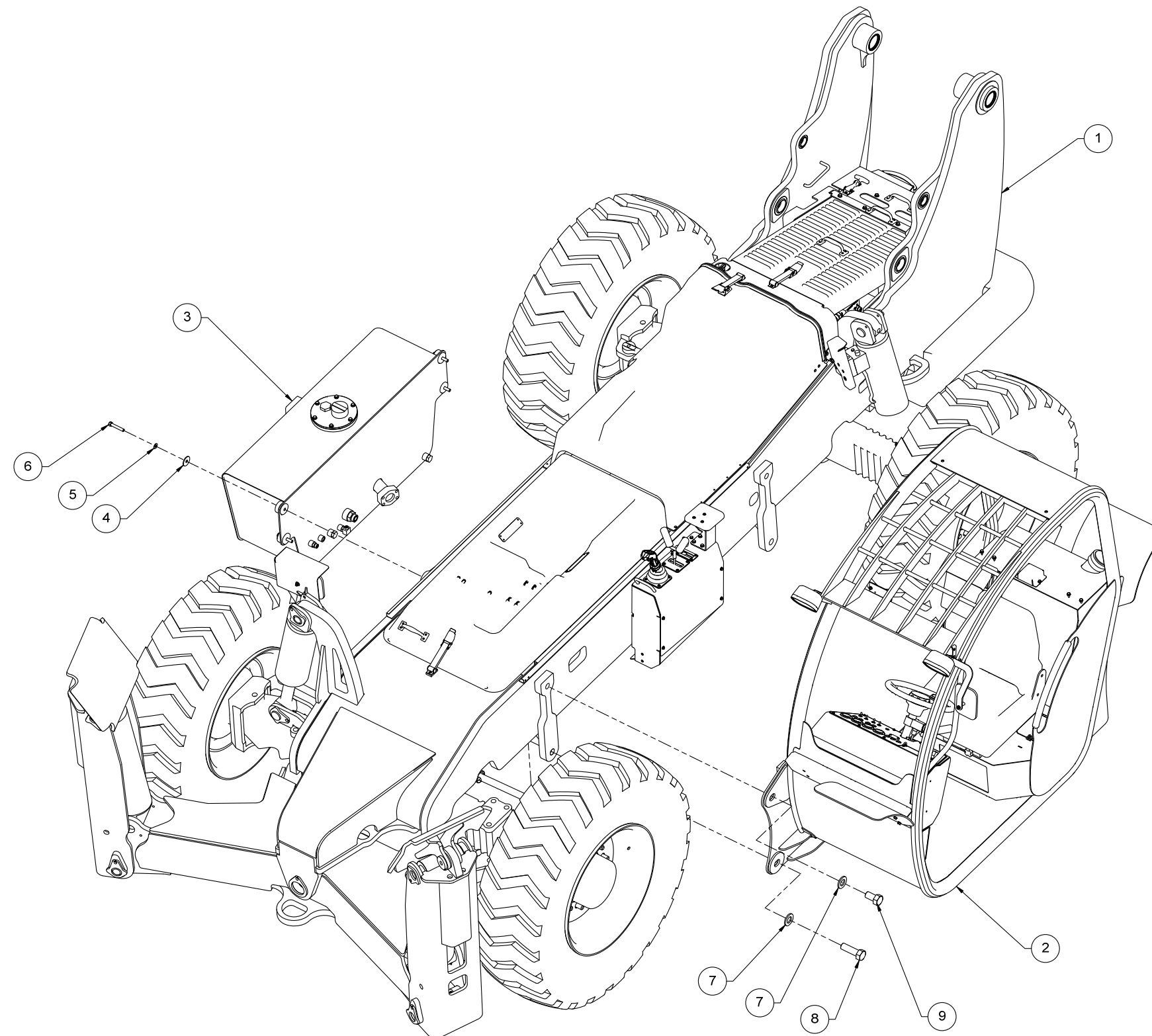

Figure 2-1. 1245 Basic Assembly

**Table 2-1. 1245 Basic Assembly**

<b>Figure &amp; Item No.</b>	<b>Part No.</b>	<b>Description</b>	<b>Quantity</b>	<b>Use On</b>
–	25701-001	1245 Basic assembly	–	–
2-1-1	25702-000	1245 Chassis assembly covers and console	1	–
2-1-2	27408-000	Cab assembly	1	–
2-1-3	26641-001	Hydraulic tank assembly	1	–
2-1-4	25383-000	Pin retainer plate	4	–
2-1-5	11001-008	Washer 1/2" SAE flat	4	–
2-1-6	10004-024	Screw 1/2-13UNC HHC x 3"	4	–
2-1-7	11002-020	Extra thick grade 8 SAE washer	6	–
2-1-8	10031-032	Screw 1-1/4-12UNF HHC x 4"	2	–
2-1-9	10031-018	Screw 1-1/4-12UNF HHC x 2-1/4"	2	–
2-1-10	10901-020	Nut 1-1/4-12UNF reg hex	2	–

Refer to Section 1 for the definition of acronyms and abbreviations used in the Description Column.