

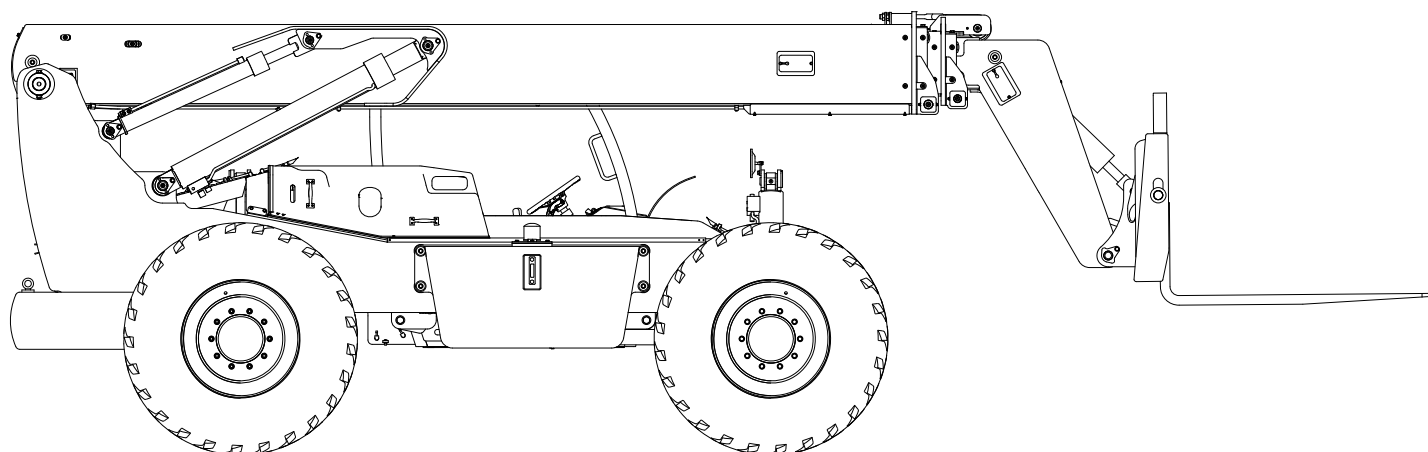

## **Illustrated Parts Breakdown Manual**

### **Forward Reach Forklift**

### **Model XR1045**



**Xtreme Manufacturing  
1415 West Bonanza Road  
Las Vegas, NV 89106  
(702) 636-2969  
[www.xtrememanufacturing.com](http://www.xtrememanufacturing.com)**

Copyright © 2006 By Xtreme Manufacturing

## List of Effective Pages

This manual consists of 385 pages as listed below:

- Outside title page
- Inside title page
- Pages A through D
- Pages i through viii
- Pages 1-1 through 1-2
- Pages 2-1 through 2-22
- Pages 3-1 through 3-22
- Pages 4-1 through 4-16
- Pages 5-1 through 5-10
- Pages 6-1 through 6-12
- Pages 7-1 through 7-54
- Pages 8-1 through 8-26
- Pages 9-1 through 9-48
- Pages 10-1 through 10-50
- Pages 11-1 through 11-12
- Index 1 through Index 90
- Warranty 1 through Warranty 2
- Inside back cover
- Outside back cover

## Service Bulletins

The following service bulletins have been incorporated in this manual:

Title	Bulletin No.	Comments

## Design Change Notices

The following design change notices have been incorporated in this manual:

Title	Design Change Notice No.	Comments

THIS PAGE INTENTIONALLY LEFT BLANK

## Table of Contents

<u>Chap./Par.</u>	<u>Title</u>	<u>Page</u>
	List of Effective Pages .....	A
	Service Bulletins .....	B
	Design Change Notices .....	C
	Alphabetical List of Parts Breakdowns .....	ii
	Numerical List of Parts Breakdowns .....	v
	Section 1 – General Information .....	1-1
	Section 2 – Chassis .....	2-1
	Section 3 – Labels and Load Charts .....	3-1
	Section 4 – Engine .....	4-1
	Section 5 – Transmission, Axles, and Driveshafts .....	5-1
	Section 6 – Steering, Brakes, Wheels, and Tires .....	6-1
	Section 7 – Hydraulic System .....	7-1
	Section 8 – Electrical System .....	8-1
	Section 9 – Boom .....	9-1
	Section 10 – Cab and Consoles .....	10-1
	Section 11 – Boom Attachments .....	11-1
	Numerical and Alphabetical Indexes .....	Index 1

## Alphabetical List of Parts Breakdowns

<u>Title</u>	<u>Figure No.</u>	<u>Page No.</u>
Accelerator Pedal Assembly .....	10-9.....	10-30
Accumulator Assembly.....	6-3.....	6-6
Accumulator Charge Valve Assembly.....	6-4.....	6-8
Adapter Assembly.....	9-8.....	9-27
Air Cleaner Assembly.....	4-4.....	4-13
Angle Indicator Assembly.....	9-7.....	9-25
Axle Cylinder Subassembly .....	7-25.....	7-52
Basic Assembly .....	2-1.....	2-2
Battery Cover Assembly.....	10-13.....	10-40
Battery Disconnect Switch Assembly.....	8-7.....	8-16
Belleville Spring Stack.....	9-16.....	9-43
Boom Assembly .....	9-1.....	9-2
Boom Manifold Assembly.....	7-6.....	7-14
Brake Pressure Switch Assembly .....	6-5.....	6-10
Brake Valve Assembly .....	6-2.....	6-4
Cab Assembly .....	10-1.....	10-2
Carriage Pin Assembly.....	11-5.....	11-10
Carriage Post Assembly.....	11-4.....	11-8
Carriage Tilt Cylinder Assembly.....	7-18.....	7-38
Chain Sheave Assembly .....	9-14.....	9-39
Chain Sheave Assembly .....	9-15.....	9-41
Chassis Assembly – Axles .....	2-4.....	2-13
Chassis Assembly – Covers & Console.....	2-5.....	2-18
Chassis Assembly – Engine.....	2-3.....	2-6
Console Roller Assembly .....	10-17.....	10-48
Control Enclosure Subassembly.....	10-5.....	10-16
Cylinder Collar Assembly .....	7-14.....	7-30
Dipstick Tube Assembly.....	5-2.....	5-5
Distribution Manifold Assembly.....	7-4.....	7-8
Electrical Assembly .....	8-1.....	8-2
Electrical Center Assembly .....	8-2.....	8-6
Enclosed Cab Assembly .....	10-2.....	10-9
Engine Cover Assembly.....	10-11.....	10-35

## Alphabetical List of Parts Breakdowns – Cont.

<u>Title</u>	<u>Figure No.</u>	<u>Page No.</u>
Engine Relay Assembly .....	8-6.....	8-14
Engine Transmission Assembly .....	4-1.....	4-2
Extend Cylinder Assembly .....	7-13.....	7-28
Extend Cylinder Housing Assembly .....	7-15.....	7-32
Extend Cylinder Pin Assembly .....	7-17.....	7-36
Extend Cylinder Support Assembly .....	7-16.....	7-34
Filler Plate Assembly.....	10-16.....	10-46
Final Assembly .....	2-2.....	2-4
Front Axle Assembly .....	5-3.....	5-7
Front Axle Cylinder Assembly .....	7-22.....	7-46
Front Control Console Assembly .....	10-3.....	10-13
Front Control Panel Assembly .....	10-4.....	10-16
Front Cover Assembly.....	10-10.....	10-32
Front Handle Assembly.....	7-8.....	7-18
Fuel Tank Assembly.....	4-5.....	4-15
Fuse Block Assembly.....	8-8.....	8-18
High-Pressure Filter/Steering Valve Assembly .....	7-2.....	7-4
Hose Clamp Assembly.....	9-18.....	9-47
Hydraulic Tank Assembly.....	7-1.....	7-2
Inner Boom Assembly .....	9-4.....	9-17
Inner Boom Subassembly .....	9-5.....	9-20
Inner Boom Subassembly .....	9-6.....	9-23
Isolation Manifold Assembly.....	7-5.....	7-11
Labels and Load Charts .....	3-1.....	3-2
Lift Cylinder Assembly.....	7-12.....	7-26
Master Cylinder Assembly .....	7-11.....	7-24
Mid Boom Assembly .....	9-3.....	9-11
Mid Boom Roller Assembly .....	9-11.....	9-33
Operator Control Valve Assembly.....	7-7.....	7-16
Optional Carriage Assembly .....	11-2.....	11-4
Outer Boom Assembly .....	9-2.....	9-7
Outer Boom Roller Assembly.....	9-10.....	9-31
Overflow Tank Assembly .....	4-3.....	4-11
Radiator Assembly .....	4-2.....	4-8



## Alphabetical List of Parts Breakdowns – Cont.

<u>Title</u>	<u>Figure No.</u>	<u>Page No.</u>
Radiator Cover Assembly .....	10-12.....	10-38
Radiator Shroud Assembly .....	10-15.....	10-44
Rear Axle Assembly .....	5-4.....	5-9
Rear Axle Cylinder Assembly.....	7-23.....	7-48
Rear Axle Lock Manifold Assembly .....	7-24.....	7-50
Rear Handle Assembly .....	7-10.....	7-22
Rear Light Assembly .....	10-14.....	10-42
Rear Steering Valve Assembly .....	7-3.....	7-6
Roller Assembly .....	9-12.....	9-35
Roller Assembly .....	9-13.....	9-37
Rotate Carriage Assembly .....	11-3.....	11-6
Rotate Cylinder Assembly.....	7-20.....	7-42
Rotate Cylinder Subassembly.....	7-21.....	7-44
Side Console Cover Assembly .....	10-7.....	10-26
Side Console Subassembly .....	10-8.....	10-28
Side Control Console Assembly .....	10-6.....	10-22
Slide Block Assembly.....	9-9.....	9-29
Solenoid Assembly.....	8-9.....	8-20
Standard Carriage Assembly .....	11-1.....	11-2
Steering Column Assembly.....	6-1.....	6-2
Sway Valve Handle Assembly .....	7-9.....	7-20
Terminal Strip Assembly .....	8-3.....	8-8
Terminal Strip Assembly .....	8-4.....	8-10
Terminal Strip Assembly .....	8-5.....	8-12
Tilt Cylinder Subassembly.....	7-19.....	7-40
Transmission and Pump Assembly.....	5-1.....	5-2
Tube Clamp Assembly No. 2 .....	9-17.....	9-45

## Numerical List of Parts Breakdowns

<u>Figure No.</u>	<u>Title</u>	<u>Page No.</u>
2-1	Basic Assembly	2-2
2-2	Final Assembly	2-4
2-3	Chassis Assembly – Engine	2-6
2-4	Chassis Assembly – Axles	2-13
2-5	Chassis Assembly – Covers & Console	2-18
3-1	Labels and Load Charts	3-2
4-1	Engine Transmission Assembly	4-2
4-2	Radiator Assembly	4-8
4-3	Overflow Tank Assembly	4-11
4-4	Air Cleaner Assembly	4-13
4-5	Fuel Tank Assembly	4-15
5-1	Transmission and Pump Assembly	5-2
5-2	Dipstick Tube Assembly	5-5
5-3	Front Axle Assembly	5-7
5-4	Rear Axle Assembly	5-9
6-1	Steering Column Assembly	6-2
6-2	Brake Valve Assembly	6-4
6-3	Accumulator Assembly	6-6
6-4	Accumulator Charge Valve Assembly	6-8
6-5	Brake Pressure Switch Assembly	6-10
7-1	Hydraulic Tank Assembly	7-2
7-2	High-Pressure Filter/Steering Valve Assembly	7-4
7-3	Rear Steering Valve Assembly	7-6
7-4	Distribution Manifold Assembly	7-8
7-5	Isolation Manifold Assembly	7-11
7-6	Boom Manifold Assembly	7-14
7-7	Operator Control Valve Assembly	7-16
7-8	Front Handle Assembly	7-18
7-9	Sway Valve Handle Assembly	7-20
7-10	Rear Handle Assembly	7-22
7-11	Master Cylinder Assembly	7-24
7-12	Lift Cylinder Assembly	7-26

## Numerical List of Parts Breakdowns – Cont.

<u>Figure No.</u>	<u>Title</u>	<u>Page No.</u>
7-13	Extend Cylinder Assembly.....	7-28
7-14	Cylinder Collar Assembly .....	7-30
7-15	Extend Cylinder Housing Assembly .....	7-32
7-16	Extend Cylinder Support Assembly .....	7-34
7-17	Extend Cylinder Pin Assembly .....	7-36
7-18	Carriage Tilt Cylinder Assembly .....	7-38
7-19	Tilt Cylinder Subassembly .....	7-40
7-20	Rotate Cylinder Assembly .....	7-42
7-21	Rotate Cylinder Subassembly .....	7-44
7-22	Front Axle Cylinder Assembly .....	7-46
7-23	Rear Axle Cylinder Assembly .....	7-48
7-24	Rear Axle Lock Manifold Assembly .....	7-50
7-25	Axle Cylinder Subassembly.....	7-52
8-1	Electrical Assembly .....	8-2
8-2	Electrical Center Assembly.....	8-6
8-3	Terminal Strip Assembly.....	8-8
8-4	Terminal Strip Assembly.....	8-10
8-5	Terminal Strip Assembly.....	8-12
8-6	Engine Relay Assembly.....	8-14
8-7	Battery Disconnect Switch Assembly .....	8-16
8-8	Fuse Block Assembly .....	8-18
8-9	Solenoid Assembly .....	8-20
9-1	Boom Assembly.....	9-2
9-2	Outer Boom Assembly.....	9-7
9-3	Mid Boom Assembly.....	9-11
9-4	Inner Boom Assembly .....	9-17
9-5	Inner Boom Subassembly .....	9-20
9-6	Inner Boom Subassembly .....	9-23
9-7	Angle Indicator Assembly .....	9-25
9-8	Adapter Assembly .....	9-27
9-9	Slide Block Assembly .....	9-29
9-10	Outer Boom Roller Assembly .....	9-31
9-11	Mid Boom Roller Assembly .....	9-33
9-12	Roller Assembly.....	9-35
9-13	Roller Assembly.....	9-37

## Numerical List of Parts Breakdowns – Cont.

<u>Figure No.</u>	<u>Title</u>	<u>Page No.</u>
9-14	Chain Sheave Assembly	9-39
9-15	Chain Sheave Assembly	9-41
9-16	Belleville Spring Stack	9-43
9-17	Tube Clamp Assembly No. 2	9-45
9-18	Hose Clamp Assembly	9-47
10-1	Cab Assembly	10-2
10-2	Enclosed Cab Assembly	10-9
10-3	Front Control Console Assembly	10-13
10-4	Front Control Panel Assembly	10-16
10-5	Control Enclosure Subassembly	10-18
10-6	Side Control Console Assembly	10-22
10-7	Side Console Cover Assembly	10-26
10-8	Side Console Subassembly	10-28
10-9	Accelerator Pedal Assembly	10-30
10-10	Front Cover Assembly	10-32
10-11	Engine Cover Assembly	10-35
10-12	Radiator Cover Assembly	10-38
10-13	Battery Cover Assembly	10-40
10-14	Rear Light Assembly	10-42
10-15	Radiator Shroud Assembly	10-44
10-16	Filler Plate Assembly	10-46
10-17	Console Roller Assembly	10-48
11-1	Standard Carriage Assembly	11-2
11-2	Optional Carriage Assembly	11-4
11-3	Rotate Carriage Assembly	11-6
11-4	Carriage Post Assembly	11-8
11-5	Carriage Pin Assembly	11-10

THIS PAGE INTENTIONALLY LEFT BLANK

# Section 1

## General Information

**Table 1-1. Abbreviations & Acronyms**

<u>Term</u>	<u>Meaning</u>
A	Amperes
ASTM	American Society for Testing and Materials
AWG	American Wire Gauge
BHC	Button head cap
BKDN	Breakdown
DIA	Diameter
DPDT	Double-pole, double-throw
FSHC	Flat socket head cap
FTG	Fittings
HHC	Hex head cap
ID	Inside diameter
LG	Long
MM	Millimeter
NHA	Next higher assembly
NPT	National pipe thread
OD	Outside diameter
OHM	Oval head machine
PHM	Pan head machine
PWH	Pan washer head
QD	Quick-Disconnect
REF	Reference
REG	Regular
SAE	Society of Automotive Engineers
SBHC	Socket button head cap
SHC	Socket head cap
SHS	Socket head shoulder

<b><u>Term</u></b>	<b><u>Meaning</u></b>
SPDT	Single-throw, double-pole
SPST	Single-pole, single-throw
STR	Straight
THD	Thread
UNC	Unified National Coarse
UNF	Unified National Fine
V	Volts

## **Section 2**

### **Chassis**



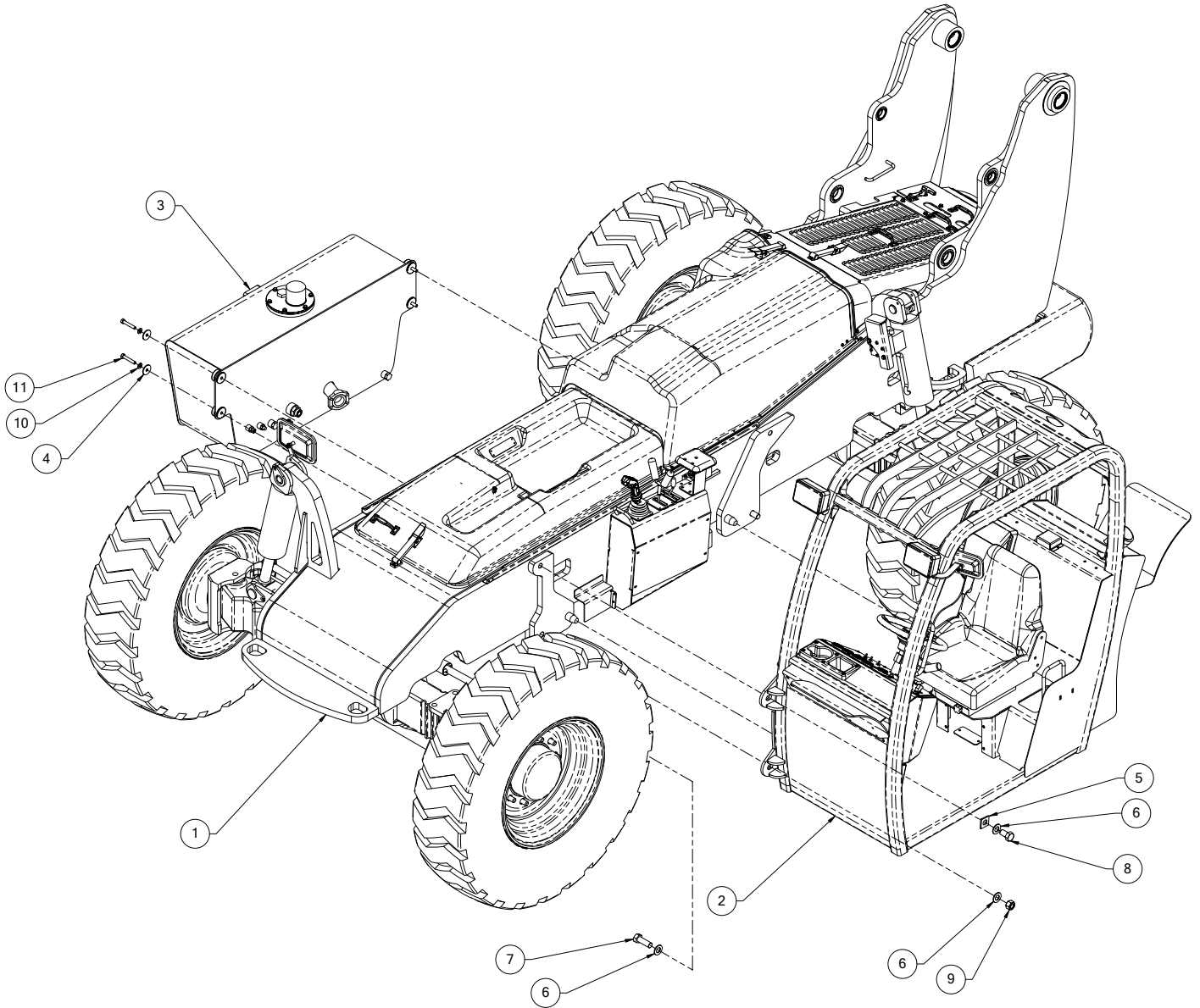

Figure 2-1. Basic Assembly

Table 2-1. Basic Assembly

Figure & Item No.	Part No.	Description	Quantity	Use On
–	26631-000	Basic assembly	–	–
2-1-1	26632-000	Chassis assembly	1	–
2-1-2	26741-000	Cab assembly	1	–
2-1-3	26641-001	Hydraulic tank assembly	1	–
2-1-4	25383-000	Pin retainer plate	4	–
2-1-5	11011-016	Washer 1" ID square	2	–
2-1-6	11001-016	Washer 1" dia SAE flat	6	–
2-1-7	10029-024	Screw 1-14UNF HHC x 3"	2	–
2-1-8	10029-014	Screw 1-14UNF HHC x 1 3/4"	2	–
2-1-9	10901-016	Nut 1-14UNF reg hex	2	–
2-1-10	11001-008	Washer 1/2" SAE flat	4	–
2-1-11	10004-024	Screw 1/2-13UNC HHC x 3"	4	–

Refer to Section 1 for the definition of acronyms and abbreviations used in the Description Column.

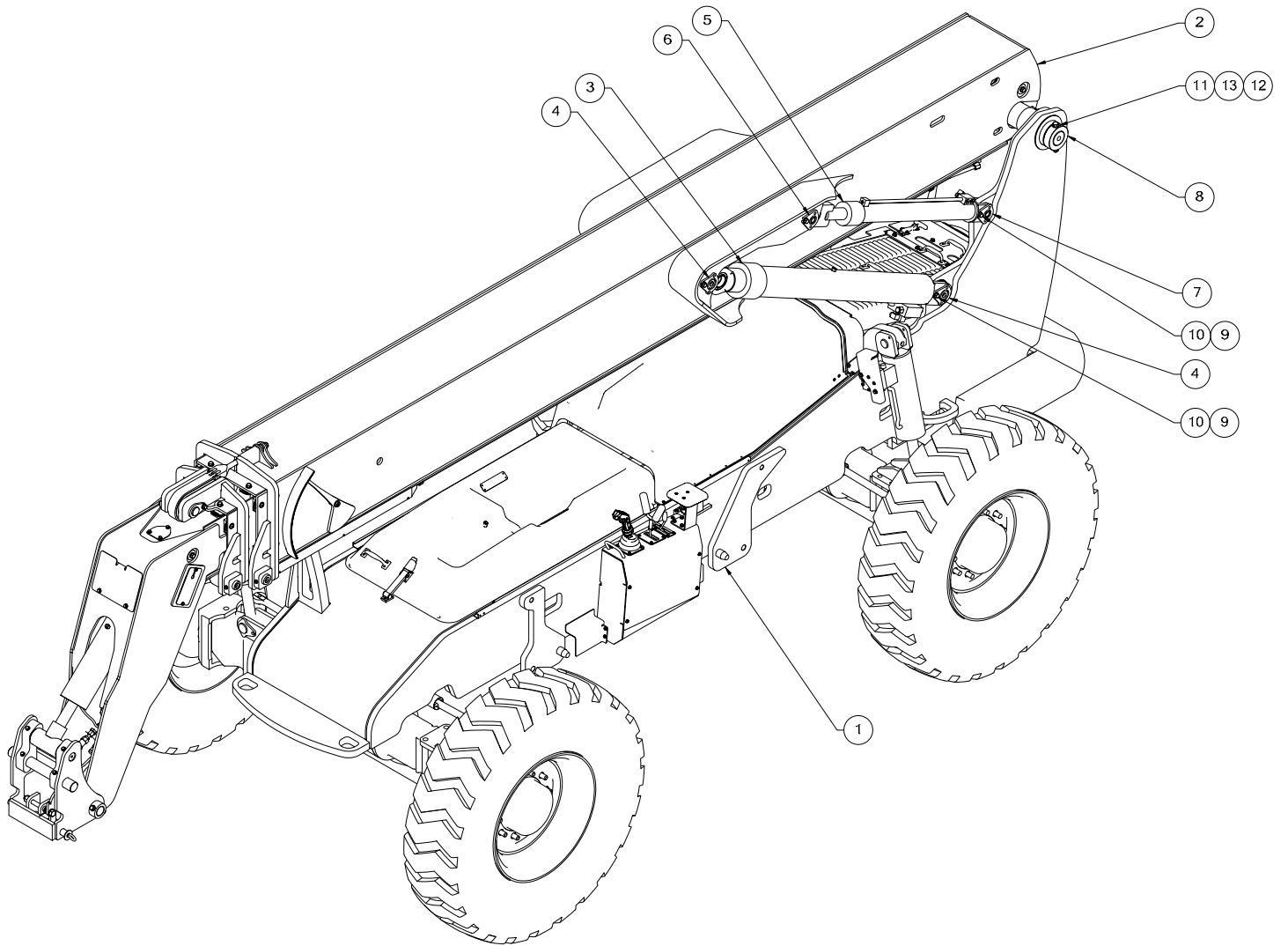

Figure 2-2. Final Assembly

**Table 2-2. Final Assembly**

<b>Figure &amp; Item No.</b>	<b>Part No.</b>	<b>Description</b>	<b>Quantity</b>	<b>Use On</b>
–	25876-000	Final assembly	–	–
2-2-1	26632-000	Chassis assembly – covers & console	1	–
2-2-2	25874-000	Boom assembly	1	–
2-2-3	26670-000	Lift cylinder assembly	2	–
2-2-4	27077-000	Lift cylinder pin assembly	4	–
2-2-5	26322-000	Master cylinder assembly	2	–
2-2-6	27062-000	Master cylinder pin assembly	2	–
2-2-7	27064-000	Master cylinder pin assembly	2	–
2-2-8	25625-000	Shaft collar	2	–
2-2-9	11002-008	1/2" extra heavy grade 8 SAE washer	8	–
2-2-10	10004-010	Screw 1/2-13UNC HHC x 1-1/4"	8	–
2-2-11	11001-010	Washer 5/8SAE flat	4	–
2-2-12	10900-010	Nut 5/8-11UNC reg hex	2	–
2-2-13	10006-048	Screw 5/8-11UNC HHC x 6"	2	–

Refer to Section 1 for the definition of acronyms and abbreviations used in the Description Column.