

en

Operating Manual

Wheel Loader
L507 - 777 from 12800



LIEBHERR

en

Operating Manual

Wheel Loader
L507 - 777 from 12800

Document identification

Order number: 10044705
Version: 02 / 2006
Document version: 02
Valid for: L507 - 777 from 12800
Author: LBH – Technical Documentation Department

Product identification

Type: L507
Type no.: 777
Serial number: from 12800
Conformity:



Address

Address: LIEBHERR-WERK BISCHOFSHOFEN GMBH
Dr. Hans Liebherr – Straße 4
A – 5500 BISCHOFSHOFEN

Manufacturer

Address: LIEBHERR-WERK BISCHOFSHOFEN GMBH

Machine data:

Please enter the following details on receipt of your vehicle: *You will find these details on the vehicle type plate. They will be useful when ordering spare parts.

*** Serial no.**

VATZ ZZB

*** Year of manufacture**

.

Initial start-up date

. . / . . / . .

This operating manual has been written for the **driver** and for the **maintenance personnel** of the machine.

It describes:

- Chapter 1 - Product description
- Chapter 2 - Safety regulations
- Chapter 3 - Operation and handling
- Chapter 4 - Malfunctions
- Chapter 5 - Maintenance

This operating manual must be carefully read before initial operation and should be read and used later at regular intervals by anyone responsible for working on the machine.

Working with or on the machine includes:

- **Operation**, including equipping, troubleshooting during operation, removing production debris, maintenance, removing operating and auxiliary materials.
- **Servicing**, including maintenance, inspection and repairs.
- **Transport** or loading the machine.

This manual helps the driver to become acquainted with the machine and prevents malfunctions due to improper operation.

Observation of the operating manual by maintenance staff:

- Increases reliability during operation
- Extends the service life of your machine
- Reduces repair costs and downtime

This manual must be kept with the machine. Place a copy within easy reach in the glove compartment in the driver's cab.

In addition to the operating manual follow the instructions based on existing national accident prevention and environmental protection regulations.

In addition to the operating manual and applicable national and local legal accident prevention rules, observe the recognised technical regulations for safe and proper operation.

This operating manual contains all the information you need to operate and service your machine.

If you should, however, require more detailed explanations or information, our technical information and customer services departments will be happy to provide assistance.

You will understand that we cannot accept warranty claims for damage due to improper use, insufficient maintenance, use of non-approved consumables or failure to follow the safety instructions.

LIEBHERR will cancel without prior notice all obligations such as warranty agreements and service contracts entered into by **LIEBHERR** and/or its agents if spare parts other than genuine **LIEBHERR** parts or those purchased from **LIEBHERR** are used for maintenance and repairs.

In extreme conditions, maintenance may be required more often than stated in the inspection schedule.

Modifications, conditions, copyright:

- We reserve the right to alter the technical details of the machine regardless of the specifications and illustrations in these documents.
- The warranty and liability terms contained in LIEBHERR's general conditions of trade are not affected by the information in the manual.
- The information and illustrations in this manual may not be reproduced, distributed or used for commercial purposes. All rights under copyright laws are expressly reserved.

Abbreviations used:

CPU = central processing unit
Hydr. = hydraulic
LCD = liquid crystal display
LED = light emitting diode
LECU = Liebherr Electronic Control Unit
LFD = Liebherr ride control
LH = Liebherr
LKW = truck
MC = microcontroller
MV = solenoid valve
NLP = emergency steering pump
P-kinematics = kinematic version of the lift arms
SKW = heavy lorry
SW = quick-change device
UEC = universal earth mover controller
Z-kinematics = kinematic version of the lift arms

Symbols and pictograms:

Direction of operation or movement



bsym0059



bsym0066



bsym0065



bsym0029



bsym0049



bsym0061



bsym0060



bpik0006



bsym0063

Reply form

We need your help to continually improve our documentation. Please copy this page and fax it or e-mail it to us with your comments, ideas and suggestions for improvement.

To: Liebherr Werk Bischofshofen GmbH
Dr. Hans Liebherr Strasse 4
5500 Bischofshofen / Austria

Fax: 0043 6462 888 287

E-mail: roland.weber@liebherr.com

Ideas, comments (please state the page number):

Overall, how would you judge this document?

Excellent	
Very good	
Good	
Satisfactory	
Poor	

Your data: Machine / serial number: _____

Company: _____

Name: _____

Address: _____

Telephone number: _____

Dealer: _____

Thank you for your help.

LBH/02/003801/0003/2.06/en

Contents

1	Product description	1 - 1
1.1	Technical data	1 - 2
1.1.1	Complete machine with bucket	1 - 2
1.1.2	Engine	1 - 3
1.1.3	Electrical system	1 - 4
1.1.4	Travel drive	1 - 4
1.1.5	Axles	1 - 4
1.1.6	Braking	1 - 5
1.1.7	Steering	1 - 5
1.1.8	Working hydraulics	1 - 5
1.1.9	Working attachment	1 - 6
1.1.10	Driver's cab	1 - 7
1.1.11	Heating and ventilation	1 - 7
1.1.12	Sound emission	1 - 7
1.1.13	Towing device	1 - 8
1.1.14	Tyres	1 - 8
1.1.15	Air-conditioning system	1 - 10
1.1.16	Snow chains or guard chains	1 - 11
1.1.17	Soot particle filter	1 - 11
1.1.18	Light material bucket with undercut blade	1 - 13
1.1.19	4 in 1 bucket	1 - 15
1.1.20	Forklift	1 - 17
2	Safety regulations	2 - 1
2.1	Introduction	2 - 1
2.2	General safety regulations	2 - 1
2.3	Proper use	2 - 3
2.4	Decals on the machine	2 - 3
2.4.1	Location of decals	2 - 4

2.4.2	Safety decals	2 - 4
2.4.3	Information decals	2 - 6
2.4.4	Type plates	2 - 10
2.5	Instructions on preventing crushing injuries and burns	2 - 10
2.6	Instructions on preventing fires and explosions	2 - 11
2.7	Safety instructions for start-up	2 - 12
2.8	Safety precautions during start-up	2 - 12
2.9	Instructions for safe working	2 - 13
2.10	Safety instructions for driving on slopes	2 - 14
2.11	Parking safely	2 - 14
2.12	Transporting the machine safely	2 - 15
2.13	Towing the machine safely	2 - 15
2.14	Measures for ensuring safe maintenance	2 - 16
2.15	Safety instructions for maintenance work on machines with hydro accumulators	2 - 18
2.16	Safety instructions for welding work on the machine	2 - 19
2.17	Instructions for working safely on the working attachment	2 - 19
2.18	Safety instructions for transporting the machine by crane	2 - 20
2.19	Safe maintenance of hydraulic hoses and hose lines	2 - 20
2.20	Attachments and accessories	2 - 21
2.21	Protection against vibrations	2 - 21
3	Operation, Handling	3 - 1
3.1	Layout of control elements	3 - 1
3.2	Operation	3 - 2
3.2.1	Battery main switch	3 - 2
3.2.2	Cab access	3 - 2
3.2.3	Emergency exit	3 - 4
3.2.4	Driver's seat with mechanical suspension	3 - 5
3.2.5	Driver's seat with pneumatic suspension	3 - 10
3.2.6	Seat belt	3 - 15
3.2.7	Steering column and steering wheel	3 - 16

3.2.8	Ignition switch	3 - 17
3.2.9	Steering column switch	3 - 17
3.2.10	Lighting	3 - 19
3.2.11	Interior cab lighting	3 - 20
3.2.12	Display unit	3 - 21
3.2.13	Switches on the side console	3 - 25
3.2.14	LIEBHERR control lever	3 - 30
3.2.15	Control lever for additional working functions and quick-change device	3 - 33
3.2.16	Heating and ventilation	3 - 35
3.2.17	Air-conditioning system	3 - 37
3.2.18	Interior and exterior mirrors	3 - 38
3.2.19	Sun visor	3 - 39
3.2.20	Radio	3 - 39
3.2.21	Windshield wiper and washer system	3 - 40
3.2.22	Windshield washer fluid reservoir	3 - 42
3.3	Handling	3 - 43
3.3.1	Daily start-up	3 - 43
3.3.2	Starting the diesel engine	3 - 46
3.3.3	Driving	3 - 50
3.3.4	Shutting down the machine	3 - 59
3.3.5	Operating the lift arms	3 - 62
3.3.6	Working methods	3 - 70
3.3.7	Soot particle filter	3 - 83
3.3.8	Quick-change device - fitting and removing the working attachment	3 - 85
3.3.9	4 in 1 bucket	3 - 94
3.3.10	Forklift	3 - 95
3.3.11	Transporting the machine	3 - 97
3.4	Emergency operation	3 - 103
3.4.1	Towing the machine	3 - 103
3.4.2	Jump starting	3 - 109
4	Malfunctions	4 - 1
4.1	Service Code Table	4 - 1

4.1.1	Visible and audible warning signals	4 - 2
4.1.2	Troubleshooting	4 - 3
4.2	Eliminating malfunctions	4 - 6
4.2.1	Replacing fuses	4 - 6

5	Maintenance	5 - 1
5.1	Maintenance and inspection schedule	5 - 1
5.2	Lubricant chart, filling quantities	5 - 5
5.2.1	Table of filling quantities	5 - 5
5.2.2	Lubricant chart	5 - 6
5.3	Maintenance tasks	5 - 8
5.3.1	Preparatory tasks for maintenance	5 - 8
5.3.2	Checking the machine for external damage	5 - 12
5.3.3	Making sure the bolted connections are tight	5 - 12
5.3.4	Sealing leaks	5 - 12
5.3.5	Checking the engine oil level	5 - 13
5.3.6	Changing the engine oil	5 - 14
5.3.7	Changing the engine oil filter	5 - 15
5.3.8	Changing the fuel pre-filter	5 - 16
5.3.9	Changing the fuel fine filter	5 - 17
5.3.10	Draining off condensate from the fuel fine filter	5 - 18
5.3.11	Cleaning the air filter service cap and dust extraction valve	5 - 19
5.3.12	Changing the air filter main element when indicated by the vacuum switch	5 - 19
5.3.13	Checking and draining the soot particle filter condensate separator	5 - 21
5.3.14	Checking the coolant level	5 - 21
5.3.15	Checking the coolant antifreeze concentration	5 - 22
5.3.16	Cleaning the cooling system	5 - 24
5.3.17	Checking the oil level in the hydraulic tank	5 - 25
5.3.18	Checking that the steering is working	5 - 25
5.3.19	Lubricating the bearing points on the steering cylinders	5 - 26

5.3.20	Checking the service brake and parking brake	5 - 26
5.3.21	Checking the gap and wear on the service brake linings	5 - 27
5.3.22	Checking the oil level in the equalising reservoir of the brake system	5 - 28
5.3.23	Checking the indicator lamps and lighting	5 - 28
5.3.24	Checking the tightness of the wheels (once after 50, 100 and 250 h)	5 - 29
5.3.25	Greasing the rear axle kingpin bearings	5 - 30
5.3.26	Checking and lubricating the cardan shaft(s)	5 - 31
5.3.27	Checking the tyre pressure	5 - 32
5.3.28	Lubricating the articulation bearing and rear oscillating bearing	5 - 32
5.3.29	Greasing the contact faces of articulation stops	5 - 33
5.3.30	Checking whether metered quantities are adequate at the bearing points (grease collars) of the central lubrication system	5 - 34
5.3.31	Checking the pipes, hoses and lubrication points of the lubrication system	5 - 35
5.3.32	Greasing the cab door hinges	5 - 35
5.3.33	Cleaning or replacing the fresh air and recirculated air filter	5 - 35
5.3.34	Lubricating the lift arms and attachment	5 - 35
5.3.35	Checking the lift arm bearing bushings	5 - 36
5.3.36	Lubricating and testing the quick-change device	5 - 37
5.3.37	Cleaning the machine	5 - 39
5.3.38	Corrosion protection	5 - 40
5.4	Lubricants and fuels	5 - 41
5.4.1	Lubricating oils for diesel engines	5 - 42
5.4.2	Diesel fuels	5 - 43
5.4.3	Coolants for diesel engines	5 - 45
5.4.4	Hydraulic oils	5 - 46
5.4.5	Lubricating oils for the transmission	5 - 48
5.4.6	Brake oil	5 - 48
5.4.7	Grease for general lubrication points	5 - 49

1 Product description

Equipment layout

Standard version

This section contains an overview of the machine and the names of the components shown.

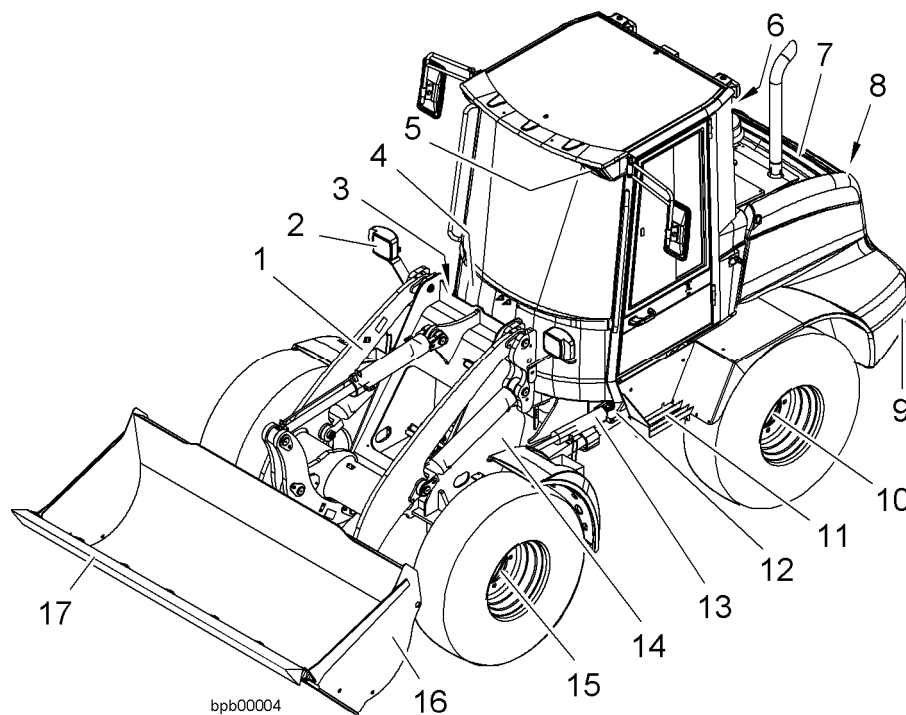

bpb00004

Left view of machine

- | | |
|---------------------------|----------------------|
| 1 Lift arm | 10 Rear axle |
| 2 Lighting | 11 Cab access |
| 3 Articulation lock | 12 Rear section |
| 4 Driver's cab | 13 Steering cylinder |
| 5 Working floodlight | 14 Front section |
| 6 Battery compartment | 15 Front axle |
| 7 Engine compartment hood | 16 Bucket |
| 8 Towing device | 17 Tooth guard |
| 9 Ballast weight | |

1.1 Technical data

1.1.1 Complete machine with bucket



The values stated refer to the machine:

- In its standard version
- With 365/70R18 tyres
- Including all lubricants
- With a full tank
- With ROPS/FOPS cab and driver

Tyre sizes and additional attachments affect the operating weight and tipping load.

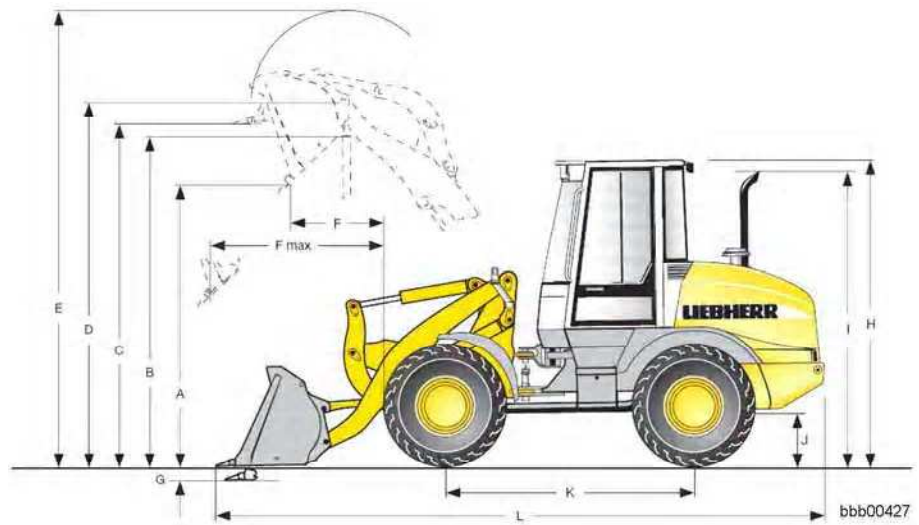

Dimensions

Name	Value	Units
Bucket capacity (ISO 7546) ¹⁾	0.9	m ³
Bucket width	2050	mm
Specific material weight	1.8	t/m ³
A - Dump height at maximum lifting height and 42° tilt-out angle	2550	mm
B - Dump height	2872	mm
C - Maximum bucket base height	3011	mm
D - Maximum bucket pivot point height	3211	mm
E - Maximum bucket top height	4040	mm
F - Reach at maximum lifting height and 42° tilt-out angle	818	mm
F max - Maximum reach at 42° tilt-out angle	1517	mm
G - Digging depth	80	mm

LBH/02/003801/0003/2.06/en

Name	Value	Units
H - Height above the cab	2725	mm
I - Height above exhaust	2600	mm
J - Ground clearance	295	mm
K - Wheel base	2150	mm
L - Overall length	5295	mm
Turning radius over bucket outer edge	3755	mm
Lifting force (SAE)	44	kN
Breakout force (SAE)	48	kN
Tipping load when straight	3836	kg
Articulated tipping load	3501	kg
Operating weight	5240	kg
Tractive force	4593	daN

¹⁾In practice, the bucket capacity can be around 10 % greater than as calculated using the ISO 7546 method. This depends on the type of material.

1.1.2 Engine



bpik0027

Water-cooled Liebherr diesel engine with turbocharger.

The exhaust emissions are below the threshold levels in EU directive 97/68/EC – Stage II.

Name	Value	Units
Diesel engine	D404T-01	
Number of cylinders	4	Pc.
Combustion	Pump-jet	
Rated power according to ISO 9249 at 2800 min ⁻¹	46	kW
Maximum torque at 1680 min ⁻¹	227	Nm
Cylinder capacity	2.44	litres
Idle speed	min.850 ^{±50} max.3040 ⁺⁸⁰	min ⁻¹ min ⁻¹
Longitudinal / traverse inclinability	30	°

1.1.3 Electrical system



bpik0028

Name	Value	Units
Battery voltage	12	V
Battery capacity	100	Ah
Number of batteries	1	Pc.
Operating voltage	12	V
Alternator	12/65	V/ A
Starter	12/2.2	V / kW

Battery fastening

Name	Value	Units
Tightening torque	10	Nm

1.1.4 Travel drive



bpik0029

Continuously variable hydrostatic travel drive

Travel drive controlled by gas pedal and combined inch/brake pedal.

The inch pedal allows you to smoothly adapt the tractive and thrust force to the terrain and conditions.

Forward and reverse travel are selected using the Liebherr control lever

Speed data:

- For forward and reverse travel
- With standard tyres

Name	Value	Units
Travel range 1	0 – 6.0	km/h
Travel range 2	0 – 20.0	km/h

1.1.5 Axles



bpik0030

Front axle

Rigidly mounted planetary axle

Name	Value	Units
Width	1486	mm
Differential lock, automatic action	45	%

Rear axle Oscillating planetary axle
Kingpin steering

Name	Value	Units
Width	1486	mm
Differential lock, automatic action	25	%
Angle of articulation to each side	5	°

1.1.6 Braking



The braking system complies with the roadworthiness certification regulations.

Service brake Hydrostatic travel drive, wear-free, acting on all four wheels, with additional hydraulically operated drum brake.

Parking brake Mechanically operated drum brake.

1.1.7 Steering



“Stereo steering”, central articulation joint with absorbers in combination with kingpin steering on the rear axle.

Name	Value	Units
Angle of articulation to each side	30	°
Angle of articulation of articulated joint to each side	5	°
Maximum operating pressure	180	bar

1.1.8 Working hydraulics



Single lever control with Liebherr control lever, hydraulic pilot control.

Design:

- Gear pump and pressure cut-off

Name	Value	Units
Maximum flow	65	l/min
Maximum operating pressure	230	bar

1.1.9 Working attachment



Lift arm Bearing points – lathed, thick-walled bushings with lubricating grooves

Z kinematics:

- Standard version
- With standard hydraulic quick-change device

Bucket

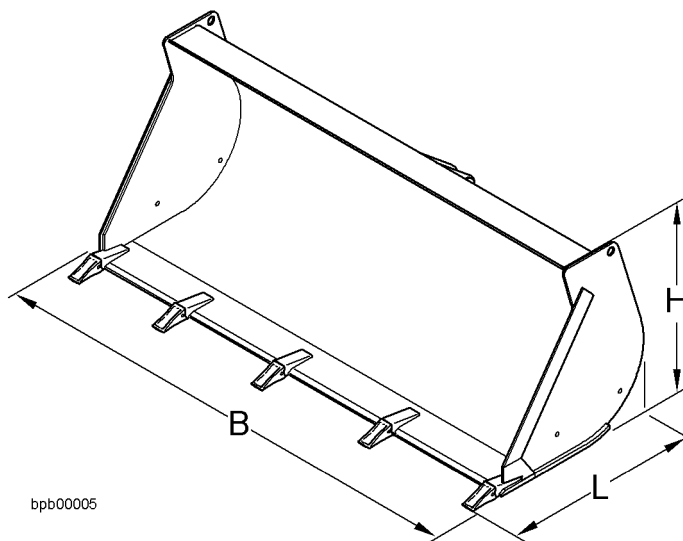

Dimensions

Name	Value	Units
Bucket capacity (ISO 7546)	0.9	m ³
Specific material weight	1.8	t/m ³
B – bucket width	2050	mm
H – height	863	mm
L – length with teeth	910	mm
Weight	321	kg
Teeth – UNI-Z-2000	7	Pc.

LBH/02/003801/0003/2.06/en

1.1.10 Driver's cab



On elastic bearing on rear section, soundproof ROPS/FOPS cab.

Design:

- 2 detachable doors
- The right door is the emergency exit.
- Left door with sliding window
- Tinted windows made of hardened single-glazed safety glass
- ROPS rollover protection in accordance with DIN/ISO 13510/ EN 474-3.
- FOPS stone impact protection in accordance with DIN/ISO 13627/ EN 474-1.

Driver's seat

Alternative versions:

- Driver's seat with mechanical suspension
 - Driver's seat with pneumatic suspension.
- This equipment is optional.

1.1.11 Heating and ventilation

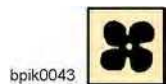

Driver's cab with defroster, fresh air filter, circulated air filter and warm water heating.

Name	Value	Units
Number of blower levels	3	
Heating power	11.3	kW

1.1.12 Sound emission



Sound pressure

Name	Value	Units
ISO 6396 – L _{pA} (in driver's cab)	70	dB (A)

Sound output

You can read the level on the decal on the machine.
See the section on decals on the machine in chapter 2.

LBH/02/003801/0003/2.06/en

1.1.13 Towing device



The towing device is attached to the back of the machine.

Purpose:

- For towing the machine out of a danger area
See the section on emergency operation in chapter 3.
- For lifting the machine by crane
See the section on transporting the machine in chapter 3.

Note



It may not be used for attaching a trailer. The manufacturer/supplier will not be held liable for damage resulting from this.

! See the instructions on proper use and safely towing the machine in chapter 2.

1.1.14 Tyres



The driving performance of the machine depends, among other things, on the tyres.

The same tyre size must be used for all four wheels.

When changing the tyres or if there is increasing wear on the tyres, make sure that the difference in diameter between the tyres on the front and rear axles is no more than 3 %.

Otherwise the axles may be damaged.

The correct tyre pressure is a decisive factor for the proper performance of the machine and for a long tyre lifetime.

You will find the following specifications in the table below:

- Recommended tyre sizes
- Tyre tread
- Tyre pressure

Abbreviations:

- **p – Max.** = maximum permissible air pressure
- **VA** = front axle
- **HA** = rear axle

The air pressure specifications refer to:

- Basic air pressure recommendations - as set when delivered from the factory
- Cold tyres
- Machine ready for operation - basic machine with standard equipment and permissible load



Note

For special uses such as industrial timber handling or other uses where heavier loads may be expected, a higher tyre pressure is recommended, depending on the specific load. However, the tyre pressure may not be greater than the maximum permitted by the tyre manufacturer's specifications.

! Check and adjust the tyre pressure, see the maintenance tasks in chapter 5.

Dunlop tyres Air pressure table for the standard machine

Tyre size	Tyre tread	Air pressure (bar)		
		VA	HA	p – Max.
365/70R18EM ¹⁾	SPT9-TL	3.75	2.50	3.75
405/70R18EM	SPT9-TL	3.00	2.00	3.75
335/80R20EM	SPT9-TL	3.75	2.50	3.75
365/80R20EM	SPT9-TL	3.00	2.00	3.75
405/70R20EM	SPT9-TL	2.75	2.00	3.75

¹⁾Standard tyres

Michelin tyres Air pressure table for the standard machine

Tyre size	Tyre tread	Air pressure (bar)		
		VA	HA	p – Max.
375/75R20EM	XZSL-TL	2.25	1.60	3.80
375/75R20EM	XM27-TL	2.25	1.60	3.80
405/70R20EM	XZSL-TL	2.25	1.60	3.80
405/70R20EM	XM27-TL	2.25	1.60	3.80

Goodyear tyres Air pressure table for the standard machine

Tyre size	Tyre tread	Air pressure (bar)		
		VA	HA	p – Max.
400/70R18EM	IT 520-TL	3.00	2.00	4.00

Bridgestone tyres Air pressure table for the standard machine

Tyre size	Tyre tread	Air pressure (bar)		
		VA	HA	p – Max.
365/80R20EM	VUT-TL	3.30	2.60	3.75
405/70R20EM	VUT-TL	3.20	2.50	3.75

Mitas tyres Air pressure table for the standard machine

Tyre size	Tyre tread	Air pressure (bar)		
		VA	HA	p – Max.
365/80R18	EM-01-TL	4.60	2.80	4.60

LBH/02/003801/0003/2.06/en