

Service Manual Trucks

Group **37**

Electrical Schematic
VN, VHD VERSION2

From Build Date April 2004

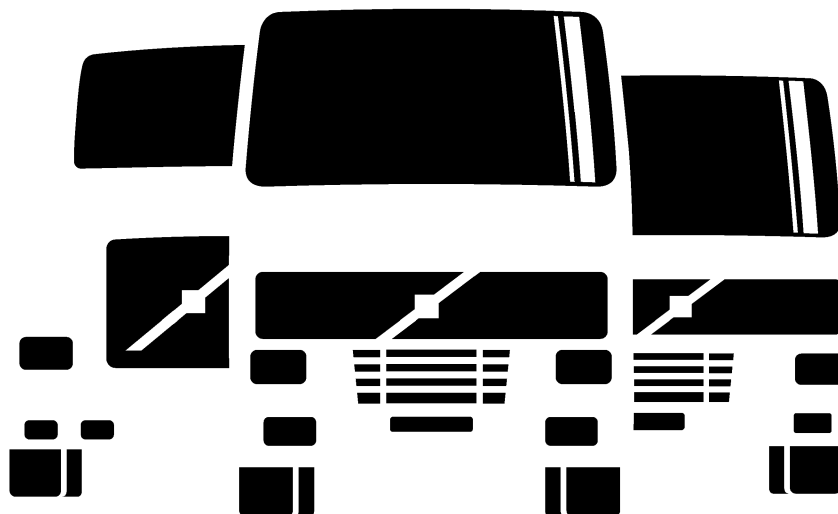

Foreword

The descriptions and service procedures contained in this manual are based on designs and methods studies carried out up to September 2004.

The products are under continuous development. Vehicles and components produced after the above date may therefore have different specifications and repair methods. When this is believed to have a significant bearing on this manual, supplementary service bulletins will be issued to cover the changes.

The new edition of this manual will update the changes.

In service procedures where the title incorporates an operation number, this is a reference to an V.S.T. (Volvo Standard Times).

Service procedures which do not include an operation number in the title are for general information and no reference is made to an V.S.T.

Each section of this manual contains specific safety information and warnings which must be reviewed before performing any procedure. If a printed copy of a procedure is made, be sure to also make a printed copy of the safety information and warnings that relate to that procedure. The following levels of observations, cautions and warnings are used in this Service Documentation:

Note: Indicates a situation, handling or circumstance which should be observed.

Caution: Indicates a potentially hazardous situation which, if not avoided, may result in minor or moderate injury or damage to property.

Warning: Indicates a potentially hazardous situation which, if not avoided, could result in death, serious injury or major damage to property.

Danger: Indicates an imminently hazardous situation which, if not avoided, will result in death or serious injury.

Volvo Trucks North America, Inc.
Greensboro, NC USA

Order number: PV776-20007110

© 2004 Volvo Trucks North America, Inc., Greensboro, NC USA

All rights reserved. No part of this publication may be reproduced, stored in retrieval system, or transmitted in any forms by any means, electronic, mechanical, photocopying, recording or otherwise, without the prior written permission of Volvo Trucks North America, Inc..

USA15171

Contents

VN, VHD	3
Electrical Schematics	3
Illustrations	77
Illustration Index, Wiring Harnesses	77
Reference	149
Reference List: Fuses	149
Reference List: Relays	155
Reference List: Components	156
Reference List: Inline Connectors	176
Reference List: Physical Splice Connectors	186
Glossary	190
Wire Color Codes	191

VN, VHD

Electrical Schematics

For instructions on using the schematics, see service information on “Wiring Diagram User Guide” in Group 37.

Also see:

“Reference List: Fuses” page 149

“Reference List: Components” page 156

“Reference List: Inline Connectors” page 176

“Glossary” page 190

“Wire Color Codes” page 191

Schematic Index

AA	Power supply, starting and charging system (1 of 2)	Fig. 1: AA page 6
AB	Power supply, starting and charging system (2 of 2)	Fig. 2: AB page 7
AC	Grounding (1 of 2)	Fig. 3: AC page 8
AD	Grounding (2 of 2)	Fig. 4: AD page 9
BA	Vehicle ECU (1 of 2)	Fig. 5: BA page 10
BB	Vehicle ECU (2 of 2)	Fig. 6: BB page 11
BC	Instrument cluster, Connectors A and B	Fig. 7: BC page 12
BD	Instrument cluster, Connector C	Fig. 8: BD page 13
BE	Instrumentation, Qualcomm	Fig. 9: BE page 14
BF	Instrumentation, Volvo Link	Fig. 10: BF page 15
BG	Bodybuilder Options, VHD	Fig. 11: BG page 16
BH	Road Relay	Fig. 12: BH page 17
BI	Bodybuilder Module	Fig. 13: BI page 18
BJ	Touch Lock	Fig. 14: BJ page 19
BK	Secondary Instrument Cluster	Fig. 15: BK page 20
CA	Engine Control Common	Fig. 16: CA page 21
CB	Engine Interface, D12	Fig. 17: CB page 22
CC	Engine Control, ISX and ICON	Fig. 18: CC page 23
CE	Fuel filter heater	Fig. 19: CE page 24
CF	Engine brake switches	Fig. 20: CF page 25
CH	Inside/outside air cleaner, VHD	Fig. 21: CH page 26
CI	Engine Control, Cummins ISX without ICON	Fig. 22: CI page 27
CO	Engine Electronics, D12D	Fig. 23: CO page 28
DB	Transmission ECU, Autoshift II	Fig. 24: DB page 29
DC	Transmission ECU, Lightning	Fig. 25: DC page 30

DD	Transmission ECU, Meritor G	Fig. 26: DD page 31
DE	Transmission ECU, Allison, VHD (1 of 2)	Fig. 27: DE page 32
DF	Transmission ECU, Allison, VHD (2 of 2)	Fig. 28: DF page 33
DG	Transmission ECU, Freedomline	Fig. 29: DG page 34
DP	PTO	Fig. 30: DP page 35
EA	ABS ECU	Fig. 31: EA page 36
EB	Suspension ECU 6x2	Fig. 32: EB page 37
FA	Air Dryer / Heated Drain Valve	Fig. 33: FA page 38
FB	Lift Axle, VHD	Fig. 34: FB page 39
FC	Chassis Air Solenoids, VHD	Fig. 35: FC page 40
FD	Chassis Air Solenoids, VN	Fig. 36: FD page 41
FE	Central Tire Inflation system	Fig. 37: FE page 42
GA	LCM Lighting Control Module (1 of 2)	Fig. 38: GA page 43
GB	LCM Lighting Control Module (2 of 2)	Fig. 39: GB page 44
GC	Marker Lights	Fig. 40: GC page 45
GD	Driving / Signal Lights	Fig. 41: GD page 46
GE	Driving / Fog Lights	Fig. 42: GE page 47
GF	Tail Lights and Alarm	Fig. 43: GF page 48
GG	Back of Cab Lights, Daycabs	Fig. 44: GG page 49
GH	Back of Cab Lights, Sleeper cabs	Fig. 45: GH page 50
GI	Snowplow and Beacon Lights	Fig. 46: GI page 51
GP	Windshield Wiper/Washer	Fig. 47: GP page 52
GQ	Horn	Fig. 48: GQ page 53
HA	Climate Control Unit	Fig. 49: HA page 54
HB	Climate Control Unit, Bunk	Fig. 50: HB page 55
HC	Shore Power/Inverter	Fig. 51: HC page 56
HD	Bunk Functions/Refrigerator (VN 430, 630, 670)	Fig. 52: HD page 57
HE	Bunk Functions/Refrigerator/Sink (VN 780)	Fig. 53: HE page 58
HF	L3 Sleeper Functions without LECM	Fig. 54: HF page 59
HG	Sleeper Climate Control without LECM L3	Fig. 55: HG page 60
IA	Interior Courtesy Lights	Fig. 56: IA page 61
IB	Power Seats	Fig. 57: IB page 62
IC	Power Windows/Electric Mirrors	Fig. 58: IC page 63
ID	Power Windows/Mirrors without DCP	Fig. 59: ID page 64
IE	Door Functions/Internal Lights	Fig. 60: IE page 65

IF	Cigar Lighter/Auxiliary Power (Cab Front)	Fig. 61: IF page 66
IG	Smoke Detector	Fig. 62: IG page 67
JA	SRS Airbag	Fig. 63: JA page 68
JB	VORAD	Fig. 64: JB page 69
JC	Steering Wheel Module/Marker Interrupt Switches	Fig. 65: JC page 70
KA	Audio System, 4-speaker	Fig. 66: KA page 71
KB	Audio System, 6-speaker	Fig. 67: KB page 72
KC	Audio System, 6-speaker with subwoofer, TV Prep	Fig. 68: KC page 73
MA	Trailer Cable	Fig. 69: MA page 74
NA	Auxiliary switches	Fig. 70: NA page 75
XA	Diagnostics	Fig. 71: XA page 76

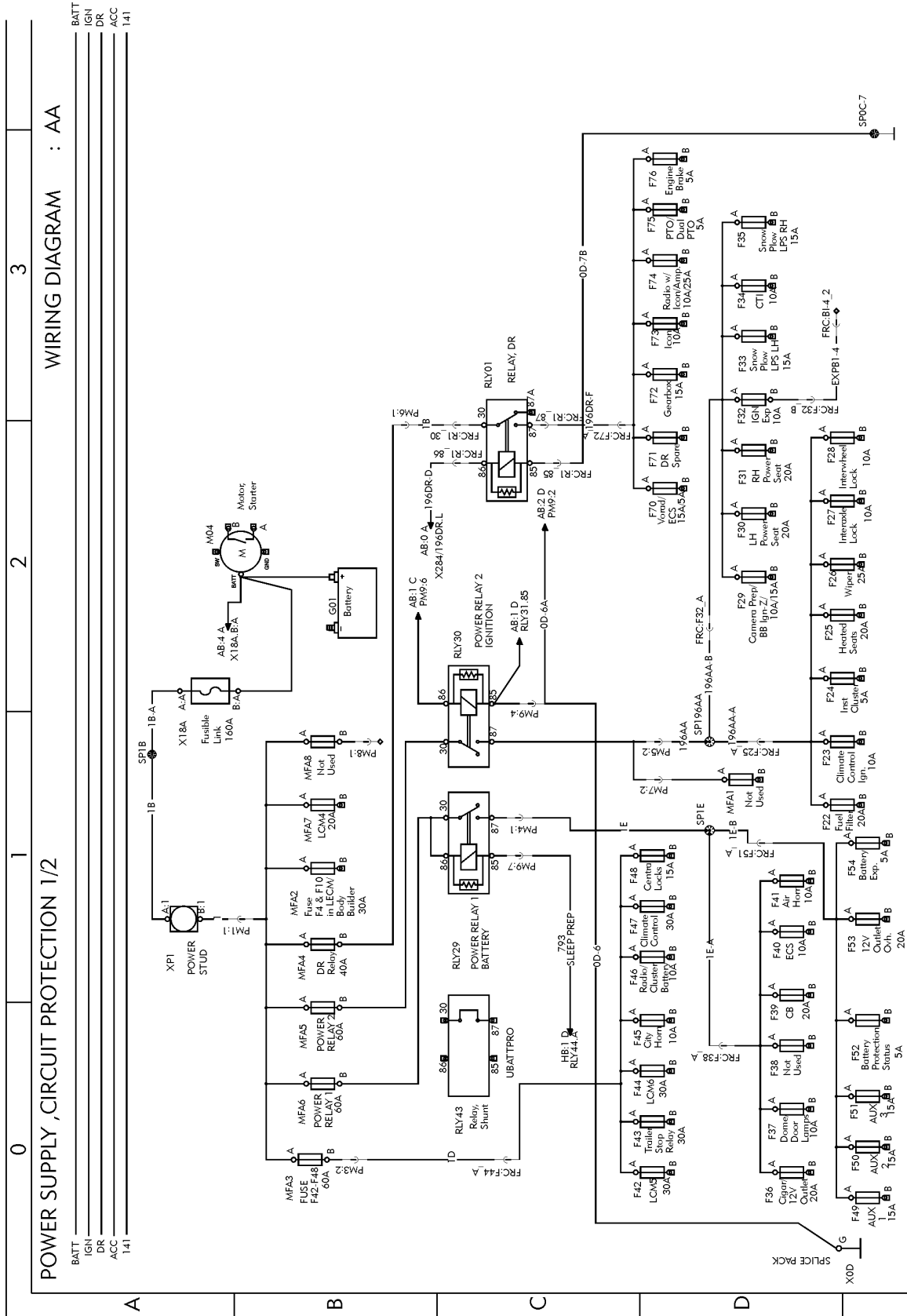

Fig. 1: AA

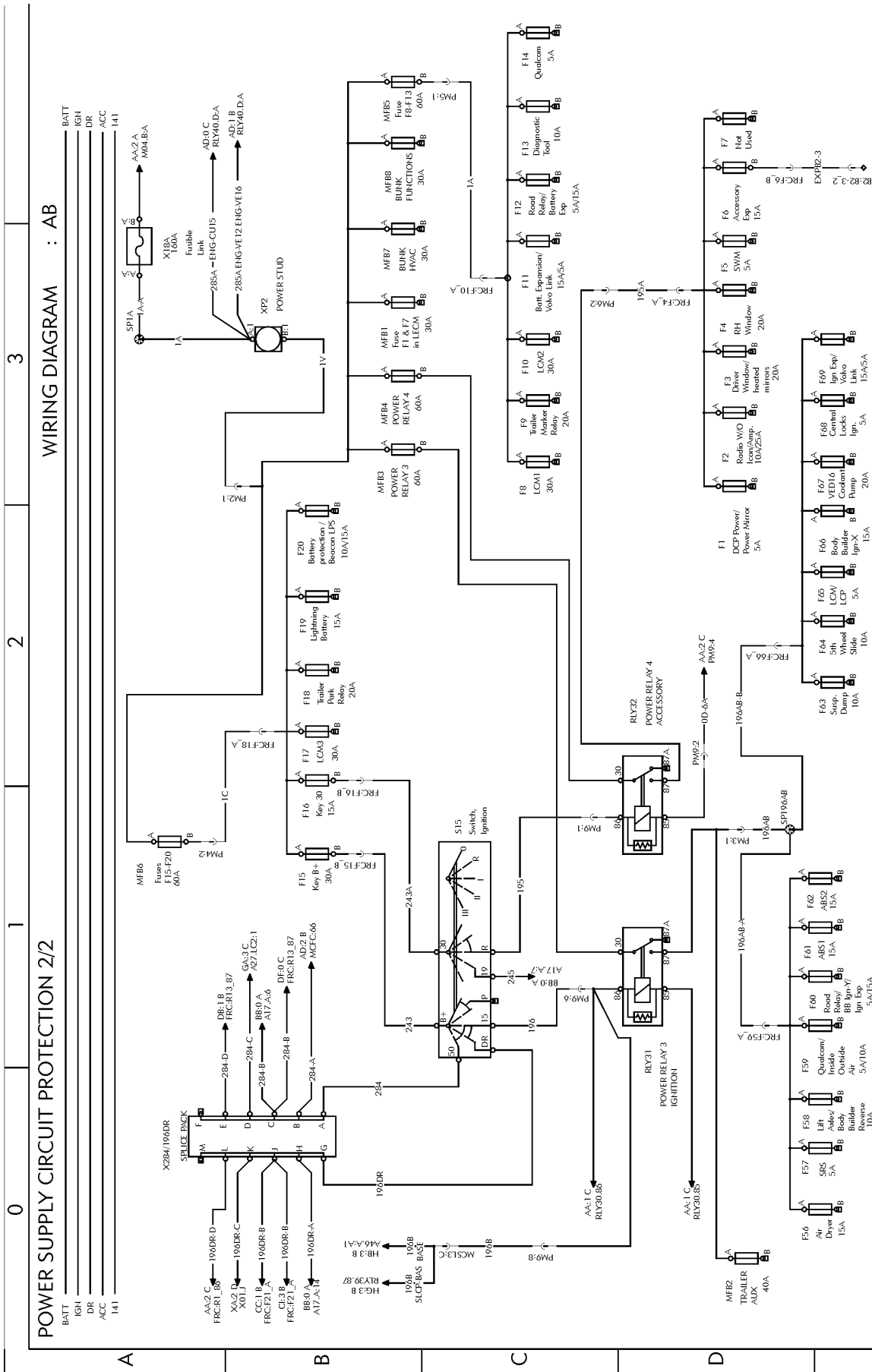

Fig. 2: AB

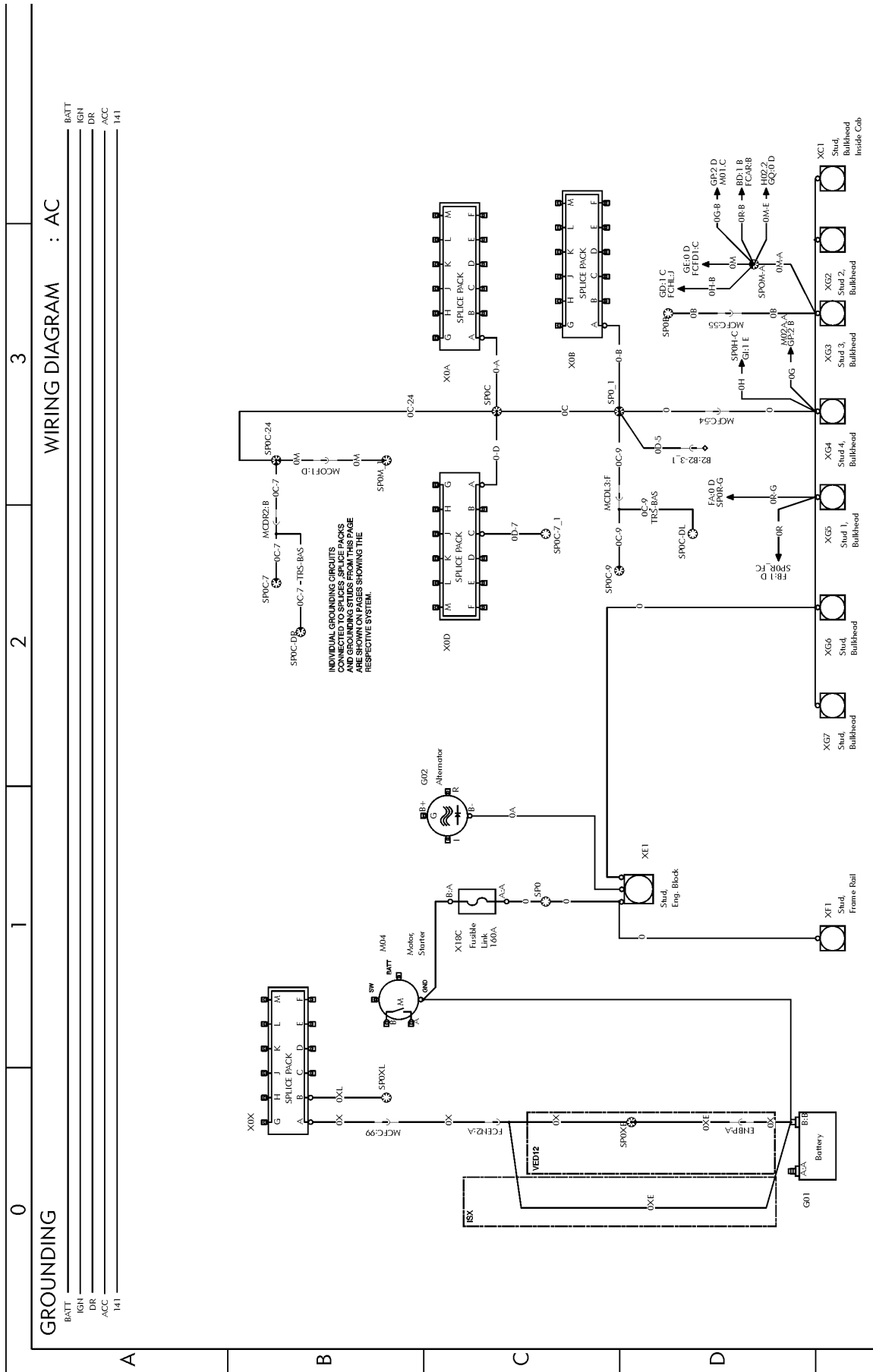

Fig. 3: AC