

Volvo Supplement V70 08 Xc70 08 S80 07 2009 Wiring Diagram

Full download: <http://manualplace.com/download/volvo-supplement-v70-08-xc70-08-s80-07-2009-wiring-diagram/>



VOLVO V70 (08-), XC70 (08-) & S80 (07-)

WIRING DIAGRAM 2009 SUPPLEMENT



TP 39138202 LATE DESIGN

Vehicles with SRS (Airbag)/SIPS bag/ IC (Inflatable curtain)

Warning!

Extra caution must be exercised when working on vehicles equipped with SRS/SIPS bag/IC in order to avoid:

1. Personal injuries when performing repair work.
2. Damage or malfunction of the SRS/SIPS bag/IC system.

Work involving the SRS/SIPS bag/IC systems or other components in the vehicle that may affect the SRS/SIPS bag/IC systems must always be performed by an authorized Volvo workshop.

In case of doubt, consult the SRS and SIPS bag/IC service manual.

Is the vehicle equipped with SRS/SIPS bag/IC?

Vehicles with SRS are most easily recognized by the letters SRS in the center of the steering wheel. If the vehicle also has a passenger side airbag, the letters SRS are stamped on the dashboard above the glove compartment. SRS vehicles from 1993 and onward also have explosive seat belt tensioners. SIPS bags are only installed on SRS vehicles from 1995 and onward. SIPS bag decals are located on the windshield and seat compartment. Vehicles with IC can be recognized by the letters IC on the C/D panel (4 door) or the B panel (5 door).

General recommendations

- Be especially careful when working on or around SRS, SIPS, and IC components.
- Make sure that no wires are pinched, frayed, or pierced.
- Never fit accessories by the sensors.
- Where applicable, work on the steering wheel, steering shaft, or steering gear must be done in accordance with the methods in the SRS section of VIDA.
- Certain components of the aforementioned systems must be grounded while working. Read the appropriate sections in VIDA.
- Install no accessories in the areas between the A and B-posts, the B and C-posts, and the C and D-posts.

Test terminal

Fuse in cargo compartment auxiliary fuse box

Changes implemented up to and including May 2008

Any changes made to the vehicle after this date are not included in the manual. If necessary, refer to service bulletins.

Volvo models are sold in versions adapted for different markets. These adaptations depend on factors such as legal requirements, taxation, and market demands.

This manual may therefore include illustrations and text that do not apply to the vehicles in your country.

Order number **TP 39138202**

Can be ordered from Technical Information Shop (TIS)

at www.volvocarstechinfo.ford.com/vss

We retain the right to make modifications.

Table of Contents

Explanations	4
How to use the wiring diagrams 1:2.....	5
Electrical distribution 1:2	7

Fuses

Engine compartment electrical center F1-F7.....	9
Engine compartment distribution box F9-F24.....	10
Engine compartment distribution box F25-F30.....	11
Engine compartment distribution box F31-F37.....	12
Engine compartment distribution box F38.....	13
Engine compartment electrical center F39-F44.....	14
Central Electronic Module (CEM) F1 - F11.....	15
Central Electronic Module (CEM) F13 - F19.....	16
Central Electronic Module (CEM) F20 - F28.....	17
Rear electrical center FA1-FA12	18
Distribution box in cargo compartment FB1-FB12.....	19
Rear electrical center FD1-FD7	20
Battery PF1-PF2.....	21

Relays

Relays in the engine compartment R2.....	22
Relays in the engine compartment R8-R9.....	23
Relays in the engine compartment R10-R13.....	24
Cargo compartment.....	25
Distribution box in cargo compartment RA1-RD1.....	26
Central Electronic Module (CEM).....	27

Ground connections

Overview.....	28
31/2 - 31/6	29
31/7 - 31/10	30
31/15 - 31/47	31
31/66 - 31/83	32
31/84 - 31/INFOT.....	33

Control modules

Overview locations.....	34
Overview designations.....	35
Central Electronic Module (CEM) 1:3	36
Data communication high speed CAN.....	39
Data communication high speed CAN, 4-Cyl.	40
Data communication intermediate speed CAN, LHD.....	41
Data communication intermediate speed CAN, RHD	42
Data communication, LIN 1:2	43
Data communication MOST.....	45
Steering Wheel Module (SWM)	46

Group 23 Fuel system

Engine management system 5-Cyl. Diesel EURO5 1:3	47
---	----

Group 26 Cooling system

Cooling fan 5-Cyl. Diesel EURO5.....	50
--------------------------------------	----

Group 27 Engine controls

Cruise control 5-Cyl. Diesel EURO5.....	51
---	----

Group 32 Alternator and voltage regulator

Power supply	52
--------------------	----

Group 33 Starting system

Starting system	53
-----------------------	----

Group 35 Lighting

Interior lighting, LHD 1:2	54
Interior lighting, RHD 1:2.....	56

Group 36 Additional electrical equipment

Keyless vehicle 1:2	58
---------------------------	----

Group 39 Other

Audio Premium 1:3	60
-------------------------	----

Group 43 Transmission

Transmission M66.....	63
Automatic transmission MPS6.....	64
Climate control system 5-Cyl. Diesel EURO5 1:2.....	65

Connectors..... 67

Branching points72

Cable harness routing in vehicle

Harness engine, Diesel.....	79
Tunnel harness	79

Component illustrations80

Index103

List of components 1:3104

Explanations

Abbreviations

Groups

Group 23	= Fuel system
Group 26	= Cooling system
Group 27	= Engine controls
Group 32	= Alternator and voltage regulator
Group 33	= Starting system
Group 35	= Lighting
Group 36	= Additional electrical equipment
Group 37	= Wiring and fuses
Group 38	= Instruments
Group 39	= Other
Group 43	= Transmission
Group 59	= Brake system
Group 64	= Steering
Group 83	= Doors and openings
Group 84	= Exterior decorative elements, etc.
Group 85	= Interior equipment
Group 87	= Climate control system
Group 88	= Internal equipment

Ignition switch symbols

X	= Accessories (audio position)
S	= Powered upon insertion of key
15	= Contact remains connected during start
15I	= Contact is broken while starting
30	= Constant power from the battery
50	= Start

Countries/Markets

A	= Austria
AUS	= Australia
B	= Belgium
CDN	= Canada
CH	= Switzerland
D	= Germany
DK	= Denmark
E	= Spain
EU/OS	= Markets outside USA and Canada
FIN	= Finland
GB	= Great Britain
ISR	= Israel
J	= Japan
KOR	= Korea
N	= Norway
NL	= Netherlands
S	= Sweden
USA	= United States of America
WEU	= Western Europe

Other

ACC	= Adaptive Cruise Control
Ag	= Silver plated
Au	= Gold plated
AUTO	= Automatic transmission
BLIS	= Blind spot information system
CAN	= CAN communication
DPY	= Display
ECC	= Electronic climate control system
ETA	= Engine throttle body
EXC	= Exclusive
GDL	= Gas discharge lamp
HISPEED	= High speed data bus
IR	= Infrared sensor
LIN	= LIN communication
LH	= Left-hand side
LHD	= Left-hand drive
MAN	= Manual transmission
MEMORY	= Memory driver's seat
MIDSPEED	= Midspeed data bus
MMS	= Mass Movement Sensor
PETROL	= Gasoline
RH	= Right-hand side
RHD	= Right-hand drive
SCR	= Screened
SRS	= Airbag
T	= Turbocharged engine
W/O	= Without
2WD	= Two-wheel drive
4CYL, I4	= 4-cylinder engine
5CYL, I5	= 5-cylinder engine
6CYL, I6	= 6-cylinder engine
8CYL, V8	= 8-cylinder engine

Colors

BK, SB	= Black
BN	= Brown
BU, BL	= Blue
GN	= Green
GY, GR	= Gray
LGN	= Light Green
NL	= Natural
OG, OR	= Orange
PK, P	= Pink
RD, R	= Red
VT, VO	= Violet
WH, W	= White
YE, Y	= Yellow

How to use the wiring diagrams 1:2

The descriptions below apply in general to all wiring diagram manuals, although not all sections are necessarily contained in this manual.

A. Component designation

Every component has a component designation that consists of two parts.

The first part is a type number that describes the type of component in question, for example 3/xx.

The second part of the designation is a serial number, e.g. x/2.

Together, this constitutes a component designation, e.g. 3/2.

At the end of the manual is a list of components, where, with the help of the component designation, you can read off the name of the component, for example, 3/2 = light switch.

List of type numbers

The list shows which type of component that respective type numbers refer to, for example, 3/x = switch, 6/x = electric motor, etc.

1	Battery
2	Relay
3	Switch
4	Control module
5	Driver information module
6	Electric motor
7	Sensor
8	Actuator
9	Heating element
10	Light
11	Fuse
15	Electrical distribution rail/box
16	Audio
17	Service/diagnostics
18	Contact reel
19	Meter
20	Ignition component/shunt
27	Optics
31	Ground connection
73	Branching point
74	Connector

B. Branching points

The wiring diagrams contain numbered branching points, for example 73/5035.

This manual contains a section with a list of branching points. This list shows all the components that are connected to each branching point.

The location of the branching points is shown in the "Cable harness routing in vehicle" section.

C. Connectors

Connectors provide a bridge between two cable harnesses and are described in the "Connectors" section.

D. Electrical distribution

Operation of the fuses and relays is shown in the "Electrical distribution" section.

E. Data communication

Today's cars contain CAN, LIN and MOST networks that transfer information. Connections to these networks are not shown in their entirety in the respective wiring diagram. Complete information on CAN, LIN and MOST communication is found in the section "Control modules".

F. Abbreviations

A number of different abbreviations are used in the manual. These are explained in the section "Abbreviations".







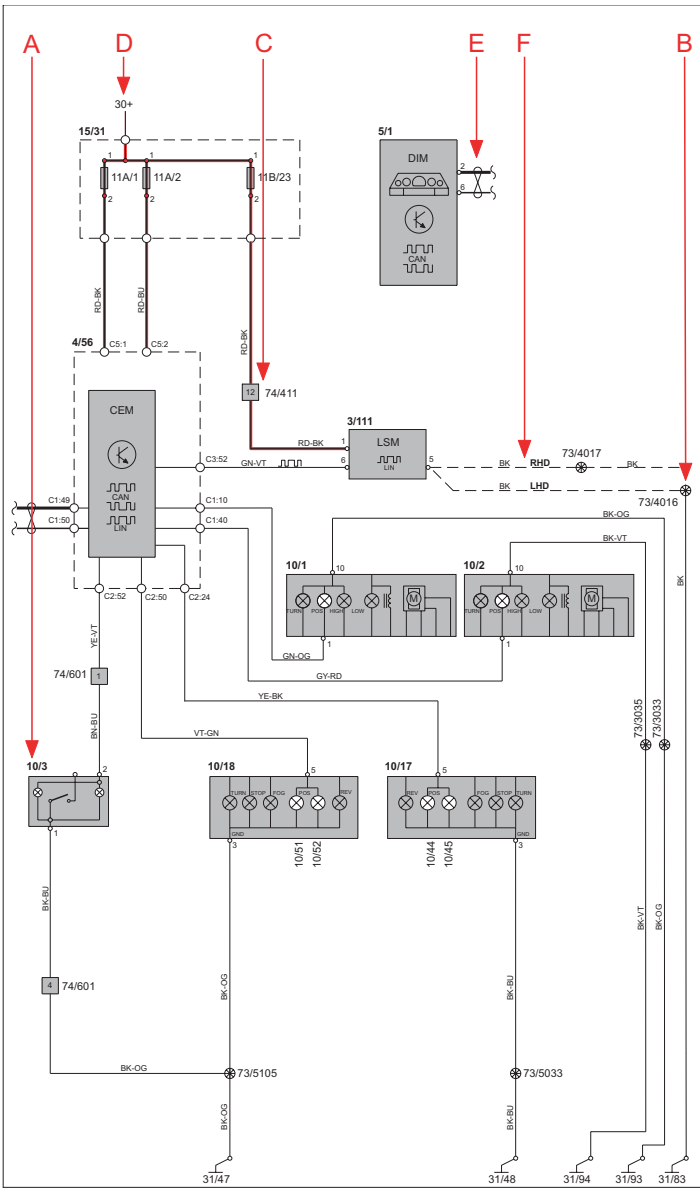



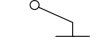

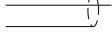

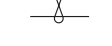

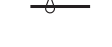

G. Component location

The end of the manual contains a section that describes component appearance and location in numerical order.

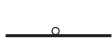
How to use the wiring diagrams 2:2

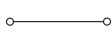
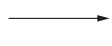

List of symbols

-  = System voltage
-  = Ground connection via wiring
-  = Ground connection in component/chassis
-  = Screened wire
-  = Junction point
-  = Twisted cable
-  = Electrical connection
-  = Variant
-  = CAN communication
-  = CAN high data signal (CAN H)
-  = CAN low data signal (CAN L)
-  = LIN communication
-  = LIN communication
-  = DIN cable, coaxial cable, etc.
-  = Data communication
-  = CAN communication
-  = MOST communication
-  = MOST communication
-  = Connection with distribution box
-  = Further connection to...
-  = Connector between cable harnesses
-  = Connector connected in component

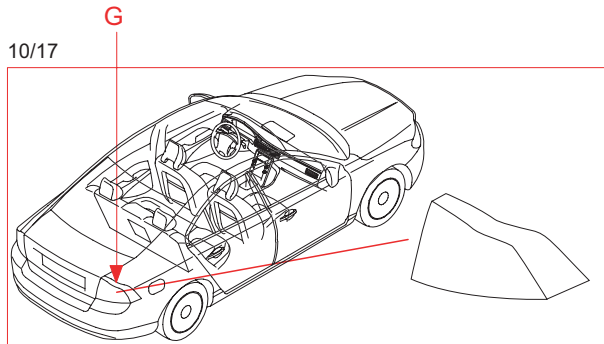

G029147

Electrical distribution 1:2

Overview, Electrical center and Cold zone in engine compartment

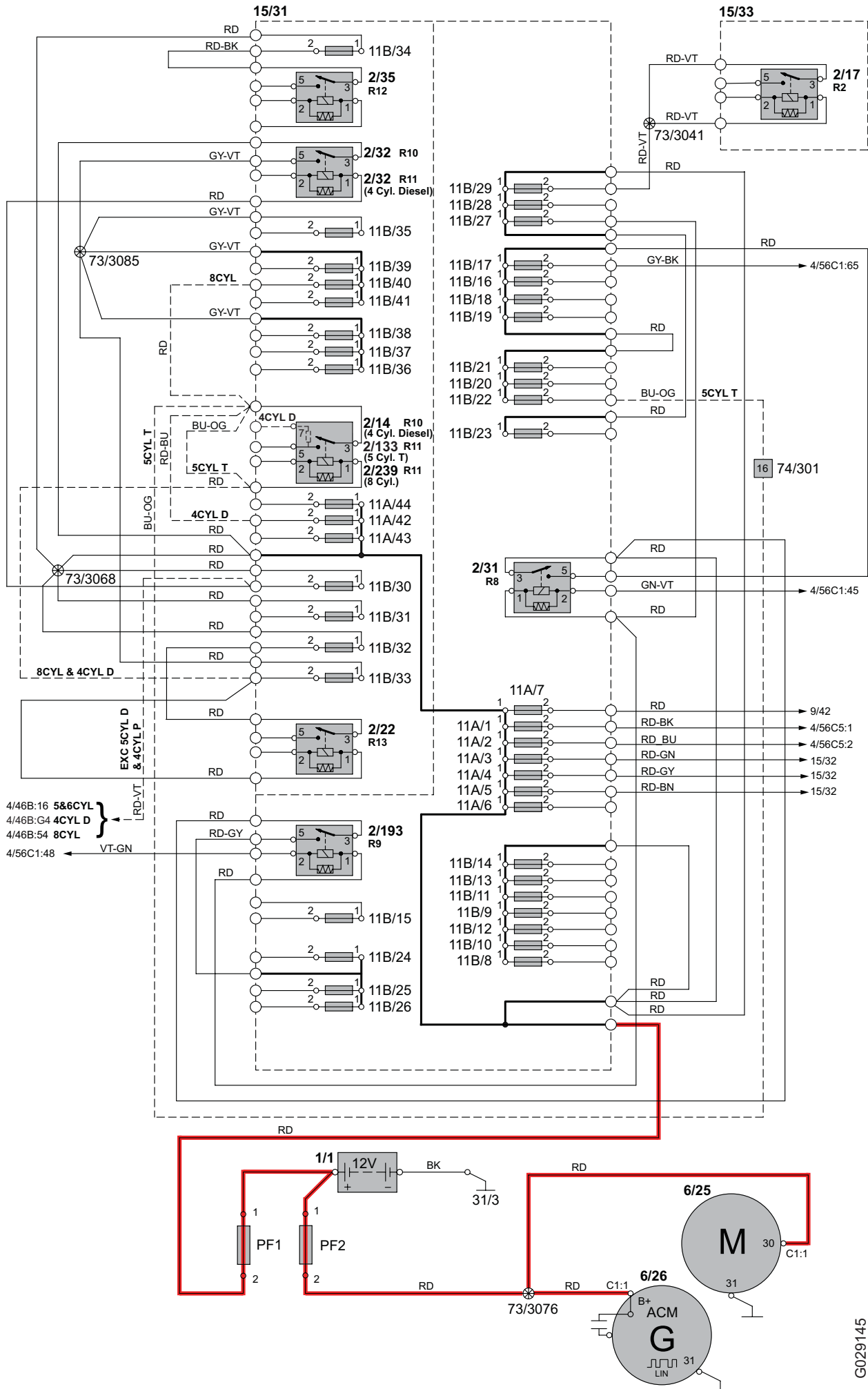

Electrical distribution 2:2

Overview, rear electrical center

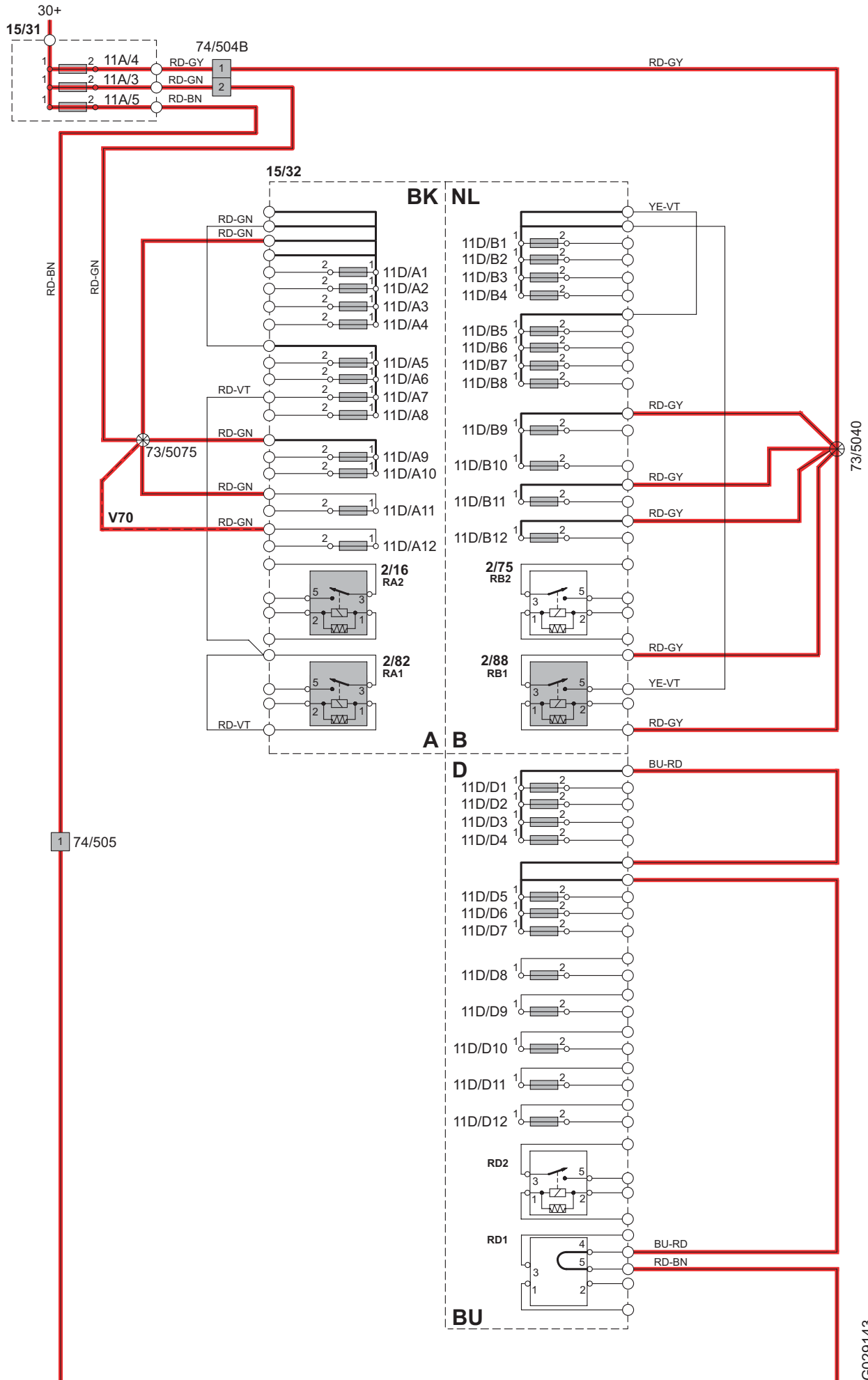

G029143

Fuses

Engine compartment electrical center F1-F7

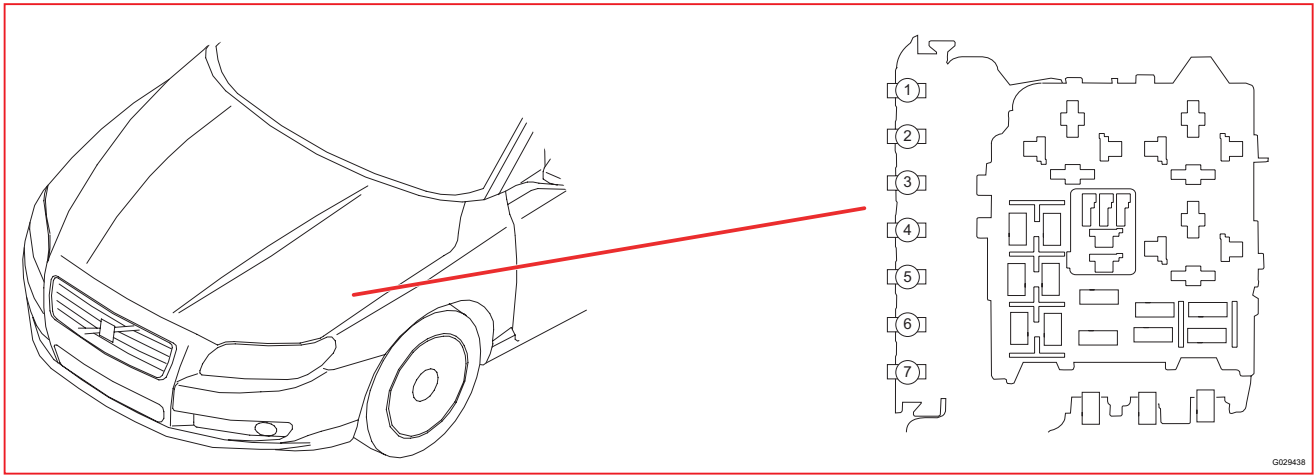

15/31 Distribution box in engine compartment

No.	No.	Fuse function	via	A
F1	11A/1	Main fuse for fuses in CEM	4/56	50
F2	11A/2	Main fuse for fuses in CEM	4/56	50
F3	11A/3	11D/A1-11D/A12 Fuses in cargo compartment 15/32	-	60
F4	11A/4	11D/B1-11D/B12 Fuses in cargo compartment 15/32	-	60
F5	11A/5	11D/D1-11D/D7 Fuses in cargo compartment 15/32	-	50
F7	11A/7	9/42 PTC-element	-	100
continues				

Fuses

Engine compartment distribution box F9-F24

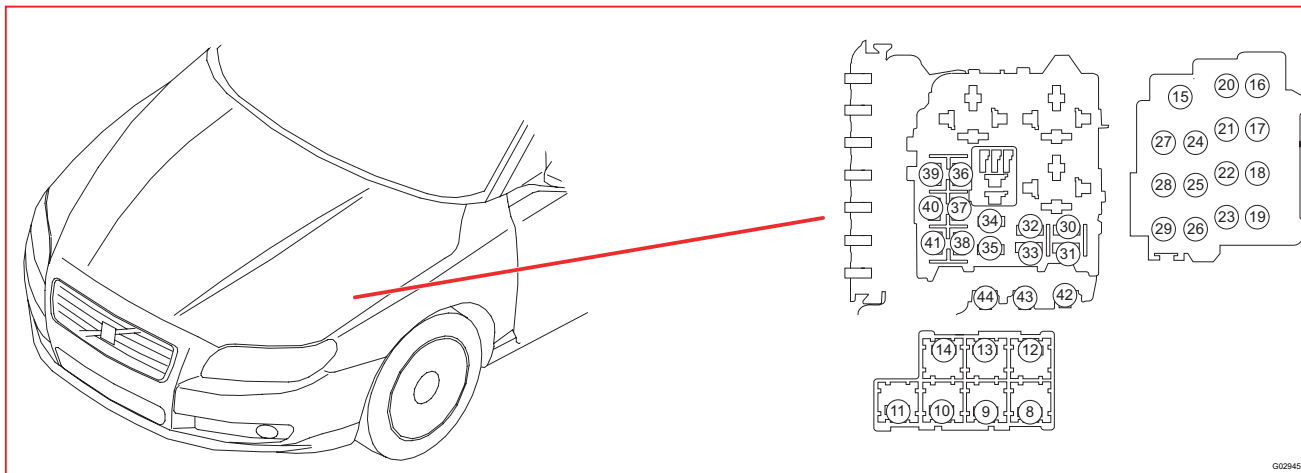

G029458

15/31 Distribution box in engine compartment

No.	No.	Fuse function	via	A
F9	11B/9	6/1 Wiper Motor Module (WMM)	-	30
F10	11B/10	4/7 Combustion Preheater Module (CPM) 4/106Control module, remote parking heater start	-	25
F11	11B/11	4/31 Passenger compartment fan control module 6/28 Motor, passenger compartment fan	-	40
F13	11B/13	4/16 Brake Control Module (BCM), pump	-	40
F14	11B/14	4/16 Brake Control Module (BCM), valves	-	20
F16	11B/16	4/118 Headlamp Control Module (HCM) 10/1 Lamp housing, front left 10/2 Lamp housing, front right	-	10
F17	11B/17	F2-F4 Fuses in the Central Electronic Module (CEM)	-	20
F18	11B/18	4/80 Forward Sensing Module (FSM) 7/203 Forward-aimed radar (FLR)	-	5
F19	11B/19	4/99 Electronic power steering control module	-	5
F20	11B/20	4/28 Transmission Control Module (TCM) 4/28B Transmission Control Module (TCM) MPS6 4/46 Engine Control Module (ECM) 4/9 Supplemental Restraint System Module (SRS)	-	10
F21	11B/21	9/43 Heated windshield washer nozzle, left 9/44 Heated windshield washer nozzle, right	-	10
F22	11B/22	6/114 Vacuum pump, 5-Cyl. Turbo	2/133	20
F23	11B/23	3/111 Light Switch Module (LSM)	-	5
F24	11B/24	6/104 High pressure headlight washer motor	-	15
continues				