

Volvo Supplement C30 S40 04 V50 C70 06 2009 Wiring Diagram

Full download: <http://manualplace.com/download/volvo-supplement-c30-s40-04-v50-c70-06-2009-wiring-diagram/>



VOLVO C30, S40 (04-), V50 & C70 (06-)

WIRING DIAGRAM 2009 SUPPLEMENT



TP 39139202 LATE DESIGN

Vehicles with SRS (Airbag)/SIPS bag/ IC (Inflatable Curtain)

Warning!

Extra caution must be exercised when working on vehicles equipped with SRS/SIPS bag/IC in order to avoid:

1. Personal injuries when performing repair work.
2. Damage or malfunction of the SRS/SIPS bag/IC system.

Work involving the SRS/SIPS bag/IC systems or other components in the vehicle that may affect the SRS/SIPS bag/IC systems must always be performed by an authorized Volvo workshop.

In case of doubt, consult the SRS and SIPS bag/IC service manual.

Is the vehicle equipped with SRS/SIPS bag/IC?

Vehicles with SRS are most easily recognized by the letters SRS in the center of the steering wheel. If the vehicle also has a passenger side airbag, the letters SRS are stamped on the dashboard above the glove compartment. SRS vehicles from 1993 and onward also have explosive seat belt tensioners. SIPS bags are only installed on SRS vehicles from 1995 and onward. SIPS bag decals are located on the windshield and seat compartment. Vehicles with IC can be recognized by the letters IC on the C/D panel (4 door) or the B panel (5 door).

General recommendations

- Be especially careful when working on or around SRS, SIPS, and IC components.
- Make sure that no wires are pinched, frayed, or pierced.
- Never install accessories by the sensors.
- Where applicable, work on the steering wheel, steering shaft, or steering gear must be done in accordance with the methods in the SRS section of VIDA.
- Certain components of the aforementioned systems must be grounded while working. Read the appropriate sections in VIDA.
- Install no accessories in the areas between the A and B posts, the B and C posts, and the C and D posts.

Test terminal

Data link connector in the passenger compartment.

Changes introduced up to and including June 2008

Any changes made to the vehicles after this date are not included in the manual. If necessary refer to service bulletins.

Volvo models are sold in versions adapted for different markets. These adaptations depend on factors such as legal requirements, taxation, and market demands.

This manual may therefore include illustrations and text that do not apply to the vehicles in your country.

Order number **TP 39139202**

Can be ordered from Technical Information Shop (TIS)
at www.volvocarstechinfo.ford.com/vss

We retain the right to make modifications.

Table of Contents

| | |
|--|---|
| Vehicles with SRS (Airbag)/SIPS bag/ IC (Inflatable Curtain)..... | 2 |
| Abbreviations..... | 4 |
| How to use the wiring diagram 1:2..... | 5 |
| Electrical distribution 1:2..... | 7 |

Fuses

| | |
|--|----|
| Engine compartment distribution box F1-F10..... | 9 |
| Engine compartment distribution box F11-F18..... | 10 |
| Engine compartment distribution box F20-F31..... | 11 |
| Engine compartment distribution box F32-F34..... | 12 |
| Engine compartment distribution box F35-FH1..... | 13 |
| Central Electronic Module (CEM) F43-F48..... | 14 |
| Central Electronic Module (CEM) F49-F61..... | 15 |
| Central Electronic Module (CEM) F62-F69..... | 16 |
| Central Electronic Module (CEM) F73-F85..... | 17 |
| Central Electronic Module (CEM) F86..... | 18 |
| Battery PF1-PF2..... | 19 |
| Fuses in holder..... | 20 |

Relays

| | |
|--|----|
| Ignition switch and relays..... | 21 |
| Distribution box in engine compartment R2-R14..... | 22 |
| Central electronic module (CEM) R15-R18..... | 23 |
| Central electronic module (CEM) R1-R11B..... | 24 |
| Other relays..... | 25 |

Ground connections

| | |
|------------------------------------|----|
| Overview..... | 26 |
| 31/3 - 31/10..... | 27 |
| 31/11 - 31/66..... | 28 |
| 31/66 cont. - 31/83..... | 29 |
| 31/84 - 31/110..... | 30 |
| 31/114 - 31/117..... | 31 |
| Ground connections in chassis..... | 32 |

Control modules

| | |
|----------------------------|----|
| Overview locations..... | 33 |
| Overview designations..... | 34 |

Group 23 Fuel system

| | |
|---|----|
| Engine management system, 4-Cyl. 1.6l 1:2..... | 35 |
| Engine management system, 4-Cyl. 1.8l & 2.0l 1:2..... | 37 |
| Engine management system, 5-Cyl. 1:2..... | 39 |
| Engine management system, 5-Cyl. Turbo 1:2..... | 41 |
| Engine management system Diesel, 4-Cyl. 2.0l MPS6 1:2..... | 43 |

Group 27 Engine controls

| | |
|----------------------------|----|
| Cruise control 4-Cyl. | 45 |
|----------------------------|----|

Group 39 Other

| | |
|--|----|
| Audio High Performance/Premium Sound C30/S40/V50 1:2..... | 46 |
| Audio High Performance/Premium Sound C70 1:2..... | 48 |

Group 87 Climate control system

| | |
|---|----|
| Climate control system, Diesel 1.6l & 2.0l 1:2..... | 50 |
|---|----|

Group 88 Internal equipment

| | |
|---|----|
| Supplemental Restraint System (SRS) C30/S40/V50 1:2..... | 52 |
|---|----|

Connectors..... 54

Branching points64

Cable harness routing in vehicle

| | |
|----------------------------------|----|
| Dashboard harness, LHD..... | 68 |
| Dashboard harness, RHD..... | 68 |
| Tunnel harness, C30/S40/V50..... | 69 |
| Tunnel harness, C70..... | 69 |

Component illustrations70

Index86

List of components 1:287

Explanations

Abbreviations

Groups

| | |
|----------|--------------------------------------|
| Group 23 | = Fuel system |
| Group 26 | = Cooling system |
| Group 27 | = Engine controls |
| Group 32 | = Alternator and voltage regulator |
| Group 33 | = Starting system |
| Group 35 | = Lighting |
| Group 36 | = Additional electrical equipment |
| Group 37 | = Wiring and fuses |
| Group 38 | = Instruments |
| Group 39 | = Other |
| Group 43 | = Transmission |
| Group 59 | = Brake system |
| Group 64 | = Steering |
| Group 83 | = Doors and openings |
| Group 84 | = Exterior decorative elements, etc. |
| Group 85 | = Interior equipment |
| Group 87 | = Climate control system |
| Group 88 | = Internal equipment |

Designations ignition switch

| | |
|-----|--|
| X | = Accessories (audio position) |
| S | = Powered upon insertion of key |
| 15 | = Contact remains connected during start |
| 15I | = Contact is broken while starting |
| 30 | = Constant power from the battery |
| 50 | = Start |

Countries/Markets

| | |
|-------|----------------------------------|
| A | = Austria |
| AUS | = Australia |
| B | = Belgium |
| CDN | = Canada |
| CH | = Switzerland |
| D | = Germany |
| DK | = Denmark |
| E | = Spain |
| EU/OS | = Markets outside USA and Canada |
| FIN | = Finland |
| GB | = Great Britain |
| ISR | = Israel |
| J | = Japan |
| KOR | = Korea |
| N | = Norway |
| NL | = Netherlands |
| S | = Sweden |
| USA | = United States of America |
| WEU | = Western Europe |

Other

| | |
|----------|-------------------------------------|
| ACC | = Accessories |
| Ag | = Silver plated |
| Au | = Gold plated |
| AUTO | = Automatic transmission |
| AWD | = All wheel drive |
| CAN | = CAN communication |
| D | = Diesel |
| DPY | = Display |
| ECC | = Electronic climate control system |
| ETA | = Engine throttle body |
| EXT. X | = Extended X-feed |
| GDL | = Gas discharge lamp |
| HISPEED | = High speed data bus |
| IR | = Infrared sensor |
| LIN | = LIN communication |
| LHD | = Left-hand drive |
| LOSPEED | = Low speed data bus |
| MAN | = Manual transmission |
| MEMORY | = Memory driver's seat |
| MMS | = Mass Movement Sensor |
| PETROL | = Gasoline |
| RHD | = Right-hand drive |
| SCR | = Screened |
| SRS | = Airbag |
| T | = Turbocharged engine |
| W/O | = Without |
| 2WD | = Two-wheel drive |
| 4CYL, I4 | = 4-cylinder engine |
| 5CYL, I5 | = 5-cylinder engine |

Colors

| | |
|--------|---------------|
| BK, SB | = Black |
| BN | = Brown |
| BU, BL | = Blue |
| GN | = Green |
| GY, GR | = Gray |
| LGN | = Light Green |
| OG, OR | = Orange |
| PK, P | = Pink |
| RD, R | = Red |
| VT, VO | = Violet |
| WH, W | = White |
| YE, Y | = Yellow |

How to use the wiring diagrams 1:2

The descriptions below apply in general to all wiring diagram manuals, although not all sections are necessarily contained in this manual.

A. Component designation

Every component has a component designation that consists of two parts.

The first part is a type number that describes the type of component in question, for example 3/xx.

The second part of the designation is a serial number, e.g. x/2.

Together, this constitutes a component designation, e.g. 3/2.

At the end of the manual is a list of components, where, with the help of the component designation, you can read off the name of the component, for example, 3/2 = light switch.

List of type numbers

The list shows which type of component that respective type numbers refer to, for example, 3/x = switch, 6/x = electric motor, etc.

| | |
|----|----------------------------------|
| 1 | Battery |
| 2 | Relay |
| 3 | Switch |
| 4 | Control module |
| 5 | Driver information module |
| 6 | Electric motor |
| 7 | Sensor |
| 8 | Actuator |
| 9 | Heating element |
| 10 | Light |
| 11 | Fuse |
| 15 | Electrical distribution rail/box |
| 16 | Audio |
| 17 | Service/diagnostics |
| 18 | Contact reel |
| 19 | Meter |
| 20 | Ignition component/shunt |
| 27 | Optics |
| 31 | Ground connection |
| 63 | Branching point |
| 64 | Connector |

B. Branching points

The wiring diagrams contain numbered junction points, e.g. 63/352.

This manual contains a section with a list of branching points. This list shows all the components that are connected to each branching point.

The location of the branching points is shown in the "Cable harness routing in vehicle" section.

C. Connectors

Connectors provide a bridge between two cable harnesses and are described in the "Connectors" section.

D. Electrical distribution

Operation of the fuses and relays is shown in the "Electrical distribution" section.

E. Data communication

Today's cars contain CAN and MOST networks that transfer information. Connections to these networks are not shown in their entirety in the respective wiring diagram. Complete information on CAN and MOST communication is found in the section "Control modules".

F. Abbreviations

A number of different abbreviations are used in the manual. These are explained in the section "Abbreviations".

G. Component location

There is a section at the end of the manual in which the appearance and location of components is described in numerical order.

How to use the wiring diagrams 2:2

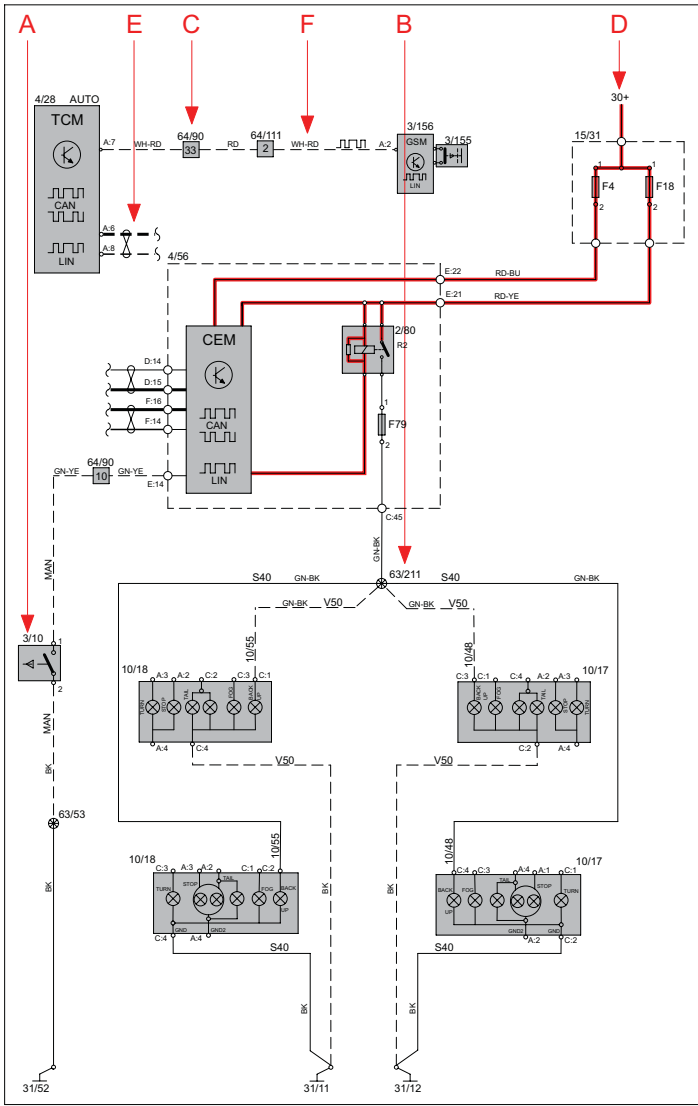

Explanation of symbols

- = System voltage
- = Ground connection via wiring
- = Ground connection in component/chassis
- = Screened wire
- = Junction point
- = Twisted cable
- = Electrical connection
- = Variant
- = CAN communication
- = CAN high data signal (CAN H)
- = CAN low data signal (CAN L)
- = LIN communication
- = LIN communication
- = DIN cable, coaxial cable, etc.
- = Data communication
- = CAN communication
- = MOST communication
- = MOST communication
- = Connection with distribution box
- = Further connection to.
- = Connector between cable harnesses
- = Connector connected in component

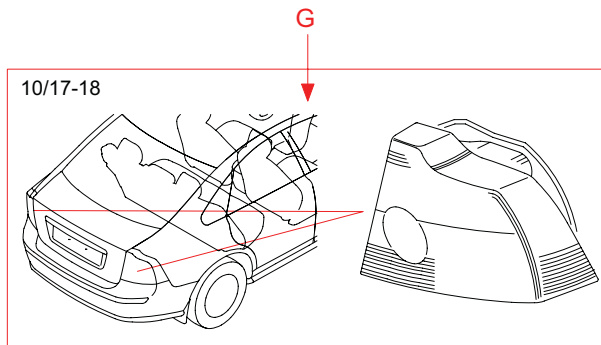

G030169

Electrical distribution 1:2 Overview

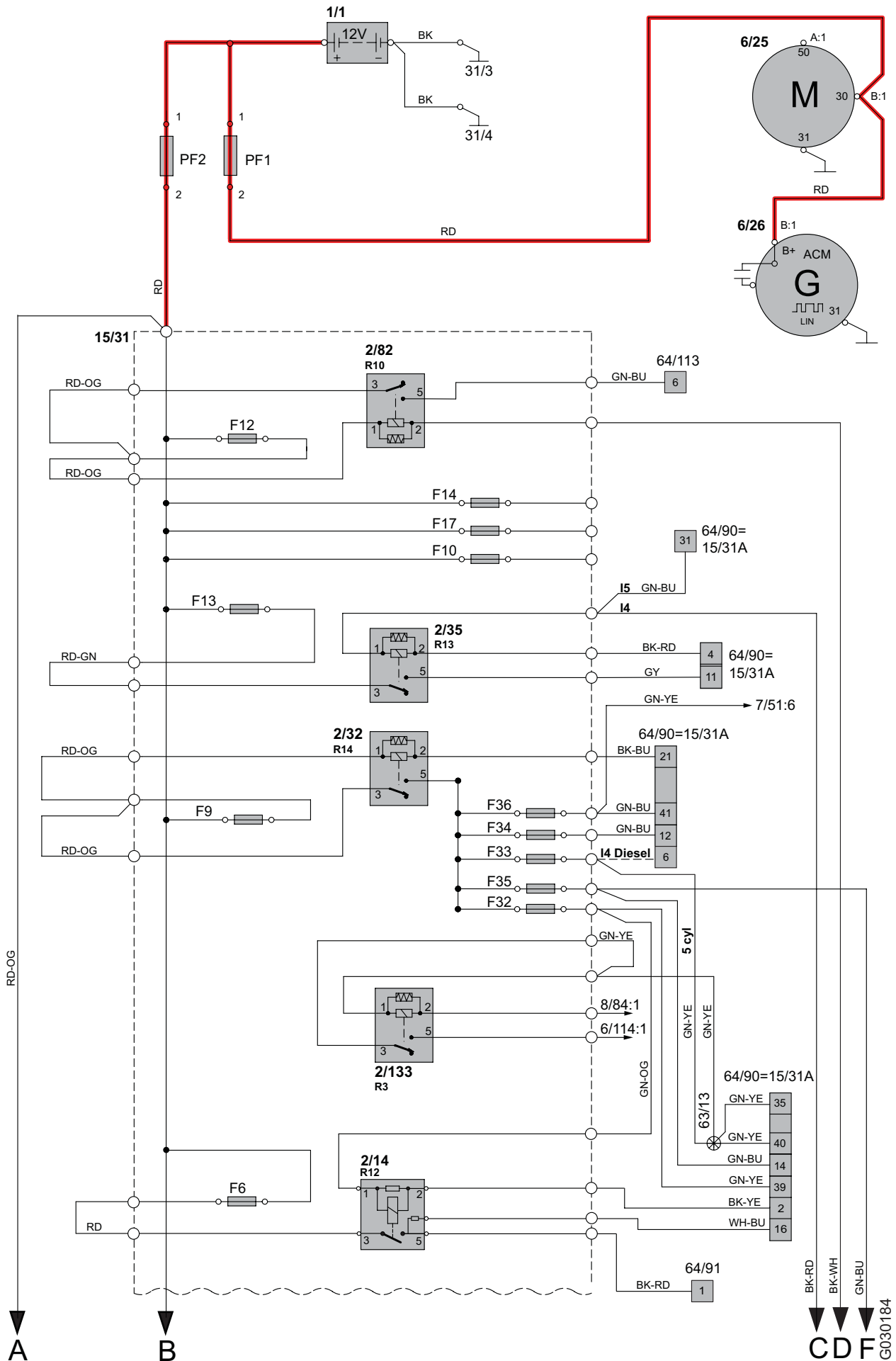

Electrical distribution 2:2

Overview

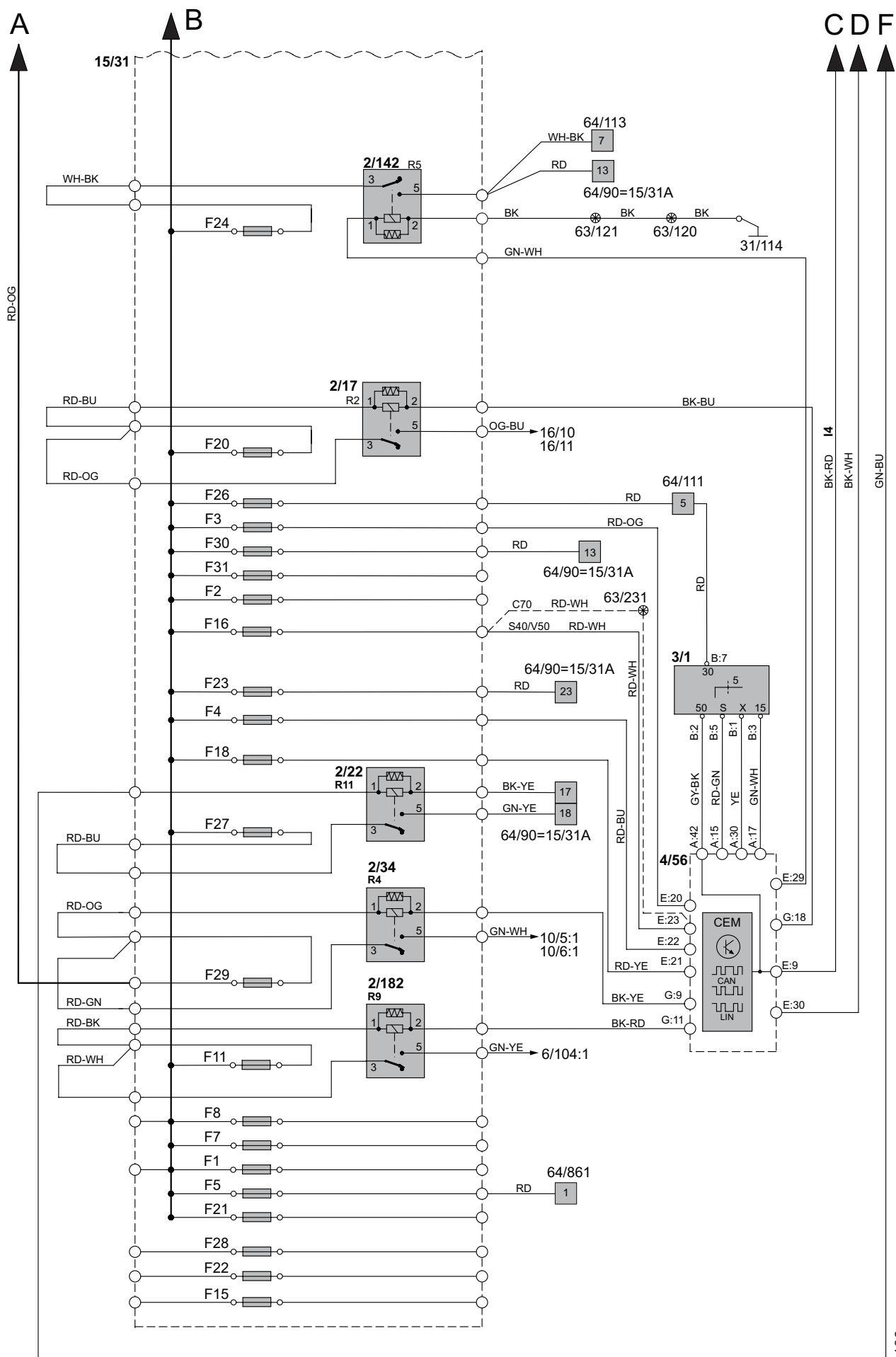

G030186