

Section: Body  
 Electrical  
 Ref. No. : BE-0025  
 Date : Jul., 2000  
 Page : 1 of 2

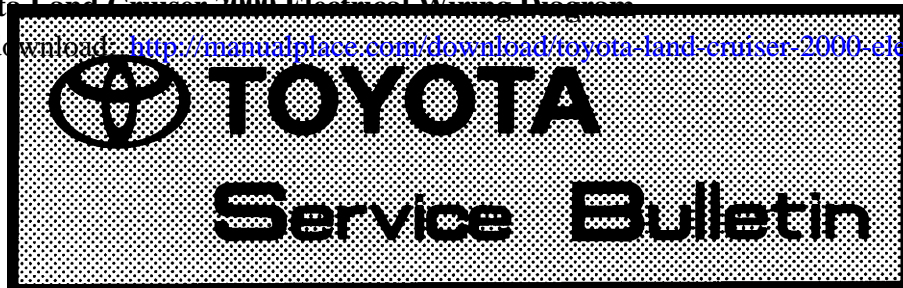

Area Application : Europe, Others(Saudi Arabia)

Model Name : LAND CRUISER, LAND CRUISER PRADO

Model Code : RZJ95, KDJ90, 95

Subject : ELECTRICAL WIRING DIAGRAM

This Service Bulletin is to inform you of the Electrical Wiring Diagram for the following systems due to the additions of the model equipped with 1KD-FTV engine and the engine immobiliser system for 3RZ-FE engine.

System	Location	
	LHD	RHD
Air Conditioner (Automatic 1KD-FTV)	49-4	47-4
Center Differential Lock (1KD-FTV w/VSC)	46-2	44-2
Charging (1KD-FTV)	41-3	39-3
Combination Meter (1KD-FTV)	48-2	46-2
Condenser Fan (Automatic 1KD-FTV)	49-2	47-2
Cruise Control (1KD-FTV)	42-10	40-10
ECT and A/T Indicator (1KD-FTV)	47-2	45-2
Engine Control (3RZ-FE w/Engine Immobiliser)	40-2	---
Engine Control (1KD-FTV)	42-2	40-2
Engine Immobiliser System (1KD-FTV)	42-12	40-12
Glow Plug (1KD-FTV)	42-1	40-1
Fuel Heater (1KD-FTV)	42-2	40-2
Illumination (1KD-FTV)	43-2	41-2
SRS (1KD-FTV)	44-2	42-2
Starting (1KD-FTV)	41-2	39-2
Viscous Heater (1KD-FTV)	46-3	44-3
VSC (1KD-FTV)	45-2	43-2



TOYOTA MOTOR CORPORATION

Overseas Service Division

The attached pages will be applied to the following manuals.

Pub. No.	Publication Name
EWD269F	LAND CRUISER / LAND CRUISER PLADO Electrical Wiring Diagram
EWD340F	LAND CRUISER / LAND CRUISER PLADO Electrical Wiring Diagram Supplement
EWD376F	LAND CRUISER / LAND CRUISER PLADO Electrical Wiring Diagram Supplement

Production Effective :

Frame No.	Production Date
---	From August, 2000

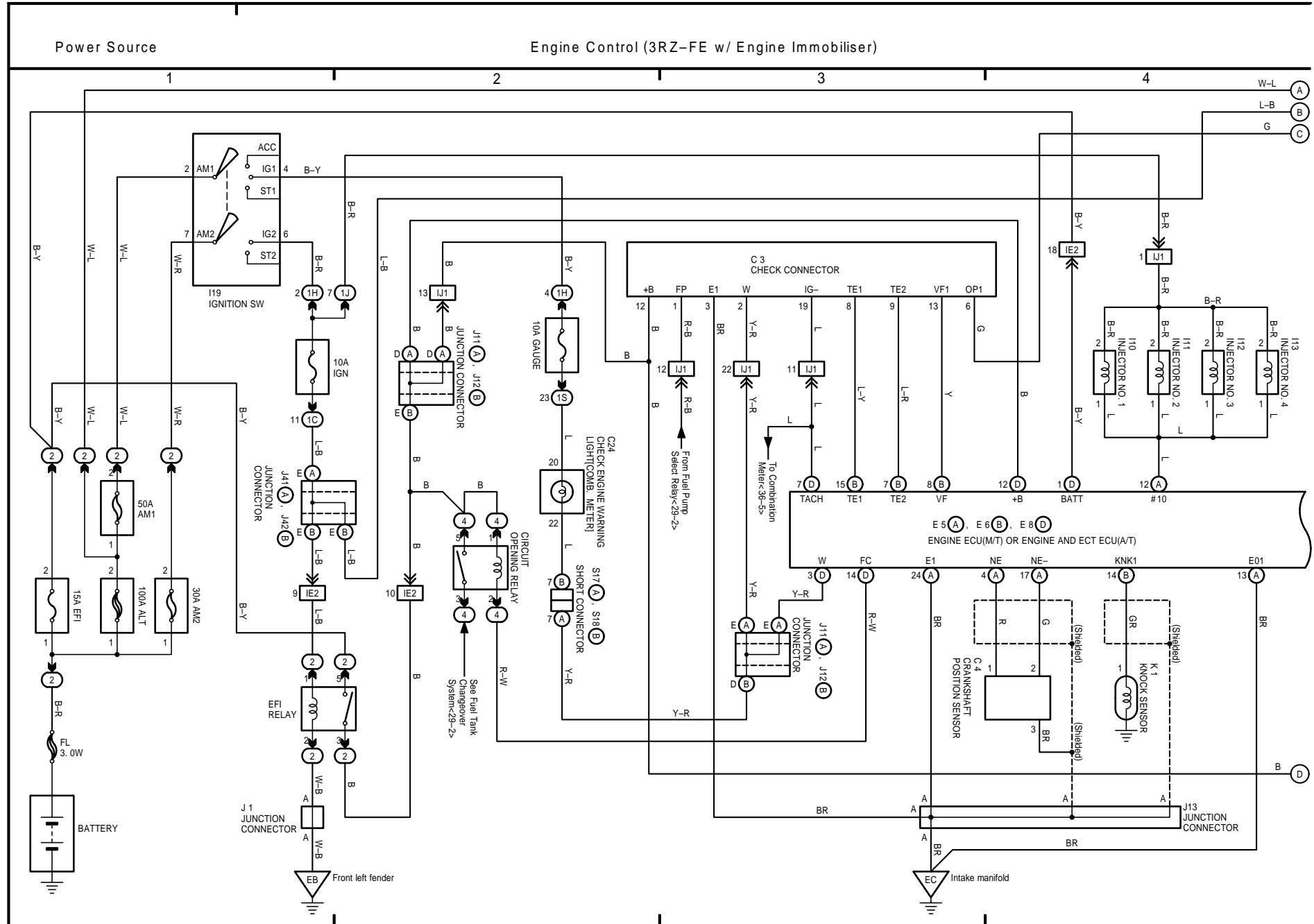

40 LAND CRUISER / LAND CRUISER PRADO (LHD) (Cont' d)

Engine Control (3RZ-FE w/ Engine Immobiliser)

