

# 7FBCU 15-55 INDEX

NAME	SECTION
<b>GENERAL</b>	<b>0</b>
<b>BATTERY</b>	<b>1</b>
<b>CONTROLLER</b>	<b>2</b>
<b>MULTI-DISPLAY FUNCTIONS</b>	<b>3</b>
<b>TROUBLESHOOTING</b>	<b>4</b>
<b>MOTOR</b>	<b>5</b>
<b>DRIVE UNIT</b>	<b>6</b>
<b>FRONT AXLE</b>	<b>7</b>
<b>REAR AXLE</b>	<b>8</b>
<b>STEERING</b>	<b>9</b>
<b>BRAKE</b>	<b>10</b>
<b>BODY</b>	<b>11</b>
<b>MATERIAL HANDLING SYSTEM</b>	<b>12</b>
<b>MAST</b>	<b>13</b>
<b>CYLINDER</b>	<b>14</b>
<b>OIL PUMP</b>	<b>15</b>
<b>OIL CONTROL VALVE</b>	<b>16</b>
<b>SAS FUNCTIONS</b>	<b>17</b>
<b>APPENDIX</b>	<b>18</b>

<Tillbaka till Index

## GENERAL

	Page		Page
EXTERIOR VIEWS .....	0-2	RECOMMENDED LUBRICANT QUANTITY & TYPES .....	0-18
VEHICLE MODEL .....	0-3	LUBRICATION CHART .....	0-19
FRAME NUMBER .....	0-4	PERIODIC MAINTENANCE .....	0-21
HOW TO USE THIS MANUAL .....	0-5	PERIODIC REPLACEMENT OF PARTS AND LUBRICANTS .....	0-26
EXPLANATION METHOD .....	0-5		
TERMINOLOGY .....	0-6		
ABBREVIATIONS .....	0-6		
OPERATIONAL TIPS .....	0-7		
JACK-UP POINT .....	0-8		
HOISTING THE VEHICLE .....	0-9		
CAUTION FOR TOWING .....	0-9		
ATTENTIVE POINTS ON SAS ....	0-10		
CIRCUIT TESTER .....	0-11		
STANDARD BOLT & NUT TIGHTENING TORQUE .....	0-13		
BOLT STRENGTH TYPE IDENTIFICATION METHOD .....	0-13		
TIGHTENING TORQUE TABLE .....	0-14		
PRECOAT BOLTS .....	0-15		
HIGH PRESSURE HOSE FITTING TIGHTENING TORQUE .....	0-15		
WIRE ROPE SUSPENSION ANGLE LIST .....	0-16		
SAFE LOAD FOR EACH WIRE ROPE SUSPENSION ANGLE .....	0-16		
COMPONENTS WEIGHT .....	0-17		

# EXTERIOR VIEWS

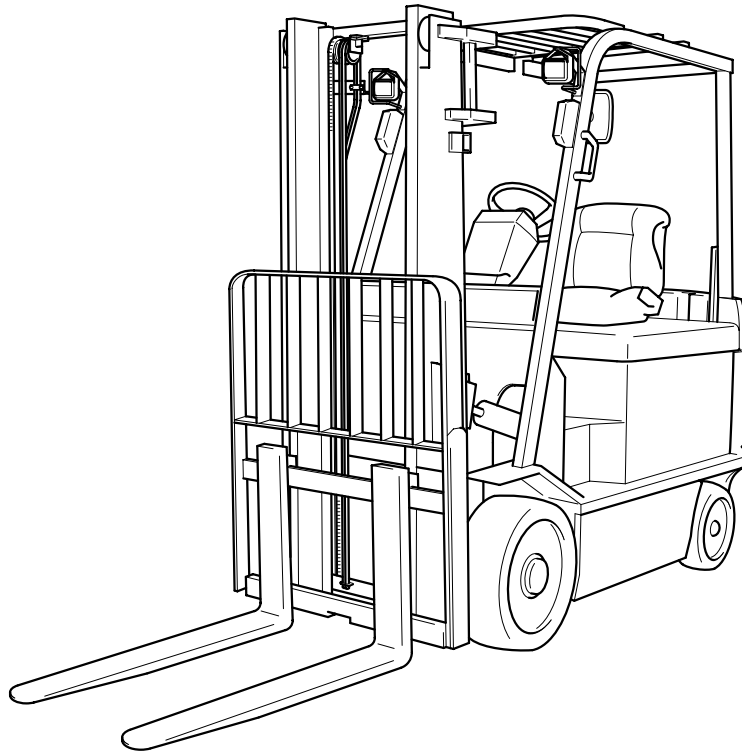

## VEHICLE MODEL

Model Code	Load Capacity	Vehicle Model	Voltage	Remarks
15	3000 lbs	7FBCU15	36V/48V	
		30-7FBCU15	↑	Dust proof
18	3500 lbs	7FBCU18	↑	
		30-7FBCU18	↑	Dust proof
20	4000 lbs	7FBCU20	↑	
		30-7FBCU20	↑	Dust proof
25	5000 lbs	7FBCU25	↑	
		30-7FBCU25	↑	Dust proof
		7FBCU25	↑	High capacity (battery compartment)
		30-7FBCU25	↑	<ul style="list-style-type: none"> <li>• Dust proof</li> <li>• High capacity (battery compartment)</li> </ul>
30	6000 lbs	7FBCU30	↑	
		30-7FBCU30	↑	Dust proof
32	6500 lbs	7FBCU32	↑	
		30-7FBCU32	↑	Dust proof
35	8000 lbs	7FBCU35	↑	
		30-7FBCU35	↑	Dust proof
45	10000 lbs	7FBCU45	↑	
		30-7FBCU45	↑	Dust proof
55	12000 lbs	7FBCU55	↑	
		30-7FBCU55	↑	Dust proof

## FRAME NUMBER

### Frame No. Punching Position

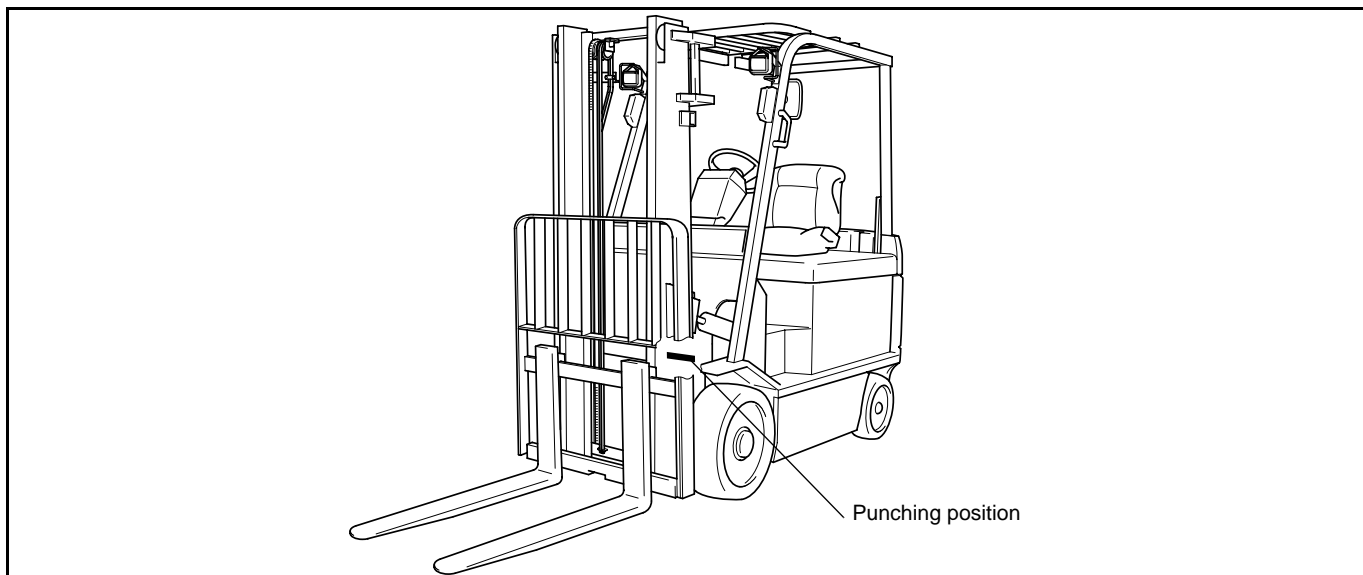

Vehicle Model	Punching format
7FBCU15	7FBCU18-60011
7FBCU18	* 7FBCU18Ⓢ60011
30-7FBCU15	307FBCU18-60011
30-7FBCU18	* 307FBCU18Ⓢ60011
7FBCU20	7FBCU25-60011
7FBCU25	* 7FBCU25Ⓢ60011
30-7FBCU20	307FBCU25-60011
30-7FBCU25	* 307FBCU25Ⓢ60011
7FBCHU25	7FBCHU25-60011
30-7FBCHU25	307FBCHU25-60011
7FBCU30	7FBCU32-60011
7FBCU32	* 7FBCU32Ⓢ60011
30-7FBCU30	307FBCU32-60011
30-7FBCU32	* 307FBCU32Ⓢ60011

Vehicle Model	Punching format
7FBCU35	7FBCU45-60011
7FBCU45	
30-7FBCU35	307FBCU45-60011
30-7FBCU45	
7FBCU55	7FBCU55-60011
30-7FBCU55	307FBCU55-60011

\*: EEC spec.

## HOW TO USE THIS MANUAL

### EXPLANATION METHOD

#### 1. Operation procedure

(1) The operation procedure is described in either pattern A or pattern B below.

Pattern A: Explanation of each operation step with illustration.

Pattern B: Explanation of operation procedure by indicating step numbers in one illustration, followed by explanation of cautions and notes summarized as point operations.

Example of description in pattern B

### DISASSEMBLY·INSPECTION·REASSEMBLY

Tightening torque unit T = N·m (kgf·cm) [ft·lbf]

- Step Nos. are partially sometimes omitted in illustrations.
- When a part requiring tightening torque instruction is not indicated in the illustration, the part name is described in the illustration frame.

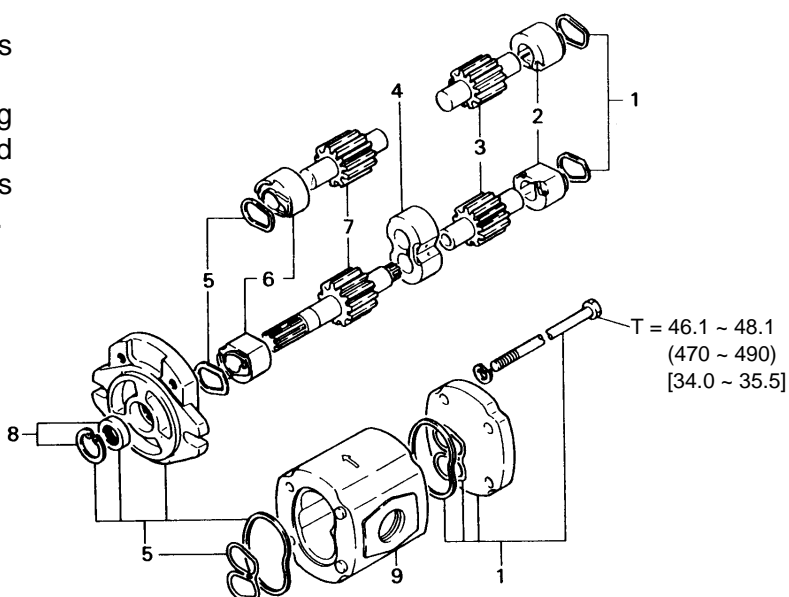

#### Disassembly Procedure

- 1 Remove the cover. **[Point 1]**
- 2 Remove the bushing **[Point 2]** ← Operation explained later
- 3 Remove the gear.

**Point Operations** Explanation of key point for operation with an illustration



#### **[Point 1]**

Disassembly:

Put a match mark when removing the pump cover.

#### **[Point 2]**

Inspection:

Measure the bushing inside diameter.

**Limit: 19.12 mm (0.7528 in)**

## 2. How to read components figures (Example)

- (1) The components figure uses the illustration in the parts catalog for the vehicle model. Please refer to the catalog for checking the part name.  
The number at the right shoulder of each components figure indicates the Fig. number in the parts catalog.

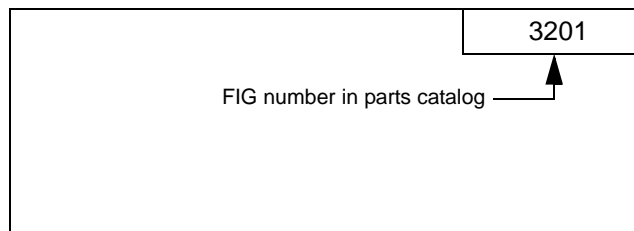

## 3. Matters omitted in this manual

- (1) This manual omits description of the following jobs, but perform them in actual operation:
- Cleaning and washing of removed parts as required
  - Visual inspection (partially described)

**TERMINOLOGY****Caution:**

**Important matters of which negligence may cause hazards on human body. Be sure to observe them.**

**Note:**

**Important items of which negligence may cause breakage or breakdown, or matters in operation procedure requiring special attention.**

Standard: Values showing allowable range in inspection and adjustment.

Limit: Maximum or minimum allowable value in inspection or adjustment.

**ABBREVIATIONS**

Abbreviation (code)	Meaning	Abbreviation (code)	Meaning
ASSY	Assembly	SAE	Society of Automotive Engineers (USA)
EHPS	Electronically controlled fully hydraulic power steering	SAS	System of active stability
FHPS	Fully hydraulic power steering	SST	Special service tool
LH	Left hand	STD	Standard
L/	Less	T =	Tightening torque
OPT	Option	OOT	Number of teeth (OO)
O/S	Oversize	U/S	Undersize
PS	Power steering	W/	With
RH	Right hand		

## OPERATIONAL TIPS

### 1. Safe operation

- (1) After jacking up, always support with wooden blocks or rigid stands.
- (2) When hoisting the vehicle or its heavy component, use wire rope(s) with a sufficient reserve in load capacity.
- (3) Always disconnect the battery plug before the inspection or servicing of electrical parts.

### 2. Tactful operation

- (1) Prepare the mechanic tools, necessary measuring instruments (circuit tester, megger, oil pressure gauge, etc.) and SSTs before starting operation.
- (2) Before disconnecting wiring, always check the cable color and wiring state.
- (3) When overhauling functional parts, complicated portions or related mechanisms, arrange the parts neatly to prevent confusion.
- (4) When disassembling and inspecting such a precision part as the control valve, use clean tools and operate in a clean location.
- (5) Follow the described procedures for disassembly, inspection and reassembly.
- (6) Replace, gaskets, packing and O-rings with new ones each time they are disassembled.
- (7) Use genuine Toyota parts for replacement.
- (8) Use specified bolts and nuts. Observe the specified tightening torque at the time of reassembly. (Tighten to the center of the specified tightening torque range.)  
If no tightening torque is specified, tighten the bolt or nut according to the standard tightening torque table.

### 3. Protection of functional parts

- (1) Thoroughly check each connector for any failure in or imperfect connection before reconnecting the battery plug after the end of vehicle inspection or maintenance.  
**Failure in or imperfect connection of connectors related to controllers, especially, may damage elements inside the controllers.**

### 4. Confirming defect status

Do not start immediate disassembly or replacement, but first confirm if such disassembly or replacement is actually needed.

### 5. Handling of waste fluid, etc.

When draining waste fluid from the vehicle, always receive it with an appropriate container.

Since careless or arbitrary discharge or disposal of oil, fuel, coolant, oil filter, battery or any other harmful substance may cause adverse affect to people or environmental destruction, sort each waste and always ask an authorized contractor for appropriate disposal.

### 6. Handling of electronic parts

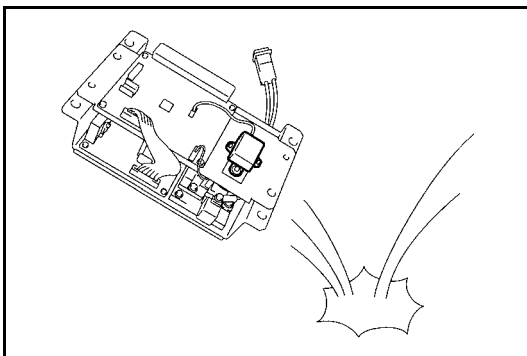

- (1) Never apply impacts to electronic parts such as a microcomputer or relay.
- (2) Never let electronic parts be exposed to a high temperature or humidity.
- (3) Do not touch connector pins since they may be deformed or be damaged due to static electricity.



## JACK-UP POINT

Strictly observe the following instructions when jacking up the vehicle.

- When a load is on the fork, unload it and park the vehicle on a flat floor. Be sure to avoid an inclined or rugged place.
- Use a jack with ample capacity and jack up the vehicle at the specified jack-up point. Jacking up at any other point will be dangerous.
- Never operate while the vehicle is held with a jack. Always support the frame with a wooden block after jacking up.
- In any case, never let a part of the body (including hands and feet) be under the jacked-up vehicle.

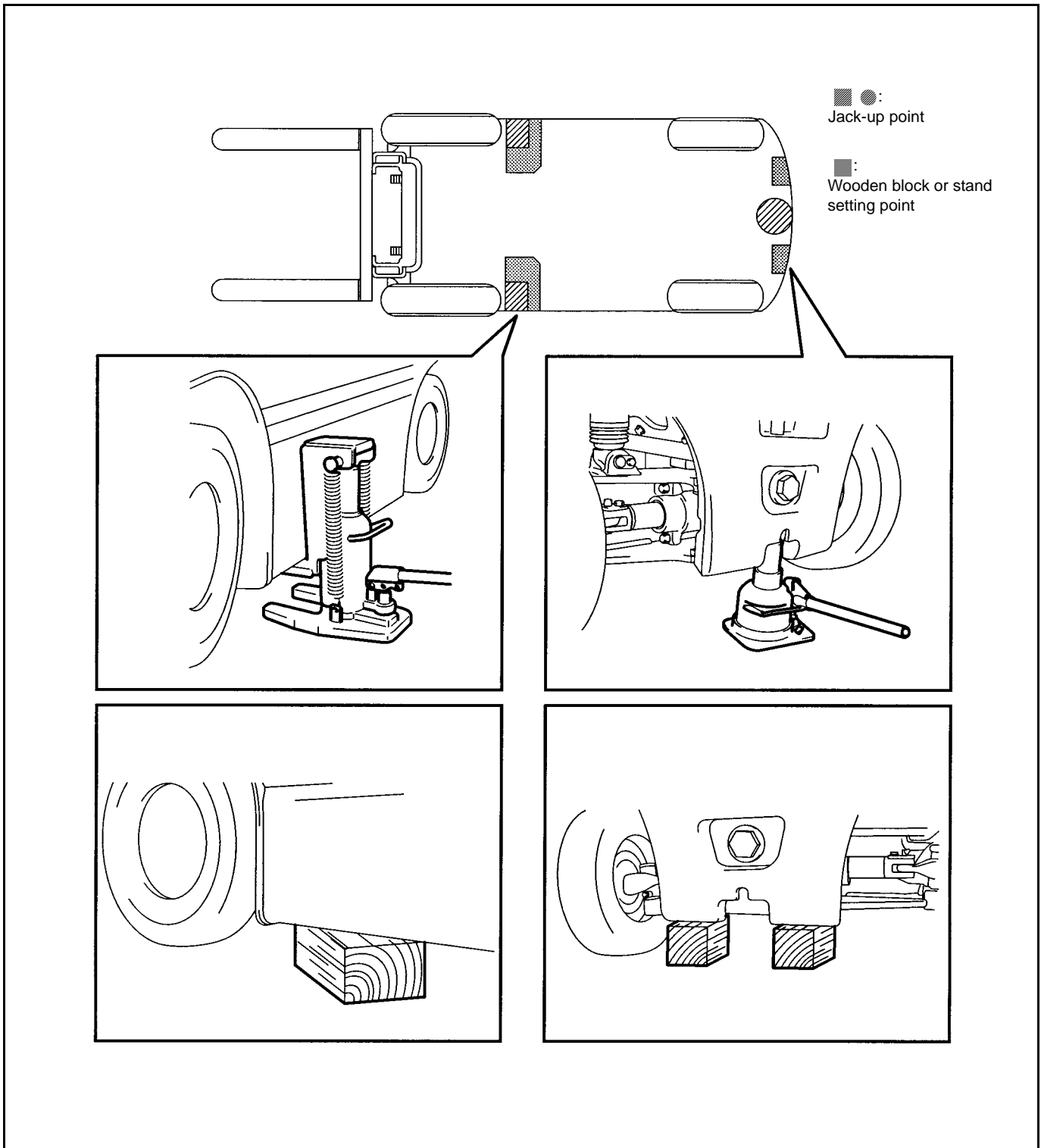

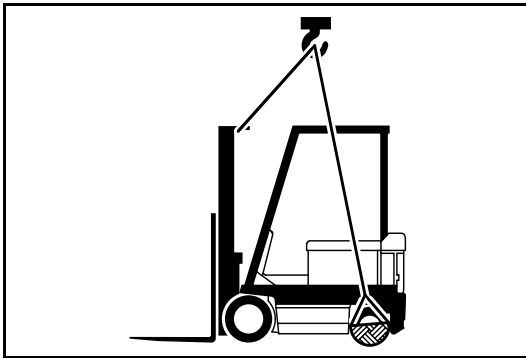

## HOISTING THE VEHICLE

When hoisting the vehicle, use the mast hook on the front of the vehicle and a wire net on the rear wheel.

### Caution:

- Use wire ropes having sufficient strength.
- Never hoist the forklift by the weight hook holes or head guard.

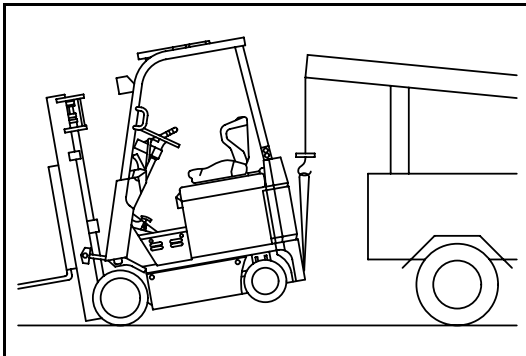

## CAUTION FOR TOWING

1. When towing the forklift, always lift the rear wheels away from the ground.
2. The traveling speed in towing must not exceed the maximum traveling speed of the forklift.
3. Always set the key switch to OFF and the direction switch to the neutral position before starting towing. In case of towing by connection with a wire rope with the operator on the forklift, however, set the key switch to ON (PS operation) and always set the direction switch to the neutral position.
4. Before towing, either remove the fork or take an action to prevent fork contact with the ground due to bounding.

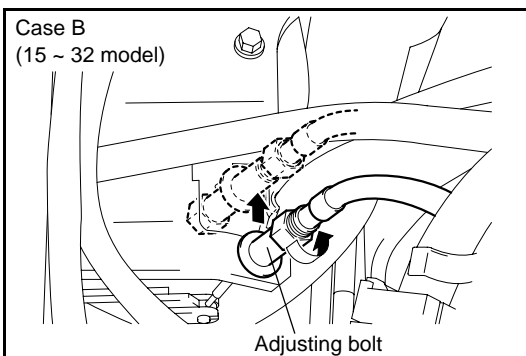
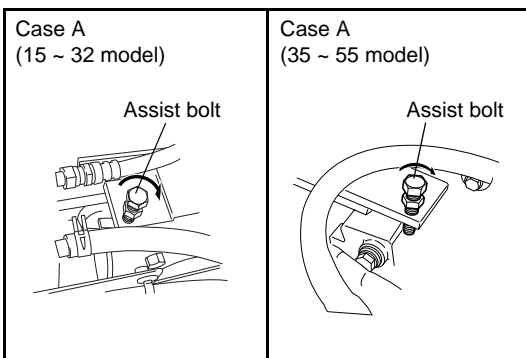
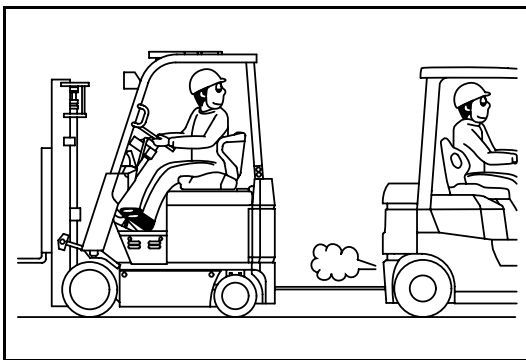

### Cautions for Deadman Brake Spec. Model

The brake exclusive to the deadman brake must be released before towing.

The deadman brake can be released in the two following ways. Select according to the situation.

- A. Releasing after battery removal
- B. Releasing with the battery installed

#### Case A:

1. Remove the battery.
2. Loosen the lock nut for the assist bolt for forced releasing of the brake, and tighten the assist bolt fully to release the brake.
3. Be sure to adjust after towing. (See Page 10-57, 58.)

#### Case B:

1. Remove the toe board.
2. Loosen the deadman brake cable adjusting bolt and free the cable from the cable clamp.

15 ~ 32 model:

Remove the PS controller first for easier operation.

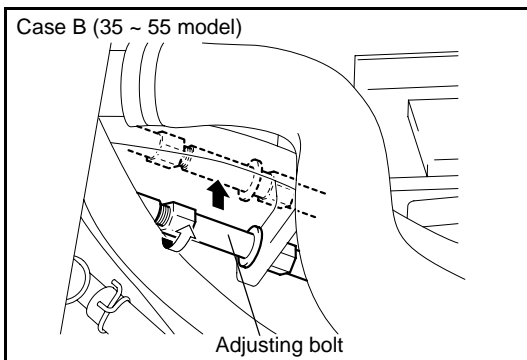

35 ~ 55 model:

Move the position of the pump motor No. 1 W/motor bracket first for easier operation.

3. Be sure to adjust after towing. (See Page 10-57, 58.)

## ATTENTIVE POINTS ON SAS

1. Reference should be made to separate manual "New Model Feature 7FBCU15 to 55 Pub. No.PU312" for the explanations of SAS functions and operations.
2. Read Section 17 "SAS Precautions for Repair" on Page 17-12 in this repair manual in advance.
3. Whenever the repair or replacement is performed to the place where relative to SAS function, machining procedure by which the SAS regain proper function must be performed. (See VOL.2 Page 3-54)
4. The warning on the SAS caution label must be confirmed when the modification or change is such as to change the original specification.  
If improper, change the label. (See Page 17-27)
5. Care should always be exercised for safety operation whenever you operate the truck.  
Make distinction between the SAS featured trucks and those of none, because the control features are different.
6. The SAS oil control valves comprise many precision valves. Since dirty or contaminated hydraulic oil will adversely affect the functions of these valves, always wash the parts clean at the time of installation after disassembly or for replacement of hydraulic parts (valves, piping, etc.). Periodic replacement of the hydraulic oil is very important.
7. Since this vehicle uses high-precision electronic devices, modification of electrical parts may cause faults. Always use genuine Toyota parts when replacing or installing electrical parts (auxiliary equipment, optional parts, etc.).

## CIRCUIT TESTER

Circuit testers are available in both the analog and digital types. They should be used selectively according to the purpose of measurement.

Analog type: This type is convenient for observing movement during operation, but the measured value should only be used for reference or rough judgement.

Digital type: Fairly accurate reading is possible, but it is difficult to observe the variation or movement.

### 1. Difference in measurement results with the digital type and analog type

- \* The result may be different between measurements with the analog type and digital type.

Always use a circuit tester according to its operation manual.

Cautions when the polarities are different between the analog type and digital type are described below.

#### (1) Analog circuit tester

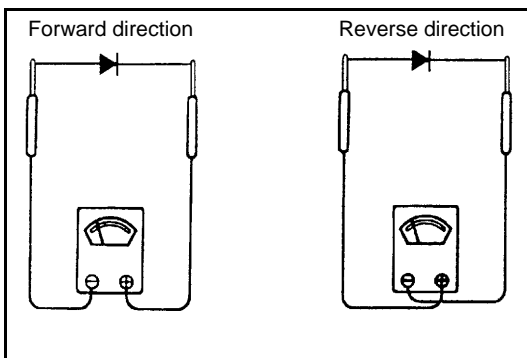

#### Measurement result example

Tester range:  $k\Omega$  range

	Analog type
Forward	Continuity exists
	11 $k\Omega$
Reverse	No continuity
	$\infty$

#### (2) Digital circuit tester

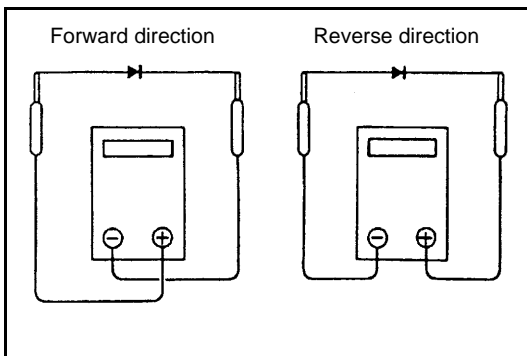

#### Measurement result example

Tester range:  $M\Omega$  range

	Digital type
Forward	No continuity
	1
Reverse	Continuity exists
	2 $M\Omega$

## 2. Difference in result of measurement with circuit tester

The circuit tester power supply voltage depends on the tester type. 1.5 V, 3.0 V or 6.0 V is used.

The resistance of a semiconductor such as a diode varies with the circuit tester power supply voltage.

The diode characteristics are shown in the figure below.

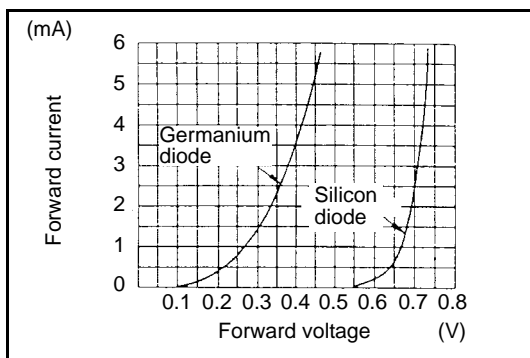

The resistance values of the same semiconductor measured with two types of circuit testers having different power supply voltages are different.

This manual describes the results of measurement with a circuit tester whose power supply voltage is 3.0 V.

## 3. Difference in measurement result by measurement range (analog type)

In the analog type circuit tester, changing the measurement range switches over the internal circuit to vary the circuit resistance. Even when the same diode is measured, the measurement result varies with the measurement range.

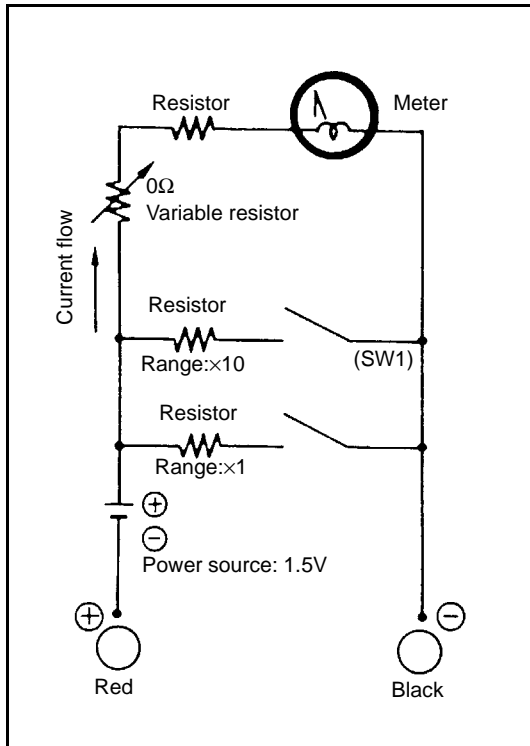

Always use the range described in the repair manual for measurement.







## STANDARD BOLT & NUT TIGHTENING TORQUE

Standard bolt and tightening torques are not indicated.  
Judge the standard tightening torque as shown below.

1. Find out the type of the bolt from the list below and then find the bolt tightening torque from the table.
2. The nut tightening torque can be judged from the mating bolt type.

### BOLT STRENGTH TYPE IDENTIFICATION METHOD

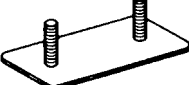
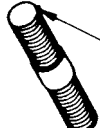
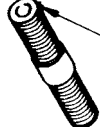

#### 1. Identification by bolt shape

	Shape and class	Class
Hexagon head bolt	 Bolt head No.	4 = 4T 5 = 5T 6 = 6T 7 = 7T 8 = 8T
	 No mark	4T
Hexagon flange bolt	 No mark	4T
Hexagon head bolt	 Two protruding lines	5T
Hexagon flange bolt	 Two protruding lines	6T
Hexagon head bolt	 Three protruding lines	7T
Hexagon head bolt	 Four protruding lines	8T
Welded bolt		4T
Stud bolt	 No mark	4T
	 Grooved	6T

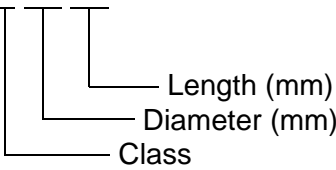
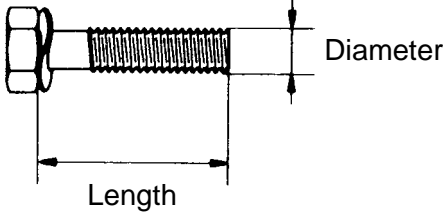
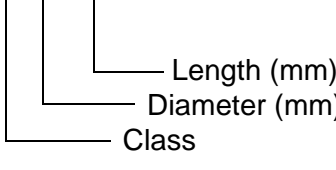
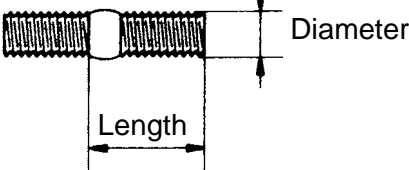
#### 2. Identification by part No.

Hexagon head bolt
<p>Parts No. 9 1 6 1 1 - 4 0 6 2 5</p>  
Stud bolt
<p>Parts No. 9 2 1 3 2 - 4 0 6 1 4</p>  

**TIGHTENING TORQUE TABLE**

Class	Diameter mm	Pitch mm	Specified torque					
			Hexagon head bolt 			Hexagon flange bolt 		
			N·m	kgf-cm	ft-lbf	N·m	kgf-cm	ft-lbf
4T	6	1.0	5.4	55	48 in-lbf	5.9	60	52 in-lbf
	8	1.25	13	130	9	14	145	10
	10	1.25	25	260	19	28	290	21
	12	1.25	47	480	35	53	540	39
	14	1.5	75	760	55	83	850	61
	16	1.5	113	1150	83	—	—	—
5T	6	1.0	6.4	65	56 in-lbf	7.5	75	65 in-lbf
	8	1.25	16	160	12	18	175	13
	10	1.25	32	330	24	36	360	26
	12	1.25	59	600	43	65	670	48
	14	1.5	91	930	67	100	1050	76
	16	1.5	137	1400	101	157	1600	116
6T	6	1.0	7.8	80	69 in-lbf	8.8	90	78 in-lbf
	8	1.25	19	195	14	21	215	16
	10	1.25	38	400	29	43	440	32
	12	1.25	72	730	53	79	810	59
	14	1.5	110	1100	80	123	1250	90
	16	1.5	170	1750	127	191	1950	141
7T	6	1.0	11	110	8	12	120	9
	8	1.25	25	260	19	28	290	21
	10	1.25	52	530	38	58	590	43
	12	1.25	95	970	70	103	1050	76
	14	1.5	147	1500	108	167	1700	123
	16	1.5	226	2300	166	—	—	—
8T	6	1.0	12	125	9	14	145	9
	8	1.25	29	300	22	32	330	24
	10	1.25	61	620	45	68	690	50
	12	1.25	108	1100	80	123	1250	90
	14	1.5	172	1750	127	196	2000	145
	16	1.5	265	2700	195	299	3050	221

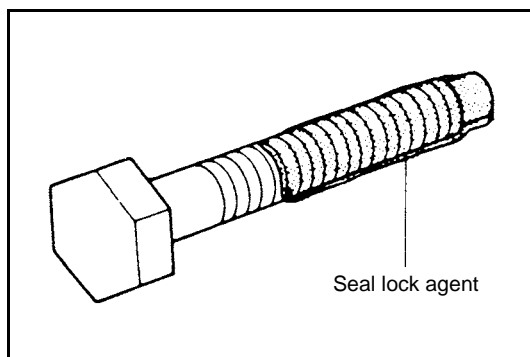

## PRECOAT BOLTS

(Bolts with seal lock agent coating on threads)

1. Do not use the precoat bolt as it is in either of the following cases:
  - (a) After it is removed.
  - (b) When the precoat bolt is moved (loosened or tightened) by tightness check, etc.

**Note:**

**For torque check, use the lower limit of the allowable tightening torque range. If the bolt moves, retighten it according to the steps below.**

2. Method for reuse of precoat bolts
  - (1) Wash the bolt and threaded hole. (The threaded hole must be washed even for replacement of the bolt.)
  - (2) Perfectly dry the washed parts by air blowing.
  - (3) Coat the specified seal lock agent to the threaded portion of the bolt.

## HIGH PRESSURE HOSE FITTING TIGHTENING TORQUE

1. When connecting a high pressure hose, wipe the hose fitting and mating nipple contact surfaces with clean cloth to remove foreign matters and dirt. Also check no dent or other damage on the contact surfaces before installation.
2. When connecting a high pressure hose, hold the hose to align the fitting with the nipple and tighten the fitting.
3. The maximum tightening torque must not exceed twice the standard tightening torque.

Nominal diameter of screw	Standard tightening torque N·m (kgf·cm) [ft·lbf]		Hose inside diameter mm (in)
	Standard	Tightening range	
7/16 — 20UNF	25 (250) [18.1]	24 ~ 26 (240 ~ 270) [17.4 ~ 19.5]	6 (0.24)
9/16 — 18UNF	49 (500) [36.2]	47 ~ 52 (480 ~ 530) [34.7 ~ 38.3]	9 (0.35)
3/4 — 16UNF	59 (600) [43.4]	56 ~ 62 (570 ~ 630) [41.2 ~ 45.6]	12 (0.47)
7/8 — 14UNF	59 (600) [43.4]	56 ~ 62 (570 ~ 630) [41.2 ~ 45.6]	12 (0.47), 15 (0.59)
1-1/16 — 12UNF	118 (1200) [86.8]	112 ~ 123 (1140 ~ 1250) [82.5 ~ 90.4]	19 (0.75)
1-5/16 — 12UNF	137 (1400) [101.3]	130 ~ 144 (1330 ~ 1470) [96.2 ~ 106.4]	25 (0.98)
PF1/4	25 (250) [18.1]	24 ~ 26 (240 ~ 270) [17.4 ~ 19.5]	6 (0.24)
PF3/8	49 (500) [36.2]	47 ~ 52 (480 ~ 530) [34.7 ~ 38.3]	9 (0.35)
PF1/2	59 (600) [43.4]	56 ~ 62 (570 ~ 630) [41.2 ~ 45.6]	12 (0.47)
PF3/4	118 (1200) [86.8]	112 ~ 123 (1140 ~ 1250) [82.5 ~ 90.4]	19 (0.75)
PF1	137 (1400) [101.3]	130 ~ 144 (1330 ~ 1470) [96.2 ~ 106.4]	25 (0.98)

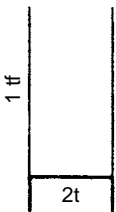
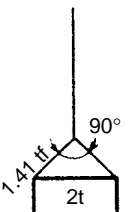
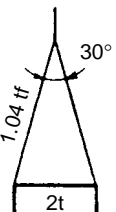
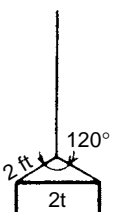
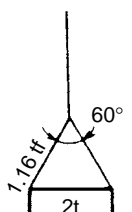

## WIRE ROPE SUSPENSION ANGLE LIST

Lifting angle	Tension	Compression	Suspension method	Lifting angle	Tension	Compression	Suspension method
0°	1.00 time	0 time		90°	1.41 time	1.00 time	
30°	1.04 time	0.27 time		120°	2.00 time	1.73 time	
60°	1.16 time	0.58 time					

## SAFE LOAD FOR EACH WIRE ROPE SUSPENSION ANGLE

Unit: N (tf) [lbf]

Rope diameter	Cutting load	Single-rope suspension	Two-rope suspension					Four-rope suspension			
		0°	0°	30°	60°	90°	0°	30°	60°	90°	
6 mm (0.24 in)	21380 (2.18) [4807]	3040 (0.31) [683.6]	6080 (0.62) [1367]	5880 (0.6) [1323]	5200 (0.53) [1169]	4310 (0.44) [970]	12160 (1.24) [2734]	11770 (1.2) [2646]	10400 (1.06) [2337]	8630 (0.88) [1940]	
8 mm (0.32 in)	31480 (3.21) [7078]	4410 (0.45) [992.3]	8830 (0.9) [1985]	8530 (0.87) [1918]	7650 (0.78) [1720]	6280 (0.64) [1411]	17650 (1.8) [3969]	17060 (1.74) [3937]	15300 (1.56) [3440]	12550 (1.28) [2822]	
10 mm (0.4 in)	49230 (5.02) [11.69]	6960 (0.71) [1565.6]	14020 (1.43) [3153]	13440 (1.37) [3021]	11770 (1.2) [2646]	9810 (1.0) [2205]	27460 (2.8) [6174]	26480 (2.7) [5954]	23540 (2.4) [5292]	19610 (2.0) [4410]	
12.5 mm (0.5 in)	76880 (7.84) [17387]	10980 (1.12) [2469.5]	21570 (2.2) [4851]	21280 (2.1) [4631]	18630 (1.9) [4190]	14710 (1.5) [3308]	43150 (4.4) [9702]	41190 (4.2) [9261]	37270 (3.8) [8379]	29420 (3.0) [6615]	
14 mm (0.56 in)	96400 (9.83) [21675]	13730 (1.4) [3087]	27460 (2.8) [6174]	26480 (2.7) [5954]	23540 (2.4) [5292]	18630 (1.9) [4190]	54920 (5.6) [12348]	52960 (5.4) [11907]	47070 (4.8) [10584]	37270 (3.8) [8379]	

## COMPONENTS WEIGHT

Member	Model	Weight kg (lbs)
Battery ASSY	See page 1-2.	
Drive motor ASSY	15-18	Approx. 90 (198)
	20 ~ 32	Approx. 120 (265)
	35 ~ 55	Approx. 190 (419)
Pump motor ASSY	15-18	Approx. 40 (88)
	20 ~ 32	Approx. 65 (143)
	35 ~ 55	Approx. 65 (143)
Counterweight	15	Approx. 565 (1246)
	18	Approx. 695 (1532)
	20	Approx. 670 (1477)
	25	Approx. 1065 (2348)
	30	Approx. 1195 (2635)
	32	Approx. 1370 (3021)
	35	Approx. 1420 (3131)
	45	Approx. 2240 (4939)
V mast ASSY L/fork and backrest (with lift cylinder, max. lifting height: 3300 (130 in))	15-18	Approx. 440 (970)
	20-25	Approx. 510 (1120)
	30-32	Approx. 630 (1390)
V mast ASSY L/fork and backrest (with lift cylinder, max. lifting height: 3000 (118 in))	35	Approx. 890 (1960)
	45	Approx. 950 (2090)
	55	Approx. 1270 (2800)

## RECOMMENDED LUBRICANT QUANTITY & TYPES

Description	Application	Quantity l (US gal)	Classification	Type
Drive unit	15-18 model	3.8 (1.00)	API GL-4	Hypoid gear oil SAE75W-80W
	15-18 (dead-man spec.) model 20 ~ 32 model	5.5 (1.45)		
	35 ~ 55 model	2.0 (0.53)		
Differential	35 ~ 55 model	4.5 (1.18)		
Planetary gear	35 ~ 55 model	Proper quantity		
Hydraulic oil (V·FV·FSV mast: lifting height 3300 mm (130 in))	15-18 model	17.0 (4.49)	ISO VG32	Hydraulic oil
	20 ~ 32 model	22.0 (5.81)		
Hydraulic oil (V·FV·FSV mast: lifting height 3000 mm (118 in))	35 ~ 55 model	34.5 (9.11)		
Brake line	15 ~ 32 model	Proper quantity	—	SAE J-1703 DOT-3
Chassis parts	All model	Proper quantity	—	<ul style="list-style-type: none"> <li>• MP grease</li> <li>• Molybdenum disulfide grease</li> </ul>
Battery	All model	Proper quantity	—	Distilled water

# LUBRICATION CHART

15 ~ 32 Model

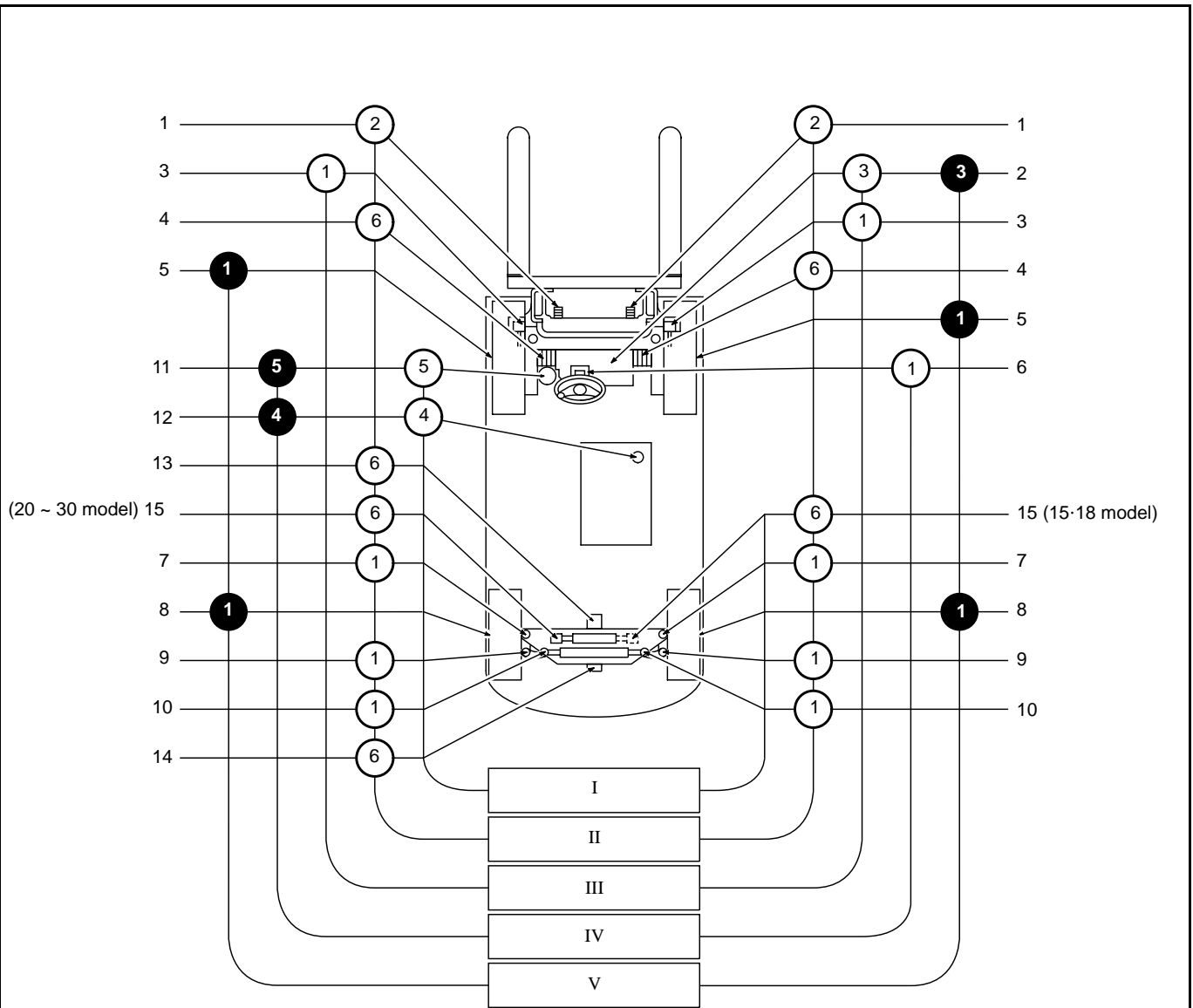

- Inspection
- Replacement
- ① MP Grease
- ② Engine Oil
- ③ Hypoid gear Oil
- ④ Hydraulic Oil
- ⑤ Brake Fluid
- ⑥ Molybdenum disulfide greass

- I. Inspect every 8 hours (daily)
- II. Inspect every 40 hours (weekly)
- III. Inspect every 170 hours (monthly)
- IV. Inspect every 1000 hours (6 monthly)
- V. Inspect every 2000 hours (annual)

- 1 Chain
- 2 Drive unit
- 3 Tilt cylinder front pin
- 4 Mast support bush
- 5 Front wheel bearing
- 6 Tilt steering lock mechanism
- 7 Steering knuckle king pin
- 8 Rear wheel bearing
- 9 Tie rod end pin
- 10 Rear axle cylinder end pin
- 11 Brake master cylinder
- 12 Oil tank
- 13 Rear axle beam front pin
- 14 Rear axle beam rear pin
- 15 Swing lock cylinder crank and rod pin