

TOYOTA COROLLA FR REPAIR MANUAL FOR CHASSIS & BODY

INTRODUCTION	I
CLUTCH	C
MANUAL TRANSMISSION	M
AUTOMATIC TRANSMISSION	A
PROPELLER SHAFT	P
FRONT AXLE AND SUSPENSION	F
REAR AXLE AND SUSPENSION	R
BRAKE SYSTEM	B
STEERING	S
BODY ELECTRICAL SYSTEM	B
BODY	B
AIR CONDITIONING SYSTEM	A
SERVICE SPECIFICATIONS	A
STANDARD BOLT TIGHTENING TORQUE	B
SI METRIC CONVERSION TABLE	C
SST	D
ELECTRICAL WIRING DIAGRAMS	E

VEHICLE LIFT AND SUPPORT LOCATIONS

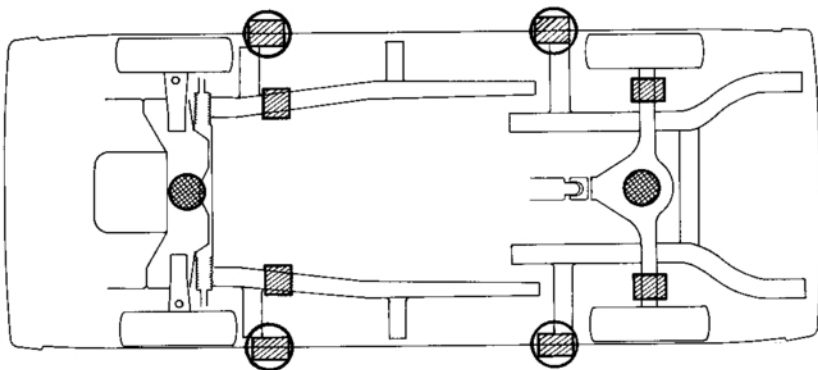

Front ←

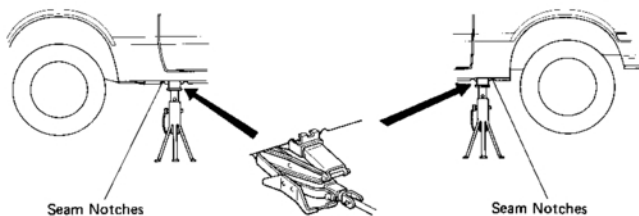

JACK POSITION

Front Center of front suspension crossmember
 Rear Center of rear axle housing

PANTOGRAPH JACK POSITION SUPPORT POSITION

Safety stand 

CLUTCH

	Page
TROUBLESHOOTING	CL-2
CHECK AND ADJUSTMENT OF CLUTCH PEDAL	CL-3
BLEEDING OF CLUTCH SYSTEM	CL-3
CLUTCH MASTER CYLINDER	CL-4
CLUTCH RELEASE CYLINDER	CL-6
CLUTCH UNIT	CL-7



TROUBLESHOOTING

Problem	Possible cause	Remedy	Page
Hard to shift or will not shift	Clutch pedal freeplay excessive	Adjust pedal freeplay	CL-3
	Clutch release cylinder faulty	Repair release cylinder	CL-6
	Clutch master cylinder faulty	Repair master cylinder	CL-4
	Clutch disc out of true, lining greasy or broken	Inspect clutch disc	CL-8
	Splines on input shaft or clutch disc dirty or burred	Repair as necessary	CL-7
	Clutch pressure plate faulty	Replace clutch cover	CL-9
Transmission jumps out of gear	Clutch pilot bearing worn	Replace pilot bearing	CL-9
Clutch slips	Clutch pedal freeplay insufficient	Adjust pedal freeplay	CL-3
	Clutch disc lining oily or worn out	Inspect clutch disc	CL-8
	Pressure plate faulty	Replace clutch cover	CL-9
	Release fork binds	Inspect release fork	CL-7
Clutch grabs/chatters	Clutch disc lining oily or worn out	Inspect clutch disc	CL-8
	Pressure plate faulty	Replace clutch cover	CL-9
	Clutch diaphragm spring bending	Align clutch diaphragm	CL-11
	Engine mounts loose	Repair as necessary	
Clutch pedal spongy	Air in clutch lines	Bleed clutch system	CL-3
	Clutch release cylinder faulty	Repair release cylinder	CL-6
	Clutch master cylinder faulty	Repair master cylinder	CL-4
Clutch noisy	Loose part inside housing	Repair as necessary	
	Release bearing worn or dirty	Replace release bearing	CL-10
	Pilot bearing worn	Replace pilot bearing	CL-9
	Release fork or linkage sticks	Repair as necessary	

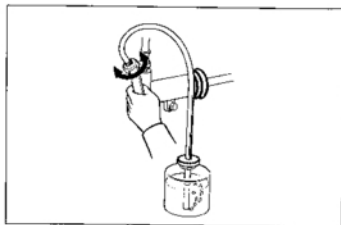
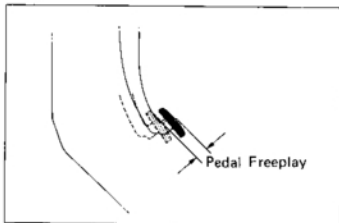
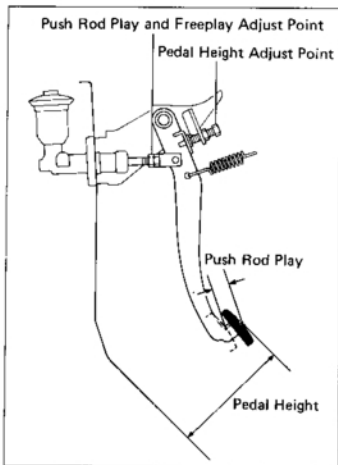

CHECK AND ADJUSTMENT OF CLUTCH PEDAL

1. CHECK THAT PEDAL HEIGHT IS CORRECT

Pedal height from asphalt sheet:

- LHD 161 – 171 mm (6.34 – 6.73 in.)
 RHD 162 – 172 mm (6.38 – 6.77 in.)

2. IF NECESSARY, ADJUST PEDAL HEIGHT

- Remove the instrument lower finish panel and air duct.
- Loosen the lock nut and turn the stopper bolt until the height is correct. Tighten the lock nut.

3. CHECK THAT PEDAL FREEPLAY AND PUSH ROD PLAY ARE CORRECT

(Pedal Freeplay)

Push in on the pedal until the beginning of clutch resistance is felt.

Pedal freeplay: 13 – 23 mm (0.51 – 0.91 in.)

Push rod play at pedal top:

1.0 – 5.0 mm (0.039 – 0.197 in.)

4. IF NECESSARY, ADJUST PEDAL FREEPLAY AND PUSH ROD PLAY

- Loosen the lock nut and turn the push rod until the freeplay and push rod play are correct.
- Tighten the lock nut.
- After adjusting the pedal freeplay, check the pedal height.
- Install the air duct and instrument lower finish panel.

BLEEDING OF CLUTCH SYSTEM

NOTE: If any work is done on the clutch system or if air is suspected in the clutch lines, bleed the system of air.

CAUTION: DO NOT let brake fluid remain on a painted surface. Wash it off immediately.

1. FILL CLUTCH RESERVOIR WITH BRAKE FLUID

Check the reservoir frequently. Add fluid if necessary.

2. CONNECT VINYL TUBE TO BLEEDER PLUG

Insert the other end of the tube in a half-full container of brake fluid.

3. BLEED CLUTCH LINE

- Slowly pump the clutch pedal several times.
- While depressing the pedal, loosen the bleeder plug until the fluid starts to run out. Then close the bleeder plug.
- Repeat this procedure until there are no more air bubbles in the fluid.

CLUTCH MASTER CYLINDER COMPONENTS

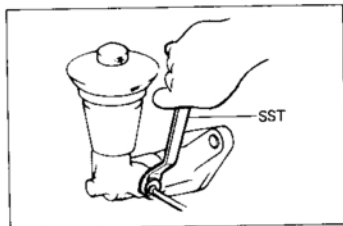
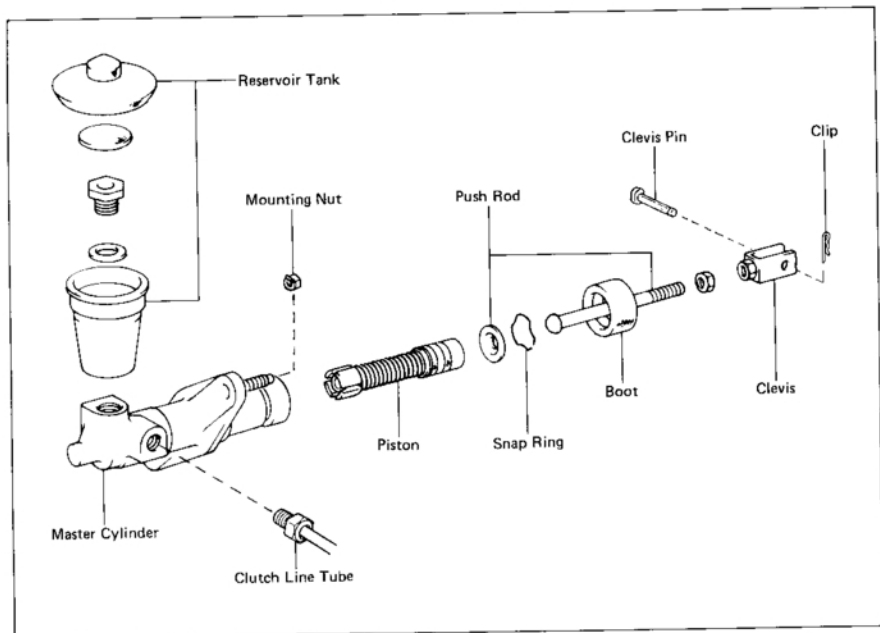

REMOVAL OF MASTER CYLINDER

1. DRAW OUT FLUID WITH SYRINGE
2. DISCONNECT CLUTCH LINE TUBE
Using SST, disconnect the tube.
SST 09751-36011
3. REMOVE INSTRUMENT LOWER FINISH PANEL AND AIR DUCT
4. REMOVE PEDAL RETURN SPRING
5. REMOVE CLEVIS PIN
Remove the clip and clevis pin.
6. REMOVE MOUNTING NUTS AND PULL OUT MASTER CYLINDER

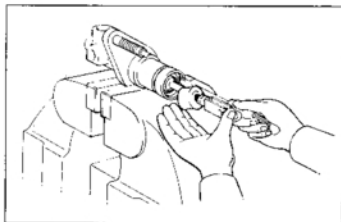
**DISASSEMBLY OF MASTER CYLINDER**

(See page CL-4)

1. REMOVE RESERVOIR TANK
2. REMOVE PUSH ROD
 - (a) Pull back the boot and, using a screwdriver, remove the snap ring.
 - (b) Pull out the push rod.
3. REMOVE PISTON

Using compressed air, remove the piston from the cylinder.

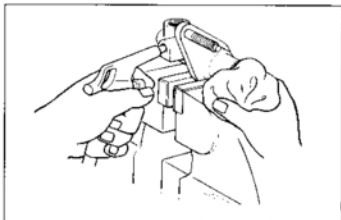
**ASSEMBLY OF MASTER CYLINDER**

(See page CL-4)

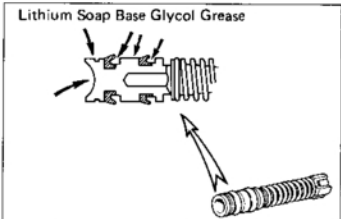

1. COAT PARTS WITH LITHIUM SOAP BASE GLYCOL GREASE, AS SHOWN
2. INSERT PISTON INTO CYLINDER
3. INSTALL PUSH ROD ASSEMBLY WITH SNAP RING
4. INSTALL RESERVOIR TANK

INSTALLATION OF MASTER CYLINDER

(See page CL-4)

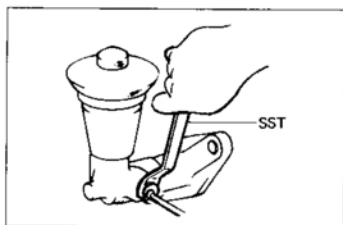

1. INSTALL MASTER CYLINDER WITH MOUNTING NUTS
2. CONNECT CLUTCH LINE TUBE

Using SST, connect the tube.
SST 09751-36011
3. CONNECT CLEVIS, AND INSTALL CLEVIS PIN AND CLIP

Secure the clevis pin with the clip.
4. INSTALL PEDAL RETURN SPRING
5. FILL CLUTCH RESERVOIR WITH BRAKE FLUID AND BLEED CLUTCH SYSTEM (See page CL-3)
6. CHECK FOR LEAKS
7. CHECK AND ADJUST CLUTCH PEDAL (See page CL-3)
8. INSTALL INSTRUMENT LOWER FINISH PANEL AND AIR DUCT

CLUTCH RELEASE CYLINDER COMPONENTS

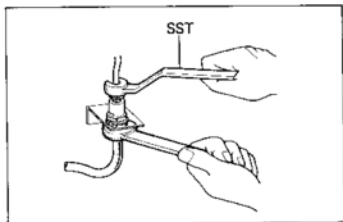
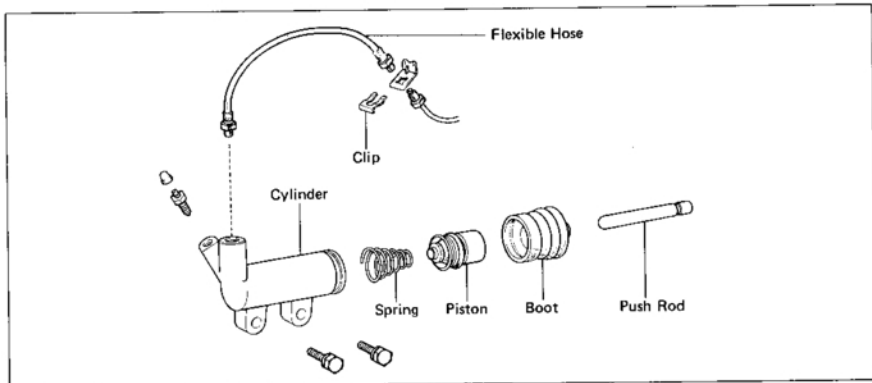

REMOVAL OF RELEASE CYLINDER

1. DISCONNECT FLEXIBLE HOSE

Using SST, disconnect the union.
SST 09751-36011

2. REMOVE TWO BOLTS AND PULL OUT RELEASE CYLINDER

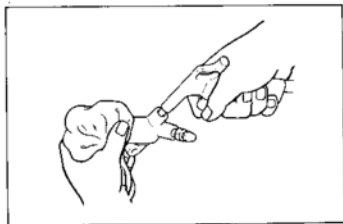

DISASSEMBLY OF RELEASE CYLINDER

1. PULL OUT PUSH ROD

2. REMOVE BOOT

3. REMOVE PISTON

Using compressed air, remove the piston and spring from the cylinder.

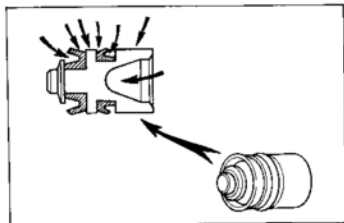

ASSEMBLY OF RELEASE CYLINDER

(See page CL-6)

1. COAT PISTON WITH LITHIUM SOAP BASE GLYCOL GREASE, AS SHOWN

2. INSERT SPRING AND PISTON INTO CYLINDER

3. INSTALL BOOT AND INSERT PUSH ROD

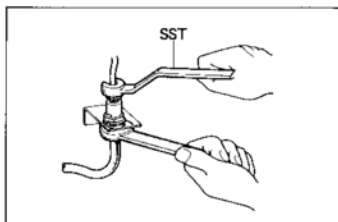
**INSTALLATION OF RELEASE CYLINDER**

(See page CL-6)

1. INSTALL RELEASE CYLINDER WITH TWO BOLTS**2. CAREFULLY CONNECT FLEXIBLE HOSE**

Using SST, connect the union.

SST 09751-36011

Torque: Union nut 155 kg-cm (11 ft-lb)

Flexible hose 235 kg-cm (17 ft-lb)

3. FILL CLUTCH RESERVOIR WITH BRAKE FLUID AND BLEED CLUTCH SYSTEM

(See page CL-3)

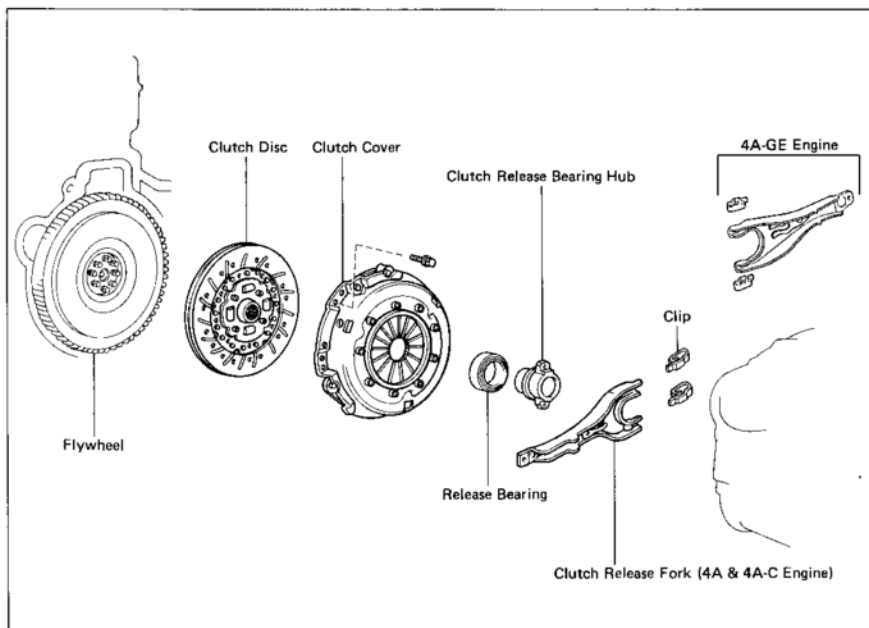
4. CHECK FOR LEAKS**CLUTCH UNIT
COMPONENTS**

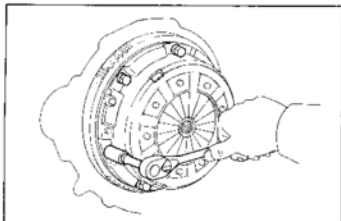

REMOVAL OF CLUTCH UNIT

(See page CL-7)

1. REMOVE TRANSMISSION (See page MT-3, 4)

NOTE: Do not drain the transmission oil.

2. REMOVE CLUTCH COVER AND DISC

- Loosen the set bolts one turn at a time until the spring tension is released.
- Remove the set bolts and pull off the clutch assembly.

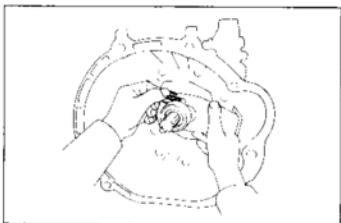

3. REMOVE BEARING, HUB AND FORK FROM TRANSMISSION

- Remove the retaining clip and pull off the bearing and hub.
- Remove the fork and boot.

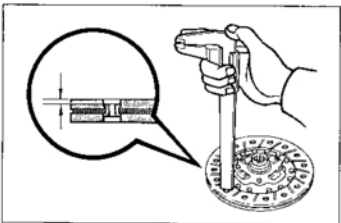

INSPECTION OF CLUTCH PARTS

1. INSPECT CLUTCH DISC FOR WEAR OR DAMAGE

Using calipers, measure the rivet head depth.

Minimum rivet depth: 0.3 mm (0.012 in.)

If a problem is found, replace the clutch disc.

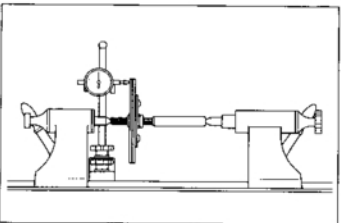

2. INSPECT CLUTCH DISC RUNOUT

Using a dial indicator, check the disc runout.

Maximum runout: 0.8 mm (0.031 in.)

If runout is excessive, replace the disc.

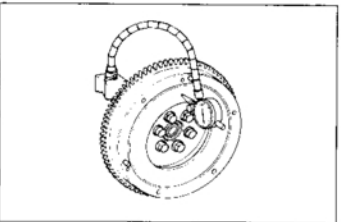

3. INSPECT FLYWHEEL RUNOUT

Using a dial indicator, check the flywheel runout.

Maximum runout: 0.2 mm (0.008 in.)

If runout is excessive, repair or replace the flywheel.

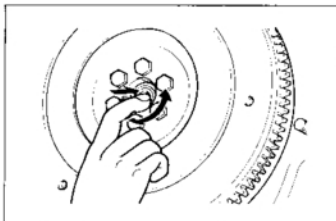

4. INSPECT PILOT BEARING

Turn the bearing by hand while applying force in the axial direction.

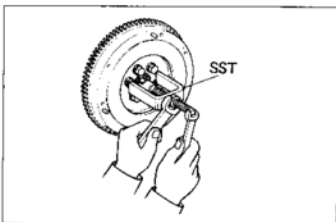

5. IF NECESSARY, REPLACE PILOT BEARING

(a) Using SST, remove the pilot bearing.

SST 09303-35011

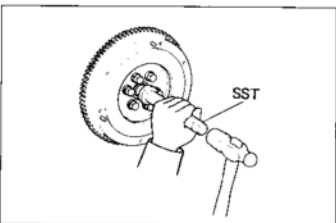

(b) Using SST, install the pilot bearing.

SST 09304-30012

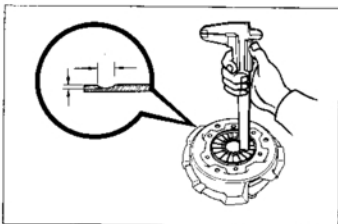

6. INSPECT DIAPHRAGM SPRING FOR WEAR

Using calipers, measure the diaphragm spring for depth and width of wear.

Limit: Depth 0.6 mm (0.024 in.)

Width 5.0 mm (0.197 in.)

If necessary, replace the clutch cover.

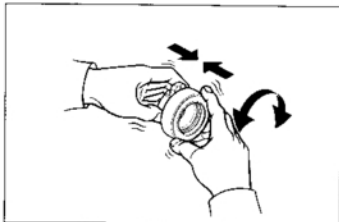

7. INSPECT RELEASE BEARING

Turn the bearing by hand while applying force in the axial direction.

NOTE: The bearing is permanently lubricated and requires no cleaning or lubrication.

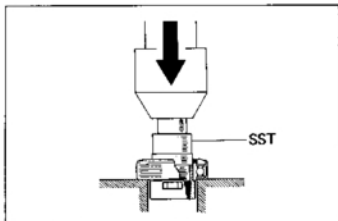

8. IF NECESSARY, REPLACE RELEASE BEARING

- (a) Using a press and SST, press the release bearing from the hub.

SST 09315-00010

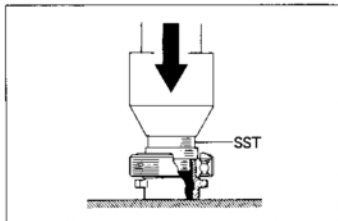

- (b) Using a press and SST, press a new release bearing into the hub.

SST 09315-00010

- (c) After installing the bearing, check that there is no drag on the bearing when it is turned under pressure.

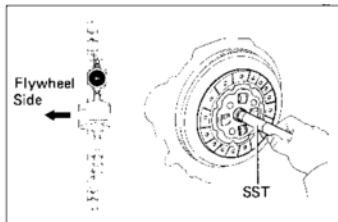

INSTALLATION OF CLUTCH UNIT

(See page CL-7)

1. INSTALL DISC ON FLYWHEEL

Using SST, install the disc on the flywheel.

SST 09301-36010

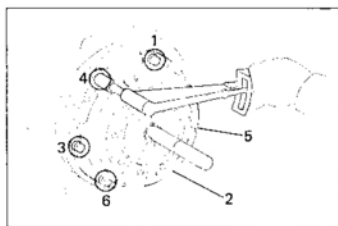

2. INSTALL CLUTCH COVER

Tighten the bolts evenly and gradually. Make several passes around the cover until it is snug. Torque the bolts.

Torque: 195 kg-cm (14 ft-lb)

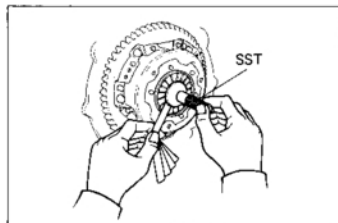

3. CHECK DIAPHRAGM SPRING TIP ALIGNMENT

Using a feeler gauge and SST, measure the gap between the spring tips and the tool.

SST 09301-00013

Maximum non-alignment: 0.5 mm (0.020 in.)

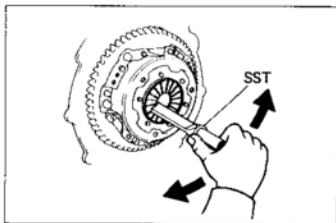

4. IF NECESSARY, ADJUST SPRINGS

Using SST, bend the springs until alignment is correct.
SST 09301-00013

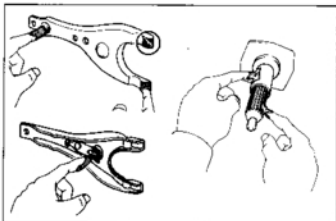

5. APPLY MOLYBDENUM DISULPHIDE LITHIUM BASE GREASE (NLGI NO. 2) OR MP GREASE

(a) Apply molybdenum disulphide lithium base grease to the following parts:

- Release fork and hub contact point
- Release fork and push rod contact point
- Release fork pivot point
- Clutch disc spline
- Release bearing hub inside groove

(b) Apply MP grease to the front of the release bearing.

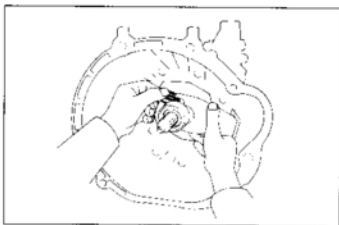
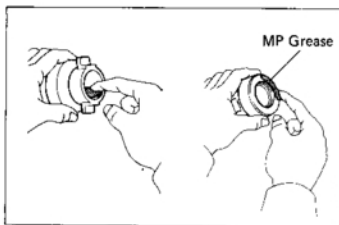

6. INSTALL BOOT, FORK, HUB AND BEARING ON TRANSMISSION

7. INSTALL TRANSMISSION (See pages MT-22, 23)

MANUAL TRANSMISSION

	Page
TROUBLESHOOTING	MT-2
T50 TRANSMISSION	MT-3
Removal of Transmission	MT-3
Components	MT-5
Disassembly of Transmission	MT-7
Inspection of Transmission Components	MT-10
Assembly of Transmission	MT-15
Installation of Transmission	MT-22

M

TROUBLESHOOTING

Problem	Possible cause	Remedy	Page
Hard to shift or will not shift	Splines on input shaft dirty or burred Transmission faulty	Repair as necessary Disassemble and inspect transmission	MT-3 MT-3
Transmission jumps out of gear	Transmission faulty	Disassemble and inspect transmission	MT-3

T50 TRANSMISSION**REMOVAL OF TRANSMISSION**

1. REMOVE NEGATIVE BATTERY TERMINAL WIRE
2. TURN DISTRIBUTOR
 - (a) Loosen the bolt.
 - (b) Turn the distributor so it does not strike against the dash panel.
3. REMOVE CONSOLE BOX
4. REMOVE SHIFT LEVER FROM INSIDE OF VEHICLE
5. RAISE VEHICLE AND DRAIN TRANSMISSION OIL
CAUTION: Be sure the vehicle is securely supported.

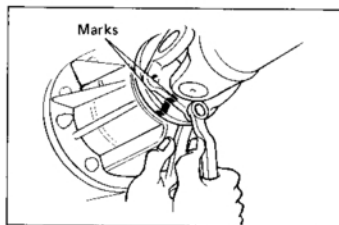
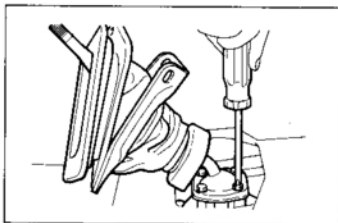

6. DISCONNECT PROPELLER SHAFT FLANGE FROM FLANGE ON DIFFERENTIAL
 - (a) Place matchmarks on the flanges.
 - (b) Remove the four bolts and nuts.

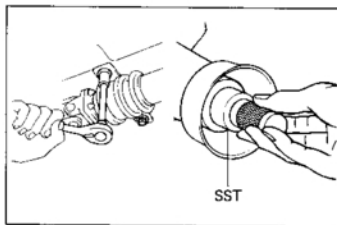

7. REMOVE CENTER SUPPORT BEARING FROM BODY (3-Joint Type)
8. REMOVE PROPELLER SHAFT
 - (a) Pull the yoke from the transmission.
 - (b) Insert SST in the transmission to prevent oil leakage. SST 09325-12010
9. REMOVE EXHAUST PIPE CLAMP BOLT

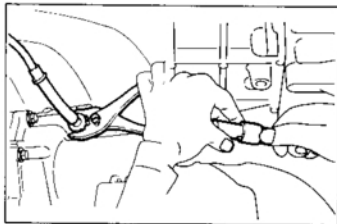

10. REMOVE SPEEDOMETER CABLE
11. DISCONNECT BACK-UP LIGHT SWITCH CONNECTOR

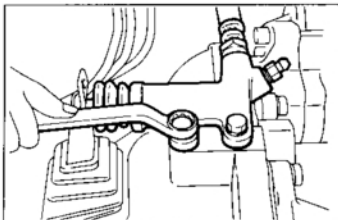
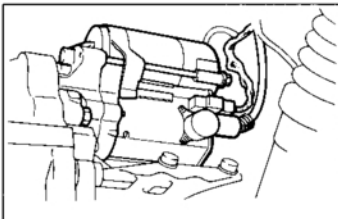
**12. REMOVE CLUTCH RELEASE CYLINDER****13. REMOVE STARTER**

- (a) Disconnect the two wires from the starter.
- (b) Remove the two bolts and the starter.

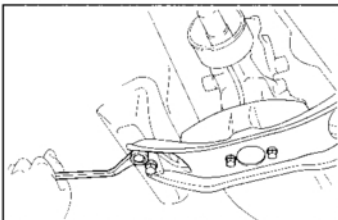
**14. JACK UP TRANSMISSION SLIGHTLY**

Raise the transmission enough to remove the weight from the rear support.

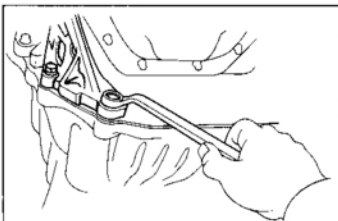
15. REMOVE ENGINE REAR MOUNTING**16. REMOVE STIFFENER PLATE AND TRANSMISSION BOLTS****17. REMOVE TRANSMISSION ASSEMBLY**

Pull out the transmission down and toward the rear.

COMPONENTS

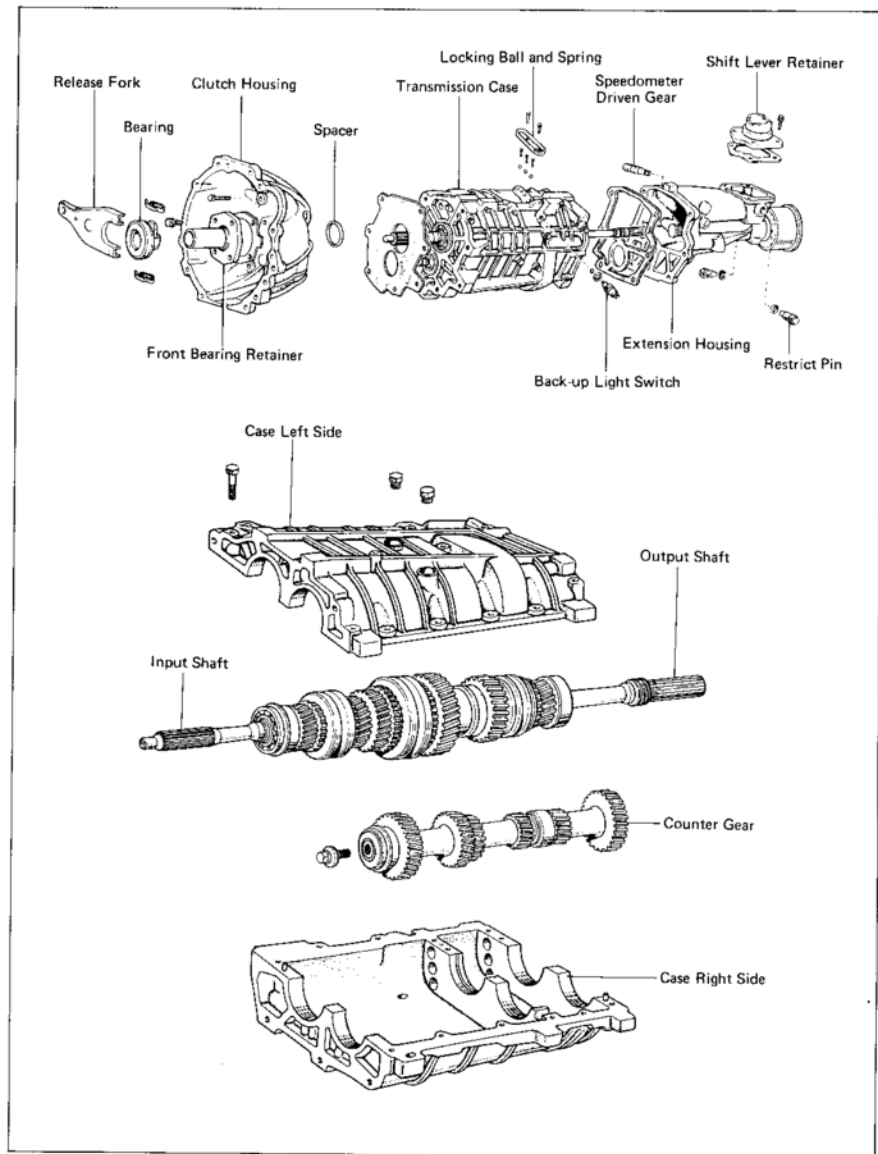

COMPONENTS (Cont'd)

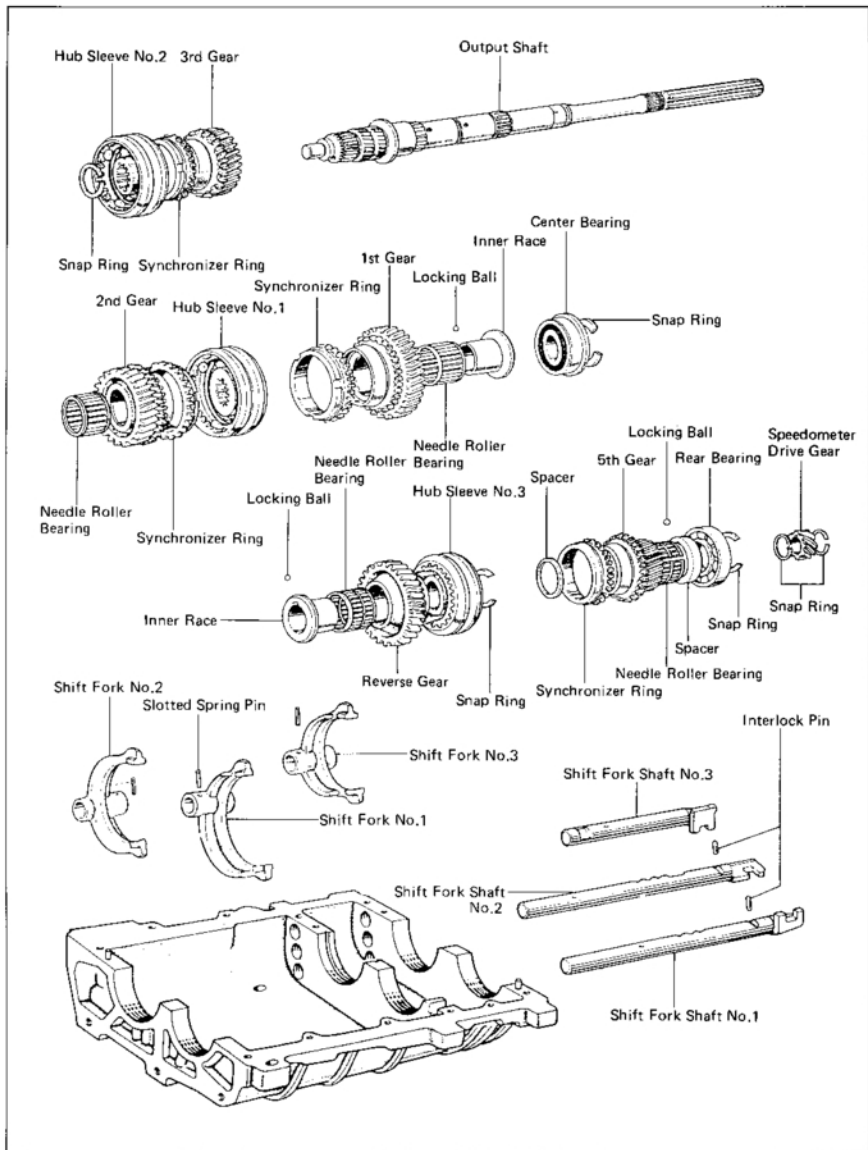

DISASSEMBLY OF TRANSMISSION

(See page MT-5, 6)

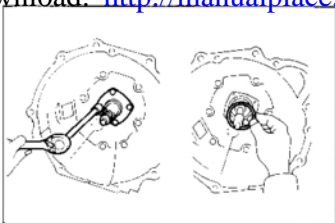

1. REMOVE BACK-UP LIGHT SWITCH, SPEEDOMETER DRIVEN GEAR, SHIFT LEVER RETAINER, RESTRICT PINS, CLUTCH RELEASE BEARING AND FORK

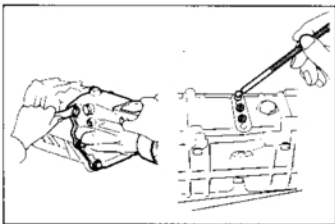

2. REMOVE CLUTCH HOUSING FROM TRANSMISSION CASE

- (a) Remove the front bearing retainer.
- (b) Remove the spacer.
- (c) Remove the clutch housing.

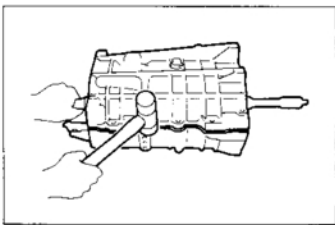

3. REMOVE EXTENSION HOUSING

Remove the six bolts and pull off the extension housing.

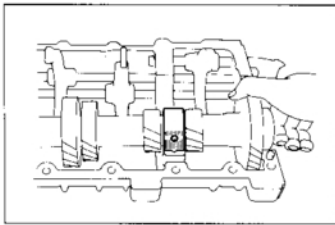

4. REMOVE LOCKING BALLS AND SPRINGS

- (a) Remove the case cover.
- (b) Using a magnetic finger, remove the three locking balls and springs.

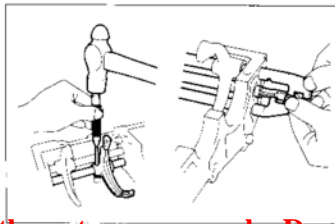

5. REMOVE LEFT CASE FROM RIGHT CASE

Separate the left case from the right case by tapping the projection with a plastic hammer.

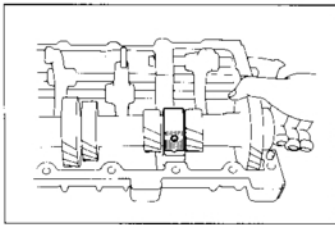

6. REMOVE INPUT AND OUTPUT SHAFT FROM RIGHT CASE

7. REMOVE COUNTER GEAR FROM RIGHT CASE

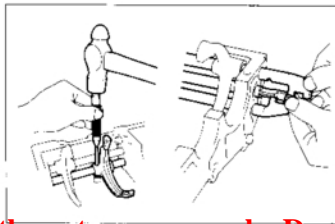

8. REMOVE SLOTTED SPRING PIN FROM SHIFT FORK AND FORK SHAFT

- (a) Using a punch and hammer, drive out the pin in the shift fork No. 1 through the hole in the case.
- (b) Drive out the pin in the shift fork No. 2 and No. 3.
- (c) Pull out the fork shaft No. 1, 2 and 3 by setting each to the neutral position.