

Last Modified: 8-1-2012	6.4 K	From: 201203
Model Year: 2013	Model: FR-S	Doc ID: RM000001PZR01CX
Title: AUDIO / VIDEO: AMPLIFIER ANTENNA: COMPONENTS (2013 FR-S)		

COMPONENTS

ILLUSTRATION

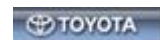
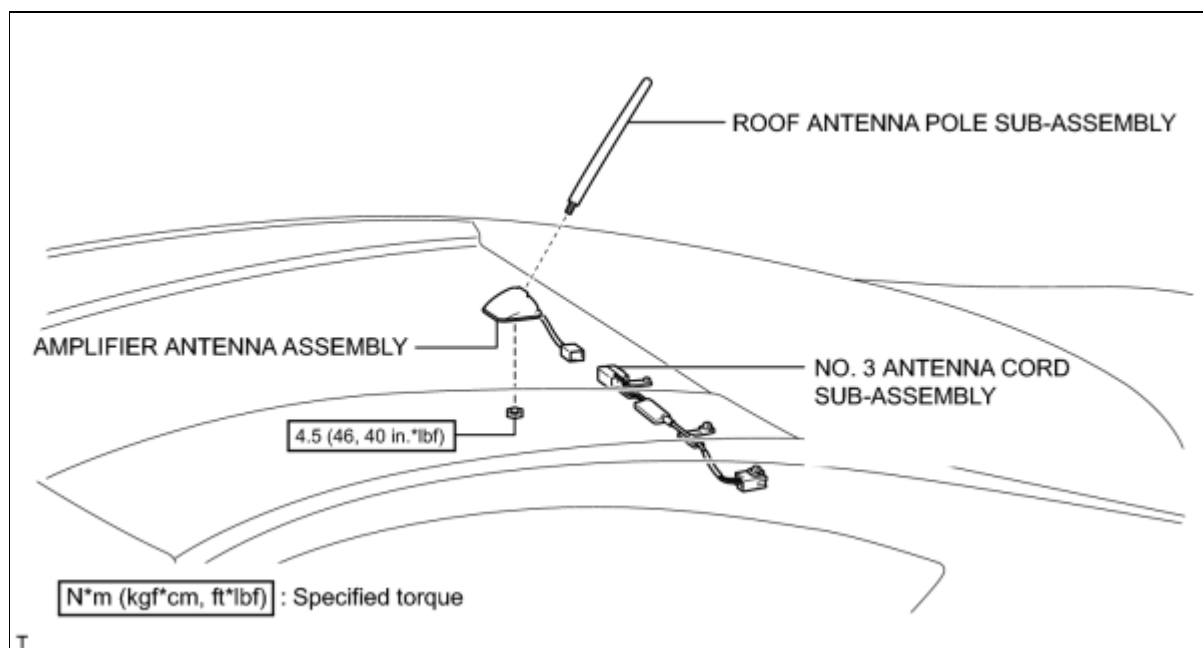

Last Modified: 8-1-2012	6.4 A	From: 201203
Model Year: 2013	Model: FR-S	Doc ID: RM000001PZQ01TX
Title: AUDIO / VIDEO: AMPLIFIER ANTENNA: INSTALLATION (2013 FR-S)		

INSTALLATION

1. INSTALL NO. 3 ANTENNA CORD SUB-ASSEMBLY

(a) Engage the 3 clamps and install the No. 3 antenna cord sub-assembly.

2. INSTALL AMPLIFIER ANTENNA ASSEMBLY

(a) Engage the 2 claws to install the amplifier antenna assembly.

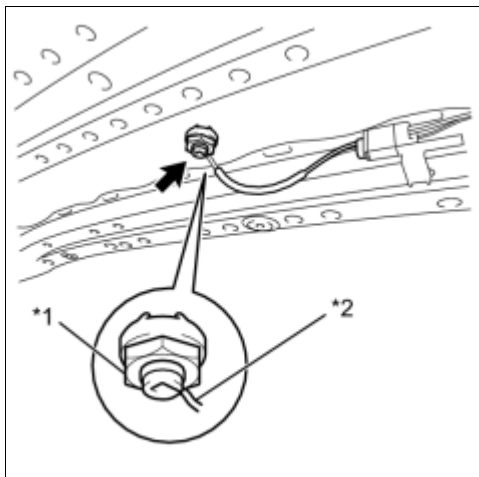

(b) Place the amplifier antenna cord in the amplifier antenna cutout.

(c) Install the amplifier antenna assembly with the nut.

Torque: 4.5 N·m (46 kgf·cm, 40in·lbf)

Text in Illustration

*1	Nut
*2	Amplifier Antenna Cord

3. INSTALL ROOF ANTENNA POLE SUB-ASSEMBLY [INFO](#)

4. INSTALL ROOF HEADLINING ASSEMBLY

[INFO](#)



Last Modified: 8-1-2012	6.4 A	From: 201203
Model Year: 2013	Model: FR-S	Doc ID: RM000001PZS01UX
Title: AUDIO / VIDEO: AMPLIFIER ANTENNA: REMOVAL (2013 FR-S)		

REMOVAL

1. REMOVE ROOF HEADLINING ASSEMBLY

INFO

2. REMOVE ROOF ANTENNA POLE SUB-ASSEMBLY

INFO

3. REMOVE AMPLIFIER ANTENNA ASSEMBLY

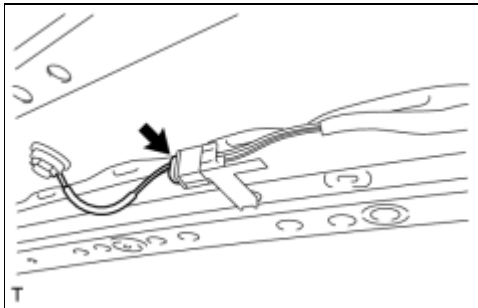

(a) Disconnect the connector.

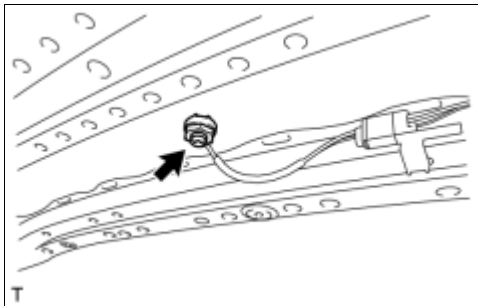

(b) Remove the nut.

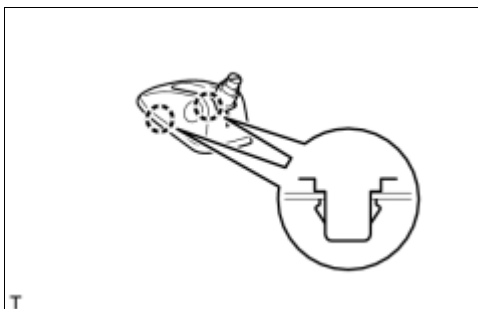

(c) Disengage the 2 claws and remove the amplifier antenna assembly.

4. REMOVE NO. 3 ANTENNA CORD SUB-ASSEMBLY

(a) Disengage the 3 clamps and remove the No. 3 antenna cord sub-assembly.

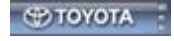
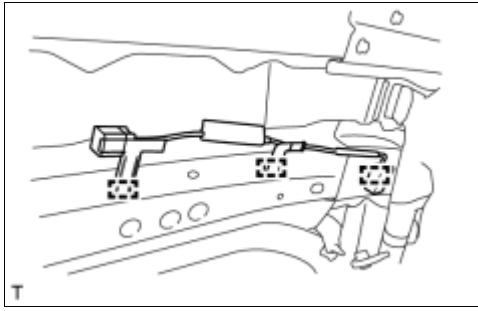

Last Modified: 8-1-2012	6.4 R	From: 201203
Model Year: 2013	Model: FR-S	Doc ID: RM0000012A606KX
Title: AUDIO / VIDEO: AUDIO AND VISUAL SYSTEM: PARTS LOCATION (2013 FR-S)		

PARTS LOCATION

ILLUSTRATION

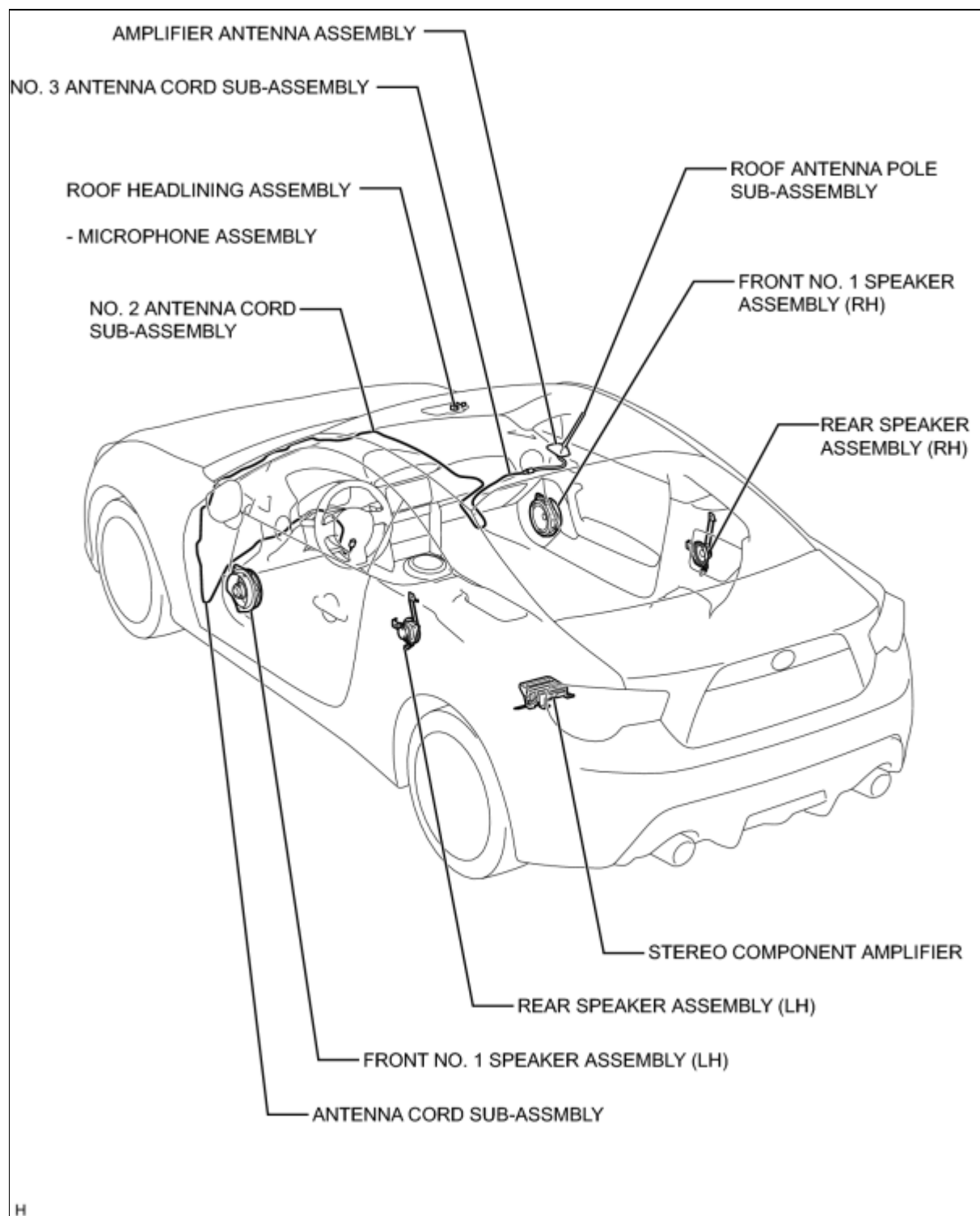

ILLUSTRATION

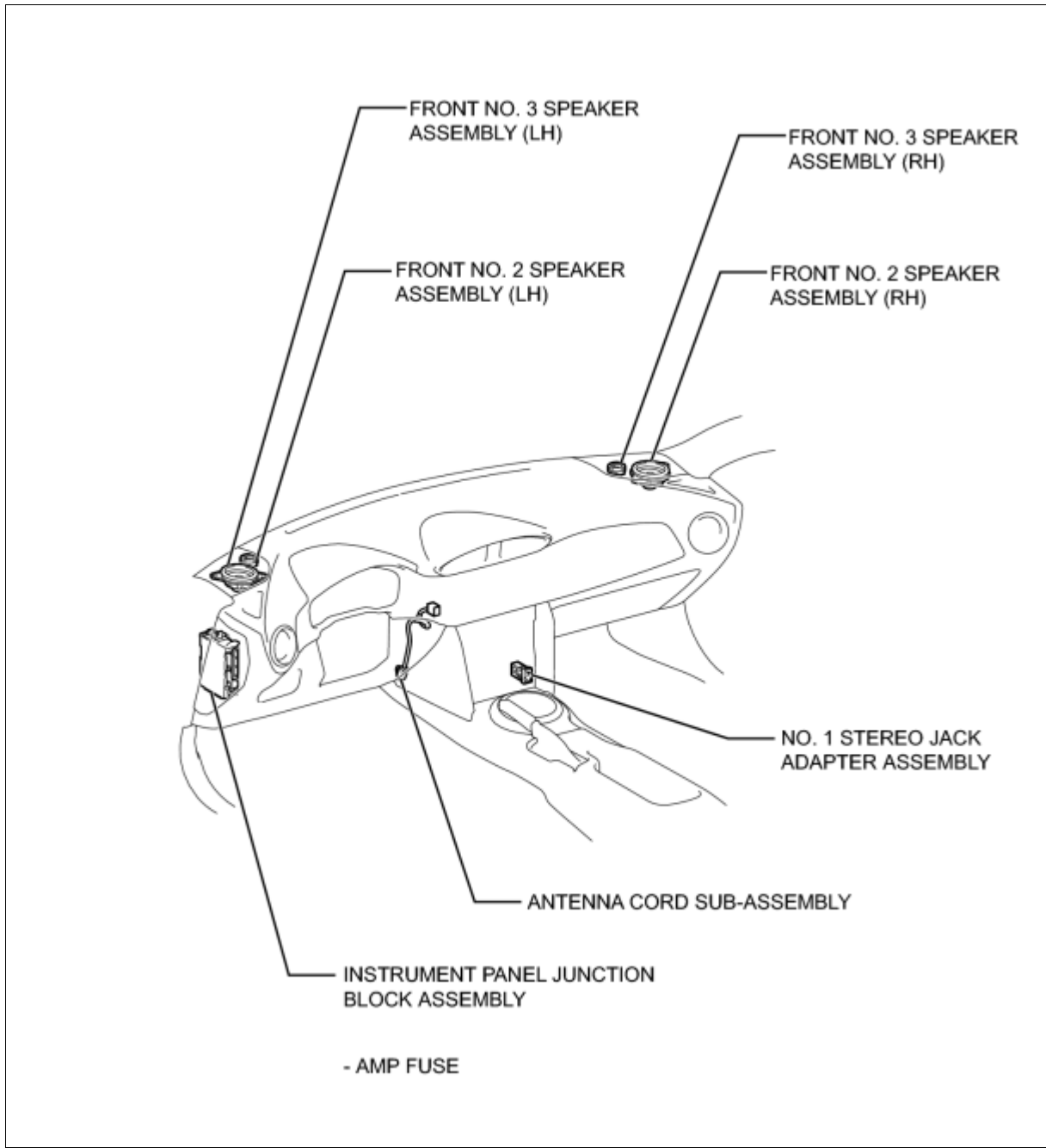

Last Modified: 8-1-2012	6.4 U	From: 201203
Model Year: 2013	Model: FR-S	Doc ID: RM0000012AB0ADX
Title: AUDIO / VIDEO: AUDIO AND VISUAL SYSTEM: SYSTEM DIAGRAM (2013 FR-S)		

SYSTEM DIAGRAM

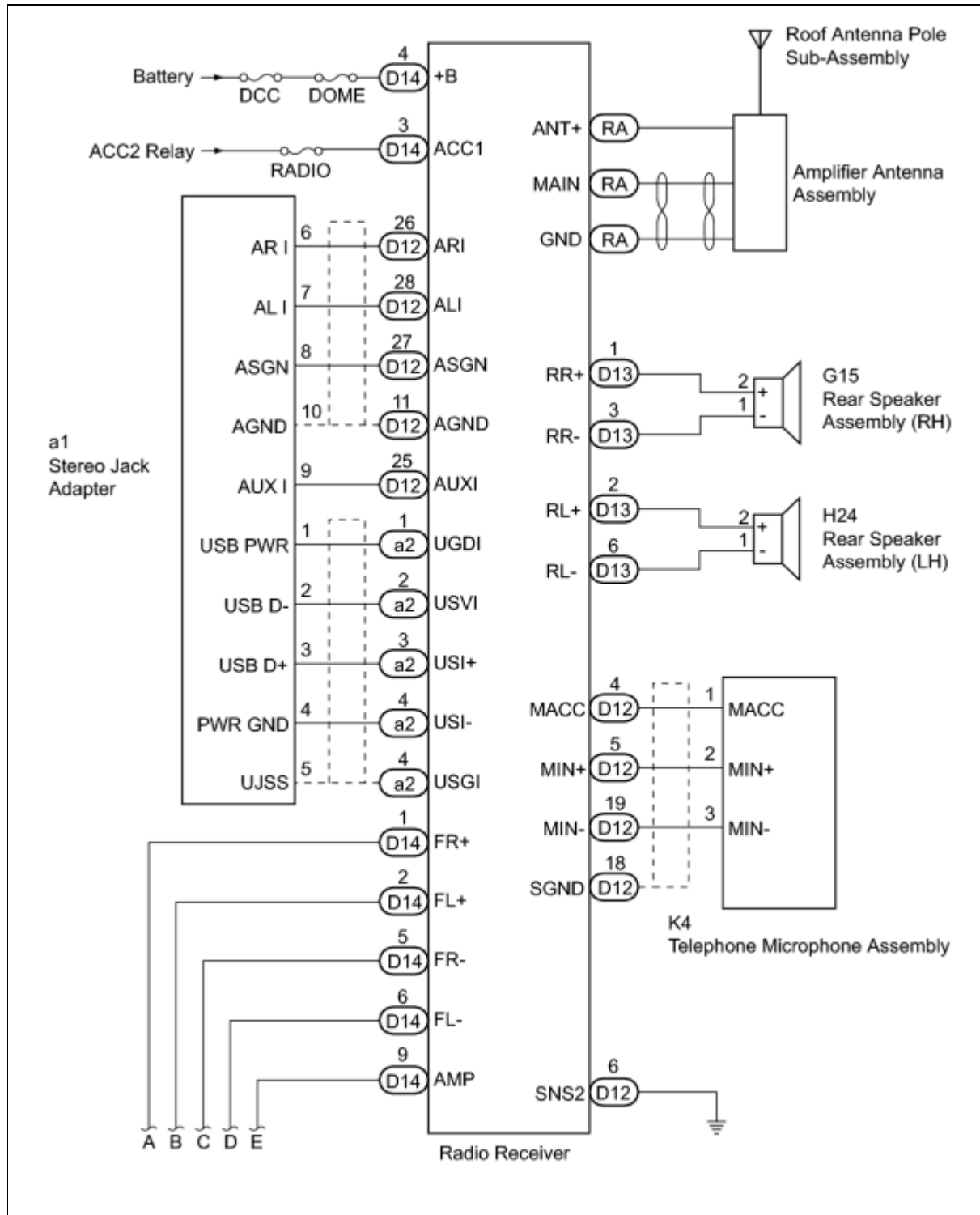

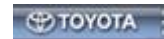
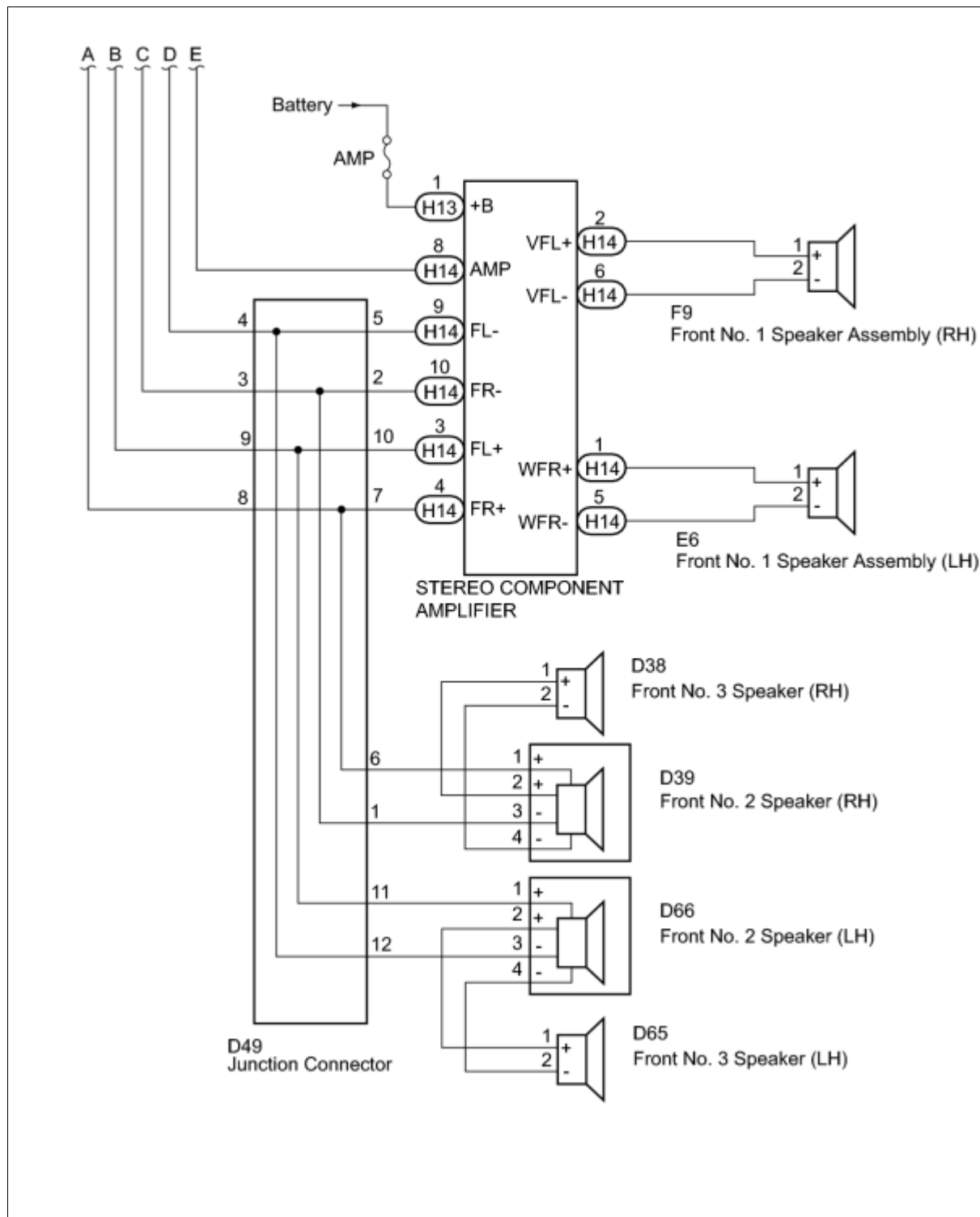

Last Modified: 8-1-2012	6.4 K	From: 201203
Model Year: 2013	Model: FR-S	Doc ID: RM000001PZ301FX
Title: AUDIO / VIDEO: FRONT DOOR SPEAKER: COMPONENTS (2013 FR-S)		

COMPONENTS

ILLUSTRATION

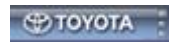
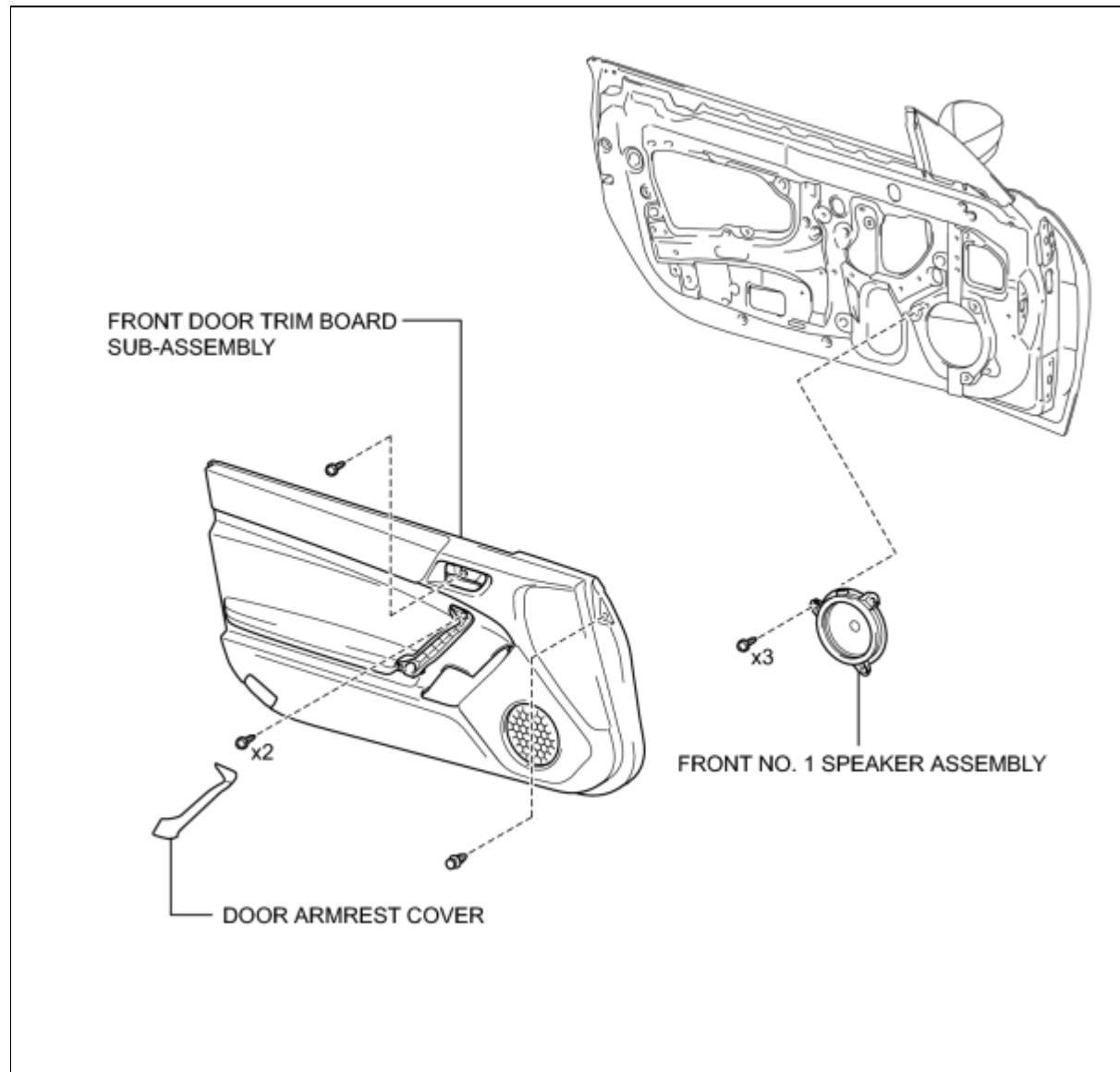

Last Modified: 8-1-2012	6.4 G	From: 201203
Model Year: 2013	Model: FR-S	Doc ID: RM0000020Q204DX
Title: AUDIO / VIDEO: FRONT DOOR SPEAKER: INSPECTION (2013 FR-S)		

INSPECTION

1. INSPECT FRONT NO. 1 SPEAKER ASSEMBLY

- (a) With the speaker installed, check that there is no looseness or other abnormalities.
- (b) Check that there is no foreign matter in the speaker, no tears on the speaker cone or other abnormalities.
- (c) Measure the resistance of the speaker.

Standard Resistance:

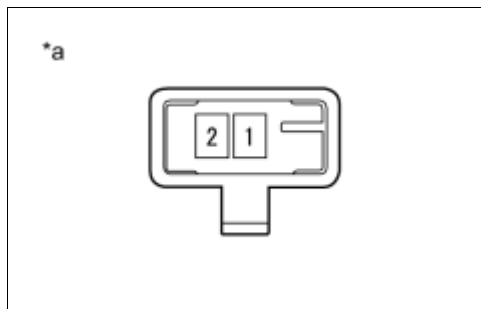

TESTER CONNECTION	CONDITION	SPECIFIED CONDITION
1 - 2	Always	2.6 to 3.2 Ω

If the result is not as specified, replace the speaker.

Text in Illustration

*a	Component without harness connected (Front No. 1 Speaker Assembly)
----	---

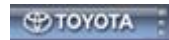

Last Modified: 8-1-2012	6.4 A	From: 201203
Model Year: 2013	Model: FR-S	Doc ID: RM000001PZ201QX
Title: AUDIO / VIDEO: FRONT DOOR SPEAKER: INSTALLATION (2013 FR-S)		

INSTALLATION

HINT:

Use the same procedure for the RH and LH sides.

1. INSTALL FRONT NO. 1 SPEAKER ASSEMBLY

- (a) Install the front No. 1 speaker assembly with the 3 screws.

NOTICE:

Do not touch the speaker cone.

- (b) Connect the connector.

2. INSTALL FRONT DOOR TRIM BOARD SUB-ASSEMBLY

3. INSTALL DOOR ARMREST COVER

4. INITIALIZE POWER WINDOW CONTROL SYSTEM



5. INSPECT POWER WINDOW OPERATION



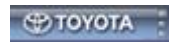

Last Modified: 8-1-2012	6.4 A	From: 201203
Model Year: 2013	Model: FR-S	Doc ID: RM000001PZ401QX
Title: AUDIO / VIDEO: FRONT DOOR SPEAKER: REMOVAL (2013 FR-S)		

REMOVAL

HINT:

Use the same procedure for the RH and LH sides.

1. REMOVE DOOR ARMREST COVER [INFO](#)
2. REMOVE FRONT DOOR TRIM BOARD SUB-ASSEMBLY [INFO](#)
3. REMOVE FRONT NO. 1 SPEAKER ASSEMBLY

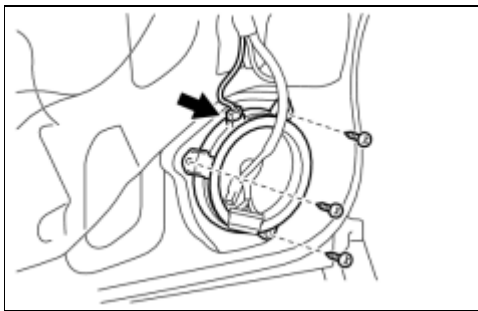

(a) Disconnect the connector.

(b) Remove the 3 screws and front No. 1 speaker assembly.

NOTICE:

Do not touch the speaker cone.



Last Modified: 8-1-2012	6.4 K	From: 201203
Model Year: 2013	Model: FR-S	Doc ID: RM000003AW400VX
Title: AUDIO / VIDEO: INSTRUMENT PANEL SPEAKER (for 6 Speakers): COMPONENTS (2013 FR-S)		

COMPONENTS

ILLUSTRATION

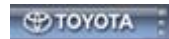
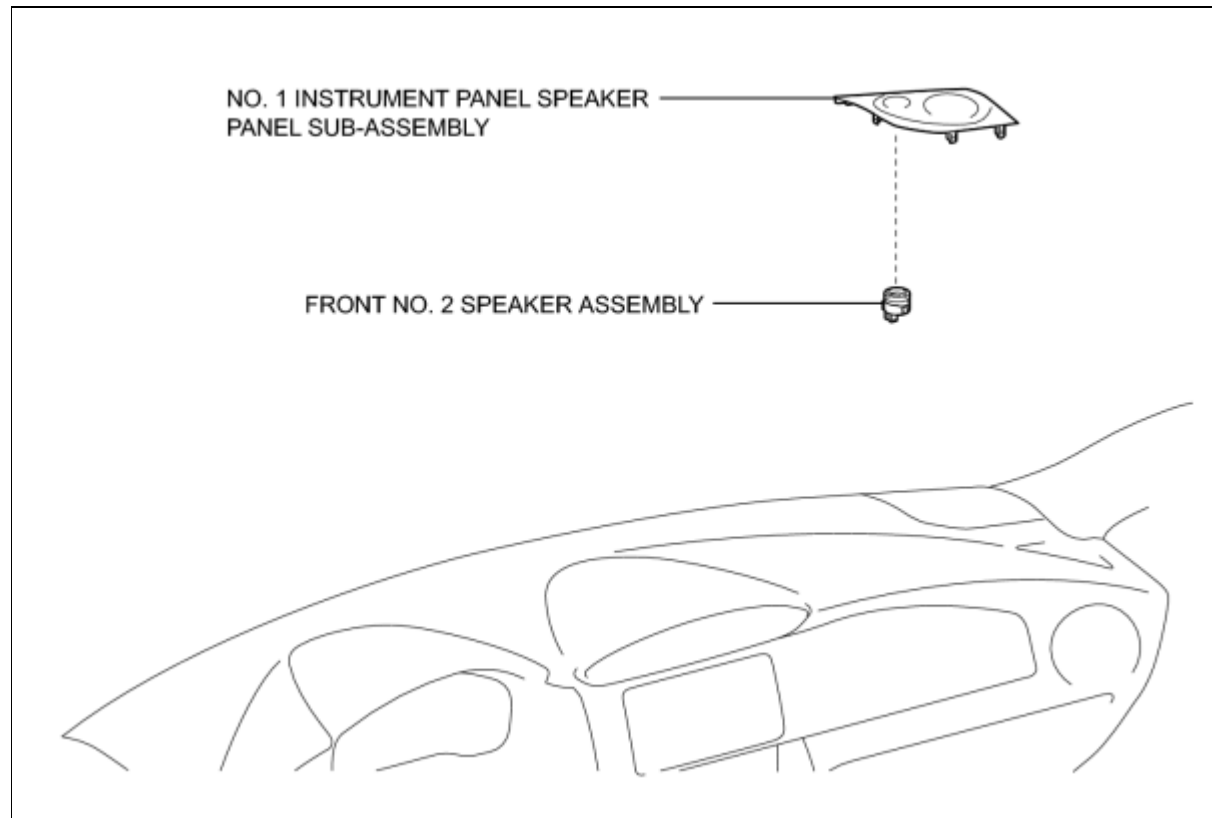

Last Modified: 8-1-2012	6.4 G	From: 201203
Model Year: 2013	Model: FR-S	Doc ID: RM000000VEM01UX
Title: AUDIO / VIDEO: INSTRUMENT PANEL SPEAKER (for 6 Speakers): INSPECTION (2013 FR-S)		

INSPECTION

1. INSPECT FRONT NO. 2 SPEAKER ASSEMBLY

(a) Check that there is no foreign matter in the front No. 2 speaker assembly, no tears on the front No. 4 speaker assembly cone or other abnormalities.

(b) Measure the resistance of the front No. 2 speaker assembly.

Standard Resistance:

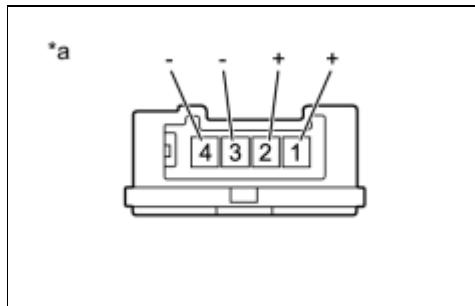

TESTER CONNECTION	CONDITION	SPECIFIED CONDITION
1 (+) - 2 (+)	Always	2.8 to 3.8 Ω
3 (-) - 4 (-)	Always	2.8 to 3.8 Ω

If the result is not as specified, replace the front No. 2 speaker assembly.

Text in Illustration

*a	Component without harness connected (Front No. 2 speaker assembly)
----	---



Last Modified: 8-1-2012	6.4 A	From: 201203
Model Year: 2013	Model: FR-S	Doc ID: RM000000VEL02GX
Title: AUDIO / VIDEO: INSTRUMENT PANEL SPEAKER (for 6 Speakers): INSTALLATION (2013 FR-S)		

INSTALLATION

HINT:

Use the same procedure for the RH and LH sides.

1. INSTALL FRONT NO. 2 SPEAKER ASSEMBLY

- (a) Engage the 3 claws to install the front No. 2 speaker assembly to the No. 1 instrument panel speaker panel sub-assembly.

NOTICE:

Do not touch the cone part of the speaker.

2. INSTALL NO. 1 INSTRUMENT PANEL SPEAKER PANEL SUB-ASSEMBLY

[INFO](#)

Last Modified: 8-1-2012	6.4 A	From: 201203
Model Year: 2013	Model: FR-S	Doc ID: RM000000VEO02CX
Title: AUDIO / VIDEO: INSTRUMENT PANEL SPEAKER (for 6 Speakers): REMOVAL (2013 FR-S)		

REMOVAL

HINT:

Use the same procedure for the RH and LH sides.

1. REMOVE NO. 1 INSTRUMENT PANEL SPEAKER PANEL SUB-ASSEMBLY INFO
2. REMOVE FRONT NO. 2 SPEAKER ASSEMBLY

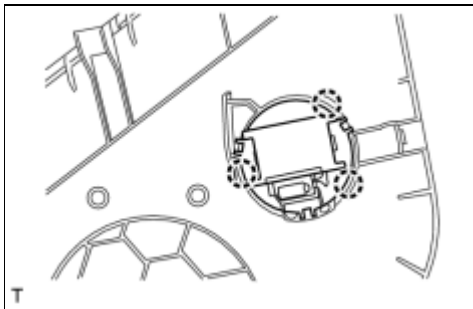

- (a) Disengage the 3 claws and remove the front No. 2 speaker assembly from the No. 1 instrument speaker panel sub-assembly.

NOTICE:

Do not touch the cone part of the speaker.



Last Modified: 8-1-2012	6.4 K	From: 201203
Model Year: 2013	Model: FR-S	Doc ID: RM000003AW400WX
Title: AUDIO / VIDEO: INSTRUMENT PANEL SPEAKER (for 8 Speakers): COMPONENTS (2013 FR-S)		

COMPONENTS

ILLUSTRATION

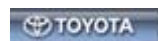
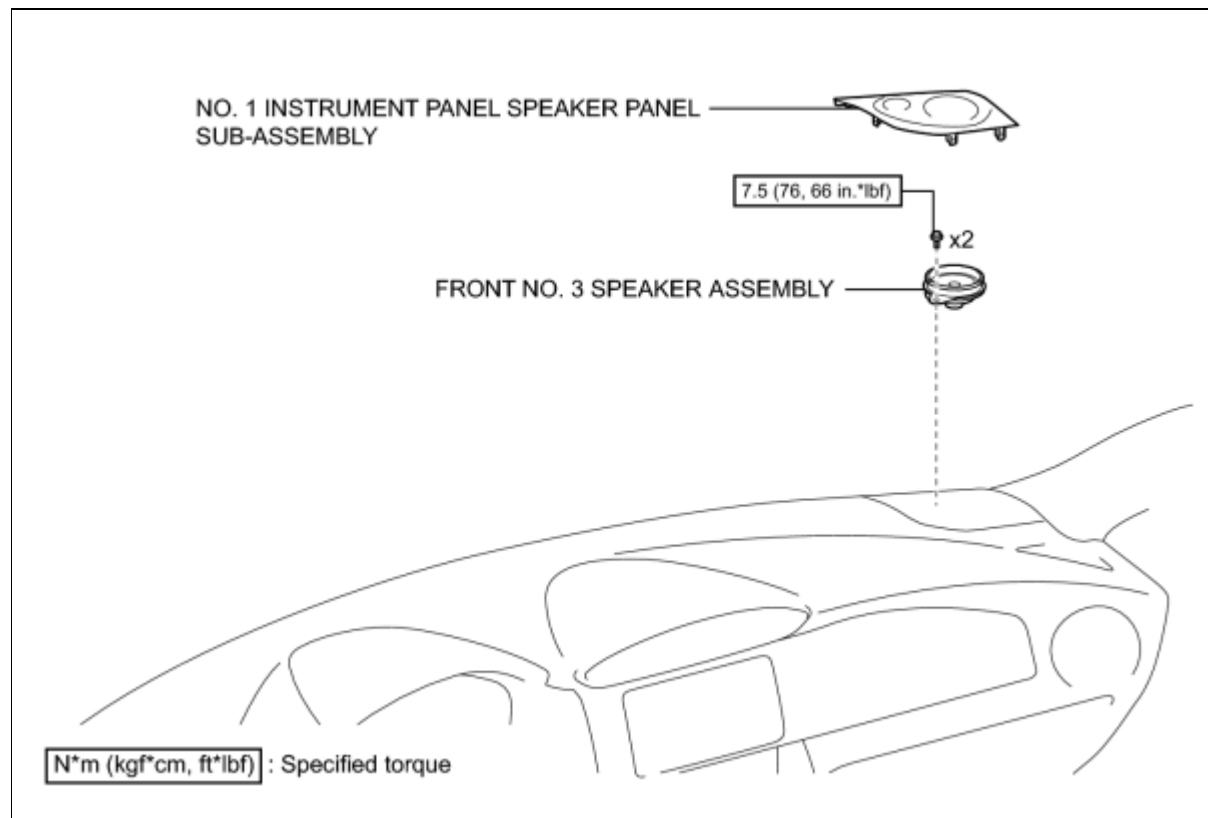

Last Modified: 8-1-2012	6.4 G	From: 201203
Model Year: 2013	Model: FR-S	Doc ID: RM000000VEM01VX
Title: AUDIO / VIDEO: INSTRUMENT PANEL SPEAKER (for 8 Speakers): INSPECTION (2013 FR-S)		

INSPECTION

1. INSPECT FRONT NO. 3 SPEAKER ASSEMBLY

(a) Check that there is no foreign matter in the front No. 3 speaker assembly, no tears on the front No. 3 speaker assembly cone or other abnormalities.

(b) Measure the resistance of the front No. 3 speaker assembly.

Standard Resistance:

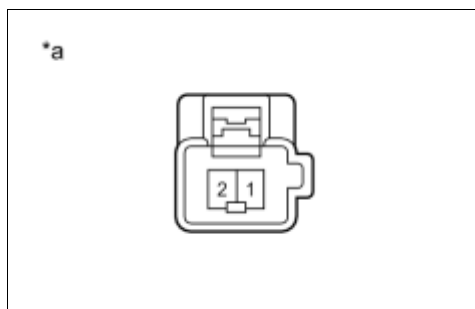

TESTER CONNECTION	CONDITION	SPECIFIED CONDITION
1 - 2	Always	3.7 to 4.7 Ω

If the result is not as specified, replace the front No. 3 speaker assembly.

Text in Illustration

*a	Component without harness connected (Front No. 3 speaker assembly)
----	---



Last Modified: 8-1-2012	6.4 A	From: 201203
Model Year: 2013	Model: FR-S	Doc ID: RM000000VEL02HX
Title: AUDIO / VIDEO: INSTRUMENT PANEL SPEAKER (for 8 Speakers): INSTALLATION (2013 FR-S)		

INSTALLATION

HINT:

Use the same procedure for the RH and LH sides.

1. INSTALL FRONT NO. 3 SPEAKER ASSEMBLY

- (a) Connect the connector.
- (b) Install the front No. 3 speaker assembly with the 2 bolts.

Torque: 7.5 N·m (76 kgf·cm, 66in·lbf)

NOTICE:

Do not touch the cone part of the speaker.

2. INSTALL NO. 1 INSTRUMENT PANEL SPEAKER PANEL SUB-ASSEMBLY

INFO



Last Modified: 8-1-2012	6.4 A	From: 201203
Model Year: 2013	Model: FR-S	Doc ID: RM000000VE002DX
Title: AUDIO / VIDEO: INSTRUMENT PANEL SPEAKER (for 8 Speakers): REMOVAL (2013 FR-S)		

REMOVAL

HINT:

Use the same procedure for the RH and LH sides.

1. REMOVE NO. 1 INSTRUMENT PANEL SPEAKER PANEL SUB-ASSEMBLY

[INFO](#)

2. REMOVE FRONT NO. 3 SPEAKER ASSEMBLY

(a) Disconnect the connector.

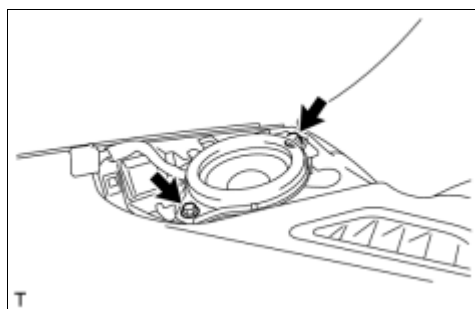

(b) Remove the 2 bolts and the front No. 3 speaker assembly.

NOTICE:

Do not touch the cone part of the speaker.

