

BACKHOE LOADER WORKSHOP MANUAL

6111283M2 - English - January 2008

**820
860/880 SX & ELITE
970/980 ELITE
TX760B
TX860B
TX970B
TX980B**



TEREX®

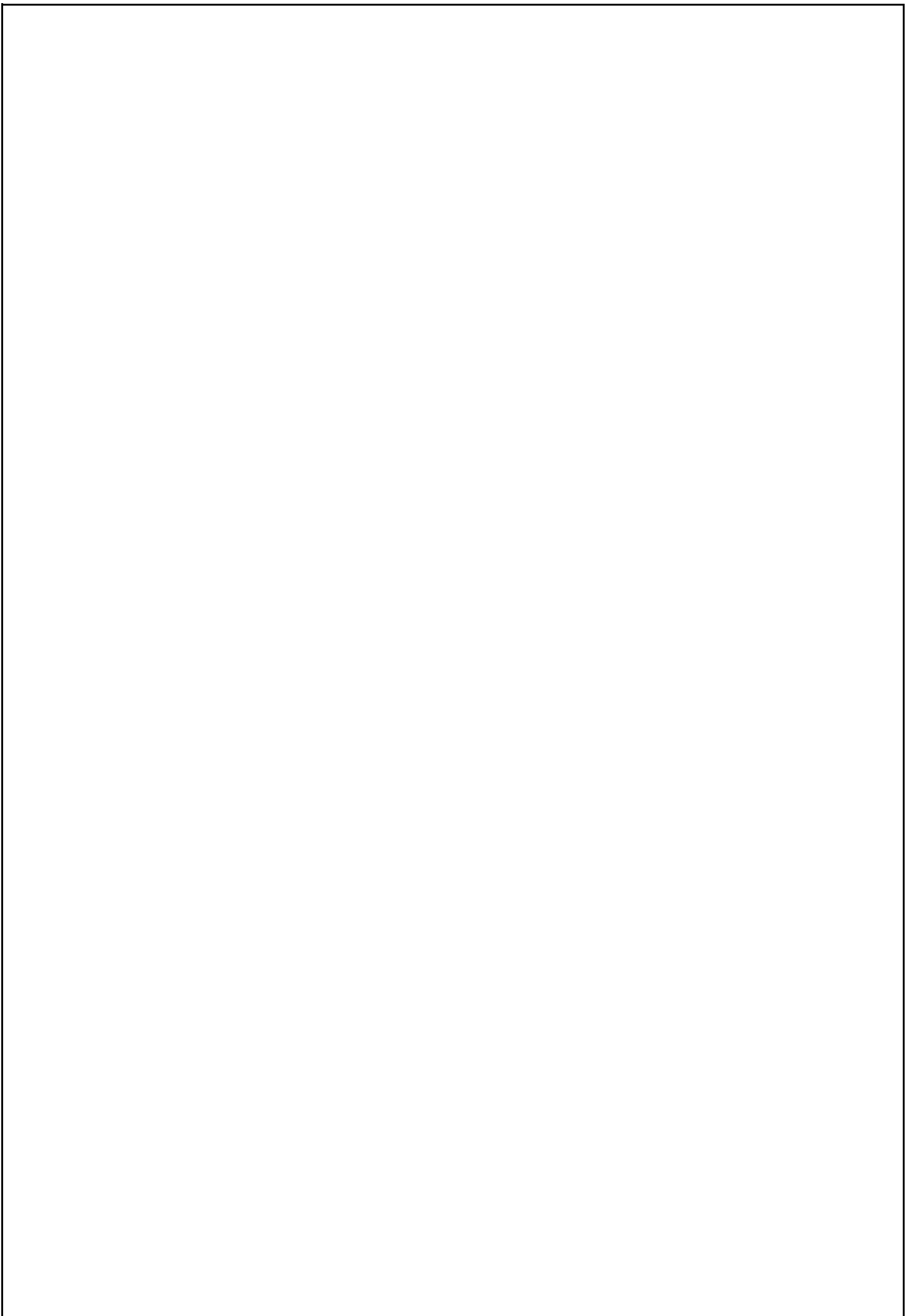

TABLE OF CONTENTS

<u>GENERAL INFORMATION</u>	0
GENERAL INFORMATION	0-01-2
GENERAL SAFETY	0-01-19
<u>ACCESSORIES</u>	A01
REMOVAL AND INSTALLATION — STANDARD LOADER BUCKET FROM A QUICK ATTACH UNIT	A01-01-1
REMOVAL AND INSTALLATION — MULTI PURPOSE LOADER BUCKET FROM A QUICK ATTACH UNIT	A01-01-3
REMOVAL AND INSTALLATION — QUICK ATTACH LOADER UNIT	A01-01-5
REMOVAL AND INSTALLATION — QUICK ATTACH LOADER UNIT HYDRAULIC CYLINDER	A01-01-9
SPECIFICATIONS — ACCESSORIES	A01-01-11
DESCRIPTION AND OPERATION — HOSE BURST VALVES	A01-02-1
REMOVAL AND INSTALLATION — LOADER BEAM HYDRAULIC CYLINDERS BURST VALVES	A01-02-3
REMOVAL AND INSTALLATION — LOADER BUCKET CROWD HYDRAULIC CYLINDER BURST VALVE	A01-02-5
REMOVAL AND INSTALLATION — BACKHOE DIPPER ARM CYLINDER BURST VALVE	A01-02-9
REMOVAL AND INSTALLATION — BACKHOE BOOM CYLINDER BURST VALVE	A01-02-11
SPECIFICATIONS — HOSE BURST VALVES	A01-02-13
<u>BUCKETS</u>	B02
REMOVAL AND INSTALLATION — STANDARD LOADER BUCKET	B02-01-1
REMOVAL AND INSTALLATION — MULTI PURPOSE LOADER BUCKET	B02-01-3
REMOVAL AND INSTALLATION — MULTI PURPOSE LOADER BUCKET CLAMPING CYLINDER	B02-01-7
DISASSEMBLY AND ASSEMBLY — MULTI-PURPOSE LOADER BUCKET	B02-01-9
DISASSEMBLY AND ASSEMBLY — MULTI-PURPOSE LOADER BUCKET CLAMPING CYLINDER	B02-01-15
SPECIFICATIONS — BUCKETS	B02-01-19
<u>DIGGER QUICK ATTACH</u>	C03
REMOVAL AND INSTALLATION — QUICK ATTACH BACKHOE BUCKET	C03-01-1
REMOVAL AND INSTALLATION — BACKHOE QUICK ATTACH UNIT	C03-01-3
REMOVAL AND INSTALLATION — BACKHOE QUICK ATTACH UNIT CONTROL VALVE	C03-01-5
REMOVAL AND INSTALLATION — BACKHOE QUICK ATTACH UNIT HYDRAULIC CYLINDER	C03-01-7
DISASSEMBLY AND ASSEMBLY — QUICK ATTACH HYDRAULIC CYLINDER	C03-01-9
SPECIFICATIONS — DIGGER QUICK ATTACH	C03-01-13
<u>DIGGER BOOM AND DIPPERSTICK</u>	D04
REMOVAL AND INSTALLATION — STANDARD BACKHOE BUCKET	D04-01-1
REMOVAL AND INSTALLATION — BACKHOE BOOM	D04-01-3
REMOVAL AND INSTALLATION — BACKHOE DIPPER ARM	D04-01-7
REMOVAL AND INSTALLATION — BOOM SWING TOWER	D04-01-11
DISASSEMBLY AND ASSEMBLY — EXTENDABLE DIPPER ARM HYDRAULIC CYLINDER	D04-01-15
GENERAL PROCEDURE — BACKHOE CONTROL LEVER ADJUSTMENT	D04-01-19
GENERAL PROCEDURE — AUXILIARY FUNCTION/TELESCOPIC DIPPER CONTROL PEDAL ADJUSTMENT	D04-01-23
SPECIFICATIONS — DIGGER BOOM AND DIPPERSTICK	D04-01-25
<u>DIGGER SWING SYSTEM</u>	E05
REMOVAL AND INSTALLATION — MAST CASTING	E05-01-1

TABLE OF CONTENTS

REMOVAL AND INSTALLATION — MAST CASTING CLAMP SEALS	E05-01-5
REMOVAL AND INSTALLATION — STABILIZER LEG (CENTREMOUNT)	E05-01-9
REMOVAL AND INSTALLATION — STABILIZER LEG (CENTREMOUNT) CYLINDER	E05-01-11
REMOVAL AND INSTALLATION — STABILIZER LEG (SIDESHIFT)	E05-01-13
REMOVAL AND INSTALLATION — STABILIZER LEG HYDRAULIC CYLINDER (SIDESHIFT)	E05-01-17
DISASSEMBLY AND ASSEMBLY — DIPPER HYDRAULIC CYLINDER	E05-01-21
DISASSEMBLY AND ASSEMBLY — BACKHOE BUCKET HYDRAULIC CYLINDER	E05-01-25
DISASSEMBLY AND ASSEMBLY — BOOM HYDRAULIC CYLINDER	E05-01-29
DISASSEMBLY AND ASSEMBLY — SLEW HYDRAULIC CYLINDER	E05-01-33
DISASSEMBLY AND ASSEMBLY — STABILIZER HYDRAULIC CYLINDER (SIDESHIFT)	E05-01-37
DISASSEMBLY AND ASSEMBLY — STABILIZER LEG HYDRAULIC CYLINDER (CENTREMOUNT)	E05-01-41
GENERAL PROCEDURE — CHECKING AND ADJUSTING THE EXTENDABLE DIPPER LOWER EXTERNAL WEAR PADS	E05-01-45
GENERAL PROCEDURE — CHECKING AND ADJUSTING THE EXTENDABLE DIPPER UPPER EXTERNAL WEAR PADS	E05-01-49
GENERAL PROCEDURE — CHECKING AND ADJUSTING THE EXTENDABLE DIPPER UPPER INTERNAL WEAR PADS	E05-01-51
GENERAL PROCEDURE — STABILIZER LEG WEAR PADS (SIDESHIFT)	E05-01-57
GENERAL PROCEDURE — STABILIZER LEGS CONTROL LEVER ADJUSTMENT	E05-01-61
GENERAL PROCEDURE — BOOM LATCH CABLE ADJUSTMENT	E05-01-65
SPECIFICATIONS — DIGGER SWING SYSTEM	E05-01-67

MAIN HYDRAULICS

F06

HYDRAULIC SYSTEM DIAGRAM	F06-01-1
DIAGNOSING AND TESTING — HYDRAULICS/PRESSURE TESTING	F06-01-5
DIAGNOSING AND TESTING — HYDRAULIC OIL CONTAMINATION	F06-01-19
REMOVAL AND INSTALLATION — HYDRAULIC OIL RESERVOIR	F06-01-21
REMOVAL AND INSTALLATION — OIL COOLER	F06-01-23
REMOVAL AND INSTALLATION — HYDRAULIC PUMP	F06-01-25
REMOVAL AND INSTALLATION — HYDRAULIC PUMP 2007	F06-01-29
REMOVAL AND INSTALLATION — BACKHOE CONTROL VALVE BANK	F06-01-33
REMOVAL AND INSTALLATION — LOADER CONTROL VALVE	F06-01-39
REMOVAL AND INSTALLATION — CHANGEOVER VALVE	F06-01-43
REMOVAL AND INSTALLATION — STEERING PRIORITY/UNLOADER VALVE	F06-01-45
REMOVAL AND INSTALLATION — RIDE CONTROL VALVE	F06-01-47
REMOVAL AND INSTALLATION — SERVO CONTROL VALVE	F06-01-49
REMOVAL AND INSTALLATION — SERVO CONTROL CONFIGURATION CHANGEOVER VALVE.	F06-01-51
DISASSEMBLY AND ASSEMBLY — HYDRAULIC PUMP	F06-01-55
DISASSEMBLY AND ASSEMBLY — HYDRAULIC PUMP - 2007	F06-01-59
DISASSEMBLY AND ASSEMBLY — BACKHOE CONTROL VALVE	F06-01-63
DISASSEMBLY AND ASSEMBLY — LOADER CONTROL VALVE	F06-01-75
DISASSEMBLY AND ASSEMBLY — CHANGEOVER VALVE	F06-01-81
DISASSEMBLY AND ASSEMBLY — RIDE CONTROL VALVE	F06-01-83
DISASSEMBLY AND ASSEMBLY — SERVO CONTROL VALVE	F06-01-85
GENERAL PROCEDURE — HYDRAULIC CYLINDER INSPECTION	F06-01-87
GENERAL PROCEDURE — CLEANING THE HYDRAULIC SYSTEM	F06-01-89
GENERAL PROCEDURE — FLUSHING WATER FROM THE HYDRAULIC SYSTEM	F06-01-91
GENERAL PROCEDURE — RELEASING THE HYDRAULIC SYSTEM PRESSURE	F06-01-95
GENERAL PROCEDURE — HYDRAULIC CYLINDER RING LUG EXTRACTION	F06-01-97
SPECIFICATIONS — MAIN HYDRAULIC SYSTEM	F06-01-99

LOADER

G07

REMOVAL AND INSTALLATION — FRONT LOADER BEAM	G07-01-1
REMOVAL AND INSTALLATION — LOADER BEAM HYDRAULIC CYLINDER	G07-01-7

TABLE OF CONTENTS

REMOVAL AND INSTALLATION — FRONT LOADER HYDRAULIC CROWD CYLINDER	G07-01-9
REMOVAL AND INSTALLATION — LOADER BUCKET POTENTIOMETER	G07-01-13
DISASSEMBLY AND ASSEMBLY — LOADER BUCKET HYDRAULIC CYLINDER	G07-01-15
GENERAL PROCEDURE — ANTI ROLLBACK ADJUSTMENT	G07-01-19
GENERAL PROCEDURE — RETURN TO DIG ADJUSTMENT	G07-01-21
SPECIFICATIONS — LOADER	G07-01-23

OPERATORS ENVIRONMENT

H08

REMOVAL AND INSTALLATION — CAB	H08-01-1
REMOVAL AND INSTALLATION — CAB HEATER AIR DUCTING	H08-01-13
REMOVAL AND INSTALLATION — CAB HEATER MOTOR	H08-01-17
REMOVAL AND INSTALLATION — CAB HEATER MATRIX	H08-01-19
REMOVAL AND INSTALLATION — DRIVER SEAT (ALL MODELS)	H08-01-23
REMOVAL AND INSTALLATION — CAB DOOR GLAZING PANEL	H08-01-25
REMOVAL AND INSTALLATION — AIR CONDITIONING EVAPORATOR	H08-01-27
REMOVAL AND INSTALLATION — REAR WINDOW OPEN POSITION LATCH	H08-01-31
REMOVAL AND INSTALLATION — SERVO CONTROL JOYSYICK	H08-01-33
REMOVAL AND INSTALLATION — CONTROLS TILT PEDAL	H08-01-37
REMOVAL AND INSTALLATION — HOSE REMOVAL AND INSTALLATION	H08-01-41
GENERAL PROCEDURE — AIR CONDITIONING RECOVERY AND CHARGING	H08-01-45
SPECIFICATIONS — OPERATORS ENVIRONMENT	H08-01-49

ELECTRICS

J09

DIAGNOSING AND TESTING — STARTING SYSTEM	J09-01-1
DIAGNOSING AND TESTING — CHARGING SYSTEM	J09-01-5
DIAGNOSING AND TESTING — BATTERY	J09-01-7
REMOVAL AND INSTALLATION — BATTERY (SINGLE)	J09-01-11
REMOVAL AND INSTALLATION — BATTERY (TWIN)	J09-01-13
REMOVAL AND INSTALLATION — STARTER MOTOR	J09-01-15
REMOVAL AND INSTALLATION — STARTER MOTOR SOLENOID	J09-01-17
REMOVAL AND INSTALLATION — ALTERNATOR	J09-01-19
REMOVAL AND INSTALLATION — FRONT WIPER MOTOR	J09-01-21
REMOVAL AND INSTALLATION — REAR WIPER MOTOR	J09-01-25
REMOVAL AND INSTALLATION — INDICATOR SWITCH	J09-01-27
REMOVAL AND INSTALLATION — FORWARD/REVERSE SWITCH	J09-01-29
GENERAL PROCEDURE — BATTERY ISOLATION	J09-01-33
GENERAL PROCEDURE — BATTERY CHARGING	J09-01-35
SPECIFICATIONS — ELECTRICS	J09-01-43
GENERAL ELECTRICAL INFORMATION	J09-02-1
FUSE AND RELAY INFORMATION	J09-02-5
CONNECTOR INFORMATION	J09-02-9
COMPONENT LOCATIONS	J09-02-33
WIRING DIAGRAMS — POWER SUPPLY	J09-02-47
WIRING DIAGRAMS — ENGINE	J09-02-51
WIRING DIAGRAMS — TRANSMISSION	J09-02-53
WIRING DIAGRAMS — DIFFERENTIAL LOCK	J09-02-57
WIRING DIAGRAMS — STEERING	J09-02-61
WIRING DIAGRAMS — CONSOLE PANELS	J09-02-63
WIRING DIAGRAMS — LIGHTING	J09-02-69
WIRING DIAGRAMS — WARNING FUNCTIONS	J09-02-83
WIRING DIAGRAMS — OPERATORS ENVIRONMENT	J09-02-87
WIRING DIAGRAMS — HYDRAULIC SYSTEMS	J09-02-93
WIRING DIAGRAMS — SERVO LEVER CONTROL	J09-02-103
CONNECTOR LOCATIONS	J09-02-105

TABLE OF CONTENTS

CHASSIS AND BODYWORK

K10

REMOVAL AND INSTALLATION — REAR FENDER	K10-01-1
REMOVAL AND INSTALLATION — HARDNOSE / TOOL BOX	K10-01-3
REMOVAL AND INSTALLATION — HOOD	K10-01-5
REMOVAL AND INSTALLATION — FRONT FENDER	K10-01-7
SPECIFICATIONS — CHASSIS AND BODYWORK	K10-01-9

FRONT AXLE AND STEER SYSTEM

L11

DESCRIPTION AND OPERATION — TWO-WHEEL DRIVE FRONT AXLE	L11-01-1
DIAGNOSING AND TESTING — TWO-WHEEL DRIVE FRONT AXLE	L11-01-3
REMOVAL AND INSTALLATION — TWO-WHEEL DRIVE FRONT AXLE	L11-01-5
REMOVAL AND INSTALLATION — STEERING CYLINDER GROUP	L11-01-9
DISASSEMBLY AND ASSEMBLY — STEERING CYLINDER GROUP	L11-01-11
DISASSEMBLY AND ASSEMBLY — WHEEL HUB GROUP	L11-01-13
DISASSEMBLY AND ASSEMBLY — AXLE BEAM GROUP	L11-01-21
GENERAL PROCEDURE — TOE-IN ADJUSTMENT	L11-01-25
SPECIFICATIONS — TWO-WHEEL DRIVE FRONT AXLE	L11-01-27
DESCRIPTION AND OPERATION — FOUR-WHEEL DRIVE FRONT AXLE	L11-02-1
DIAGNOSING AND TESTING — FOUR-WHEEL DRIVE FRONT AXLE	L11-02-3
REMOVAL AND INSTALLATION — FOUR-WHEEL DRIVE FRONT AXLE	L11-02-9
REMOVAL AND INSTALLATION — STEERING CYLINDER GROUP	L11-02-13
DISASSEMBLY AND ASSEMBLY — STEERING CYLINDER GROUP	L11-02-17
DISASSEMBLY AND ASSEMBLY — EPICYCLIC REDUCTION GEAR GROUP	L11-02-19
DISASSEMBLY AND ASSEMBLY — WHEEL HUB GROUP	L11-02-23
DISASSEMBLY AND ASSEMBLY — AXLE HOUSING GROUP	L11-02-33
DISASSEMBLY AND ASSEMBLY — DIFFERENTIAL SUPPORT GROUP	L11-02-37
DISASSEMBLY AND ASSEMBLY — DIFFERENTIAL GROUP	L11-02-49
DISASSEMBLY AND ASSEMBLY — PINION GROUP	L11-02-53
GENERAL PROCEDURE — TOE-IN ADJUSTMENT	L11-02-61
GENERAL PROCEDURE — STEERING ANGLE ADJUSTMENT	L11-02-63
GENERAL PROCEDURE — DRAINING AND FILLING THE FRONT AXLE HOUSING OIL	L11-02-65
GENERAL PROCEDURE — DRAINING AND FILLING THE HUB OIL	L11-02-67
SPECIFICATIONS — FOUR-WHEEL DRIVE FRONT AXLE	L11-02-69
DESCRIPTION AND OPERATION — FOUR-WHEEL STEER FRONT AXLE	L11-03-1
DIAGNOSING AND TESTING — FOUR-WHEEL STEER FRONT AXLE	L11-03-3
REMOVAL AND INSTALLATION — FOUR-WHEEL STEER FRONT AXLE	L11-03-9
DISASSEMBLY AND ASSEMBLY — STEERING CYLINDER GROUP (FOUR-WHEEL STEER)	L11-03-13
DISASSEMBLY AND ASSEMBLY — EPICYCLIC REDUCTION GEAR GROUP (FOUR-WHEEL STEER)	L11-03-15
DISASSEMBLY AND ASSEMBLY — FRONT WHEEL HUB GROUP (FOUR-WHEEL STEER)	L11-03-21
DISASSEMBLY AND ASSEMBLY — AXLE BEAM GROUP (FOUR-WHEEL STEER)	L11-03-31
DISASSEMBLY AND ASSEMBLY — DIFFERENTIAL SUPPORT GROUP (FOUR-WHEEL STEER)	L11-03-37
DISASSEMBLY AND ASSEMBLY — DIFFERENTIAL GROUP (FOUR-WHEEL STEER)	L11-03-47
DISASSEMBLY AND ASSEMBLY — PINION GROUP (FOUR-WHEEL STEER)	L11-03-53
GENERAL PROCEDURE — TOE-IN ADJUSTMENT (FOUR-WHEEL STEER)	L11-03-63
GENERAL PROCEDURE — STEERING ANGLE ADJUSTMENT (FOUR-WHEEL STEER)	L11-03-65
GENERAL PROCEDURE — DRAINING AND FILLING THE FRONT AXLE HOUSING OIL (FOUR-WHEEL STEER)	L11-03-67
GENERAL PROCEDURE — DRAINING AND FILLING THE HUB OIL (FOUR-WHEEL STEER)	L11-03-69
SPECIFICATIONS — FOUR WHEEL STEER FRONT AXLE	L11-03-71
DESCRIPTION AND OPERATION — TWO-WHEEL STEER	L11-04-1
DESCRIPTION AND OPERATION — FOUR-WHEEL STEER	L11-04-3
REMOVAL AND INSTALLATION — STEERING COLUMN	L11-04-9

TABLE OF CONTENTS

REMOVAL AND INSTALLATION — ORBITROL STEERING MOTOR UP TO 2007	L11-04-15
REMOVAL AND INSTALLATION — ORBITROL STEERING MOTOR 2007 ONWARDS	L11-04-19
REMOVAL AND INSTALLATION — FOUR-WHEEL STEER (4WS) CHANGEOVER VALVE	L11-04-21
REMOVAL AND INSTALLATION — TIE ROD END	L11-04-23
GENERAL PROCEDURE — FOUR-WHEEL STEER MISALIGNMENT CORRECTION	L11-04-25
SPECIFICATIONS — STEERING	L11-04-27
DESCRIPTION AND OPERATION — FOUR-WHEEL DRIVE FRONT AXLE	L11-05-1
DIAGNOSING AND TESTING — FOUR-WHEEL DRIVE FRONT AXLE	L11-05-3
REMOVAL AND INSTALLATION — FOUR-WHEEL DRIVE FRONT AXLE	L11-05-9
REMOVAL AND INSTALLATION — STEERING CYLINDER GROUP	L11-05-13
DISASSEMBLY AND ASSEMBLY — STEERING CYLINDER GROUP	L11-05-17
DISASSEMBLY AND ASSEMBLY — EPICYCLIC REDUCTION GEAR GROUP	L11-05-19
DISASSEMBLY AND ASSEMBLY — WHEEL HUB GROUP	L11-05-23
DISASSEMBLY AND ASSEMBLY — AXLE HOUSING GROUP	L11-05-35
DISASSEMBLY AND ASSEMBLY — DIFFERENTIAL SUPPORT GROUP	L11-05-39
DISASSEMBLY AND ASSEMBLY — DIFFERENTIAL GROUP	L11-05-51
DISASSEMBLY AND ASSEMBLY — PINION GROUP	L11-05-55
GENERAL PROCEDURE — TOE-IN ADJUSTMENT	L11-05-63
GENERAL PROCEDURE — STEERING ANGLE ADJUSTMENT	L11-05-65
GENERAL PROCEDURE — DRAINING AND FILLING THE FRONT AXLE HOUSING OIL	L11-05-67
GENERAL PROCEDURE — DRAINING AND FILLING THE HUB OIL	L11-05-69
SPECIFICATIONS — FOUR-WHEEL DRIVE FRONT AXLE	L11-05-71

WHEELS AND TYRES

M12

SAFETY PRECAUTIONS — WHEELS AND TYRES	M12-01-1
REMOVAL AND INSTALLATION — FRONT WHEEL	M12-01-3
REMOVAL AND INSTALLATION — REAR WHEEL	M12-01-5
REMOVAL AND INSTALLATION — INNER TUBE	M12-01-7
REMOVAL AND INSTALLATION — TYRE	M12-01-11
SPECIFICATIONS — WHEELS AND TYRES	M12-01-13

DRIVETRAIN AND BRAKES

N13

DESCRIPTION AND OPERATION — POWERSHIFT TRANSMISSION	N13-01-1
DIAGNOSING AND TESTING — POWERSHIFT TRANSMISSION	N13-01-19
DIAGNOSING AND TESTING — POWERSHIFT TRANSMISSION PRESSURE TESTING	N13-01-35
REMOVAL AND INSTALLATION — POWERSHIFT TRANSMISSION	N13-01-45
DISASSEMBLY AND ASSEMBLY — POWERSHIFT TRANSMISSION	N13-01-53
DISASSEMBLY AND ASSEMBLY — FORWARD LOW CLUTCH	N13-01-77
DISASSEMBLY AND ASSEMBLY — 1ST CLUTCH	N13-01-89
DISASSEMBLY AND ASSEMBLY — REVERSE CLUTCH	N13-01-101
DISASSEMBLY AND ASSEMBLY — 2ND CLUTCH	N13-01-113
DISASSEMBLY AND ASSEMBLY — OUTPUT SHAFT	N13-01-125
DISASSEMBLY AND ASSEMBLY — DISCONNECT SHAFT	N13-01-135
DISASSEMBLY AND ASSEMBLY — CHARGING PUMP DRIVE SHAFT	N13-01-139
DISASSEMBLY AND ASSEMBLY — INPUT SHAFT	N13-01-143
DISASSEMBLY AND ASSEMBLY — TRANSMISSION CONTROL VALVE	N13-01-149
GENERAL PROCEDURE — CLEANING AND INSPECTION AFTER TRANSMISSION REPAIR	N13-01-151
GENERAL PROCEDURE — POWERSHIFT TRANSMISSION CLUTCH CALIBRATION	N13-01-153
SPECIFICATIONS — POWERSHIFT TRANSMISSION	N13-01-157
DESCRIPTION AND OPERATION — SYNCHROSHUTTLE TRANSMISSION — TURNER	N13-02-1
DIAGNOSING AND TESTING — SYNCHROSHUTTLE TRANSMISSION	N13-02-10
DIAGNOSING AND TESTING — SYNCHROSHIFT TRANSMISSION PRESSURE TESTING	N13-02-13
REMOVAL AND INSTALLATION — SYNCHROSHIFT TRANSMISSION	N13-02-15
DISASSEMBLY AND ASSEMBLY — SYNCROSHIFT TRANSMISSION	N13-02-23
DISASSEMBLY AND ASSEMBLY — INPUT SHAFT	N13-02-47

TABLE OF CONTENTS

DISASSEMBLY AND ASSEMBLY — COUNTERSHAFT	N13-02-65
DISASSEMBLY AND ASSEMBLY — REVERSE IDLER SHAFT	N13-02-67
DISASSEMBLY AND ASSEMBLY — OUTPUT SHAFT	N13-02-69
DISASSEMBLY AND ASSEMBLY — HYDRAULIC MULTIPLATE CLUTCH FOUR-WHEEL DRIVE SHAFT	N13-02-77
DISASSEMBLY AND ASSEMBLY — DIRECTION CONTROL VALVE	N13-02-89
DISASSEMBLY AND ASSEMBLY — GEAR LEVER HOUSING	N13-02-93
SPECIFICATIONS — SYNCHROSHIFT TRANSMISSION	N13-02-95
DESCRIPTION AND OPERATION — HYDRAULIC BRAKING SYSTEM	N13-03-1
DESCRIPTION AND OPERATION — HYDRAULIC BRAKING SYSTEM SAFIM	N13-03-3
REMOVAL AND INSTALLATION — MASTER CYLINDER (POWER BRAKES)	N13-03-5
REMOVAL AND INSTALLATION — MASTER CYLINDER (SAFIM BRAKES)	N13-03-7
REMOVAL AND INSTALLATION — BRAKE FLUID RESERVOIR (SAFIM BRAKES)	N13-03-11
REMOVAL AND INSTALLATION — PARKING BRAKE CALIPER	N13-03-13
REMOVAL AND INSTALLATION — PARKING BRAKE DISC	N13-03-15
REMOVAL AND INSTALLATION — DIFFERENTIAL LOCK SOLENOID VALVE	N13-03-17
GENERAL PROCEDURE — BRAKE BLEEDING POWER BRAKES	N13-03-19
GENERAL PROCEDURE — BRAKE BLEEDING SAFIM BRAKES	N13-03-21
SPECIFICATIONS — POWER BRAKES	N13-03-23
SPECIFICATIONS — BRAKES - SAFIM	N13-03-25
DESCRIPTION AND OPERATION — TWO-WHEEL STEER REAR AXLE	N13-04-1
DIAGNOSING AND TESTING — TWO-WHEEL STEER REAR AXLE	N13-04-3
REMOVAL AND INSTALLATION — TWO WHEEL STEER REAR AXLE	N13-04-9
DISASSEMBLY AND ASSEMBLY — BRAKE CALIPER	N13-04-13
DISASSEMBLY AND ASSEMBLY — EPICYCLIC REDUCTION GEAR GROUP	N13-04-15
DISASSEMBLY AND ASSEMBLY — WHEEL HUB GROUP	N13-04-19
DISASSEMBLY AND ASSEMBLY — HALF SHAFT AND BRAKE GROUP	N13-04-25
DISASSEMBLY AND ASSEMBLY — DIFFERENTIAL GROUP	N13-04-33
DISASSEMBLY AND ASSEMBLY — PINION GROUP	N13-04-41
DISASSEMBLY AND ASSEMBLY — DIFFERENTIAL HOUSING GROUP	N13-04-51
GENERAL PROCEDURE — DRAINING AND FILLING THE REAR AXLE HOUSING OIL	N13-04-67
SPECIFICATIONS — TWO-WHEEL STEER REAR AXLE	N13-04-69
DESCRIPTION AND OPERATION — FOUR-WHEEL STEER REAR AXLE	N13-05-1
DIAGNOSING AND TESTING — FOUR-WHEEL STEER REAR AXLE	N13-05-3
REMOVAL AND INSTALLATION — FOUR-WHEEL STEER REAR AXLE	N13-05-9
REMOVAL AND INSTALLATION — STEERING CYLINDER (FOUR-WHEEL STEER)	N13-05-13
DISASSEMBLY AND ASSEMBLY — PARKING BRAKE CALIPER (FOUR-WHEEL STEER)	N13-05-15
DISASSEMBLY AND ASSEMBLY — EPICYCLIC REDUCTION GEAR GROUP (FOUR WHEEL-STEER)	N13-05-17
DISASSEMBLY AND ASSEMBLY — REAR WHEEL HUB GROUP (FOUR-WHEEL STEER)	N13-05-23
DISASSEMBLY AND ASSEMBLY — AXLE BEAM TRUMPETS AND BRAKE GROUP (FOUR-WHEEL STEER)	N13-05-31
DISASSEMBLY AND ASSEMBLY — DIFFERENTIAL GROUP (FOUR-WHEEL STEER)	N13-05-41
DISASSEMBLY AND ASSEMBLY — PINION GROUP (FOUR-WHEEL STEER)	N13-05-49
GENERAL PROCEDURE — TOE-IN ADJUSTMENT (FOUR-WHEEL STEER)	N13-05-59
GENERAL PROCEDURE — DRAINING AND FILLING THE REAR AXLE HOUSING OIL (FOUR-WHEEL STEER)	N13-05-61
GENERAL PROCEDURE — DRAINING AND FILLING THE HUB OIL (FOUR-WHEEL STEER)	N13-05-63
SPECIFICATIONS — FOUR-WHEEL STEER REAR AXLE	N13-05-65
DESCRIPTION AND OPERATION — SYNCHROSHUTTLE TRANSMISSION – CARRARO	N13-06-1
DIAGNOSING AND TESTING — SYNCHROSHUTTLE TRANSMISSION – CARRARO	N13-06-11
DIAGNOSING AND TESTING — SYNCHROSHUTTLE TRANSMISSION – CARRARO PRESSURE TESTING	N13-06-15
REMOVAL AND INSTALLATION — SYNCHROSHUTTLE TRANSMISSION — CARRARO	N13-06-19

TABLE OF CONTENTS

DISASSEMBLY AND ASSEMBLY — PLUGS AND FILTERS	N13-06-31
DISASSEMBLY AND ASSEMBLY — TRANSMISSION OIL PUMP	N13-06-39
DISASSEMBLY AND ASSEMBLY — HYDRAULIC CONTROL VALVE	N13-06-43
DISASSEMBLY AND ASSEMBLY — FOUR WHEEL DRIVE SOLENOID VALVE	N13-06-61
DISASSEMBLY AND ASSEMBLY — TRANSMISSION HOUSING	N13-06-65
DISASSEMBLY AND ASSEMBLY — INPUT SHAFT AND IDLER SHAFT	N13-06-83
DISASSEMBLY AND ASSEMBLY — SHAFTS C AND B	N13-06-105
DISASSEMBLY AND ASSEMBLY — FOUR WHEEL DRIVE SHAFT (E)	N13-06-129
DISASSEMBLY AND ASSEMBLY — SPEED CONTROLS	N13-06-139
SPECIFICATIONS — SYNCHROSHUTTLE TRANSMISSION — CARRARO	N13-06-145
DESCRIPTION AND OPERATION — CARRARO POWERSHIFT TRANSMISSION	N13-07-1
DIAGNOSING AND TESTING — CARRARO POWERSHIFT TRANSMISSION	N13-07-19
DIAGNOSING AND TESTING — CARRARO POWERSHIFT TRANSMISSION PRESSURE TESTING	N13-07-29
REMOVAL AND INSTALLATION — CARRARO POWERSHIFT TRANSMISSION	N13-07-33
DISASSEMBLY AND ASSEMBLY — CARRARO POWERSHIFT TRANSMISSION	N13-07-43
DISASSEMBLY AND ASSEMBLY — CARRARO POWERSHIFT FORWARD AND REVERSE CLUTCHES	N13-07-49
DISASSEMBLY AND ASSEMBLY — CARRARO POWERSHIFT 2ND SPEED CLUTCH	N13-07-67
DISASSEMBLY AND ASSEMBLY — CARRARO POWERSHIFT 1ST CLUTCH	N13-07-79
DISASSEMBLY AND ASSEMBLY — CARRARO POWERSHIFT 3RD AND 4TH SPEED CLUTCHES	N13-07-85
DISASSEMBLY AND ASSEMBLY — CARRARO POWERSHIFT 4WD CLUTCH	N13-07-103
DISASSEMBLY AND ASSEMBLY — CARRARO POWERSHIFT HYDRAULIC PUMP DRIVE SHAFT	N13-07-113
DISASSEMBLY AND ASSEMBLY — CARRARO POWERSHIFT TRANSMISSION CONTROL VALVE	N13-07-117
GENERAL PROCEDURE — CARRARO POWERSHIFT CLEANING AND INSPECTION AFTER TRANSMISSION REPAIR	N13-07-121
SPECIFICATIONS — CARRARO POWERSHIFT TRANSMISSION	N13-07-123

ENGINE

P14

DESCRIPTION AND OPERATION — ENGINE	P14-01-1
REMOVAL AND INSTALLATION — ENGINE	P14-01-3
REMOVAL AND INSTALLATION — ENGINE	P14-01-15
REMOVAL AND INSTALLATION — RADIATOR	P14-01-27
REMOVAL AND INSTALLATION — FUEL TANK	P14-01-31
REMOVAL AND INSTALLATION — AIR CLEANER	P14-01-33
REMOVAL AND INSTALLATION — EXHAUST PIPE	P14-01-35
REMOVAL AND INSTALLATION — EXHAUST SILENCER	P14-01-37
GENERAL PROCEDURE — THROTTLE ADJUSTMENT	P14-01-39
GENERAL PROCEDURE — DRAINING, FILLING AND BLEEDING THE COOLING SYSTEM	P14-01-41
SPECIFICATIONS — ENGINE	P14-01-43

GENERAL INFORMATION

0

SECTION

GENERAL INFORMATION	0-01-1
GENERAL SAFETY	0-01-19

GENERAL INFORMATION

GENERAL INFORMATION

BHA0001IA

Publication Date
January 2008

Revision Number
02.00.00

Service Techniques

General

The words 'front', 'rear', 'right-hand' and 'left-hand' used in this manual refer to the different parts of the machine as viewed from the Operator's seat, when facing the steering wheel.

Clean the exterior of all components before starting any type of repair. Dirt and abrasive dust can reduce the efficient working life of a component and lead to costly replacement.

Time spent on the preparation and cleanliness of working surfaces will pay dividends in making the job easier and safer and will result in overhauled components being more reliable and efficient in operation.

Use cleaning fluids which are known to be safe. Certain types of fluid can cause damage to O-rings and cause skin irritation. Solvents should be checked that they are suitable for the cleaning of components and also there is no risk to the personal safety of the user.

When replacing component parts, use the correct tool for the job.

Cleaning

Caution:

- **Care should be exercised to avoid skin rashes, fire hazards, and inhalation of vapours when using solvent type cleaners.**

Clean all parts thoroughly using solvent type cleaning fluid. It is recommended that parts be immersed in cleaning fluid and agitated until all old lubricant and foreign material is dissolved and the parts are thoroughly cleaned.

Bearings

Remove bearings from cleaning fluid and strike flat against a block of wood to dislodge solidified particles of lubricant. Immerse again in cleaning fluid to flush out particles. Repeat above operation until bearings are thoroughly clean. Dry bearings using moisture-free compressed air. Be careful to direct air stream across bearing to avoid spinning. **Do not spin bearings when drying**. Bearings may be rotated slowly by hand to facilitate the drying process.

Housings

Caution:

- **Care should be exercised to avoid inhalation of vapours and skin rashes when using alkali cleaners.**

Thoroughly clean interior and exterior of housings, bearing caps, etc. Cast parts may be cleaned in hot solution tanks with mild alkali solutions, provided these parts do not have ground or polished surfaces. Parts should remain in the solution long enough to be thoroughly cleaned and heated. This will aid the evaporation of the cleaning solution and rinse water.

Parts cleaned in solution tanks must be thoroughly rinsed with clean water to remove all traces of alkali. Cast parts may also be cleaned with a steam cleaner. All parts cleaned must be thoroughly dried immediately by using moisture-free compressed air or soft lint-free absorbent wiping rags, free of abrasive materials such as metal filings, contaminated oil or lapping compound.

Inspection

The importance of careful and thorough inspection of all parts cannot be overstressed. Replacement of all parts showing indication of wear or stress will eliminate costly and avoidable failures at a later date.

Bearings

Carefully inspect all rollers, cages and cups for wear, chipping, or nicks to determine fitness of bearings for further use. **Do not replace a bearing cone or cup individually** without replacing the mating cup or cone at the same time. After inspection, lubricate the bearings with suitable clean oil and wrap in clean lint-free cloth or paper to protect them until installed.

Oil Seals, Gaskets, Etc.

Replace O-rings, seals or gaskets whenever they are disturbed. Never mix new and old seals or O-rings, regardless of condition. Always lubricate new seals and O-rings with suitable clean oil before installation. Replacement of spring-load oil seals, O-rings, metal sealing rings, gaskets and snap rings is more economical when the unit is disassembled than premature overhaul to replace these parts at a future time.

Further loss of lubricant through a worn oil seal may result in failure of other more expensive parts of the assembly. Sealing members should be handled carefully, particularly when being installed. Cutting, scratching or curling under the lips of seals seriously reduces their efficiency.

When assembling new metal type sealing rings, these should be lubricated with a light grease to stabilise rings in their grooves for ease of assembly of mating members.

Gears and Shafts

Examine teeth on all gears carefully for wear, pitting, chipping, nicks, cracks or scores. If gear teeth show spots where case hardening is worn through or cracked, replaced with new gear. Small nicks may be removed with a suitable hone. Inspect shafts and quills to make certain they are not sprung, bent or spline-twisted, and that shafts are not bent.

Housings, Covers, Etc.

Inspect housings, covers and bearing cups to ensure that they are thoroughly clean and that mating surfaces, bearing bores, etc. are free from nicks or burrs. Check all parts carefully for evidence of cracks or conditions that would cause subsequent oil leaks or failures.

Hoses and Tubes

Always replace hoses and tubes if the cone end or the end connections on the hose are damaged.

When installing a new hose, loosely connect each end and make sure the hose takes up the designed position before tightening the connection. Clamps should be tightened sufficiently to hold the hose without crushing and to prevent chafing.

After hose replacement to a moving component, check the hose does not foul by moving the component through the complete range of travel.

Make sure any hose which has been installed is not kinked or twisted.

Hose connections which are damaged, dented, crushed or leaking, restrict oil flow and the productivity of the component being served. Connectors which show signs of movement from the original swagged position have failed and will ultimately separate completely.

A hose with a chafed outer cover will allow water to enter. Concealed corrosion of the wire reinforcement will subsequently occur along the hose length with resultant hose failure.

Ballooning of the hose indicates an internal leakage due to structural failure. This condition rapidly deteriorates and total hose failure will soon occur.

Kinked, crushed, stretched or deformed hoses generally suffer internal structural damage which can result in oil restriction, a reduction in the speed of operation and ultimately hose failure.

Free moving, unsupported hoses must never be allowed to touch each other or related working surfaces. This causes chafing which reduces hose life.

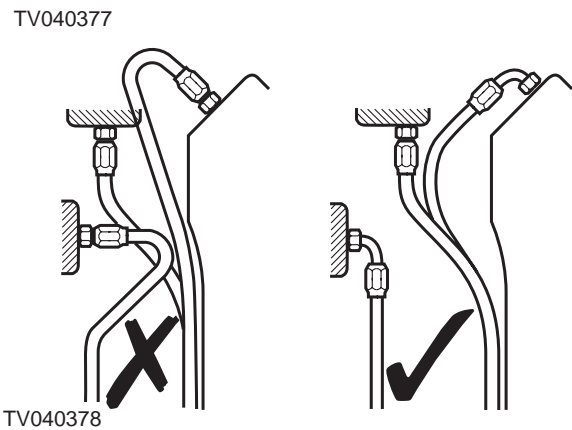
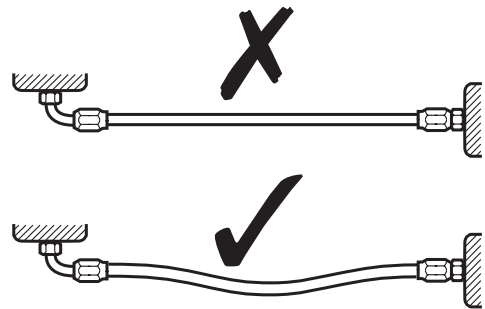
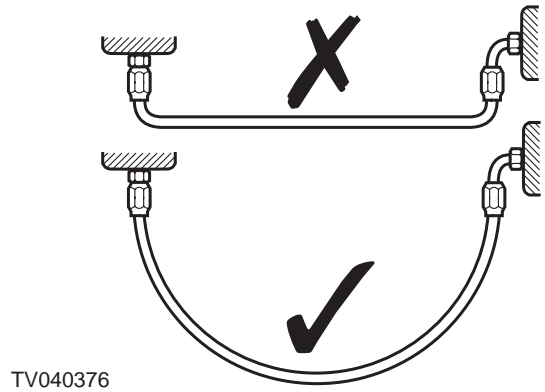
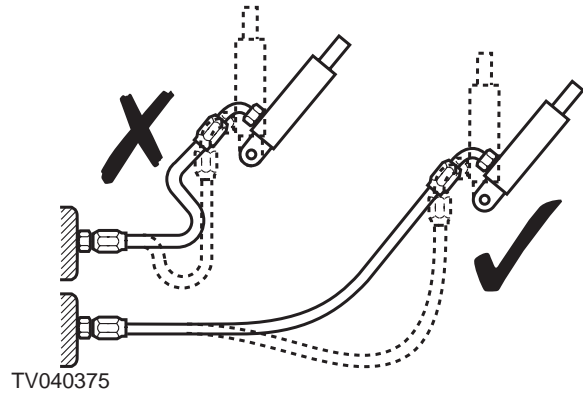

Installing Flexible Hoses

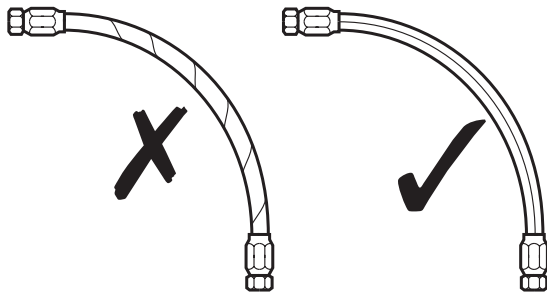

GENERAL INFORMATION

VIN Definition

Item	Digit	Description/Values	Example
Manufacturer ID	S	Registered with BSI	S
	M		M
	F		F
Product Variants	X	H =Terex/TCE, G =Fermec	H
Transmission	X	4 =4 Speed Synchro Shuttle, 3 =3 Speed Synchro Shuttle, 6 =4 Speed Power Shift, 5 =3 Speed Power Shift	5
Drive	X	4 =4WD, 2 =2WD	4
Digging Length	X	S =4.5 Std, T =4.5 Ext, L =4.9 Std, E =4.9 Ext, N =None	T
Operator Compartment	X	C =Cab, R =ROPS	C
Loader Element Function	X	0 =Mechanical, N =None	0
Production Year	X	BSA U175 Model Year, 1 =2001, 2 =2002, 3 =2003, 4 =2004 etc..	4
Chassis Type	X	See Table 1 Below	C
Engine Type	X	F =68.5 kW, G =74.5kW	G
Digging Element Function	X	M =Mechanical, N =None	M
Serial Number	X	Machine Serial Number	3, 6, 5, 7

Table 1 — Chassis Type

Digit	Type
A	2WS/Base/Sideshift (820)
B	2WS/Base/Centre Mount (820)
C	2WS/Main/Side Shift (860)
D	2WS/Main/Centre Mount (860)
E	4WS/Side Shift (970)
F	4WS/Centre Mount (970)

For additional information, refer to the Operator's Manual.

GENERAL INFORMATION

Fluids and Lubricants

Specifications

System	Temperatures		Viscosity	Specifications	Capacities (Litres)	Notes
	From	To				
Engine Turbocharged – 1100 Series 820/860/970	-40°C	+40°C	0W – 40	EMA DHD-1 or CH-4 API CH-4 ACEA E3 or E5	7.3	If sulphur content in fuel is above 0.2% of mass (2000ppm), change oil and filter every 250 hours)
	-30°C	+40°C	5W – 40			
	-10°C	+50°C	15W – 40			
Transmission Synchro Shuttle 820/860	ALL		10W	ATF	22 (Total System)	Check oil level with engine running at idle. Clean suction strainer at oil change
Transmission Powershift 860/970	ALL		10W	ATF	23 (Total System)	Check oil level with engine running at idle: Approved oils: ATF Elfmatic G3 Esso D (21611)
Front Axle 820/860	ALL		80W – 90	API GL5 MIL-L-2105D	6.5 + 1 + 1	As Alternative: Agip Rotra Multi THT Esso Torque Fluid 62 Mobil Fluid 422 or 424
Front Axle 970	ALL		80W – 90	API GL5 MIL-L-2105D	7.5 + 1 + 1	As Alternative: Agip Rotra Multi THT Esso Torque Fluid 62 Mobil Fluid 422 or 424
Rear Axle 820/860	ALL		80W	API GL4 M1135	14.5 + 1.5 + 1.5	Approved oils: Agip Rotra Multi THT Esso Torque Fluid 62 Mobil Fluid 422 or 424
Rear Axle 970	ALL		80W	API GL4 M1135	14.5 + 1.5 + 1.5	Approved oils: Agip Rotra Multi THT Esso Torque Fluid 62 Mobil Fluid 422 or 424
Hydraulics	Up to +30°C		ISO VG 46	DIN 51524	143 (Total System)	Tank Capacity = 85 Litre
	Up to +50°C		ISO VG 68			
Greasing – General	ALL		EP-NLGI	Grade 2		EP-Lithium based
Greasing - Backhoe swing	ALL		EP-NLGI	Grade 2		EP-Lithium based with Molybdenum disulphide (MoS2)

GENERAL INFORMATION

Greasing - Propeller Shafts	ALL	EP-NLGI	Grade 2		EP-Lithium based with Molybdenum disulphide (MoS2)
Greasing - Dive Shafts U.J					
Greasing - Axle(s) King Pins					
Coolant	Up to -33°C		BS 6580-1992 ASTM D3306	16 (Total System)	Antifreeze=33%
	Up to -50°C				Antifreeze=50%
Fuel	ALL			130	Cetane: Minimum 45 Sulphar content: Maximum 0.2% (of mass)
Air Conditioning			CFC 134 A	1200 gr (Initial Charge)	Recharge=900 – 1000gr

Service Schedule

System	Service Schedule (Hours)					
	10	50	250	500	1000	Yearly
Engine Turbocharged – 1100 Series 820/860/970	C			R		
Filter 2654403				R		
Transmission Synchro Shuttle 820/860		C			R	
Filter 6190810M1				R		
Transmission Powershift 860/970		C			R	
Filter 6193480M91					R	
Front Axle 820/860			C		R	
Front Axle 970			C		R	
Rear Axle 820/860			C		R	
Rear Axle 970			C		R	
Hydraulics		C			R	
Filter 3515328 M92					R	
Greasing – General	G					
Greasing - Backhoe swing	G					
Greasing - Propeller Shafts		G				
Greasing - Dive Shafts U.J			G			
Greasing - Axle(s) King Pins	G					
Coolant	C					C
Fuel					D (Tank)	
Filter 26560201				R		
Air Conditioning						C

C=Check, D=Drain, G=Grease, R=Replace

NOTE: Synchro Shuttle Transmission oil level is checked with the engine running at idle and hot oil.
NOTE: Distance from the flat on top of dipstick to the 'H' and 'L' marks 929mm respectively. Total length 952mm.

GENERAL INFORMATION

Sealing and Locking Fluids

Type	Description
Loctite 242	Medium strength thread lock
Loctite 243	Medium strength oil tolerant sealant
Loctite 270	Maximum strength stud lock
Loctite 496	Instant Adhesive
Loctite 510	High temperature flange sealant
Loctite 542	Fine thread sealant
Loctite 638	Maximum strength retaining compound
Loctite 648	High strength/rapid cure retaining compound

General Specifications

Engine

Engine	Low Power (820)	High Power (860 – 970)
Make	Perkins	
Model	1104C-44T	
Bore and Stroke	105x127mm	
Capacity	4400 cc	
Compression Ratio	16.5:1	
Firing Order	1 3 4 2	
Type	2164/2200	2166/2200
Build List (With Air Con)	RG38043	RG38044
Build List (Without Air Con)	RG38100	RG38099
Power @ 2200rpm	68.5kW (92 HP)	74.5kW (100 HP)
Torque @ 1400rpm	395Nm	415Nm
Turbocharger		
	Garrett GT 25, with wastegate	
Perkins P/N	2674A226	
Wastegate beginning to operate pressure	1.0 +/- 0.05bar	
Injection Pump		
	Delphi	
Model	DP210	
Type	1398/2644H013	1405/2644H023
Setting Code	XR/2/2350	DT/2/2350
Perkins Type	9320A212G	9320A342G
Perkins P/N	2644H002	2644H003
Injection Advance	0.5° BTDC	
Timing	Pin Timed 0° ATDC	
Speed at which cut off starts under full load	2200 +/- 25rpm	
Maximum No Load Speed	2350 +/- 25rpm	
Idle Speed	700 – 1200rpm	

GENERAL INFORMATION

Injectors	Delphi
Type	LJBX6921101
Perkins P/N (Nozzle)	2645K611
Opening Pressure	290 +/- 8bar
Colour Code	Yellow
Fuel Feed Pump Pressure	0.1 – 0.7bar
Valve Lash (Cold) – Inlet	0.20mm
Valve Lash (Cold) – Exhaust	0.45mm
Valve Arrangement	IE IE IE IE
Cold Start System	Glow Plugs (4)
Make	Beru
Perkins P/N	2666A016
Initial Current	30A Immediately Reduced to 21A
After 8 sec	14A
After 20 sec	10A
After 60 sec	9A
Cold Start Sensor	Normally Open
Perkins P/N	2848A127
Closes at	50 +/- 3°C
Re-opens at	40 +/- 3°C
Radiator Cap Pressure	110kPa
Thermostat	Wax Element By-pass Blanking
Perkins P/N	2485C041P
Nominal Temperature Stamped on Thermostat	82°C
Start to Open Temperature	79 – 84°C
Fully Open Temperature	93°C
Minimum Valve Lift Fully Open	10mm
Lubrication	Rotor Pump
Minimum Oil Pressure at Max rpm	3.0bar

Transmission

Transmission	Synchro Shuttle	Power Shift
Make	Turner	Dana
Model	COM-T4-2032	121-4FT 16000-22
Fermec P/N	6108873M91	6108875M91
Torque Converter Stall Ratio	3.01:1	2.60:1
Pump Pressure	18.0bar	20.5 – 23.5bar
Clutch Pressure	16bar	20.5 – 23.0bar
Torque Converter Working Pressure	–	4.9 – 5.0bar
Torque Converter Safety Valve Pressure	6.5 – 7.5bar	9.0bar
Solenoid Pressure	–	9.5bar
860 Transmission Control Unit	–	4503428
970 Transmission Control Unit	–	4503427
Lubrication Pressure	1.5 – 3.0bar	0.4 – 0.5bar

Brakes

Brakes	Oil Immersed Disk Type in the Rear Axle
Booster	Transmission Pressure Activated
Boost ratio	2.60:1
Master Cylinders Diameter	31.75mm (1 1/4")
Master cylinder seals	Specific for Mineral Oil
Brake Disks	
Friction Discs (820–860)	2 Each Side
Friction Discs (970)	3 Each Side
Brake Piston Seals	Specific for Mineral Oil