



PARTS MANUAL

FORKLIFT TRUCK

GAS & DIESEL POWERED

FG20c6H **FD20c6H**
FG20T6H **FD20T6H**
FG25c6H **FD25c6H**
FG25T6H **FD25T6H**

TCM CORPORATION

ご使用のまえに

このパーツマニュアルは、**TCM** **フォークリフト** の構成部品を収録しています。

部品ご注文について

部品ご注文の際は、必ず車両の形式・仕様・製造番号（号車）、部品番号および注文数を明示してください。車両の製造番号（号車）は車両銘板に表示しています。

製造番号（号車）

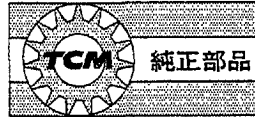
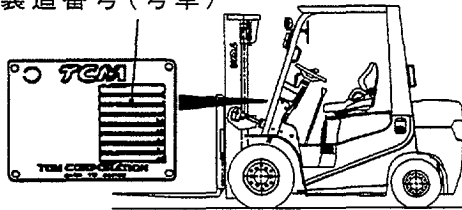

部品は、必ず「**TCM** 純正部品」をご使用ください。
純正部品以外の部品をご使用になり、故障が発生した場合は保証できません。

ご使用について

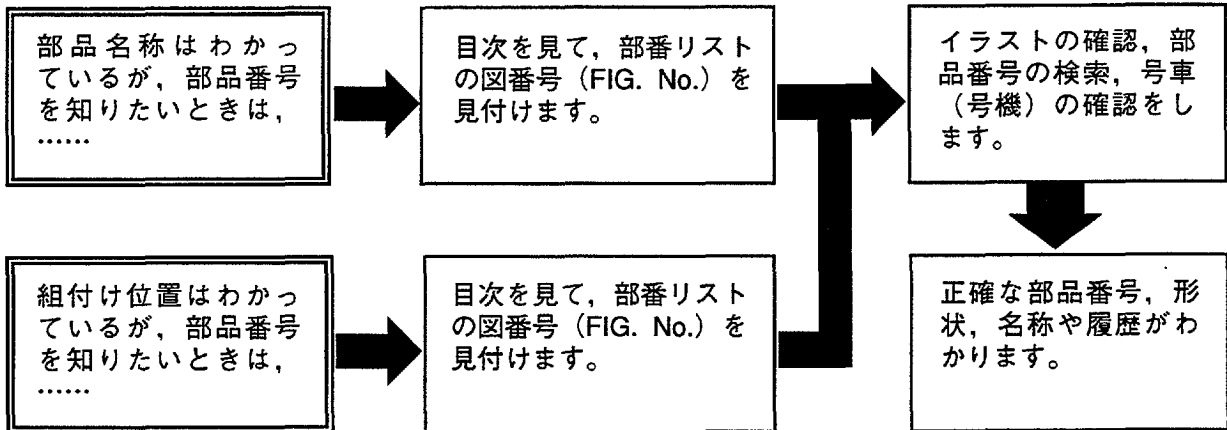

略語および記号

- ASSY 組立品を示します。
- RH 車両の前方向に向かって右側を示します。
- LH 車両の前方向に向かって左側を示します。
- AR 必要に応じた数を使用します。
- * セットおよびキットの販売部品を示します。
- T 厚みを示します。
- + 図示していません。
- # 単体販売しません。

部品は、品質向上のため予告なく変更することがありますので、あらかじめご了承ください。詳細は、**TCM** 指定整備工場にご相談ください。

INTRODUCTION

This Parts Manual contains the component parts of the **TCM FORKLIFT TRUCK**.

How to order parts

When ordering, be sure to specify the model name, specification and serial number (machine number) of your machine, as well as the part number and desired quantity for each part. The machine serial number (machine number) is indicated on the machine name plate.

Serial number
(machine number)

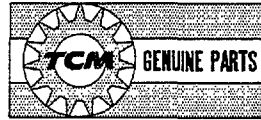
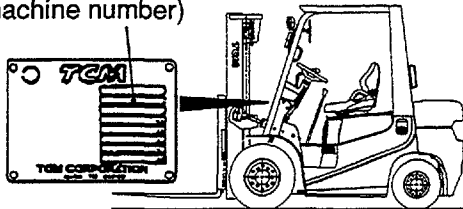

Always use "**TCM's** Genuine Parts". We cannot guarantee any loss or trouble attributable to other parts than ours.

How to use the Parts Manual

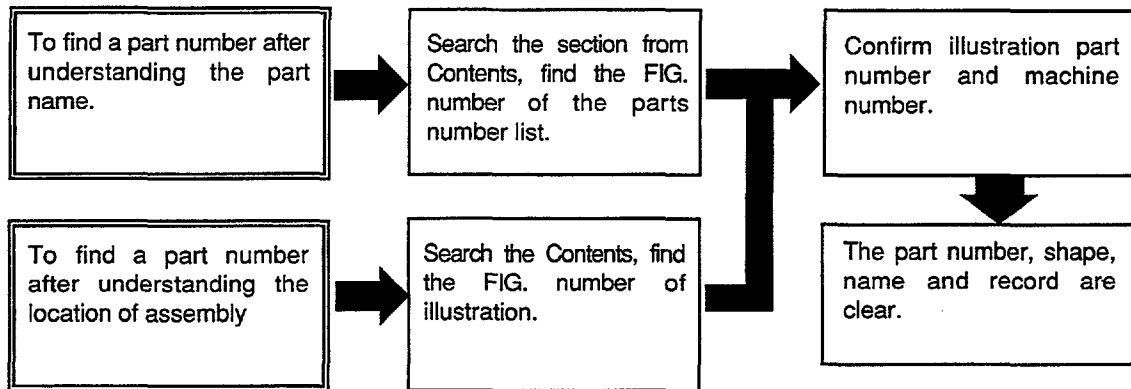

Abbreviations and symbols

ASSY ...	Assembled unit.
RH	Right-hand when viewed forward on the truck.
LH	Left-hand when viewed forward on the truck.
AR	Quantity required.
*	The marketable part set or kit.
T	Thickness.
+	Not illustrated.
#	Not sold separately.

Materials and specifications subject to change without notice.

Fig.1 ENGINE MOUNT
(F5H21010)

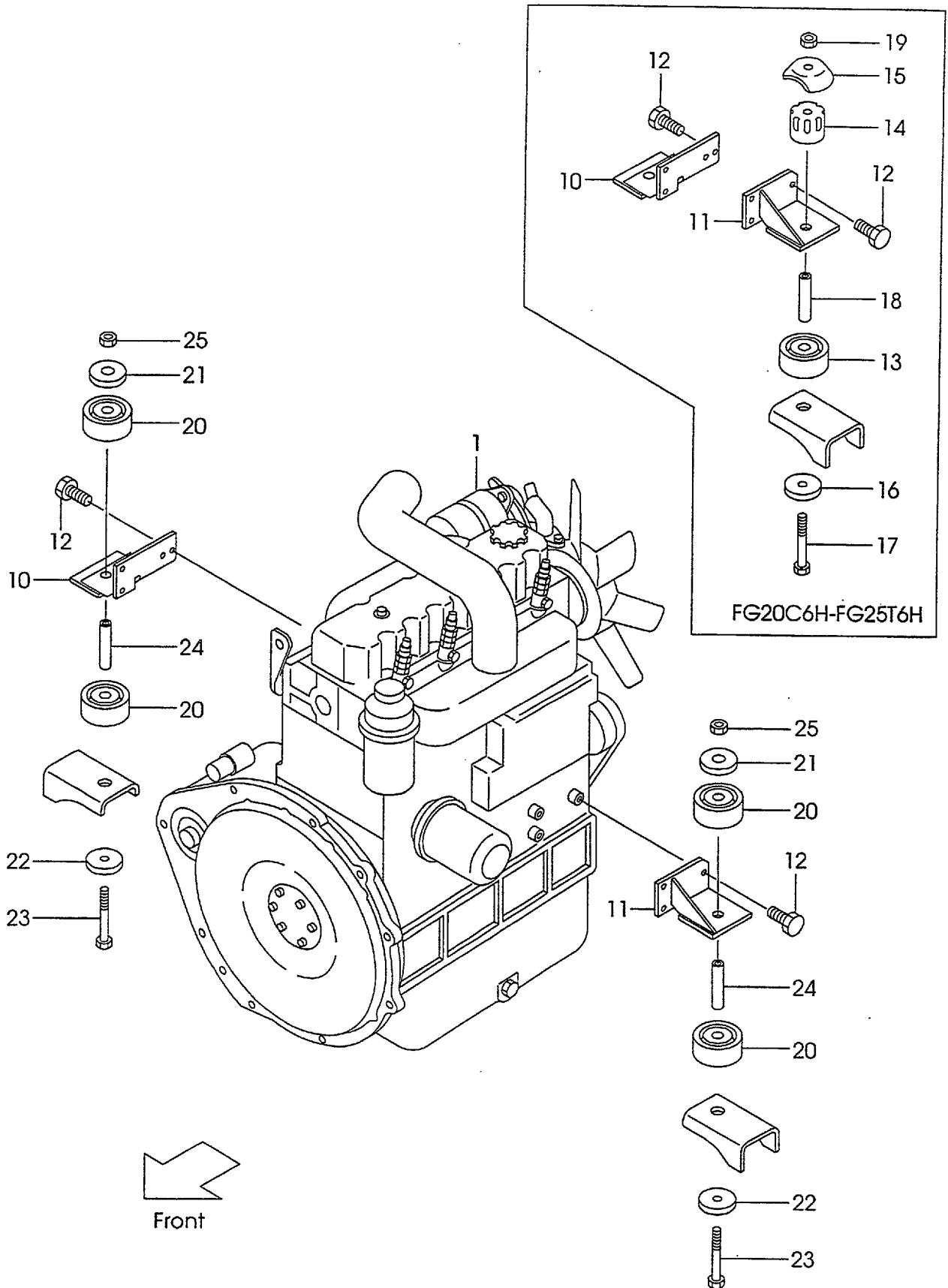

A:FG20C6H D:FG25T6H G:FD25C6H
 B:FG20T6H E:FD20C6H H:FD25T6H
 C:FG25C6H F:FD20T6H

Fig.1
 (F5H21010)

Item No	Part No.	Mark	Description	Req'd	Remarks : Serial No.
1	237A1-00101		ENGINE H25	1	A,C
-	237B1-00101		ENGINE H25	1	B,D
-	239A1-00101		ENGINE V3300	1	E,F,G,H
2	01400-00008	+	NUT	2	
3	02010-00008	+	WASHER	2	
4	02000-00008	+	WASHER	2	
5	01100-05010	+	BOLT	1	
6	02010-00005	+	WASHER	1	
7	01400-00006	+	NUT	1	E,F,G,H
8	02010-00006	+	WASHER	1	E,F,G,H
9	02000-00006	+	WASHER	1	E,F,G,H
10	218G1-02351		BRACKET,RH	1	A,B,C,D
-	239A1-02311		BRACKET,RH	1	E,F,G,H
11	218G1-02301		BRACKET,LH	1	A,B,C,D
-	239A1-02301		BRACKET,LH	1	E,F,G,H
12	01218-10025		BOLT	7	A,B,C,D
-	01219-12030		BOLT	7	E,F,G,H
13	216G1-02111		RUBBER,UNDER	2	A,B,C,D
14	214A1-02111		RUBBER,UPPER	2	A,B,C,D
15	214A1-02121		CAP	2	A,B,C,D
16	23651-02001		WASHER	2	A,B,C,D
17	01103-10110		BOLT	2	A,B,C,D
18	234A1-02071		COLLAR	2	A,B,C,D
19	23651-02011		NUT	2	A,B,C,D
20	216G1-02111		RUBBER	4	E,F,G,H
21	25782-52041		PLATE	2	E,F,G,H
22	23651-02001		WASHER	2	E,F,G,H
23	01103-10105		BOLT	2	E,F,G,H
24	239A1-02071		COLLAR	2	E,F,G,H
25	23651-02011		NUT	2	E,F,G,H

Fig.2 AIR CLEANER(G-TYPE)
(F5H21020)

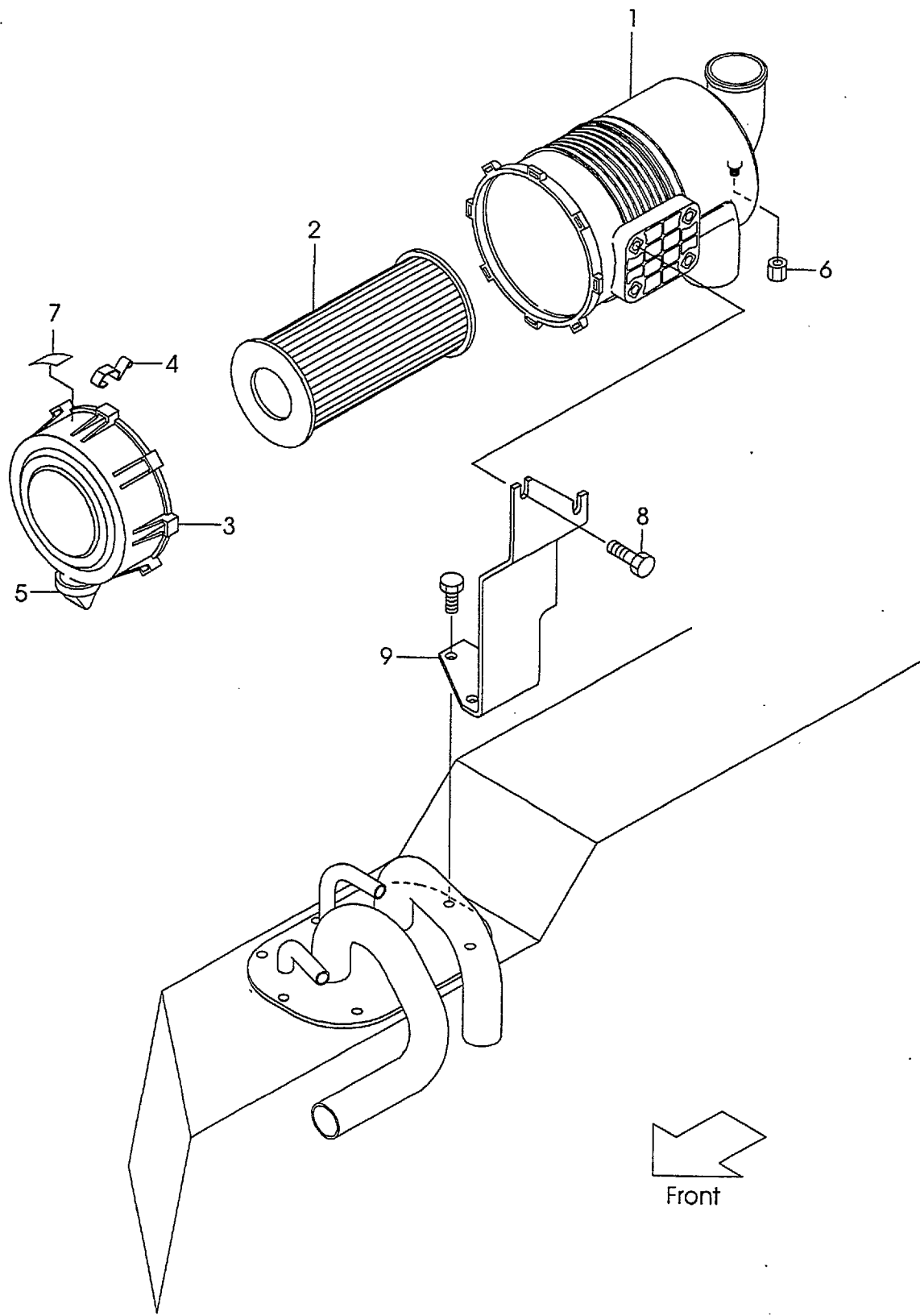

A:FG20C6H D:FG25T6H G:FD25C6H
B:FG20T6H E:FD20C6H H:FD25T6H
C:FG25C6H F:FD20T6H

Fig.2
(F5H21020)

Item No	Part No.	Mark	Description	Req'd	Remarks : Serial No.
A1	216G1-02451		CLEANER-ASSY,AIR	1	A,B,C,D INC.1-7
1	216G1-02481		BODY	1	A,B,C,D
2	256C1-08011		ELEMENT,AIR	1	A,B,C,D
3	216G1-02461		COVER	1	A,B,C,D
4	216G1-02471		LATCH	3	A,B,C,D
5	216G1-02491		VALVE,VACUATOR	1	A,B,C,D
6	53651-12551		CAP,NIPPLE	1	A,B,C,D
7	216G1-02501		LABEL	1	A,B,C,D
8	01183-08016		BOLT	4	A,B,C,D
9	237A1-02101		BRACKET,AIR-CLEANER	1	A,B,C,D

Fig.3 AIR CLEANER(D-TYPE)
(F5H21040)

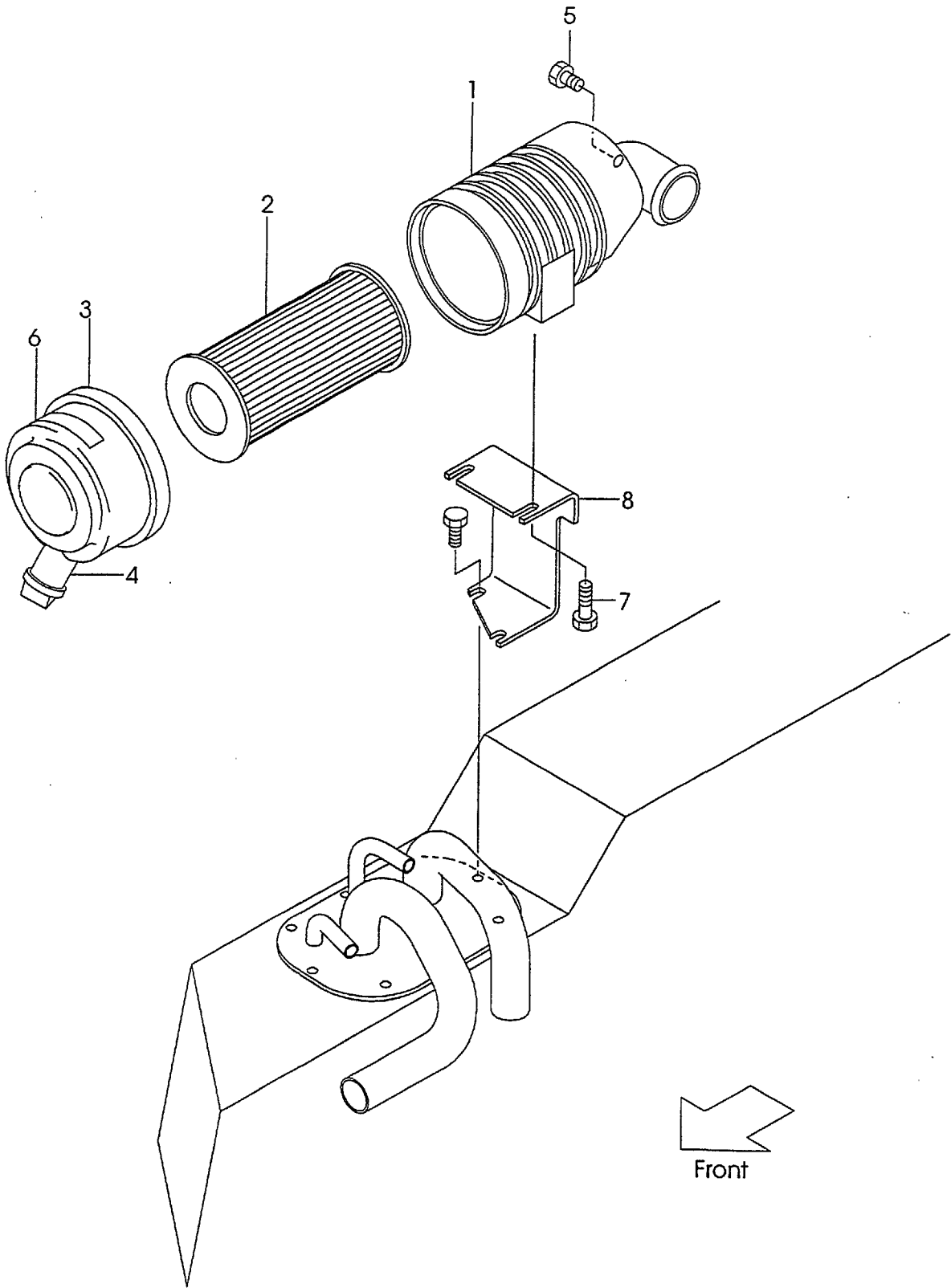

A:FG20C6H D:FG25T6H G:FD25C6H
B:FG20T6H E:FD20C6H H:FD25T6H
C:FG25C6H F:FD20T6H

Fig.3
(F5H21040)

Item No	Part No.	Mark	Description	Req'd	Remarks : Serial No.
A1	234A1-00101		CLEANER-ASSY,AIR	1	E,F,G,H INC.1-6
1	234A1-00111		BODY	1	E,F,G,H
2	256G1-08011		ELEMENT	1	E,F,G,H
3	256G1-08021		COVER	1	E,F,G,H
4	256A1-08031		VALVE,VACUATOR	1	E,F,G,H
5	53651-12551		CAP,NIPPLE	1	E,F,G,H
6	234A1-00121		LABEL	1	E,F,G,H
7	01183-08016		BOLT	2	E,F,G,H
8	239A1-02511		BRACKET,AIR-CLEANER	1	E,F,G,H

Fig.4 AIR DUCT(G-TYPE)
(F5H21050)

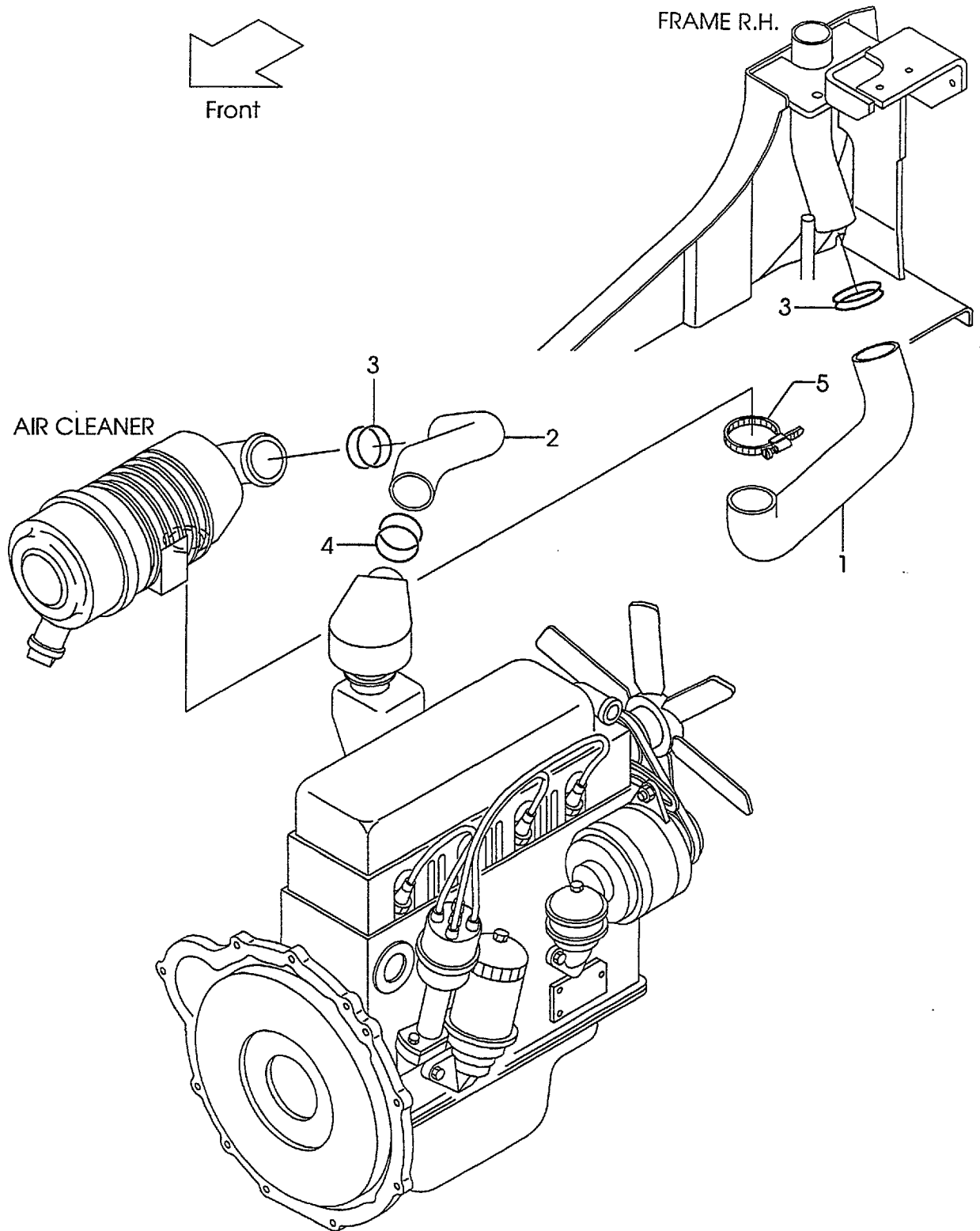

A:FG20C6H D:FG25T6H G:FD25C6H
B:FG20T6H E:FD20C6H H:FD25T6H
C:FG25C6H F:FD20T6H

Fig.4
(F5H21050)

Item No	Part No.	Mark	Description	Req'd	Remarks : Serial No.
1	218G1-02101		HOSE	1	A,B,C,D
2	233A1-02001		HOSE	1	A,B,C,D
3	04911-00060		CLIP	2	A,B,C,D
4	04911-00065		CLIP	1	A,B,C,D
5	224W4-52071		BAND	1	A,B,C,D

Fig.5 AIR DUCT(D-TYPE)
(F5H21080)

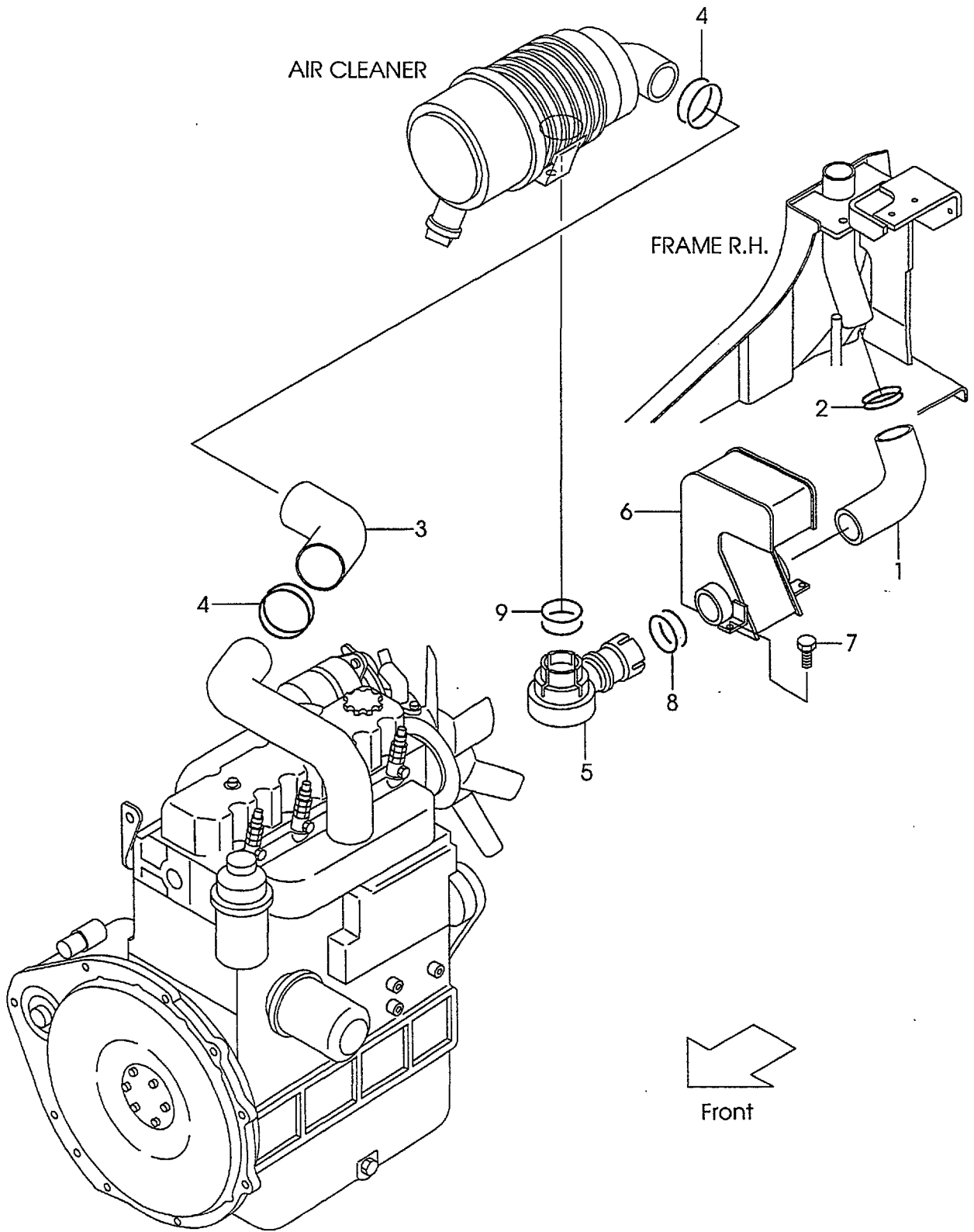

A:FG20C6H D:FG25T6H G:FD25C6H
B:FG20T6H E:FD20C6H H:FD25T6H
C:FG25C6H F:FD20T6H

Fig.5
(F5H21080)

Item No	Part No.	Mark	Description	Req'd	Remarks : Serial No.
1	217M1-02031		HOSE	1	E,F,G,H
2	04911-00060		CLIP	1	E,F,G,H
3	239A1-02501		HOSE	1	E,F,G,H
4	04911-00075		CLIP	2	E,F,G,H
5	234A1-02001		DUCT	1	E,F,G,H
6	217M1-02402		RESONATOR	1	E,F,G,H
7	01185-08016		BOLT	2	E,F,G,H
8	04911-00055		CLIP	1	E,F,G,H
9	04911-00070		CLIP	1	E,F,G,H

Fig.6 COOLING UNIT(G-TYPE)
(F5H22110)

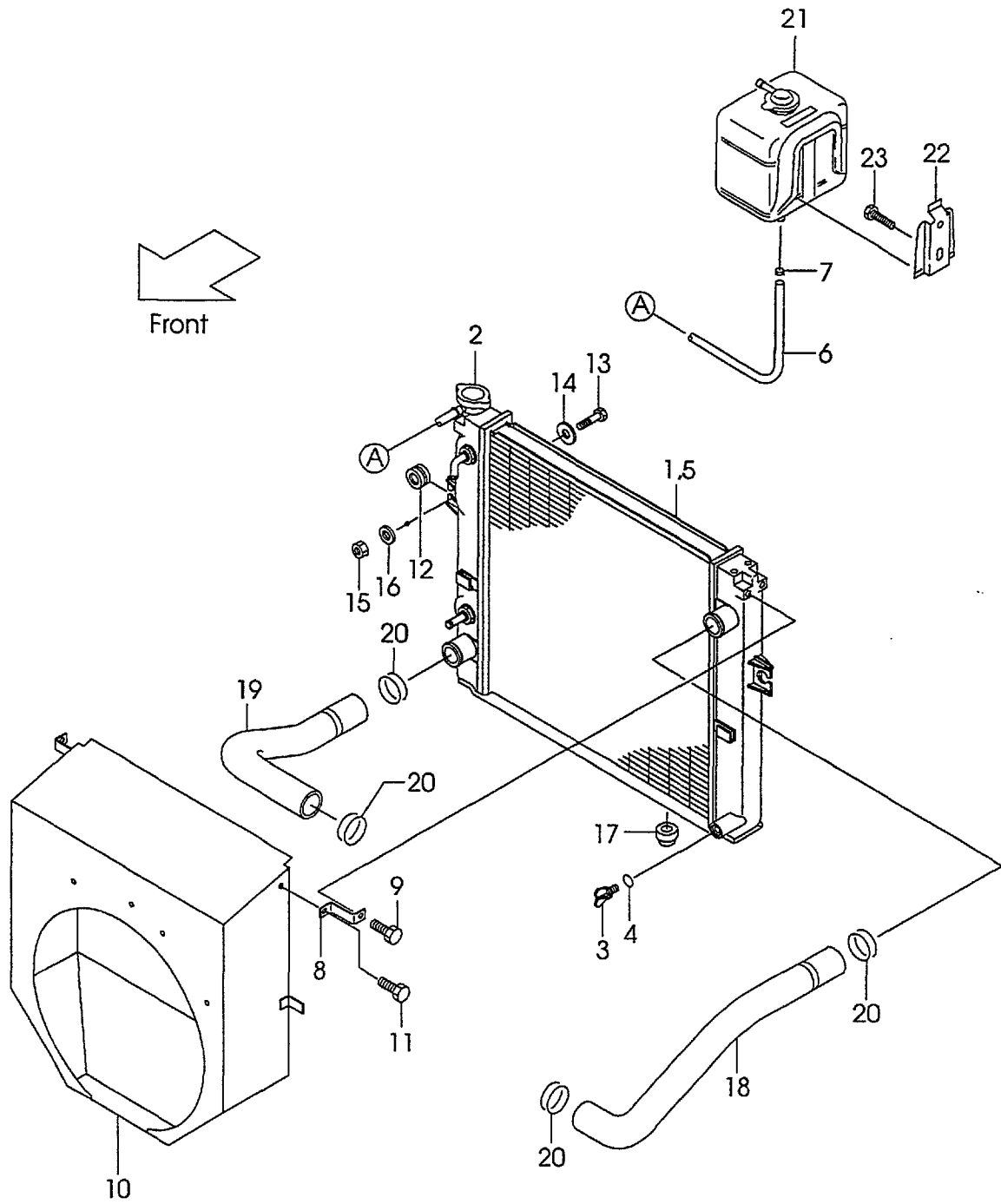

A:FG20C6H D:FG25T6H G:FD25C6H
 B:FG20T6H E:FD20C6H H:FD25T6H
 C:FG25C6H F:FD20T6H

Fig.6
 (F5H22110)

Item No	Part No.	Mark	Description	Req'd	Remarks : Serial No.
A1	237A2-10101		RADIATOR-ASSY	1	A,C INC.1-7
-	237B2-10101		RADIATOR-ASSY	1	B,D INC.1-7
1	NO PART NO.	#	BODY	1	A,B,C,D
2	222A2-10211		CAP	1	A,B,C,D
3	234A2-12201		COOK	1	A,B,C,D
4	234A2-12211		O-RING	1	A,B,C,D
5	NO PART NO.	#	NUT	3	A,B,C,D
6	218M2-12301		HOSE	1	A,B,C,D
7	23772-12071		CLIP	1	A,B,C,D
8	239B2-12141		BRACKET	1	B,D
9	01185-08016		BOLT	1	B,D
10	237A2-12201		SHRAUD	1	A,B,C,D
11	01185-08016		BOLT	2	A,B,C,D
12	214A2-12001		RUBBER	2	A,B,C,D
13	214A2-12021		BOLT	2	A,B,C,D
14	22252-32251		WASHER	2	A,B,C,D
15	23652-12051		NUT	2	A,B,C,D
16	02000-00010		WASHER	2	A,B,C,D
17	214A2-12011		RUBBER	2	A,B,C,D
18	237A2-12001		HOSE,UPPER	1	A,B,C,D
19	237A2-12011		HOSE,LOWER	1	A,B,C,D
20	04911-00044		CLIP	4	A,B,C,D
21	214A2-12111		TANK,RESERVE	1	A,B,C,D
22	214A2-12141		BRACKET	1	A,B,C,D
23	214A2-42611		SCREW	2	A,B,C,D

Fig.7 COOLING UNIT(D-TYPE)
(F5H22120)

