

ご使用のまえに

このパーツマニュアルは、**TCM** の構成部品を収録しています。

部品ご注文について

部品ご注文の際は、必ず車両の形式・仕様・製造番号（号車）、部品番号および注文数を明示してください。車両の製造番号（号車）は車両銘板に表示しています。

製造番号（号車）

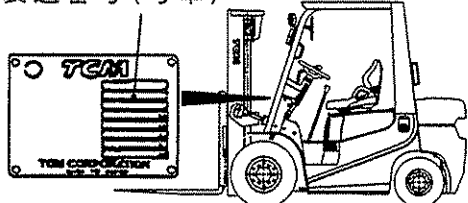

部品は、必ず「**TCM** 純正部品」をご使用ください。
純正部品以外の部品をご使用になり、故障が発生した場合は保証できません。

ご使用について

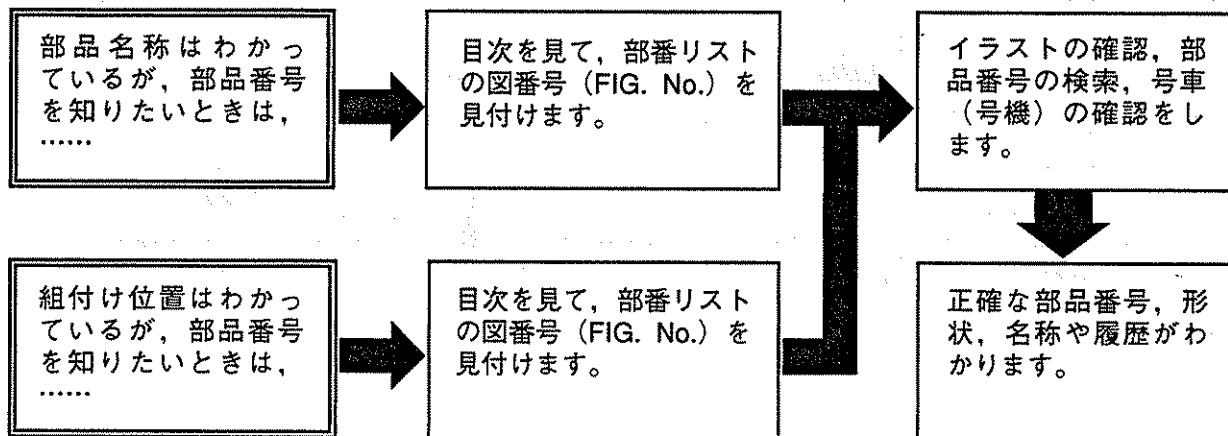

略語および記号

- ASSY 組立品を示します。
- RH 車両の前方向に向かって右側を示します。
- LH 車両の前方向に向かって左側を示します。
- AR 必要に応じた数を使用します。
- * セットおよびキットの販売部品を示します。
- T 厚みを示します。
- 十 図示していません。
- # 単体販売しません。

部品は、品質向上のため予告なく変更することがありますので、あらかじめご了承ください。詳細は、**TCM** 指定整備工場にご相談ください。

INTRODUCTION

This Parts Manual contains the component parts of the **TCM FORKLIFT TRUCK**.

How to order parts

When ordering, be sure to specify the model name, specification and serial number (machine number) of your machine, as well as the part number and desired quantity for each part. The machine serial number (machine number) is indicated on the machine name plate.

Serial number
(machine number)

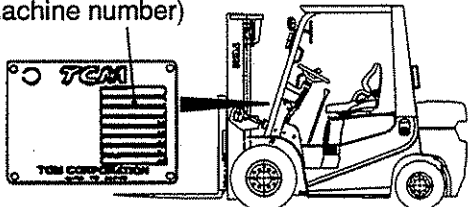

Always use "**TCM's** Genuine Parts". We cannot guarantee any loss or trouble attributable to other parts than ours.

How to use the Parts Manual

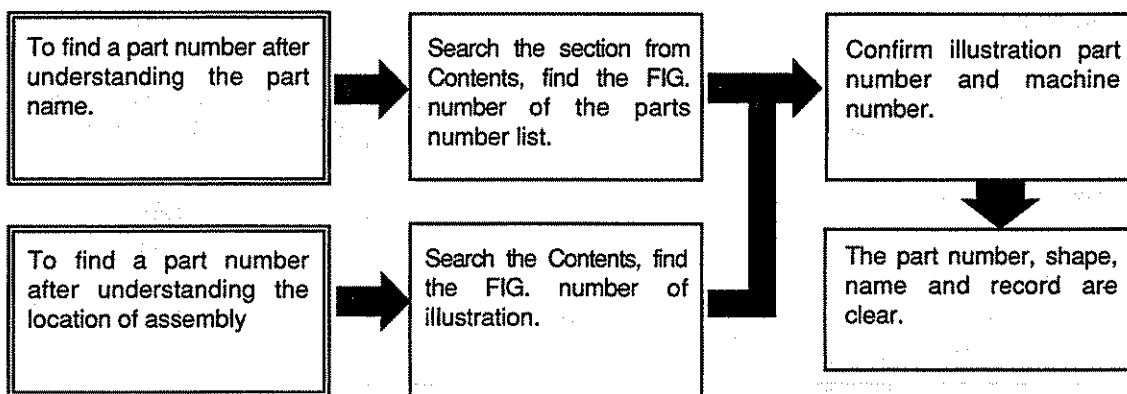

Abbreviations and symbols

ASSY ...	Assembled unit.
RH	Right-hand when viewed forward on the truck.
LH	Left-hand when viewed forward on the truck.
AR	Quantity required.
*	The marketable part set or kit.
T	Thickness.
+	Not illustrated.
#	Not sold separately.

Materials and specifications subject to change without notice.

CONTENTS

CHASSIS

a	FG15C9H	e	FD15C9H
b	FG15T9H	f	FD15T9H
c	FG18C9H	g	FD18C9H
d	FG18T9H	h	FD18T9H

SECTION	a	b	c	d	e	f	g	h	FIG. NO.
HUB NUT	○	○	○	○	○	○	○	○	44
FRONT WHEEL	○	○			○	○			45
FRONT WHEEL			○	○			○	○	46
REAR WHEEL	○	○	○	○	○	○	○	○	47
POWER CYLINDER	○	○	○	○	○	○	○	○	48
POWER CYLINDER [OBT][EXC]	○	○	○	○	○	○	○	○	49
OVERHEAD GUARD	○	○	○	○	○	○	○	○	50
FRONT PIPE	○	○	○	○	○	○	○	○	51
REAR PIPE	○	○	○	○	○	○	○	○	52
REAR PIPE [EXB][EXC]	○	○	○	○	○	○	○	○	53
HEAD GUARD PARTS	○	○	○	○	○	○	○	○	54
ACCEL PEDAL (G-TYPE)	○	○	○	○					55
ACCEL PEDAL (D-TYPE)					○	○	○	○	56
FOOT PEDAL (C-TYPE)	○		○		○		○		57
FOOT PEDAL (T-TYPE)		○		○		○		○	58
FOOT PEDAL CYLINDER (C-TYPE)	○		○		○		○		59
FOOT PEDAL CYLINDER (T-TYPE)		○		○		○		○	60
BRAKE PIPE (C-TYPE)	○		○		○		○		61
BRAKE PIPE (T-TYPE)		○		○		○		○	62
FOOT PEDAL COVER	○	○	○	○	○	○	○	○	63
BRAKE LEVER	○	○	○	○	○	○	○	○	64
FRAME	○	○	○	○	○	○	○	○	65
OIL TANK	○	○	○	○	○	○	○	○	66
OIL CAP & LEVEL	○	○	○	○	○	○	○	○	67
FUEL TANK (G-TYPE)	○	○	○	○					68
FUEL TANK (D-TYPE)					○	○	○	○	69
BALANCE WEIGHT	○	○	○	○	○	○	○	○	70
FRONT GUARD	○	○	○	○	○	○	○	○	71
BONNET	○	○	○	○	○	○	○	○	72
RADIATOR COVER	○	○	○	○	○	○	○	○	73
FLOOR BOARD	○	○	○	○	○	○	○	○	74
SEAT	○	○	○	○	○	○	○	○	75
PUMP UNIT (G-TYPE)	○	○	○	○					76
PUMP UNIT (D-TYPE)					○	○	○	○	77
CONTROL VALVE [2SV]	○	○	○	○	○	○	○	○	78
INLET SECTION	○	○	○	○	○	○	○	○	79
SPOOL SECTION (LIFT)	○	○	○	○	○	○	○	○	80
SPOOL SECTION (TILT)	○	○	○	○	○	○	○	○	81
CONTROL VALVE FITTING	○	○	○	○	○	○	○	○	82
VALVE CONTROL [2SV]	○	○	○	○	○	○	○	○	83
VALVE CONTROL KNOB	○	○	○	○	○	○	○	○	84
HYDRAULIC LINE (MAIN)(1/3)(G-TYPE)	○	○	○	○					85
HYDRAULIC LINE (MAIN)(1/3)(D-TYPE)					○	○	○	○	86

MEMO



Fig.1 ENGINE MOUNT (G-TYPE)
(F5H11010)

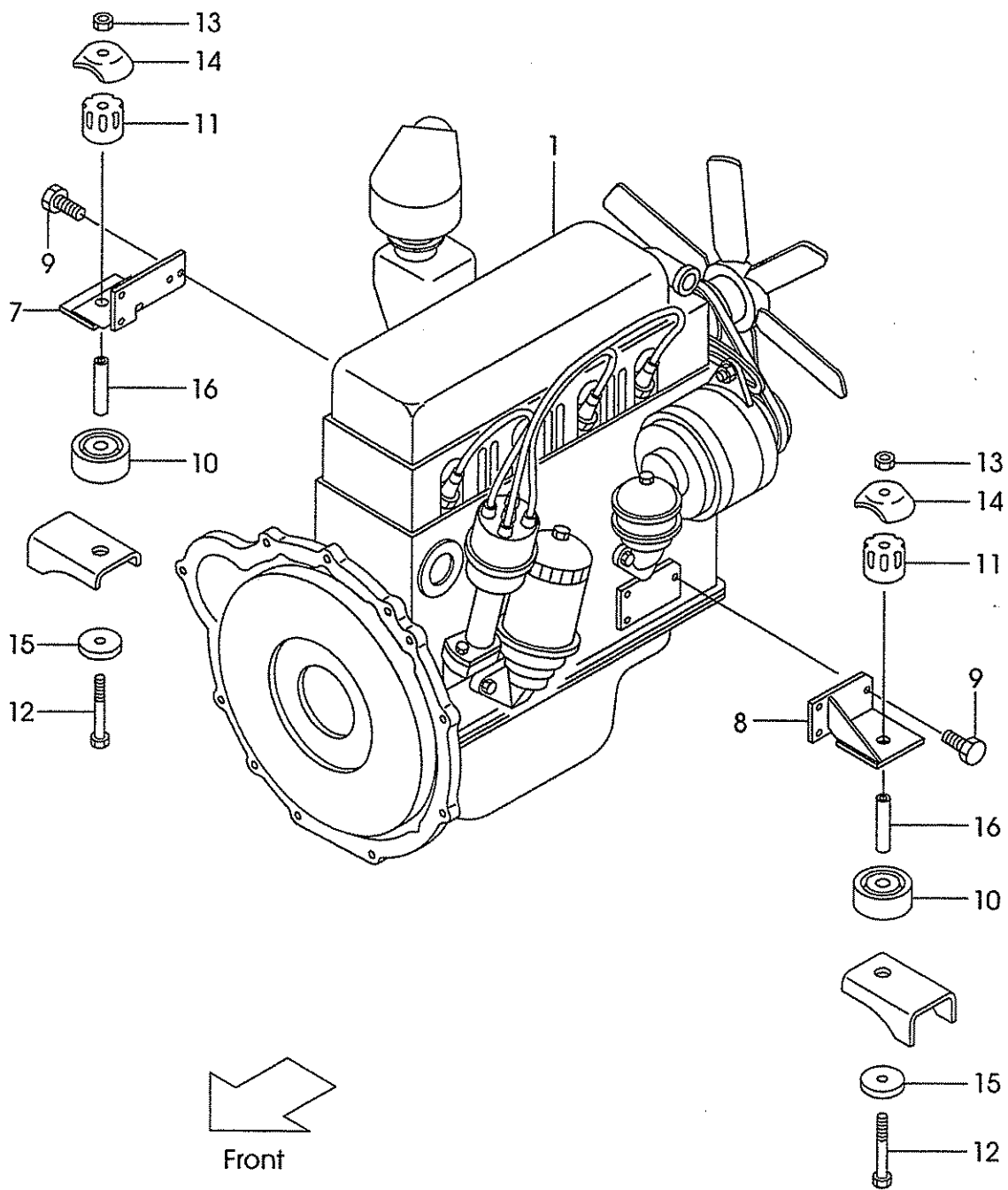

A:FG15C9H FG15T9H FG18C9H FG18T9H

Item No	Part No.	Mark	Description	Req'd	Remarks : Serial No.
1	236F1-00101		ENGINE,H20	1	
2	01400-00008	+	NUT	2	
3	02010-00008	+	WASHER	2	
4	02000-00008	+	WASHER	2	
5	01100-05010	+	BOLT	1	
6	02010-00005	+	WASHER	1	
7	218G1-02351		BRACKET,ENGINE,RH	1	
8	218G1-02301		BRACKET,ENGINE,LH	1	
9	01218-10025		BOLT	7	
10	216G1-02111		RUBBER,CUSHION	2	
11	214A1-02111		RUBBER,CUSHION	2	
12	01103-10100		BOLT	2	
13	23651-02011		NUT	2	
14	214A1-02121		CAP	2	
15	23651-02001		PLATE	2	
16	234A1-02071		COLLAR	2	

Fig.2 ENGINE MOUNT (D-TYPE)

(F5H11020)

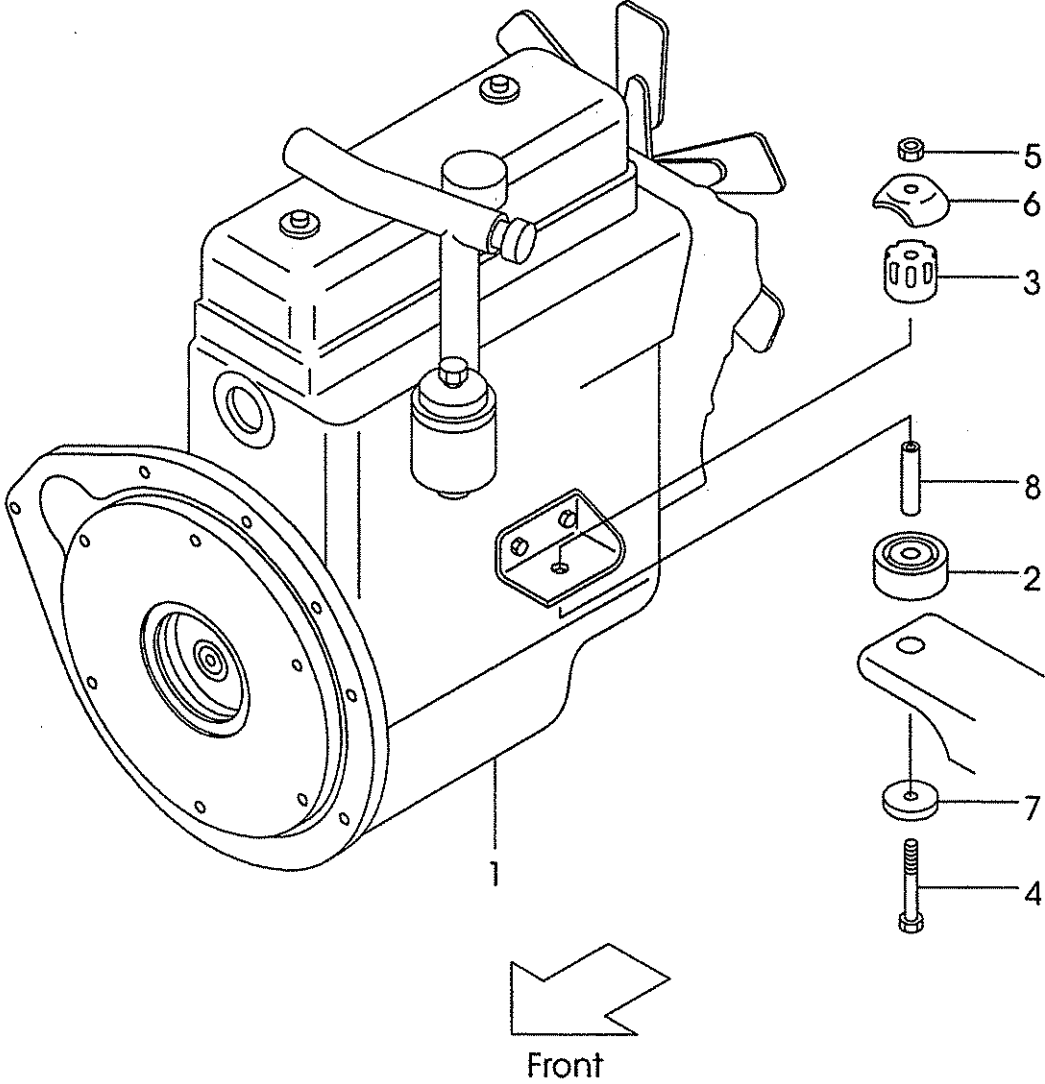

Fig.2
(F5H11020)

A:FD15C9H FD15T9H FD18C9H FD18T9H

Item No	Part No.	Mark	Description	Req'd	Remarks : Serial No.
1	238F1-00101		ENGINE,C240	1	
2	216G1-02111		RUBBER,CUSHION	2	
3	214A1-02111		RUBBER,CUSHION	2	
4	01103-10100		BOLT	2	
5	23651-02011		NUT	2	
6	214A1-02121		CAP	2	
7	23651-02001		PLATE	2	
8	234A1-02071		COLLAR	2	

Fig.3 AIR CLEANER (G-TYPE)
(F5H11030)

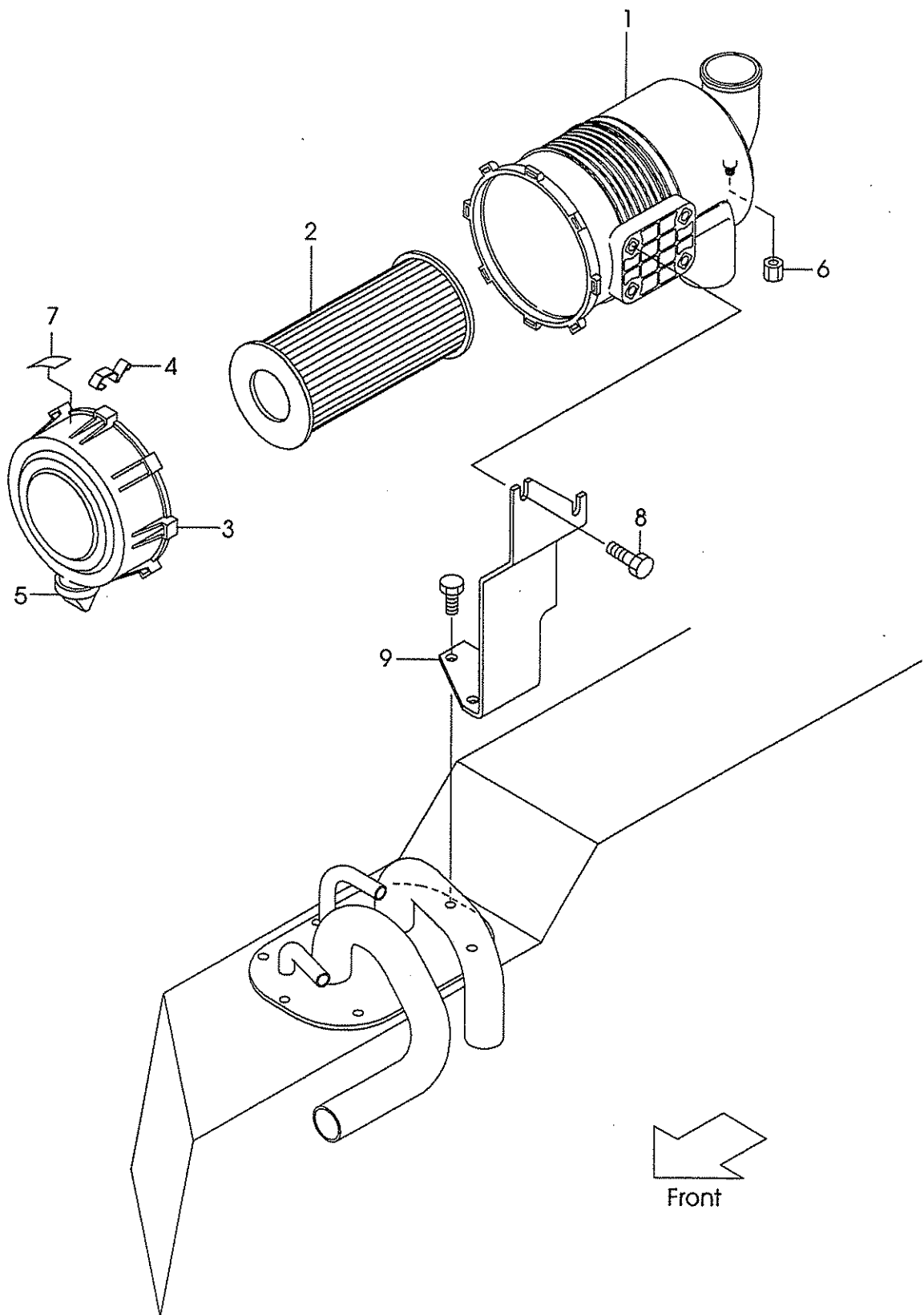

Fig.3
(F5H11030)

A:FG15C9H FG15T9H FG18C9H FG18T9H

Item No	Part No.	Mark	Description	Req'd	Remarks : Serial No.
A1	216G1-02451		CLEANER-ASSY,AIR	1	INC.1-7
1	216G1-02481		BODY	1	
2	256C1-08011 ✓		ELEMENT,AIR	1	
3	216G1-02461		COVER	1	
4	216G1-02471		LATCH	3	
5	216G1-02491		VALVE,VACUATOR	1	
6	53651-12551		CAP,NIPPLE	1	
7	216G1-02501		LABEL	1	
8	01183-08016		BOLT	4	
9	237A1-02101		BRACKET,AIR-CLEANER	1	

Fig.4 AIR CLEANER (D-TYPE)
(F5H11040)

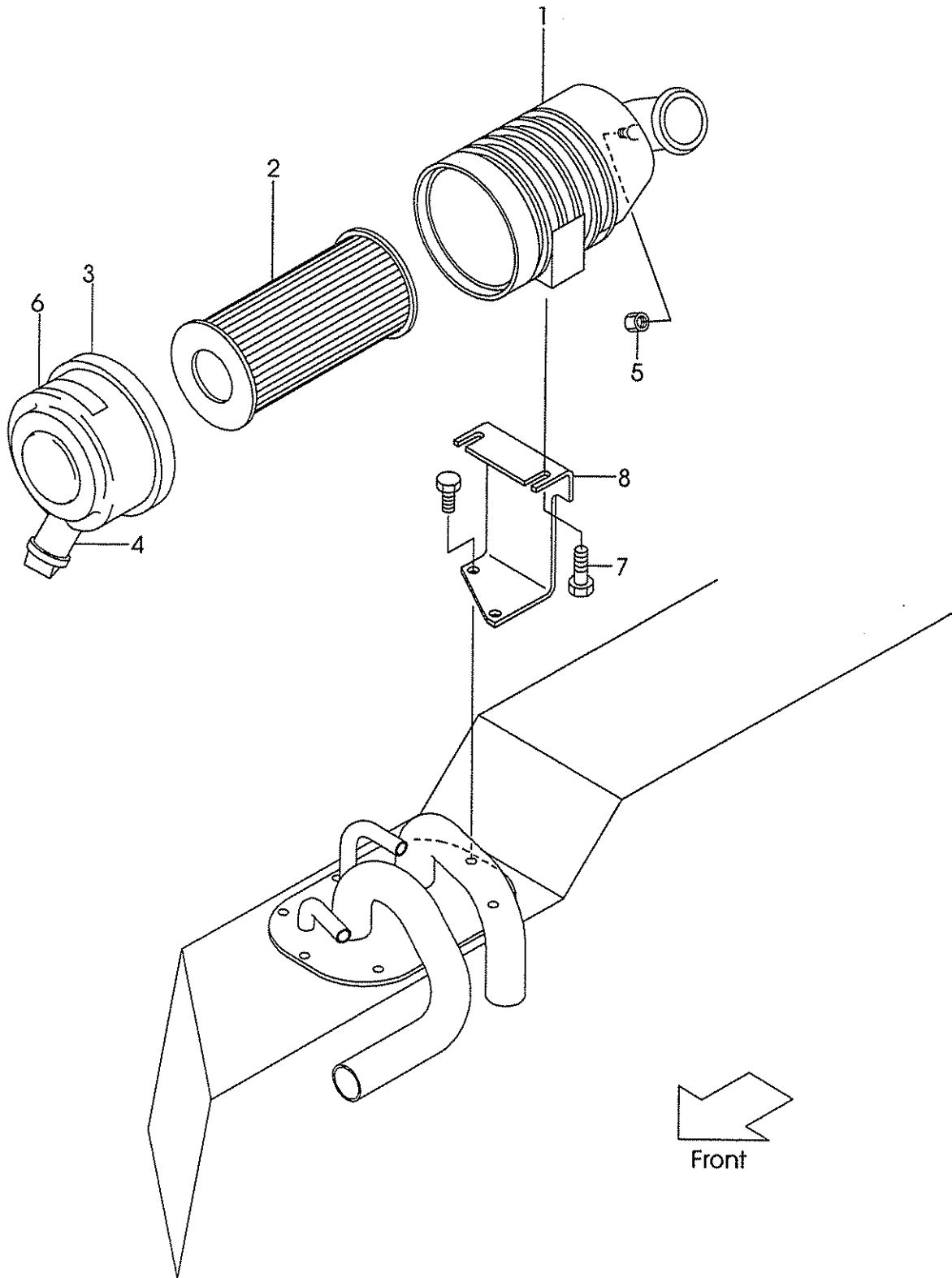

Fig.4
(F5H11040)

A:FD15C9H FD15T9H FD18C9H FD18T9H

Item No	Part No.	Mark	Description	Req'd	Remarks : Serial No.
A1	216G1-02051		CLEANER-ASSY,AIR	1	INC.1-6
1	216G1-02301		BODY	1	
2	256C1-08011 ✓		ELEMENT,AIR	1	
3	228F1-02211		COVER	1	
4	256A1-08031		VALVE,VACUATOR	1	
5	53651-12551		CAP,NIPPLE	1	
6	216G1-02311		LABEL	1	
7	01183-08016		BOLT	2	
8	219M1-02101		BRACKET,AIR-CLEANER	1	

Fig.5 AIR DUCT (G-TYPE)
(F5H11050)

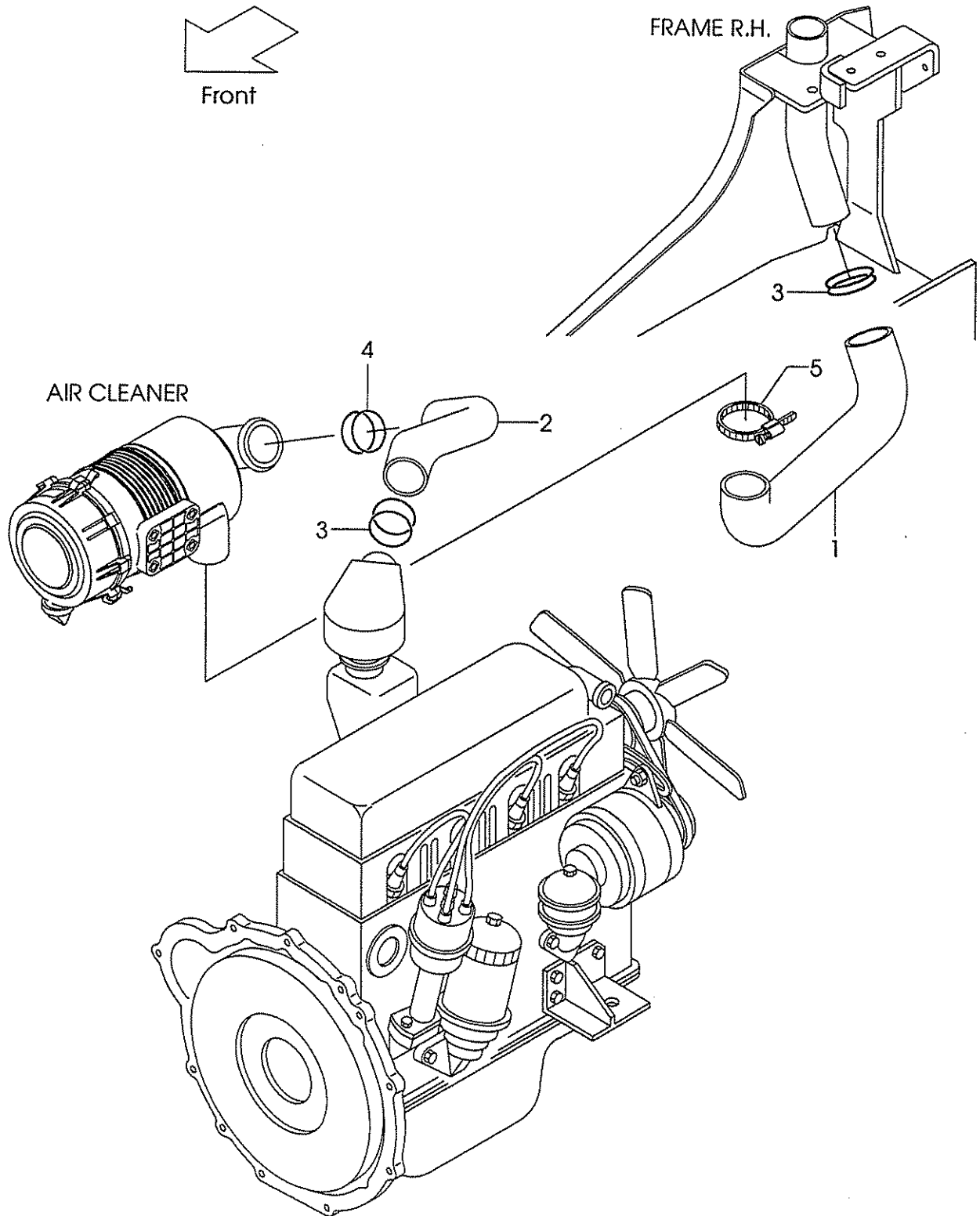
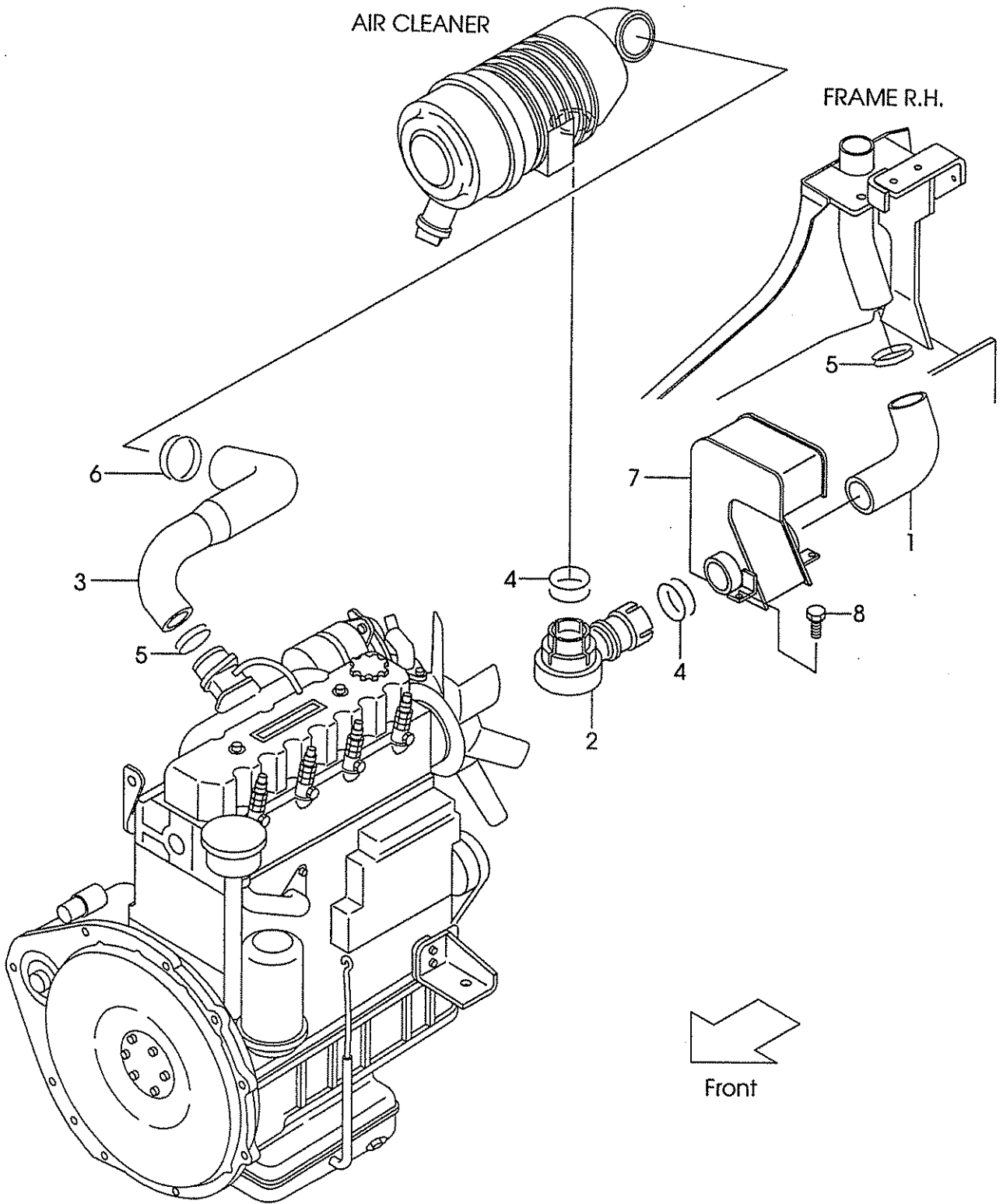

Fig.5
(F5H11050)

A:FG15C9H FG15T9H FG18C9H FG18T9H

Item No	Part No.	Mark	Description	Req'd	Remarks : Serial No.
1	218G1-02101		HOSE,AIR-DUCT	1	
2	216G1-02011		HOSE,AIR-INTAKE	1	
3	04911-00060		CLIP	2	
4	04911-00065		CLIP	1	
5	224W4-52071		BAND	1	

Fig.6 AIR DUCT (D-TYPE)
(F5H11060)



A:FD15C9H FD15T9H FD18C9H FD18T9H

Item No	Part No.	Mark	Description	Req'd	Remarks : Serial No.
1	217M1-02031		HOSE,AIR-DUCT	1	
2	217M1-02011		INTAKE,AIR	1	
3	217M1-02001		HOSE,AIR-INTAKE	1	
4	04911-00055		CLIP	2	
5	04911-00060		CLIP	2	
6	04911-00065		CLIP	1	
7	217M1-02402		RESONATOR	1	
8	01185-08016		BOLT	2	

Fig.7 COOLING UNIT (G-TYPE)
(F5H12110)

