

COMPACT EXCAVATOR

# TB007

## WORKSHOP MANUAL

SERIAL NUMBER

TB007 : 1073001~

## **FOREWORD**

This manual is intended for persons who engage in maintenance operations, and explains procedures for disassembly and reassembly of the machine, check and maintenance procedures, maintenance reference values, troubleshooting and outline specifications, etc. Please use this manual as a reference in service activities to improve maintenance techniques.

Further, please be advised that items contained in this manual are subject to change without notice due to design modifications, etc.

### **MACHINE FRONT AND REAR, LEFT AND RIGHT**

The end where the dozer blade is mounted is the front and the end with the travel motors is the rear. Also the right and left sides of the operator when he is seated in the driver's seat are the right and left sides of the machine.

### **MACHINE SERIAL NUMBER**

The machine serial number is stamped on the identification plate. When sending reports and inquiries, and when ordering parts, etc., be sure to include this number.

### **MANUAL CONTROL**

Information on those to whom this manual is distributed is recorded in the ledger in the section in charge at this company, so please decide on a person to be in charge of it and control it. When there are updates or additions, etc., we will notify the person in charge.



## I . GENERAL



## II . SPECIFICATIONS



## III . MACHINE CONFIGURATION



## IV . HYDRAULIC UNITS



## V . TROUBLESHOOTING





## I . GENERAL



## FOREWORD

This section, GENERAL, summarizes the basic items which persons servicing the machine should be cautious about, and includes only those items which are essential for safe and correct operation. Please read this section thoroughly and apply it in maintenance operations. Further, since the contents of this manual may change due to future revisions, if you have any opinions or observations concerning this manual, please notify the person responsible.

**CONTENTS**

General Cautions ..... 3  
Cautions during Disassembly and Assembly ..... 4  
Cautions during Removal and Installation of the Hydraulic Units ..... 5  
Cautions during Removal and Installation of Piping ..... 6  
Handling of Seals ..... 7  
Tightening Torques ..... 8



## GENERAL CAUTIONS

1. Wear a helmet, safety shoes and work clothes.
2. Be sure to check equipment and tools, particularly equipment used for hoisting.
3. If more than one person is working together, decide the job and call sign and maintain good communications during operations.
4. Crane operation and hoisting should be done by persons with the proper qualifications.
5. Keep all persons from getting underneath a suspended load.
6. Before removing the installation bolts of heavy parts, support the parts by temporary hoisting a crane.

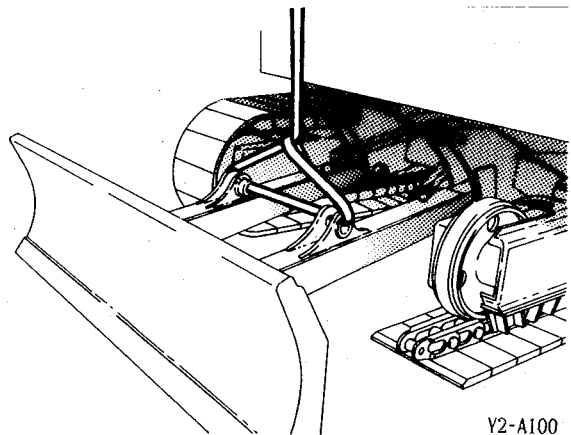

Y2-A100

7. If lifting a machine with a hoe attachment, etc. and going underneath it, be sure to support it with stands etc.

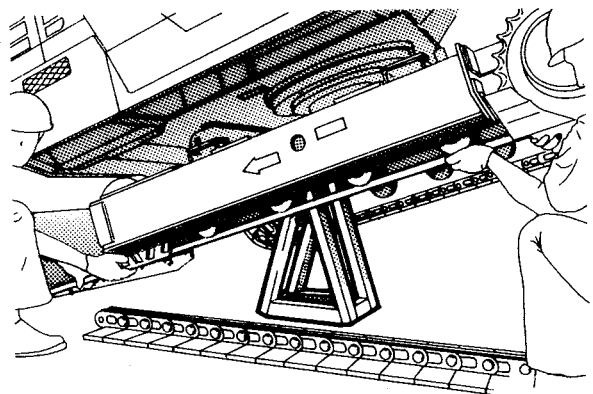

Y2-A101

8. When repairing the electrical system, disconnect the cables from the battery before beginning the operation.
9. When welding the machine, disconnect the battery first.
10. Maintain the standard tightening torques for piping and bolts, etc.
11. After completing repairs, run the engine at low speed, and conduct trial operation after filling it full with operating oil.

## GENERAL

---

### CAUTIONS DURING DISASSEMBLY AND ASSEMBLY

1. Clean the machine before disassembly operation.
2. Before disassembly, check the machine conditions and record them.
  - Model, Machine Serial Number, Hourmeter
  - Reason for Repairs, Repairs History
  - Dirtiness of Filters
  - Fuel and Oil Conditions
  - Damage to each parts, etc.
3. To make reassembly operations easy, make matching marks at the necessary points.
4. Clean all disassembled parts and new parts, then arrange them in the proper sequence.
5. Be sure to replace all seals and cotter pins, etc. with new parts.
6. Keep parts which should not come in contact with oil and water separate from parts with oil on them.
  - Electrical Parts, Rubber, V-Belts, etc.
7. When installing bearings, bushings and oil seals, as a rule, use a press. When a hammer, etc. is used, it leaves bruises.
8. Wipe all joining surfaces clean so that there is no dirt or dust adhering to them.
9. Wrap seal tape from the front end, Wrapping it tight and leaving 1 or 2 threads bare, Overlap the tape by about 10mm.

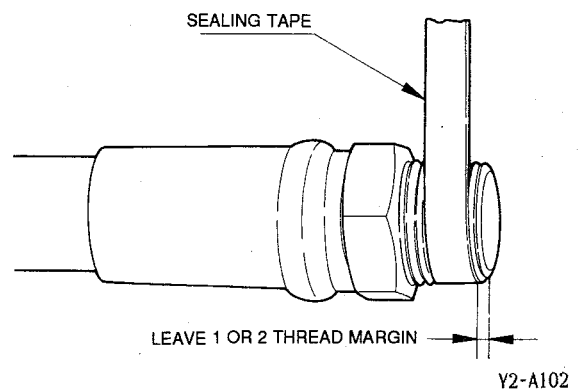

### CAUTIONS DURING REMOVAL AND INSTALLATION OF THE HYDRAULIC UNITS

1. Make sure that the hydraulic oil's temperature has dropped.
2. To prevent a loss of flow of the hydraulic oil, the residual pressure in the piping and the internal pressure in the hydraulic oil tank should be bled out.
3. Be sure to install caps or plugs on all openings in the hydraulic unit to prevent dirt from getting into the unit through the openings.

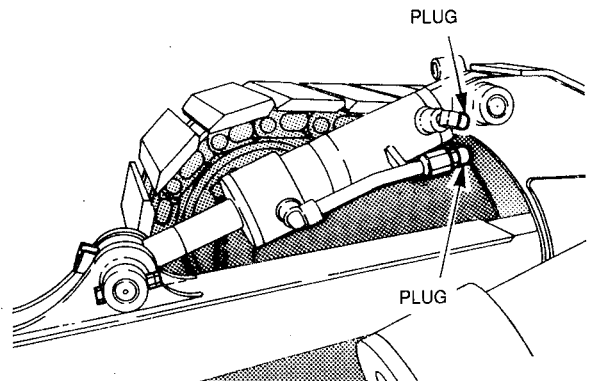

Y2-A103

4. It is easy to mistake hydraulic oil adhering to the hydraulic unit for an oil leak, so wipe the unit off thoroughly.
5. Be sure that no damage is done to the plating on the rod in the hydraulic cylinder.
6. As a rule, removal and installation of the hydraulic cylinder should be done with the rod fully retracted.
7. When removing and installing the hydraulic cylinder, be sure to bleed out the air. (See the item in "IV. Hydraulic Units, Cylinder" .)
8. After installation of the hydraulic unit, be sure to pressurize the hydraulic oil tank. If this operation is forgotten, it could cause cavitation of the hydraulic pump. Also, it could have a drastic effect on the life of the hydraulic pump.
  - Hydraulic tank pressurization method:  
Lower the dozer blade until it comes in contact with the ground. Extend all the cylinders fully except the dozer blade cylinder. In this state, tighten the air vent plug to seal the tank tight.

TANK PRESSURIZATION POSTURE

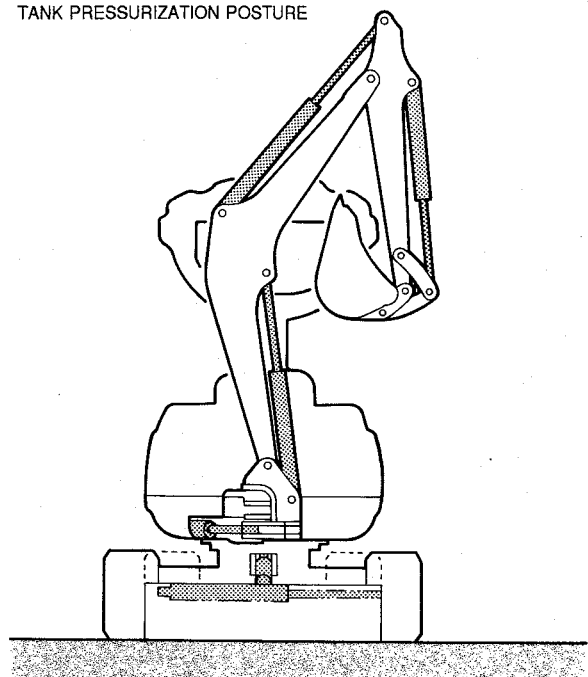

Y2-063

## GENERAL

---

### CAUTIONS DURING REMOVAL AND INSTALLATION OF PIPING

1. When hydraulic hoses are installed, tighten them once to the prescribed torque, then loosen them slightly and retighten them to the prescribed torque.
  - Tighten the fittings after the installation surfaces fit snugly together.
  - Pieces wrapped with seal tape are excluded.
2. Use 2 spanners, each on an opposite side, to remove and tighten fittings so that the hoses or steel pipes are not twisted.

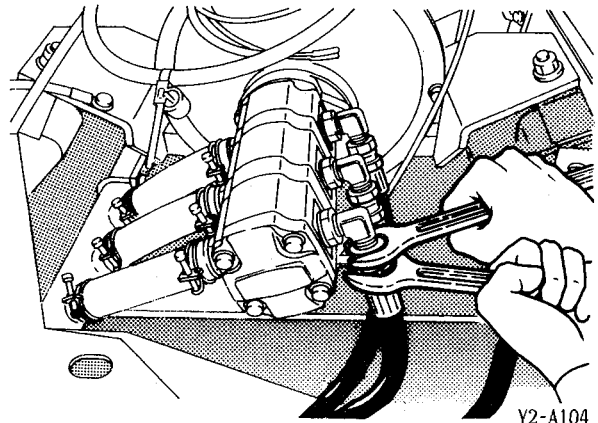

Y2-A104

3. After installation of hydraulic hoses or steel pipes, apply the maximum working pressure 5 or 6 times and confirm that there is no leakage.

## HANDLING OF SEALS

1. Clean the grooves for O-rings and if there is any ridge, etc, remove it.

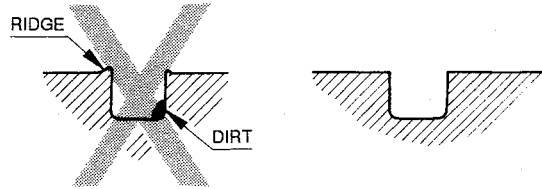

Y2-A105

2. Be careful not to twist O-rings. If an O-ring is twisted, remove the twist with the fingertips.
3. During insertion, be careful not to damage the seal.
4. Handling of Floating Seals
  - Wipe all oil off the O-ring and housing of the floating seal.
  - When assembling, apply a thin coating of gear oil to the contact surface of the housing.
  - After assembly, turn the seal 2 or 3 times to get it to fit snugly.
5. Apply grease to the lip of the oil seal.
  - This is to prevent wear when it is first started up after assembly.

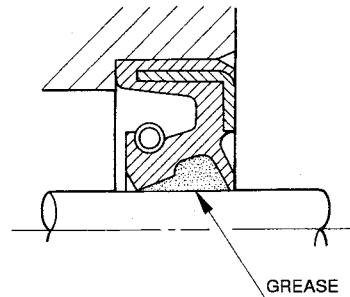

Y2-A106

# GENERAL

## TIGHTENING TORQUES

### Hydraulic Hoses

Hose Fitting Size	Torque			
	Union Nut (PF)		Taper Thread (PT)	
	kgf·m	ft-lb	kgf·m	ft-lb
1/8	1.0 <sup>+0.5</sup> <sub>0</sub>	7.3 <sup>+3.5</sup> <sub>0</sub>	1.2 <sup>±0.12</sup>	8.7 <sup>±0.8</sup>
1/4	2.5 <sup>+0.5</sup> <sub>0</sub>	18.1 <sup>+3.5</sup> <sub>0</sub>	3.0 <sup>±0.30</sup>	21.7 <sup>±2.1</sup>
3/8	5.0 <sup>+0.5</sup> <sub>0</sub>	36.2 <sup>+3.5</sup> <sub>0</sub>	5.5 <sup>±0.55</sup>	39.8 <sup>±3.9</sup>
1/2	6.0 <sup>+0.5</sup> <sub>0</sub>	43.4 <sup>+3.5</sup> <sub>0</sub>	9.0 <sup>±0.90</sup>	65.1 <sup>±6.4</sup>
3/4	12.0 <sup>+0.5</sup> <sub>0</sub>	86.8 <sup>+3.5</sup> <sub>0</sub>	15.0 <sup>±1.50</sup>	108.5 <sup>±10.7</sup>
1	14.0 <sup>+0.5</sup> <sub>0</sub>	101.3 <sup>+3.5</sup> <sub>0</sub>	20.0 <sup>±2.00</sup>	144.7 <sup>±14.3</sup>

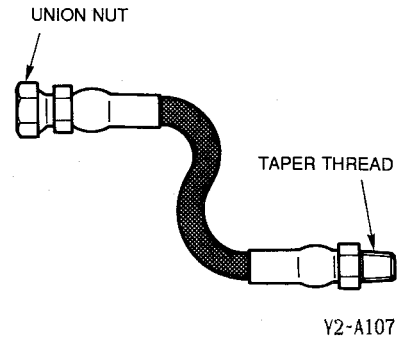

### Bite Type Pipe Fitting for Steel Pipe

Pipe Outer Diameter (mm)	Torque	
	kgf·m	ft-lb
8	3.5 <sup>±0.5</sup>	25.3 <sup>±3.5</sup>
10	4.25 <sup>±0.25</sup>	30.7 <sup>±1.7</sup>
12	6.0 <sup>±0.5</sup>	43.4 <sup>±3.5</sup>
15	9.0 <sup>±0.5</sup>	65.1 <sup>±3.5</sup>
16	9.5 <sup>±0.5</sup>	68.7 <sup>±3.5</sup>
18	13.5 <sup>±0.5</sup>	97.6 <sup>±3.5</sup>
22	21.0 <sup>±1.0</sup>	151.8 <sup>±7.2</sup>
27.2	25.0 <sup>±1.0</sup>	181.0 <sup>±7.2</sup>
28	32.0 <sup>±2.0</sup>	231.4 <sup>±14.3</sup>
32	32.0 <sup>±2.0</sup>	231.4 <sup>±14.3</sup>
35	42.0 <sup>±2.0</sup>	303.7 <sup>±14.3</sup>

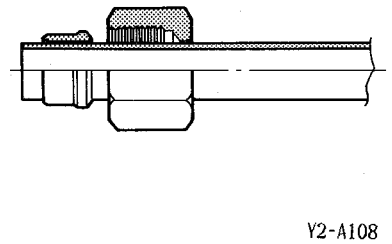

Joints for Piping

Thread Nominal Diameter (PT)	Torque			
	Steel		Cast Steel	
	kgf·m	ft-lb	kgf·m	ft-lb
1/8	1.2 <sup>±0.12</sup>	8.7 <sup>±0.8</sup>	1.1 <sup>±0.11</sup>	8.0 <sup>±0.7</sup>
1/4	3.0 <sup>±0.30</sup>	21.7 <sup>±2.1</sup>	2.5 <sup>±0.25</sup>	18.1 <sup>±1.7</sup>
3/8	5.5 <sup>±0.55</sup>	39.8 <sup>±3.9</sup>	5.0 <sup>±0.50</sup>	36.2 <sup>±3.5</sup>
1/2	9.0 <sup>±0.90</sup>	65.1 <sup>±6.4</sup>	7.5 <sup>±0.75</sup>	54.3 <sup>±5.3</sup>
3/4	15.0 <sup>±1.50</sup>	108.5 <sup>±10.7</sup>	13.0 <sup>±1.30</sup>	94.1 <sup>±9.3</sup>
1	20.0 <sup>±2.00</sup>	144.7 <sup>±14.3</sup>	17.5 <sup>±1.75</sup>	126.6 <sup>±12.5</sup>

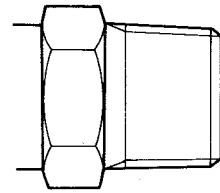

Y2-A109

Joints for Piping (O-ring Seal Type)

Thread Nominal Diameter (PT)	Torque	
	kgf·m	ft-lb
1/8	2.0 <sup>±0.2</sup>	14.5 <sup>±1.4</sup>
1/4	3.5 <sup>±0.5</sup>	25.3 <sup>±3.5</sup>
3/8	5.5 <sup>±0.5</sup>	39.8 <sup>±3.5</sup>
1/2	6.5 <sup>±0.5</sup>	47.0 <sup>±3.5</sup>
3/4	9.5 <sup>±0.5</sup>	68.7 <sup>±3.5</sup>
1	11.0 <sup>±1.0</sup>	79.5 <sup>±7.2</sup>
1-1/4	12.0 <sup>±1.0</sup>	86.8 <sup>±7.2</sup>
1-1/2	14.0 <sup>±1.0</sup>	101.2 <sup>±7.2</sup>

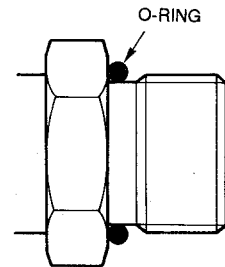

Y2-A110

Thread Nominal Diameter (UNF)	Torque	
	kgf·m	ft-lb
7/16-20	1.7 <sup>±0.2</sup>	12.3 <sup>±1.4</sup>
1/2-20	2.3 <sup>±0.2</sup>	16.6 <sup>±1.4</sup>
9/16-18	3.2 <sup>±0.3</sup>	23.1 <sup>±2.1</sup>
3/4-16	6.1 <sup>±0.5</sup>	44.1 <sup>±3.5</sup>
1-1/16-12	10.4 <sup>±0.6</sup>	75.2 <sup>±4.4</sup>
1-5/16-12	13.8 <sup>±0.8</sup>	99.8 <sup>±5.8</sup>
1-5/8-12	18.5 <sup>±1.0</sup>	133.8 <sup>±7.2</sup>

## GENERAL

### Bolts and Nuts (for ISO Strength Category 10.9)

Thread	Size × Pitch mm	Torque					
		General Tightening Points			Special Tightening Points		
		N-m	kgf-m	ft-lb	N-m	kgf-m	ft-lb
Coarse	M6 × 1.0	9.8 ±0.5	1.0 ±0.05	7.2 ±0.4	11.8 ±0.6	1.2 ±0.06	8.7 ±0.4
	M8 × 1.25	22.6 ±1.1	2.3 ±0.11	16.6 ±0.8	26.5 ±1.3	2.7 ±0.13	19.5 ±0.9
	M10 × 1.5	47.1 ±2.4	4.8 ±0.24	34.7 ±1.7	54.9 ±2.7	5.6 ±0.28	40.5 ±2.0
	M12 × 1.75	83.4 ±4.1	8.5 ±0.42	61.5 ±3.0	97.1 ±4.8	9.9 ±0.49	71.6 ±3.5
	M14 × 2.0	134.4 ±6.7	13.7 ±0.68	99.1 ±4.9	155.9 ±7.7	15.9 ±0.79	115.0 ±5.7
	M16 × 2.0	207.9 ±10.4	21.2 ±1.06	153.3 ±7.7	241.2 ±12.1	24.6 ±1.23	177.9 ±8.9
	M20 × 2.5	410.9 ±20.5	41.9 ±2.09	303.1 ±15.1	475.6 ±23.7	48.5 ±2.42	350.8 ±17.5
Fine	M8 × 1.0	24.5 ±1.2	2.5 ±0.12	18.1 ±0.9	28.4 ±1.4	2.9 ±0.14	21.0 ±1.0
	M10 × 1.25	50.0 ±2.5	5.1 ±0.25	36.9 ±1.8	58.8 ±2.9	6.0 ±0.30	43.4 ±2.2
	M12 × 1.5	87.3 ±4.3	8.9 ±0.44	64.4 ±3.2	102.0 ±5.1	10.4 ±0.52	75.2 ±3.8
	M14 × 1.5	135.3 ±6.8	13.8 ±0.69	99.8 ±5.0	157.9 ±7.8	16.1 ±0.80	116.5 ±5.8
	M16 × 1.5	220.6 ±11.0	22.5 ±1.12	162.7 ±8.1	256.0 ±12.7	26.1 ±1.30	188.8 ±9.4
	M20 × 1.5	452.1 ±22.6	46.1 ±2.30	333.4 ±16.6	524.7 ±26.1	53.5 ±2.66	387.0 ±19.2

1. General Tightening Points (Non-lubricated)
  - All securing points other than the special tightening points.
2. Special Tightening Points (Grease with molybdenum disulfide applied.)
  - Points where particularly necessary due to function.
  - a. Other parts where it is deemed particularly necessary due to the design.
3. Points where thread lock is used (Three Bond #1324 is applied.)
  - a. Connections between the slew bearing and lower frame.
  - b. Engine foot connections.
  - c. Pump coupling connections.
  - d. Counterweight tightening position.
  - e. Other parts where it is deemed particularly necessary due to the design.
4. If tightening torque values are provided in this manual, then tightening should be done according to those values.  
(This indicates that the tightening torque differs from the values given in this table.)
5. In order to tighten bolts and nuts evenly, they should be tightened alternately top, bottom, left, right.





## II. SPECIFICATIONS



## FOREWORD

This section, SPECIFICATIONS, includes brief specifications and maintenance standards for this machine, and is organized around the data required for service operations. Please use this manual in checks of the machine before servicing, checks after servicing and when replacing parts.

We want, through future revisions of this manual, to improve it and make it as complete as we possibly can. We welcome any opinions or suggestions, which you may have that would help us. Please address all comments to the person in charge.

### In regard to Standard Values and Allowable Values

The terms used in the items "Servicing Standards" and "Standards for Judging Performance" have the following meanings.

Standard Value ..... This indicates the standard value for the new machine at the time of shipping from the factory. It should be used as the target value for maintenance work after operation.

Allowable Value ..... The dimensions of parts change during use because of wear and deformation. Also, the performance of pumps, motors, and other hydraulic equipment drops, and this is the estimated value indicating the use limit for the respective part. It is decided under reference to the standard at the time of shipping, the results of various tests, etc. As the use conditions, the degree of repairs, etc. differ for each machine, these should be combined and used as reference for servicing standards and standards for judging performance.

\*Do not use the standard values and the allowable values as standards for customer claims.

# SPECIFICATIONS

---

## CONTENTS

Names of Components .....	3
Specification Diagrams .....	4
Lifting Capacities .....	5
Specification Tables .....	7
Weight Tables .....	10
Fluid Capacities .....	13
Recommended Lubricants .....	14
Types of Crawler Belts .....	15
Types of Attachments and Their Combinations .....	16
Servicing Standards .....	17
Standards for Judging Performance .....	25
Reference Value Table .....	25
Methods for Inspecting Performance .....	27