

# **Suzuki Swift Sport**

## **(RS416)**

### **2004-2008 Service/Repair Manual**



This Service Manual has been prepared with the latest service information available at the time of publication. It is subdivided into various group categories and each section contains diagnostic, disassembly, repair and installation procedures along with complete specifications and tightening references. Please read this manual carefully before proceeding, as incorrect service procedures may result in injury or death to service personnel or to the operator's of the vehicle.

# IMPORTANT

## WARNING/CAUTION/NOTE

Please read this manual and follow its instructions carefully. To emphasize special information, the words

**▲ WARNING**, **▲ CAUTION** and **NOTE** have special meanings. Pay special attention to the messages highlighted by these signal words.

### **▲ WARNING**

---

Indicates a potential hazard that could result in death or injury.

---

### **▲ CAUTION**

---

Indicates a potential hazard that could result in vehicle damage.

---

### **NOTE:**

---

Indicates special information to make maintenance easier or instructions clearer.

---

### **▲ WARNING**

---

This service manual is intended for authorized Suzuki dealers and qualified service technicians only. Inexperienced technicians or technicians without the proper tools and equipment may not be able to properly perform the services described in this manual.

Improper repair may result in injury to the technician and may render the vehicle unsafe for the driver and passengers.

---

### **▲ WARNING**

---

For vehicles equipped with a Supplemental Restraint (Air Bag) System:

- Service on and around the air bag system components or wiring must be performed only by an authorized SUZUKI dealer. Refer to “Air Bag System Components and Wiring Location View” under “General Description” in air bag system section in order to confirm whether you are performing service on or near the air bag system components or wiring. Please observe all WARNINGS and “Service Precautions” under “On-Vehicle Service” in air bag system section before performing service on or around the air bag system components or wiring. Failure to follow WARNINGS could result in unintentional activation of the system or could render the system inoperative. Either of these two conditions may result in severe injury.
  - If the air bag system and another vehicle system both need repair, Suzuki recommends that the air bag system be repaired first, to help avoid unintended air bag system activation.
  - Do not modify the steering wheel, instrument panel or any other air bag system component on or around air bag system components or wiring. Modifications can adversely affect air bag system performance and lead to injury.
  - If the vehicle will be exposed to temperatures over 93 °C (200 °F), for example, during a paint baking process, remove the air bag system components, that is air bag (inflator) modules, SDM and/or seat belt with pretensioner, beforehand to avoid component damage or unintended activation.
- 

The circle with a slash in this manual means “Don’t do this” or “Don’t let this happen”.

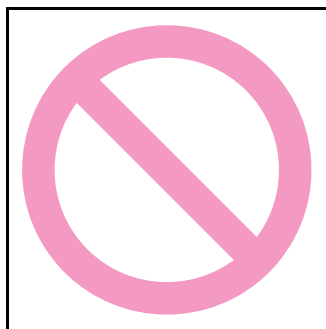



## FOREWORD

This manual (Volumes 1 and 2) contains procedures for diagnosis, maintenance, adjustments, minor service operations, replacement of components (Service) and for disassembly and reassembly of major components (Unit Repair-Overhaul).

**Applicable Model:**

**SWIFT (RS416) produced at KOSAI plant in Japan with the following vehicle identification numbers (VINS).**

**JSAEZC31S#####**

The contents are classified into sections each of which is given a section number as indicated in the Table of Contents on following page. And on the first page of each individual section is an index of that section.

This manual should be kept in a handy place for ready reference of the service work.

Strict observance of the so specified items will enable one to obtain the full performance of the vehicle.

When replacing parts or servicing by disassembling, it is recommended to use SUZUKI genuine parts, tools and service materials as specified in each description.

All information, illustrations and specifications contained in this literature are based on the latest product information available at the time of publication approval. And used as the main subject of description is the vehicle of standard specifications among others.

Therefore, note that illustrations may differ from the vehicle being actually serviced.

The right is reserved to make changes at any time without notice.

# TABLE OF CONTENTS

## Volume 1

## Volume 2

**Precautions**..... 00-i  
 Precautions ..... 00-1

**General Information** ..... 0-i  
 General Information ..... 0A-1  
 Maintenance and Lubrication ..... 0B-1

**Engine** ..... 1-i  
 Precautions ..... 1-1  
 Engine General Information and Diagnosis ..... 1A-1  
 Aux. Emission Control Devices ..... 1B-1  
 Engine Electrical Devices ..... 1C-1  
 Engine Mechanical ..... 1D-1  
 Engine Lubrication System ..... 1E-1  
 Engine Cooling System ..... 1F-1  
 Fuel System ..... 1G-1  
 Ignition System ..... 1H-1  
 Starting System ..... 1I-1  
 Charging System ..... 1J-1  
 Exhaust System ..... 1K-1

**Suspension** ..... 2-i  
 Precautions ..... 2-1  
 Suspension General Diagnosis ..... 2A-1  
 Front Suspension ..... 2B-1  
 Rear Suspension ..... 2C-1  
 Wheels and Tires ..... 2D-1

**Driveline / Axle** ..... 3-i  
 Precautions ..... 3-1  
 Drive Shaft / Axle ..... 3A-1

**Brakes** ..... 4-i  
 Precautions ..... 4-1  
 Brake Control System and Diagnosis ..... 4A-1  
 Front Brakes ..... 4B-1  
 Rear Brakes ..... 4C-1  
 Parking Brake ..... 4D-1  
 ABS ..... 4E-1  
 Electronic Stability Program ..... 4F-1

**Precautions**..... 00-i  
 Precautions ..... 00-1

**Transmission / Transaxle** ..... 5-i  
 Precautions ..... 5-1  
 Automatic Transmission/Transaxle ..... 5A-1  
 Manual Transmission/Transaxle ..... 5B-1  
 Clutch ..... 5C-1

**Steering** ..... 6-i  
 Precautions ..... 6-1  
 Steering General Diagnosis ..... 6A-1  
 Steering Wheel and Column ..... 6B-1  
 Power Assisted Steering System ..... 6C-1

**HVAC** ..... 7-i  
 Precautions ..... 7-1  
 Heater and Ventilation ..... 7A-1  
 Air Conditioning System ..... 7B-1

**Restraint** ..... 8-i  
 Precautions ..... 8-1  
 Seat Belts ..... 8A-1  
 Air Bag System ..... 8B-1

**Body, Cab and Accessories** ..... 9-i  
 Precautions ..... 9-1  
 Wiring Systems ..... 9A-1  
 Lighting Systems ..... 9B-1  
 Instrumentation / Driver Info. / Horn ..... 9C-1  
 Wipers / Washers ..... 9D-1  
 Glass / Windows / Mirrors ..... 9E-1  
 Security and Locks ..... 9F-1  
 Seats ..... 9G-1  
 Interior Trim ..... 9H-1  
 Hood / Fenders / Doors ..... 9J-1  
 Body Structure ..... 9K-1  
 Paint / Coatings ..... 9L-1  
 Exterior Trim ..... 9M-1

**Control Systems** ..... 10-i  
 Precautions ..... 10-1  
 Body Electrical Control System ..... 10B-1  
 Immobilizer Control System ..... 10C-1  
 Keyless Start System ..... 10E-1

## Section 00

## Precautions

## CONTENTS

<b>Precautions</b> .....	<b>00-1</b>	Precautions for Electrical Circuit Service .....	00-8
<b>Precautions</b> .....	<b>00-1</b>	Air Bag Warning .....	00-10
Precautions for Vehicles Equipped with a Supplemental Restraint (Air Bag) System .....	00-1	Air Bag System Service Warning .....	00-10
General Precautions .....	00-4	Fastener Caution .....	00-10
Warning for Wheel (with tire) Removal .....	00-7	Suspension Caution .....	00-10
Warning for Handling Emergency Flat Tire Repair Kit .....	00-7	Wheels and Tires Caution .....	00-10
Precautions for Catalytic Converter .....	00-7	Precaution for Vehicle Equipped with ESP® System .....	00-11
Precautions for Installing Mobile Communication Equipment .....	00-7	Brake Caution .....	00-11
Precaution for CAN Communication System .....	00-7	<b>Repair Instructions</b> .....	<b>00-11</b>
		Electrical Circuit Inspection Procedure .....	00-11
		Intermittent and Poor Connection Inspection ....	00-13

# Precautions

## Precautions

### Precautions for Vehicles Equipped with a Supplemental Restraint (Air Bag) System

S7RS0B0000001

#### **▲ WARNING**

- The configuration of air bag system parts are as shown in the figure. When it is necessary to service (remove, reinstall and inspect) these parts, be sure to follow procedures described in Air Bag System section. Failure to follow proper procedures could result in possible air bag system activation, personal injury, damage to parts or air bag system being unable to activate when necessary.
- If the air bag system and another vehicle system both need repair, SUZUKI recommends that the air bag system be repaired first, to help avoid unintended air bag system activation.
- Do not modify the steering wheel, dashboard, or any other air bag system components. Modifications can adversely affect air bag system performance and lead to injury.
- If the vehicle will be exposed to temperatures over 93 °C (200 °F) (for example, during a paint baking process), remove the air bag system components beforehand to avoid component damage or unintended air bag system activation.

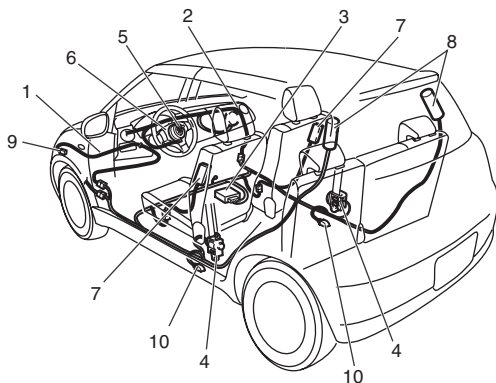

I4RS0B000001-02

1. Air bag wire harness (in floor, main and instrument panel harness)	6. Driver air bag (inflator) module
2. Passenger air bag (inflator) module	7. Side air bag (inflator) module (if equipped)
3. SDM	8. Curtain air bag (inflator) module (if equipped)
4. Seat belt pretensioner	9. Forward sensor
5. Contact coil	10. Side sensor (if equipped)

### Diagnosis

- When troubleshooting air bag system, be sure to follow "Diagnosis" in Air Bag System section. Bypassing these procedures may result in extended diagnostic time, incorrect diagnosis, and incorrect parts replacement.
- Never use electrical test equipment other than that specified.

#### **▲ WARNING**

Never attempt to measure the resistance of the air bag (inflator) modules (driver, passenger, side and curtain) and seat belt pretensioners (driver and passenger). It is very dangerous as the electric current from the tester may deploy the air bag or activate the pretensioner.

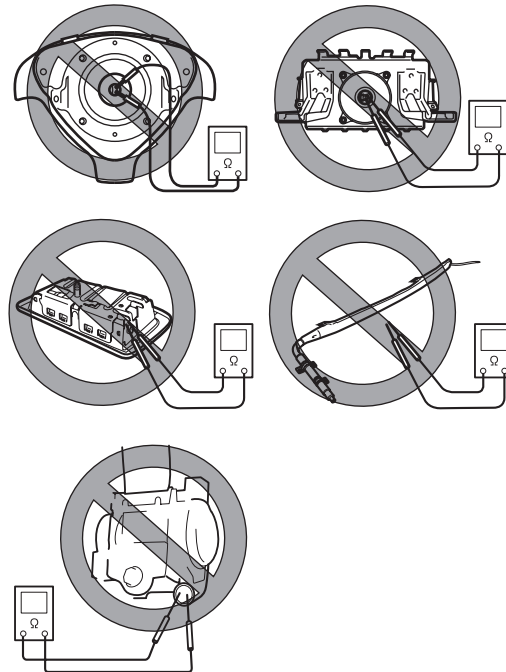

I4RS0A000002-02

## Servicing and Handling

**▲ WARNING**

Many of service procedures require disconnection of “A/BAG” fuse and all air bag (inflator) module(s) from initiator circuit to avoid an accidental deployment.

**Driver, Passenger, Side and Curtain Air Bag (Inflator) Modules**

- For handling and storage of a live air bag (inflator) module, select a place where the ambient temperature below 65 °C (150 °F), without high humidity and away from electric noise.
- When carrying a live air bag (inflator) module, make sure the bag opening is pointed away from you. In case of an accidental deployment, the bag will then deploy with minimal chance of injury. Never carry the air bag (inflator) module by the wires or connector on the underside of the module. When placing a live air bag (inflator) module on a bench or other surface, always face the bag up, away from the surface. As the live passenger air bag (inflator) module must be placed with its bag (trim cover) facing up, place it on the workbench with a slit (1) or use the workbench vise (2) to hold it securely at its lower mounting bracket (3). It is also prohibited to place anything on top of the trim cover and stack air bag (inflator) modules. This is necessary so that a free space is provided to allow the air bag to expand in the unlikely event of accidental deployment. Otherwise, personal injury may result.
- Never dispose of live (undeployed) air bag (inflator) modules (driver, passenger, side and curtain). If disposal is necessary, be sure to deploy them according to deployment procedures described in “Air Bag (Inflator) Module and Seat Belt Pretensioner Disposal in Section 8B” before disposal.
- The air bag (inflator) module immediately after deployment is very hot. Wait for at least half an hour to cool it off before proceeding the work.
- After an air bag (inflator) module has been deployed, the surface of the air bag may contain a powdery residue. This powder consists primarily of cornstarch (used to lubricate the bag as it inflates) and by-products of the chemical reaction. As with many service procedures, gloves and safety glasses should be worn.

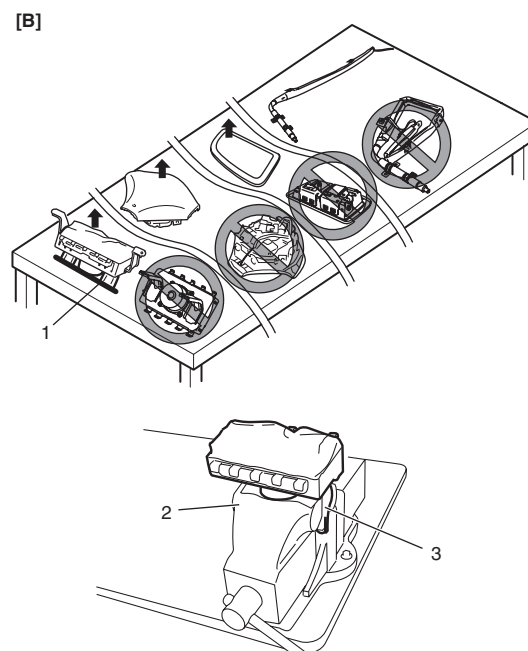
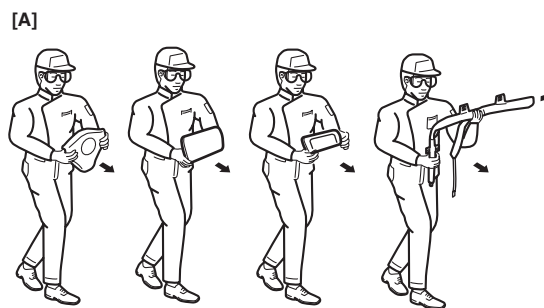

I4RS0A000003-02

[A]: Always carry air bag (inflator) module with trim cover (air bag opening) away from body.

[B]: Always place air bag (inflator) module on workbench with trim cover (air bag opening) up, away from loose objects.

**▲ WARNING**

**SDM**

- For handling and storage of a SDM, select a place where the ambient temperature below 65 °C (150 °F), without high humidity and away from electric noise.
- During service procedures, be very careful when handling a Sensing and Diagnostic Module (SDM). Never strike or jar the SDM.
- Never power up the air bag system when the SDM is not rigidly attached to the vehicle. All SDM and mounting bracket fasteners must be carefully torqued and the arrow must be pointing toward the front of the vehicle to ensure proper operation of the air bag system. The SDM could be activated when powered while not rigidly attached to the vehicle which could cause deployment and result in personal injury.

**▲ WARNING**

**Driver and Passenger Seat Belt Pretensioners**

- For handling and storage of a live seat belt pretensioner, select a place where the ambient temperature below 65 °C (150 °F), without high humidity and away from electric noise.
- Never carry seat belt pretensioner by wire or connector of pretensioner. When placing a live seat belt pretensioner on the workbench or some place like that, never put something on seat belt pretensioner. Otherwise, personal injury may result.
- Never dispose of live (inactivated) seat belt pretensioners (drive and passenger). If disposal is necessary, be sure to activate them according to activation procedures described in “Air Bag (Inflator) Module and Seat Belt Pretensioner Disposal in Section 8B” before disposal.
- The seat belt pretensioner immediately after activation is very hot. Wait for at least half an hour to cool it off before proceeding the work.
- With many service procedures, gloves and safety glasses should be worn to prevent any possible irritation of the skin or eyes.

- Even when the accident was light enough not to cause air bags to activate, be sure to inspect system parts and other related parts according to instructions under “Repair and Inspection Required after Accident in Section 8B”.
- When servicing parts other than air bag system, if shocks may be applied to air bag system component parts, remove those parts beforehand.
- When handling the air bag (inflator) modules (driver, passenger, side and curtain), seat belt pretensioners (driver and passenger), forward sensor, side sensors or SDM, be careful not to drop it or apply an impact to it. If an excessive impact was applied, never attempt disassembly or repair but replace it with a new one.
- When grease, cleaning agent, oil, water, etc. has got onto air bag (inflator) modules (driver, passenger, side and curtain) or seat belt pretensioners (drive and passenger), wipe off immediately with a dry cloth.
- Air bag wire harness is included in floor and instrument panel wire harnesses. Air bag wire harness branched off from floor and instrument panel wire harnesses can be identified easily as it is covered with a yellow protection tube and it has yellow connectors. Be very careful when handling it.
- When an open in air bag wire harness, damaged wire harness, connector or terminal is found, replace wire harness, connectors and terminals as an assembly.
- Do not apply power to the air bag system unless all components are connected or a diagnostic flow requests it, as this will set a DTC.
- Never use air bag system component parts from another vehicle.
- When using electric welding, be sure to disconnect all air bag (inflator) module connectors and pretensioner connectors from air bag wire harness respectively.
- Never expose air bag system component parts directly to hot air (drying or baking the vehicle after painting) or flames.
- WARNING / CAUTION labels are attached on each part of air bag system components. Be sure to follow the instructions.
- After vehicle is completely repaired, perform “Air Bag Diagnostic System Check in Section 8B”.

## General Precautions

S7RS0B0000002

The WARNING and CAUTION describe some general precautions that you should observe when servicing a vehicle. These general precautions apply to many of the service procedures, and they will not necessarily be repeated with each procedure to which they apply.

### **▲ WARNING**

- Whenever raising a vehicle for service, be sure to follow the instructions under “Vehicle Lifting Points in Section 0A”.
- When it is necessary to do service work with the engine running, make sure that the parking brake is set fully and the transmission is in Neutral (for manual transmission vehicles) or Park (for automatic transmission vehicles). Keep hands, hair, clothing, tools, etc. away from the fan and belts when the engine is running.
- When it is necessary to run the engine indoors, make sure that the exhaust gas is forced outdoors.
- Do not perform service work in areas where combustible materials can come in contact with a hot exhaust system. When working with toxic or flammable materials (such as gasoline and refrigerant), make sure that the area you work in is well-ventilated.
- To avoid getting burned, keep away from hot metal parts such as the radiator, exhaust manifold, tail pipe, muffler, etc.
- New and used engine oil can be hazardous. Children and pets may be harmed by swallowing new or used oil. Keep new and used oil and used engine oil filters away from children and pets. Continuous contact with used engine oil has been found to cause [skin] cancer in laboratory animals. Brief contact with used oil may irritate skin. To minimize your exposure to used engine oil, wear a long-sleeve shirt and moisture-proof gloves (such as dish washing gloves) when changing engine oil. If engine oil contacts your skin, wash thoroughly with soap and water. Launder any clothing or rags if wet with oil, recycle or properly dispose of used oil and filters.

- Be sure to observe following instructions when handling service materials such as fuel, oil, fluid, coolant, grease, sealant, thread lock cement, etc. Otherwise, your health may be ruined.
  - Whenever handling any of these service materials, wear safety glasses to protect your eyes. If it gets into your eye, it may cause inflammation.
  - Whenever handling any of these service materials, wear moisture-proof gloves to protect your skin. If it adheres to your skin, it may cause inflammation.
  - Do not swallow any of these service materials. It would cause diarrhea or nausea.
  - Keep all these materials out of children’s reach.
- Make sure the bonnet is fully closed and latched before driving. If it is not, it can fly up unexpectedly during driving, obstructing your view and resulting in an accident.

- Before starting any service work, cover fenders, seats and any other parts that are likely to get scratched or stained during servicing. Also, be aware that what you wear (e.g., buttons) may cause damage to the vehicle’s finish.

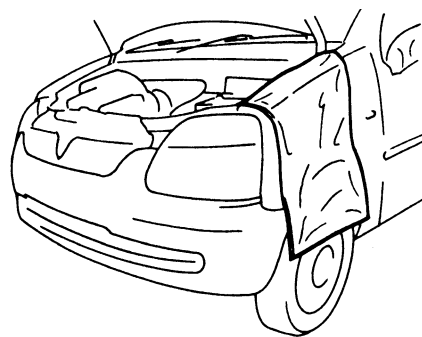

I2RH01010025-01

## 00-5 Precautions:

- When performing service to electrical parts that does not require use of battery power, disconnect the negative cable of the battery.
- When disconnecting the negative cable from the battery, be careful to the following.
  - Check and record DTCs in ECM and HVAC control module if necessary before disconnecting.
  - Record displayed contents of the clock and/or audio system, etc. before disconnecting and reset it as before after connecting.
  - For vehicle equipped with electric throttle body system, perform electric throttle body system calibration referring to “Electric Throttle Body System Calibration in Section 1C” after reconnecting the negative cable to the battery.
  - For vehicle equipped with ESP®, calibrate steering angle sensor referring to “Sensor Calibration in Section 4F” after reconnecting the negative cable to the battery.

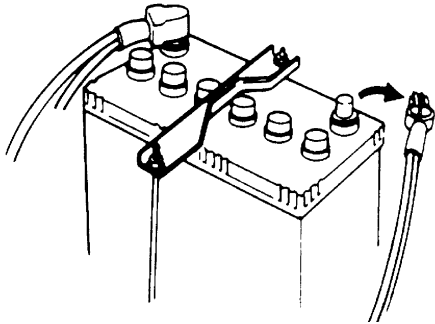

I2RH01010026-01

- When removing the battery, be sure to disconnect the negative cable first and then the positive cable. When reconnecting the battery, connect the positive cable first and then the negative cable, and replace the terminal cover.

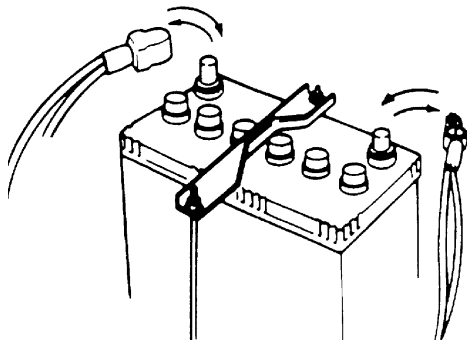

I2RH01010027-01

- When removing parts that are to be reused, be sure to keep them arranged in an orderly manner so that they may be reinstalled in the proper order and position.

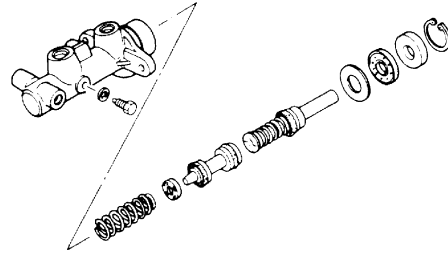

I2RH01010028-01

- Whenever you use oil seals, gaskets, packing, O-rings, locking washers, split pins, self-locking nuts, and certain other parts as specified, be sure to use new ones. Also, before installing new gaskets, packing, etc., be sure to remove any residual material from the mating surfaces.

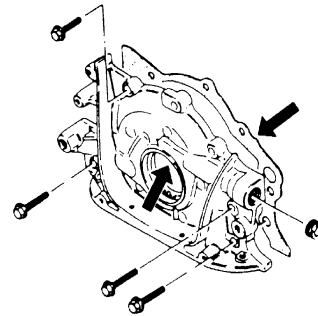

I2RH01010029-01

- Make sure that all parts used in reassembly are perfectly clean. When use of a certain type of lubricant, bond or sealant is specified, be sure to use the specified type.

**“A”:** Water tight sealant 99000-31250 (SUZUKI Bond No.1207F)

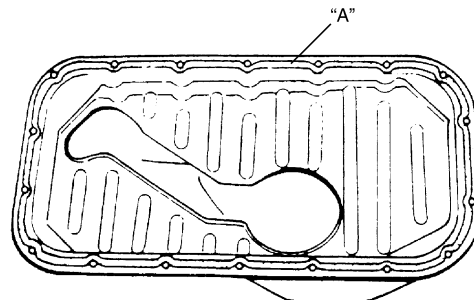

I2RH01010030-01



- Be sure to use special tools when instructed.

**Special tool**

(A): 09917-98221

(B): 09916-58210

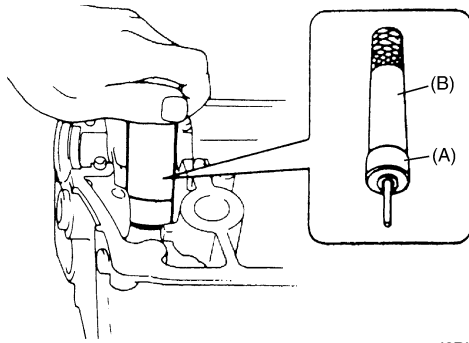

I2RH01010031-01

- When disconnecting vacuum hoses, attach a tag describing the correct installation positions so that the hoses can be reinstalled correctly.

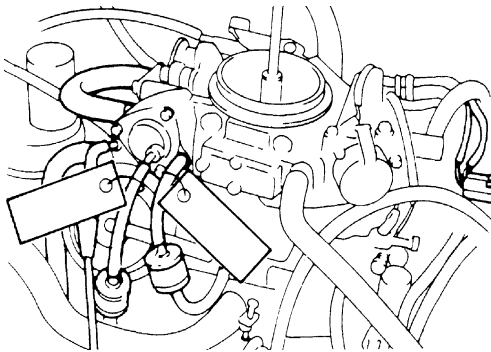

I2RH01010032-01

- After servicing fuel, oil, coolant, vacuum, exhaust or brake systems, check all lines related to the system for leaks.

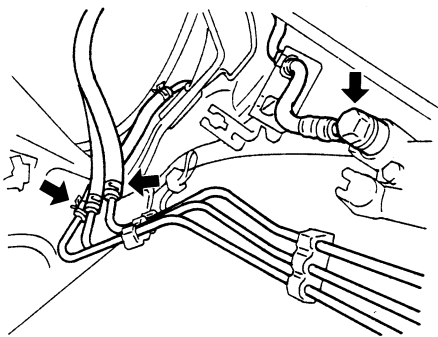

I2RH01010033-01

- For vehicles equipped with fuel injection systems, never disconnect the fuel line between the fuel pump and injector without first releasing the fuel pressure, or fuel can be sprayed out under pressure.
- When performing a work that produces a heat exceeding 80 °C (176 °F) in the vicinity of the electrical parts, remove the heat sensitive electrical part(s) beforehand.

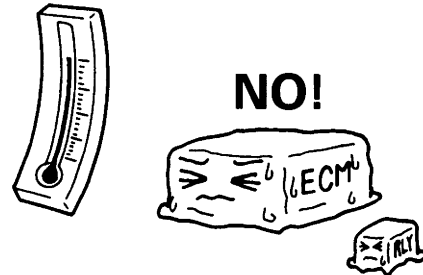

I2RH01010034-01

- Use care not to expose connectors and electrical parts to water which will be a cause of a trouble.



I2RH01010035-01

- Always be careful not to handle electrical parts (computer, relay, etc.) in a rough manner or drop them.

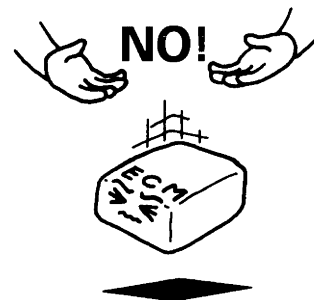

I2RH01010036-01

**Warning for Wheel (with tire) Removal**

S7RS0B0000003

**▲ WARNING**

When removing any of these wheels installed with wheel bolts, never remove all wheel bolts at the same time. Leave at least 1 bolt for each wheel as it is to prevent wheel from dropping. When removing this remaining 1 bolt, hold wheel and tire so as not to allow them to come off.

**Warning for Handling Emergency Flat Tire Repair Kit**

S7RS0B0000004

**▲ WARNING**

If vehicle is equipped with Emergency Flat Tire Repair Kit instead of spare tire, be sure to observe "Precaution for Emergency Flat Tire Repair Kit in Section 2D" when handling Emergency Flat Tire Repair Kit and repairing flat tire. Otherwise, your health may be ruined or it will be impossible to repair flat tire.

**Precautions for Catalytic Converter**

S7RS0B0000005

For vehicles equipped with a catalytic converter, use only unleaded gasoline and be careful not to let a large amount of unburned gasoline enter the converter or it can be damaged.

- Conduct a spark jump test only when necessary, make it as short as possible, and do not open the throttle.
- Conduct engine compression checks within the shortest possible time.
- Avoid situations which can result in engine misfire (e.g. starting the engine when the fuel tank is nearly empty.)

**Precautions for Installing Mobile Communication Equipment**

S7RS0B0000006

When installing mobile communication equipment such as CB (Citizens-Band)-radio or cellular-telephone, be sure to observe the following precautions. Failure to follow cautions may adversely affect electronic control system.

- Keep the antenna as far away as possible from the vehicle's electronic control unit.
- Keep the antenna feeder more than 20 cm (7.9 in.) away from electronic control unit and its wire harnesses.
- Do not run the antenna feeder parallel with other wire harnesses.
- Confirm that the antenna and feeder are correctly adjusted.

**Precaution for CAN Communication System**

S7RS0B0000007

- The loose (1) in the wire harnesses twist of the CAN lines except around the connector (3) should be within 100 mm (3.9 in.). Refer to the wiring diagram for the CAN lines discrimination. Excessively-loosed lines may be influenced by the electric noise.

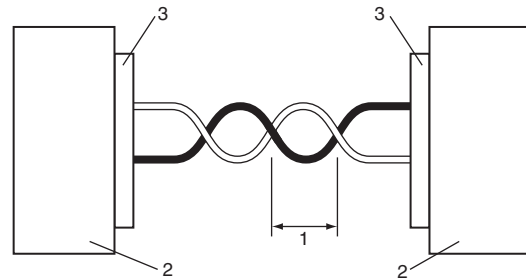

I4JA01000002-01

- Do not connect terminals of the CAN line using a bypass wire (1). Otherwise, the CAN line may be influenced by the electric noise.

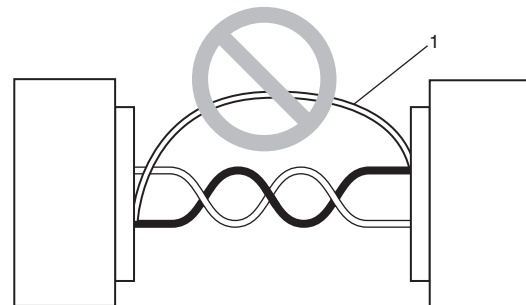

I4JA01000003-01

**Precautions for Electrical Circuit Service**

S7RS0B0000008

- When replacing a fuse, make sure to use a fuse of the specified capacity. Use of a fuse with a larger capacity will cause a damage to the electrical parts and a fire.

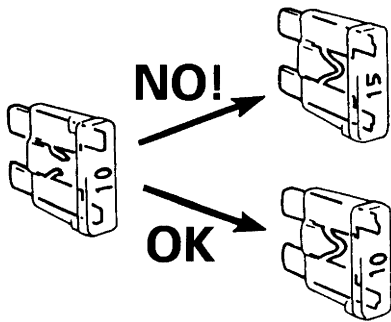

I2RH01010038-01

- When disconnecting and connecting coupler, make sure to turn ignition switch OFF, or electronic parts may get damaged.

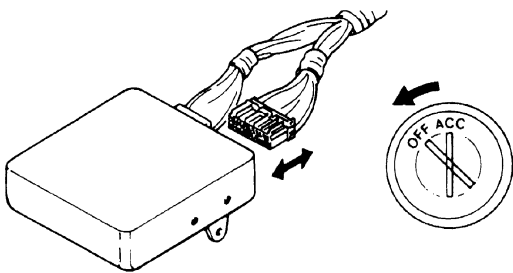

I2RH01010039-01

- When disconnecting connectors, never pull the wiring harness. Unlock the connector lock first and then pull them apart by holding connectors themselves.

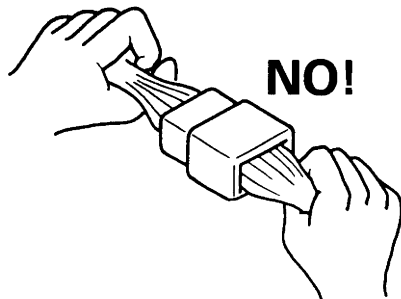

I2RH01010040-01

- When connecting connectors, also hold connectors and put them together until they lock securely (a click is heard).

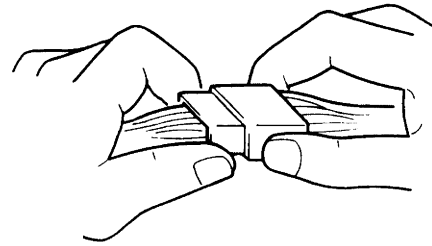

I2RH01010041-01

- When installing the wiring harness, fix it with clamps so that no slack is left.

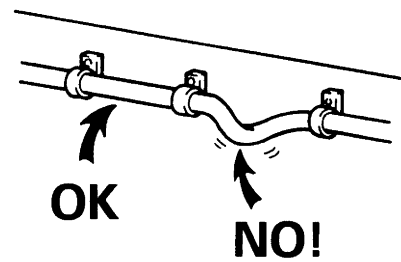

I2RH01010042-01

- When installing vehicle parts, be careful so that the wiring harness is not interfered with or caught by any other part.

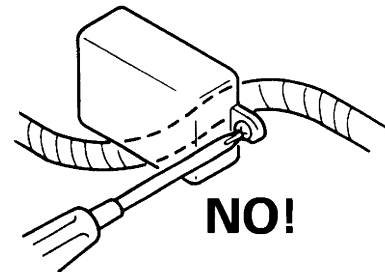

I2RH01010043-01

- To avoid damage to the harness, protect its part which may contact against a part forming a sharp angle by winding tape or the like around it.

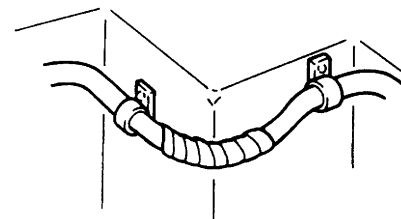

I2RH01010044-01

## 00-9 Precautions:

- Be careful not to touch the electrical terminals of parts which use microcomputers (e.g. electronic control unit like as ECM, PCM, P/S controller, etc.). The static electricity from your body can damage these parts.

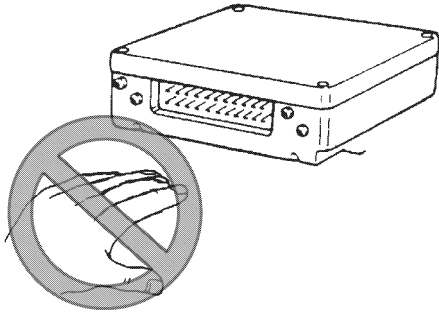

I3RMOA000004-01

- Never connect any tester (voltmeter, ohmmeter, or whatever) to electronic control unit when its coupler is disconnected. Attempt to do it may cause damage to it.
- Never connect an ohmmeter to electronic control unit with its coupler connected to it. Attempt to do it may cause damage to electronic control unit and sensors.
- Be sure to use a specified voltmeter / ohmmeter. Otherwise, accurate measurements may not be obtained or personal injury may result. If not specified, use a voltmeter with high impedance ( $M \Omega/V$  minimum) or a digital type voltmeter.
- When taking measurements at electrical connectors using a tester probe, be sure to insert the probe (2) from the wire harness side (backside) of the connector (1).

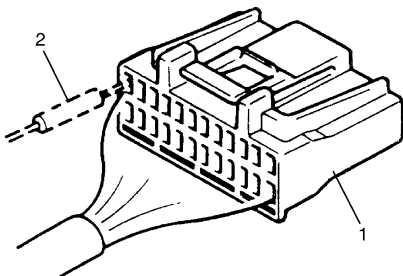

I2RH01010046-01

- When connecting meter probe (2) from terminal side of coupler (1) because it can't be connected from harness side, use extra care not to bend male terminal of coupler or force its female terminal open for connection. In case of such coupler as shown connect probe as shown to avoid opening female terminal. Never connect probe where male terminal is supposed to fit.

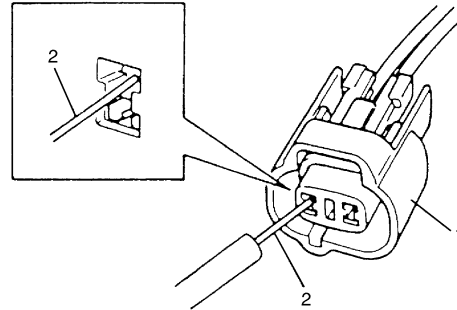

I2RH01010047-01

- When checking connection of terminals, check its male half for bend and female half for excessive opening and both for locking (looseness), corrosion, dust, etc.
- Before measuring voltage at each terminal, check to make sure that battery voltage is 11 V or higher. Such terminal voltage check at low battery voltage will lead to erroneous diagnosis.

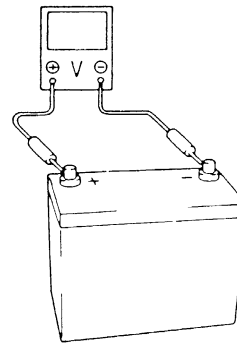

I2RH01010048-01

**Air Bag Warning**

S7RS0B0000009

**⚠ WARNING**

For vehicles equipped with Supplemental Restraint (Air Bag) System:

- Service on and around the air bag system components or wiring must be performed only by an authorized SUZUKI dealer. Refer to “Air Bag System Components, Wiring and Connectors Location in Section 8B” in order to confirm whether you are performing service on or near the air bag system components or wiring. Please observe all WARNINGS in Air Bag System section and “Precautions on Service and Diagnosis of Air Bag System in Section 8B” before performing service on or around the air bag system components or wiring. Failure to follow WARNINGS could result in unintentional activation of the system or could render the system inoperative. Either of these two conditions may result in severe injury.
- Technical service work must be started at least 90 seconds after the ignition switch is turned to the LOCK position and the negative cable is disconnected from the battery. Otherwise, the system may be activated by reserve energy in the Sensing and Diagnostic Module (SDM).

**Air Bag System Service Warning**

S7RS0B0000010

**⚠ WARNING**

- Service on or around the air bag system components or wiring must be performed only by an authorized SUZUKI dealer. Please observe all WARNINGS in Air Bag System section and “Precautions on Service and Diagnosis of Air Bag System in Section 8B” before performing service on or around the air bag system components or wiring. Failure to follow WARNINGS could result in unintended activation of the system or could render the system inoperative. Either of these two conditions may result in severe injury.
- The procedures in the air bag system section must be followed in the order listed to disable the air bag system temporarily and prevent false DTCs from setting. Failure to follow procedures could result in possible activation of the air bag system, personal injury or otherwise unneeded air bag system repairs.

**Fastener Caution**

S7RS0B0000011

**⚠ CAUTION**

When fasteners are removed, always reinstall them at the same location from which they were removed. If a fastener needs to be replaced, use the correct part number fastener for that application. If the correct part number fastener is not available, a fastener of equal size and strength (or stronger) may be used. Fasteners that are not reused, and those requiring thread-locking compound, will be called out. The correct torque value must be used when installing fasteners that require it. If the conditions are not followed, parts or system damage could result.

**Suspension Caution**

S7RS0B0000012

**⚠ CAUTION**

- All suspension fasteners are an important attaching part in that it could affect the performance of vital parts and systems, and/or could result in major repair expense. They must be replaced with one of the same part number or with an equivalent part if replacement becomes necessary. Do not use a replacement part of lesser quality or substitute design. Torque values must be used as specified during reassembly to assure proper retention of this part.
- Never attempt to heat, quench or straighten any suspension part. Replace it with a new part or damage to the part may result.

**Wheels and Tires Caution**

S7RS0B0000013

**⚠ CAUTION**

All wheel fasteners are important attaching parts in that they could affect the performance of vital parts and systems, and/or could result in major repair expense. They must be replaced with one of the same part number or with an equivalent part if replacement becomes necessary. Do not use a replacement part of lesser quality or substitute design. Torque values must be used as specified during reassembly to assure proper retention of all parts. There is to be no welding as it may result in extensive damage and weakening of the metal.

## Precaution for Vehicle Equipped with ESP® System

S7RS0B0000015

- When testing with any of the following equipments (when vehicle is tested by rotating wheels (tires) under vehicle stop), be sure to deactivate ESP® system referring to “Precautions in Speedometer Test or Other Tests in Section 4F” to obtain correct data.
  - 2 or 4-wheel chassis dynamometer
  - Speedometer tester
  - Brake tester
  - Etc.

### ESP® control module

- When ESP® control module is removed / installed, do not use impact wrenches which generate shock or impact to avoid damaging sensors in ESP® control module.
- When any of the following operation is done, calibrate steering angle sensor referring to “Sensor Calibration in Section 4F”.
  - When battery or dome fuse is removed.
  - When steering angle sensor is replaced.

## Brake Caution

S7RS0B0000014

### ⚠ CAUTION

**All brake fasteners are important attaching parts in that they could affect the performance of vital parts and systems, and/or could result in major repair expense. They must be replaced with one of same part number or with an equivalent part if replacement becomes necessary. Do not use a replacement part of lesser quality or substitute design. Torque values must be used as specified during reassembly to assure proper retention of all parts. There is to be no welding as it may result in extensive damage and weakening of the metal.**

## Repair Instructions

### Electrical Circuit Inspection Procedure

S7RS0B0006001

While there are various electrical circuit inspection methods, described here is a general method to check its open and short circuit by using an ohmmeter and a voltmeter.

#### Open Circuit Check

Possible causes for the open circuit are as follows. As the cause is in the connector or terminal in many cases, they need to be checked particularly carefully.

- Loose connection of connector
- Poor contact of terminal (due to dirt, corrosion or rust on it, poor contact tension, entry of foreign object etc.)
- Wire harness being open

When checking system circuits including an electronic control unit such as ECM, TCM, ABS control module, etc., it is important to perform careful check, starting with items which are easier to check.

- 1) Disconnect negative (–) cable from battery
- 2) Check each connector at both ends of the circuit being checked for loose connection. Also check lock condition of connector if equipped with connector lock.

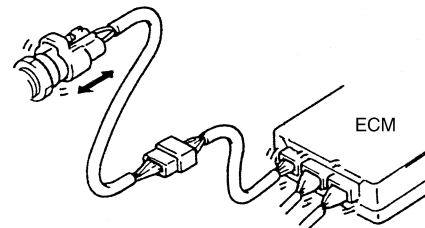

I2RH01010049-01

- 3) Using a test male terminal, check both terminals of the circuit being checked for contact tension of its female terminal. Check each terminal visually for poor contact (possibly caused by dirt, corrosion, rust entry of foreign object, etc.). At the same time, check to make sure that each terminal is locked in the connector fully.

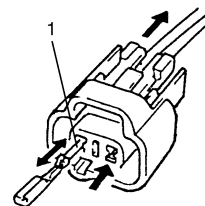

I2RH01010050-01

1. Check contact tension by inserting and removing just for once.

- 4) Using continuity check or voltage check the following procedure, check the wire harness for open circuit and poor connection with its terminals. Locate abnormality, if any.

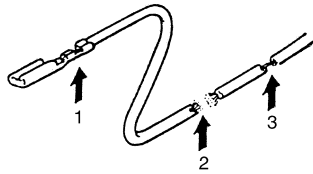

I2RH01010051-01

1. Looseness of crimping
2. Open
3. Thin wire (single strand of wire)

**Continuity Check**

- 1) Measure resistance between connector terminals at both ends of the circuit being checked (between "A-1" and "C-1" in the figure). If no continuity is indicated (infinity or over limit), that means that the circuit is open between terminals "A-1" and "C-1".

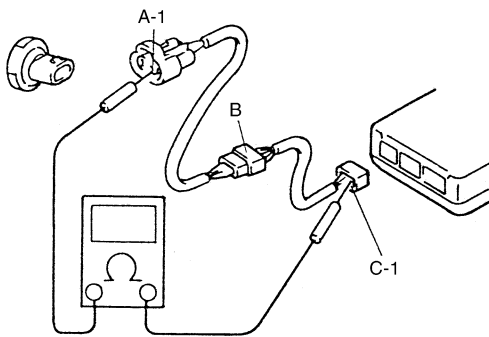

I2RH01010052-01

- 2) Disconnect the connector included in the circuit (connector-B in the figure) and measure resistance between terminals "A-1" and "B-1". If no continuity is indicated, that means that the circuit is open between terminals "A-1" and "B-1". If continuity is indicated, there is an open circuit between terminals "B-1" and "C-1" or an abnormality in connector-B.

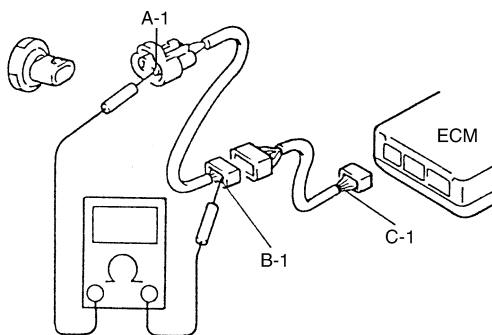

I2RH01010053-01

**Voltage Check**

If voltage is supplied to the circuit being checked, voltage check can be used as circuit check.

- 1) With all connectors connected and voltage applied to the circuit being checked, measure voltage between each terminal and body ground.
- a) If measurements were taken as shown in the figure and results were as listed in the following, it means that the circuit is open between terminals "B-1" and "A-1".

**Voltage between**

"C-1" and body ground: Approx. 5 V

"B-1" and body ground: Approx. 5 V

"A-1" and body ground: 0 V

- b) Also, if measured values were as listed in the following, it means that there is a resistance (abnormality) of such level that corresponds to the voltage drop in the circuit between terminals "A-1" and "B-1".

**Voltage between**

"C-1" and body ground: Approx. 5 V

"B-1" and body ground: Approx. 5 V

"A-1" and body ground: Approx. 3 V

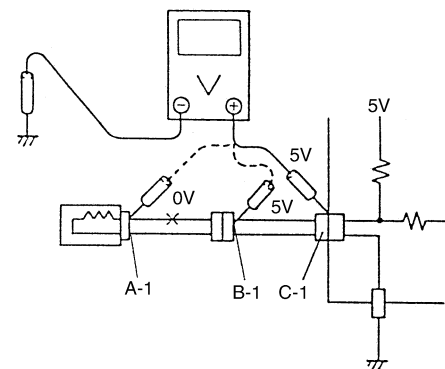
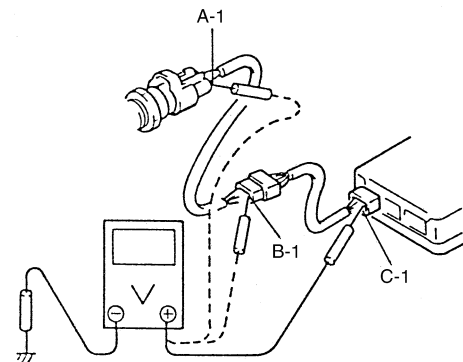

I5RH01000005-01

**Short Circuit Check (Wire Harness to Ground)**

- 1) Disconnect negative (-) cable at battery.
- 2) Disconnect connectors at both ends of the circuit to be checked.

**NOTE**

**If the circuit to be checked is connected to other parts (1), disconnect all connectors of those parts.**

**Otherwise, diagnosis will be misled.**

- 3) Measure resistance between terminal at one end of circuit ("A-1" terminal in the figure) and body ground. If continuity is indicated, it means that there is a short to ground between terminals "A-1" and "C-1" of the circuit.

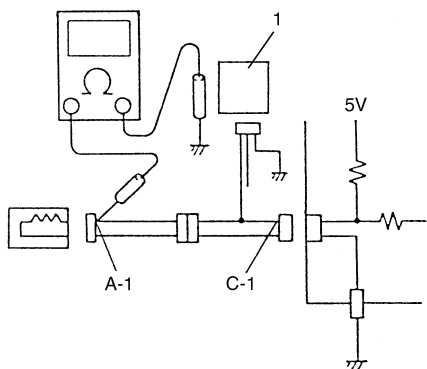
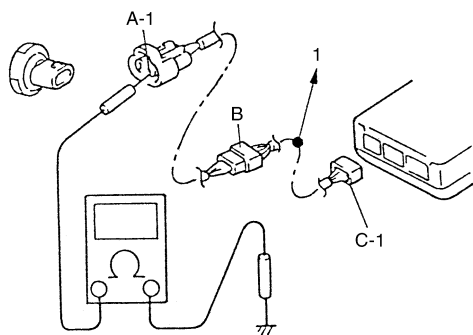

I5RH01000006-01

- 4) Disconnect the connector included in circuit (connector-B) and measure resistance between "A-1" and body ground. If continuity is indicated, it means that the circuit is shorted to the ground between terminals "A-1" and "B-1".

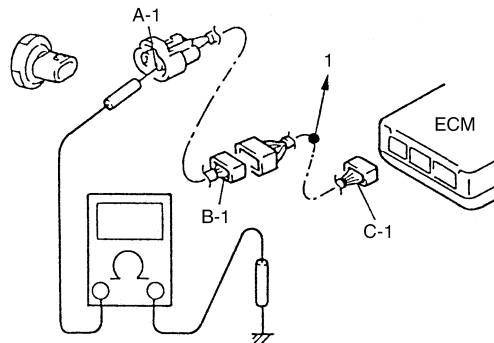

I2RH01010056-01

1. To other parts

**Intermittent and Poor Connection Inspection**

S7RS0B0006002

Most intermittent are caused by faulty electrical connections or wiring, although a sticking relay or solenoid can occasionally be at fault. When checking it for proper connection, perform careful check of suspect circuits for:

- Poor mating of connector halves, or terminals not fully seated in the connector body (backed out).
- Dirt or corrosion on the terminals. The terminals must be clean and free of any foreign material which could impede proper terminal contact. However, cleaning the terminal with a sand paper or the like is prohibited.
- Damaged connector body, exposing the terminals to moisture and dirt, as well as not maintaining proper terminal orientation with the component or mating connector.

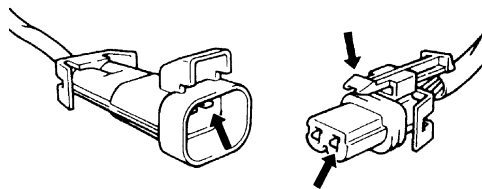

I2RH01010057-01



- Improperly formed or damaged terminals.  
Check each connector terminal in problem circuits carefully to ensure good contact tension by using the corresponding mating terminal.  
If contact tension is not enough, reform it to increase contact tension or replace.

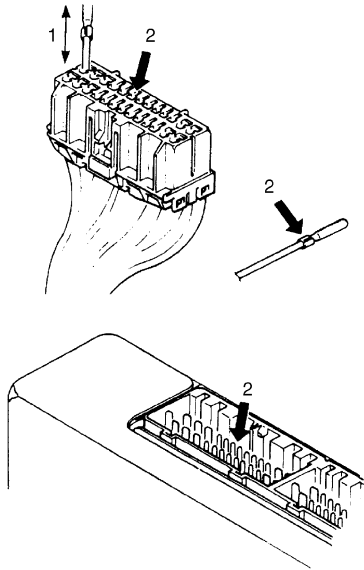

I5RH01000007-01

- |   |
|---|
| 1. Check contact tension by inserting and removing just once. |
| 2. Check each terminal for bend and proper alignment.         |

- Poor terminal-to-wire connection.  
Check each wire harness in problem circuits for poor connection by shaking it by hand lightly. If any abnormal condition is found, repair or replace.

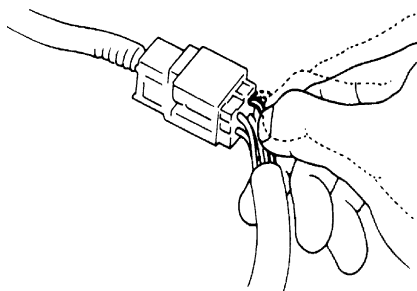

I2RH01010059-01

- Wire insulation which is rubbed through, causing an intermittent short as the bare area touches other wiring or parts of the vehicle.
- Wiring broken inside the insulation. This condition could cause continuity check to show a good circuit, but if only 1 or 2 strands of a multi-strand-type wire are intact, resistance could be far too high. If any abnormality is found, repair or replace.

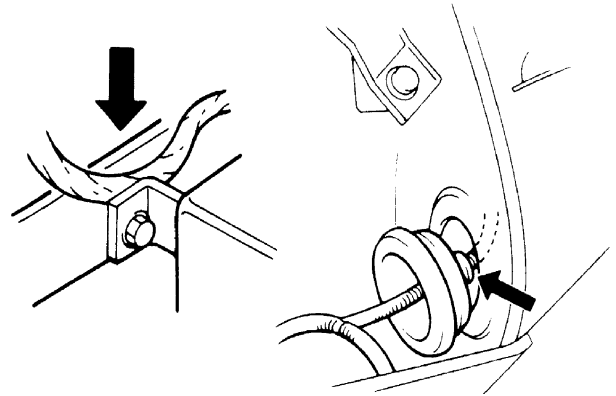

I2RH01010060-01

