

Foreword

This manual contains procedures for diagnosis, maintenance, adjustments, minor service operations, replacement of components (Service) and for disassembly and assembly of major components (Unit Repair Overhaul).

Model : APV.

The contents are classified into sections each of which is given a section number as indicated in the Table of Contents on next page. And on the first page of each individual section is an index of that section.

This manual should be kept in a handy place for ready reference of the service work.

Strict observance of the so specified items will enable one to obtain the full performance of the vehicle.

When replacing parts or servicing by disassembling, it is recommended to use SUZUKI genuine parts, tools and service materials (lubricant, sealants, etc.) as specified in each description.

All information, illustrations and specifications contained in this literature are based on the latest product information available at the time of publication approval. And used as the main subject of description is the vehicle of standard specifications among others.

Therefore, note that illustrations may differ from the vehicle being actually serviced.

The right is reserved to make changes at any time without notice.

PT. INDOMOBIL SUZUKI INTERNATIONAL
SERVICE 4W DEPARTMENT

Important

WARNING/CAUTION/NOTE

Please read this manual and follow its instructions carefully. To emphasize special information, the words **WARNING**, **CAUTION** and **NOTE** have special meanings. Pay special attention to the messages highlighted by these signal words.

WARNING:

Indicates a potential hazard that could result in death or injury.

CAUTION:

Indicates a potential hazard that could result in vehicle damage.

NOTE:

Indicates special information to make maintenance easier or instructions clearer.

WARNING:

This service manual is intended for authorized SUZUKI dealers and qualified service mechanics only. Inexperienced mechanics or mechanics without the proper tools and equipment may not be able to properly perform the services described in this manual. Improper repair may result in injury to the mechanic and may render the vehicle unsafe for the driver and passengers.

WARNING:

For vehicles equipped with a Supplemental Restraint (Air Bag) System :

- Service on and around the air bag system components or wiring must be performed only by an authorized SUZUKI dealer.
Refer to “Air Bag System Components and Wiring Location View” under “General Description” in air bag system section in order to confirm whether you are performing service on or near the air bag system components or wiring. Please observe all WARNINGS and “Service Precautions” under “On-Vehicle Service” in air bag system section before performing service on or around the air bag system components or wiring. Failure to follow WARNINGS could result in unintentional activation of the system or could render the system inoperative. Either of these two conditions may result in severe injury.
- If the air bag system and another vehicle system both need repair, SUZUKI recommends that the air bag system be repaired first, to help avoid unintended air bag system activation.
- Do not modify the steering wheel, instrument panel or any other air bag system component (on or around air bag system components or wiring). Modifications can adversely affect air bag system performance and lead to injury.
- If the vehicle will be exposed to temperatures over 93°C (200°F) (for example, during a paint baking process), remove the air bag system components (air bag (inflator) module, sensing and diagnostic module (SDM), seat belt pretensioner (if equipped) beforehand to avoid component damage or unintended activation.

The circle with a slash in this manual means “Don’t do this” or “Don’t let this happen”.



Table of Contents

GENERAL INFORMATION	
General Information	0A
Maintenance and Lubrication	0B
HEATING AND AIR CONDITIONING	
Heater and Ventilation	1A
Air Conditioning	1B
STEERING, SUSPENSION, WHEELS AND TIRES	
Steering, Suspension, Wheels and Tires	3
Wheel Alignment	3A
Manual Rack & Pinion	3B
Power Steering (P/S) System	3B1
Steering Wheel and Column	3C
Front Suspension	3D
Rear Suspension	3E
Wheels and Tires	3F
DRIVE SHAFT/PROP. SHAFT	
Propeller Shafts	4B
BRAKE SYSTEM	
Brakes	5
ENGINE	
Engine General Information and Diagnosis (G16)	6-1
Engine Mechanical (G16)	6A
Engine Cooling	6B
Engine Fuel	6C
Engine and Emission Control System (G16)	6E1
Ignition System (G16)	6F
Cranking System (Reduction Type)	6G
Charging System	6H
Exhaust System	6K

TRANSMISSION, CLUTCH AND DIFFERENTIAL	
Manual Transmission	7A
Automatic Transmission	7B
Clutch	7C
Differential (Rear)	7F
BODY ELECTRICAL SYSTEM	
Wiring Diagram	8A
Lighting System	8B
Instrumentation/Driver Information	8C
Windows, Mirrors, Security and Locks	8D
Immobilizer Control System (if equipped)	8G
BODY SERVICE	
9	
RESTRAINT SYSTEM	
10	
Seat Belt	10A
Air Bag System	10B

0A	
0B	7A
	7B
1A	7C
1B	7F
	8
	8A
3	8B
3A	8C
3B	8D
3B1	8G
3C	9
3D	10
3E	10A
3F	10B
4B	
5	
6-1	
6A	
6B	
6C	
6E1	
6F	
6G	
6H	
6K	

NOTE:

The screen toned Section 8A is in Wiring Diagram Manual.

SECTION 0A

0A

GENERAL INFORMATION

CONTENTS

How To Use This Manual	0A-2	Identification Information	0A-17
Precautions	0A-3	Vehicle Identification Number	0A-17
Precaution for Vehicle Equipped with a Supplemental Restraint (Air Bag) System.....	0A-3	Engine Identification Number	0A-17
Diagnosis.....	0A-3	Transmission Identification Number.....	0A-17
Service and Handling	0A-4	Warning, Caution and Information Labels..	0A-18
General Precautions	0A-6	Vehicle Lifting Points	0A-19
Precautions for Catalytic Converter.....	0A-9	Abbreviations and Symbols May Be Used In This Manual	0A-21
Precaution for Installing Mobile Communication Equipment	0A-9	Fastener Information	0A-24
Precautions for Vehicle Hooks	0A-9	Metric Fasteners	0A-24
Precautions for Electrical Circuit Service	0A-10	Fastener Strength Identification	0A-24
Electrical Circuit Inspection Procedure.....	0A-12	Standard Tightening Torque	0A-24
Intermittent and Poor Connection	0A-15		

How To Use This Manual

- 1) There is a "TABLE OF CONTENTS" for the whole manual on the third page of this manual, whereby you can easily find the section that offers the information you need. Also, there is a "CONTENTS" on the first page of each section, where the main items in that section are listed.
- 2) Each section of this manual has its own pagination. It is indicated at the top of each page along with the section name.
- 3) The special tool usage and torque specification are given as shown in figure below.

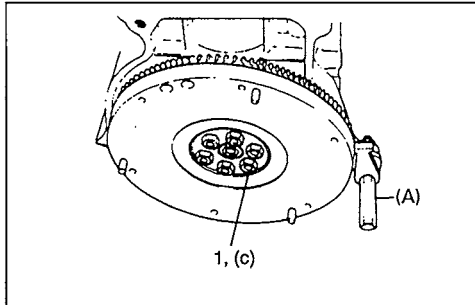

- 6) Install oil pump. Refer to "Oil pump".
- 7) Install flywheel (for M/T vehicle) or drive plate (for A/T vehicle).
Using special tool, lock flywheel or drive plate, and tighten flywheel or drive plate bolts to specified torque.

Special Tool

(A): 09924-17810

Tightening Torque

(c): 78 N·m (7.8 kg-m, 56.0 lb-ft)

1. Flywheel bolts or drive plate bolts for A/T vehicle

- 4) A number of abbreviations are used in the text.
For their full explanations, refer to "Abbreviations and Symbols May Be Used In This Manual" of this section.
- 5) The SI, metric and foot-pound systems are used as units in this manual.
- 6) "Diagnosis" are included in each section as necessary.
- 7) At the end of each section, there are descriptions of "Special Tool", "Required Service Material" and "Tightening Torque Specification" that should be used for the servicing work described in that section.

Precautions

Precaution for Vehicle Equipped with a Supplemental Restraint (Air Bag) System

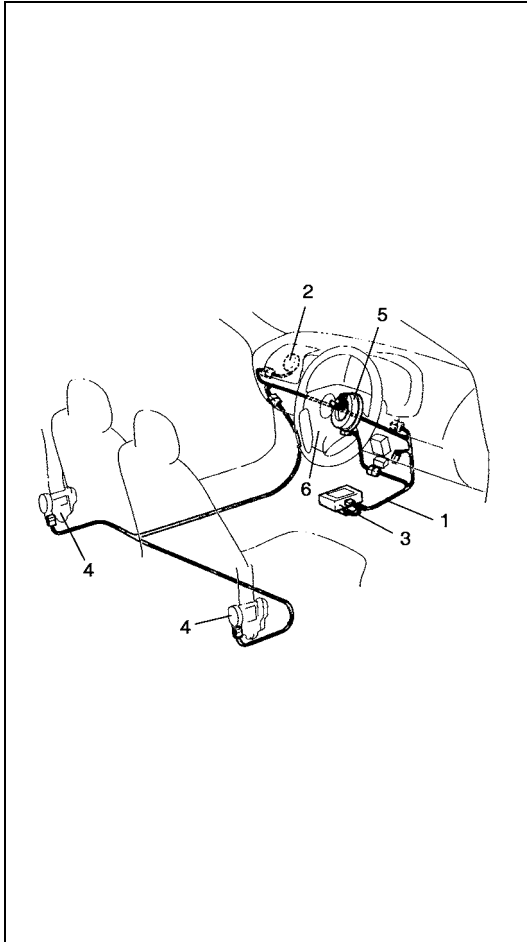

WARNING:

- The configuration of air bag system parts are shown in the figure. When it is necessary to service (remove, reinstall and inspect) these parts, be sure to follow procedures described in Section 10B. Failure to follow proper procedures could result in possible air bag system activation, personal injury, damage to parts or air bag system being unable to activate when necessary.
- If the air bag system and another vehicle system both need repair, SUZUKI recommends that the air bag system be repaired first, to help avoid unintended air bag system activation.
- Do not modify the steering wheel, dashboard, or any other air bag system components. Modifications can adversely affect air bag system performance and lead to injury.
- If the vehicle will be exposed to temperature over 93°C (200°F) (For example, during a paint baking process), remove the air bag system components beforehand to avoid component damage or unintended air bag system activation.

1. Air bag wire harness (in main and floor harness)	4. Seat belt pretensioner
2. Passenger air bag (inflator) module	5. Contact coil
3. SDM	6. Driver air bag (inflator) module

Diagnosis

- When trouble shooting air bag system, be sure to follow "Diagnosis" in Section 10B. Bypassing these procedures may result in extended diagnostic time, incorrect diagnosis, and incorrect parts replacements.
- Never use electrical test equipment other than that specified in this manual.

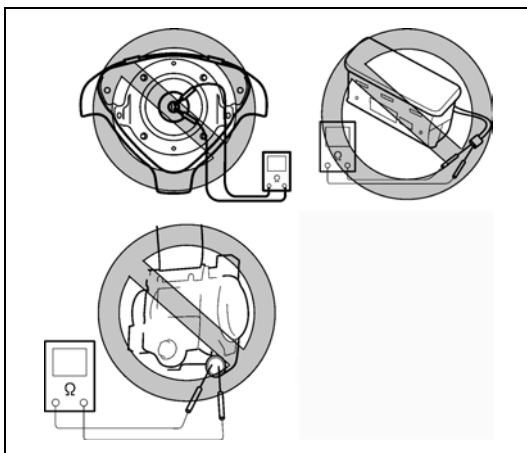

WARNING:

Never attempt to measure the resistance of the air bag (inflator) modules (driver and passenger). It is very dangerous as the electric current from the tester may deploy the air bag or activate the pretensioner.

Service and Handling

WARNING:

Many of service procedures require disconnection of "Air Bag" fuse and all air bag (inflator) module (s) from initiator circuit to avoid an accidental deployment.

Driver and passenger Air Bag (Inflator) Modules

- For handling and storage of a live air bag (inflator) module, select a place where the ambient temperature below 65°C (150°F), without high humidity and away from electric noise.
- When carrying a live air bag (inflator) module, make sure the bag opening is pointed away from you. In case of an accidental deployment, the bag will then deploy with minimal chance of injury. Never carry the air bag (inflator) module by the wires or connector on the underside of the module. When placing a live air bag (inflator) module on a bench or other surface, always face the bag up, away from the surface. As the live passenger air bag (inflator) module must be placed with its bag (trim cover) facing up, place it on the workbench with a slit (1) or use the workbench vise (2) to hold it securely at its lower mounting bracket (3). It is also prohibited to place anything on top of the trim cover and stack air bag (inflator) modules. This is necessary so that a free space is provided to allow the air bag to expand in the unlikely event of accidental deployment. Otherwise, personal injury may result.
- Never dispose of live (undeployed) air bag (inflator) modules (driver and passenger). If disposal is necessary, be sure to deploy them according to deployment procedures described in Section 10B before disposal.
- The air bag (inflator) module immediately after deployment is very hot. Wait for at least half an hour to cool it off before proceeding the work.
- After an air bag (inflator) module has been deployed, the surface of the air bag may contain a powdery residue. This powder consists primarily of cornstarch (used to lubricate the bag as it inflates) and by-products of the chemical reaction. As with many service procedures, gloves and safety glasses should be worn.

[A]

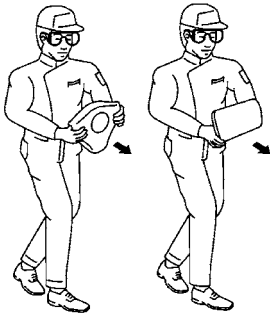

[B]

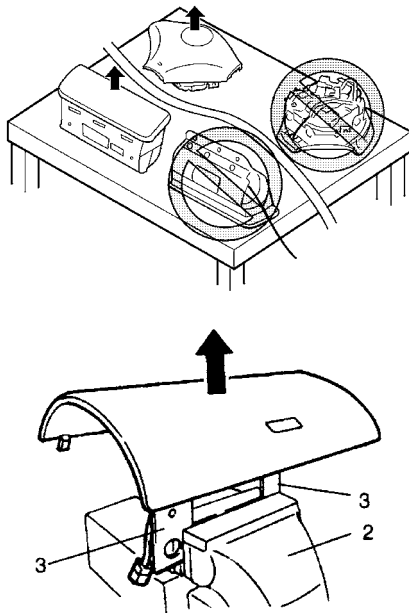

[A]: Always carry air bag (inflator) module with trim cover (air bag opening) away from body.

[B]: Always place air bag (inflator) module on workbench with trim cover (air bag opening) up, away from loose objects.

WARNING:**Sensing and Diagnostic Module (SDM)**

- For handling and storage of a SDM, select a place where the ambient temperature below 65°C (150°F), without high humidity and away from electric noise.
- During service procedures, be very careful when handling a SDM. Never strike or jar the SDM.
- Never power up the air bag system when the SDM is not rigidly attached to the vehicle. All SDM and mounting bracket fasteners must be carefully torqued and the arrow must be pointing toward the front of the vehicle to ensure proper operation of the air bag system.

The SDM could be activated when powered while not rigidly attached to the vehicle which could cause deployment and result in personal injury.

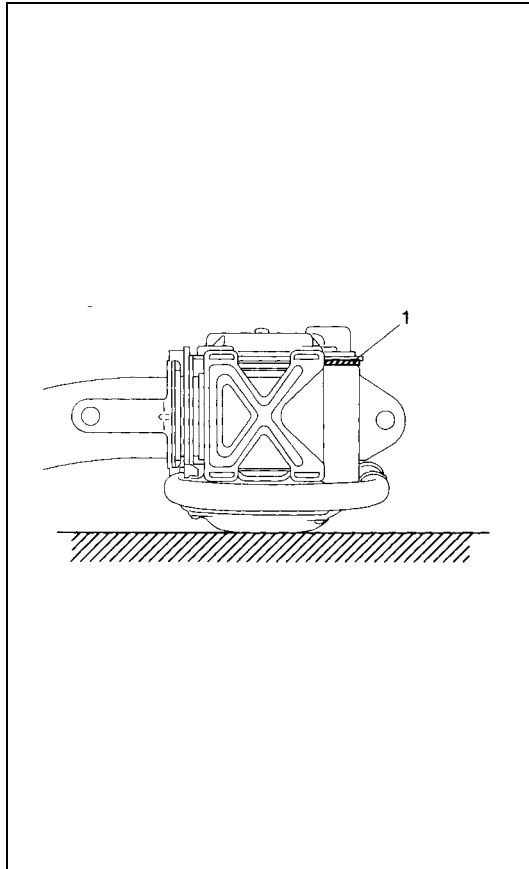
**WARNING:****Driver and Passenger Seat Belt Pretensioner (If equipped)**

- For handling and storage of a live seat belt pretensioner, select a place where the ambient temperature below 65°C (150°F), without high humidity and away from electric noise.
- Never carry seat belt pretensioner by wire or connector of pretensioner. When placing a live seat belt pretensioner on the workbench or some place like that, never put something on seat belt pretensioner. Otherwise, personal injury may result.
- Never dispose of live (inactivated) seat belt pretensioner (driver and passenger). If disposal is necessary, be sure to activate them according to activation procedures described in Section 10B before disposal.
- The seat belt pretensioner immediately after activation is very hot. Wait for at least half an hour to cool it off before proceeding the work.

With many service procedures, gloves and safety glasses should be worn to prevent any possible irritation of the skin or eyes.

- Even when the accident was light enough not to cause air bags to activate, be sure to inspect system parts and other related parts according to instructions under “Repair and Inspection Required After an Accident” in Section 10B.
- When servicing parts other than air bag system, if shocks may be applied to air bag system component parts, remove those parts beforehand.
- When handling the air bag (inflator) modules (driver and passenger), seat belt pretensioner (driver and passenger) or SDM, be careful not to drop it or apply an impact to it. If an excessive impact was applied, never attempt disassembly or repair but replace it with a new one.
- When grease, cleaning agent, oil, water, etc. has got onto air bag (inflator) modules (driver and passenger) or seat belt pretensioner (driver and passenger), wipe off immediately with a dry cloth.
- Air bag wire harness is included in floor and main wire harnesses. Air bag wire harness branched off from floor and main wire harnesses can be identified easily as it is covered with a yellow protection tube and it has yellow connectors. Be very careful when handling it.
- When an open in air bag wire harness, damaged wire harness, connector or terminal is found, replace wire harness, connectors and terminals as an assembly.

- Do not apply power to the air bag system unless all components are connected or a diagnostic chart requests it, as this will set a diagnostic trouble code.
- Never use air bag system component parts from another vehicle.
- When using electric welding, be sure to disconnect all air bag (inflator) module connectors and pretensioner connectors from air bag wire harness respectively.
- Never expose air bag system component parts directly to hot air (drying or baking the vehicle after painting) or flames.
- **WARNING / CAUTION** labels are attached on each part of air bag system components. Be sure to follow the instructions.
- After vehicle is completely repaired, perform “Air Bag Diagnostic System Check” in Section 10B.

General Precautions

The **WARNING** and **CAUTION** below describe some general precautions that you should observe when servicing a vehicle. These general precautions apply to many of the service procedures described in this manual, and they will not necessarily be repeated with each procedure to which they apply.

WARNING:

- Whenever raising a vehicle for service, be sure to follow the instructions under “Vehicle Lifting Points” in this section.
- When it is necessary to do service work with the engine running, make sure that the parking brake is set fully and the transmission is in Neutral (for manual transmission vehicles) or Park (for automatic transmission vehicles). Keep hands, hair, clothing, tools, etc. away from the fan and belts when the engine is running
- When it is necessary to run the engine indoors, make sure that the exhaust gas is forced outdoors.
- Do not perform service work in areas where combustible materials can come in contact with a hot exhaust system. When working with toxic or flammable materials (such as gasoline and refrigerant), make sure that the area you work in is well-ventilated.
- To avoid getting burned, keep away from hot metal parts such as the radiator, exhaust manifold, tailpipe, muffler, etc.
- New and used engine oil can be hazardous. Children and pets may be harmed by swallowing new or used oil. Keep new and used oil and used engine oil filters away from children and pets. Continuous contact with used engine oil has been found to cause [skin] cancer in laboratory animals. Brief contact with used oil may irritate skin. To minimize your exposure to used engine oil, wear a long-sleeve shirt and moisture-proof gloves (such as dish washing gloves) when changing engine oil. If engine oil contacts your skin, wash thoroughly with soap and water. Launder any clothing or rags if wet with oil, recycle or properly dispose of used oil and filters.
- Make sure the bonnet is fully closed and latched before driving. If it is not, it can fly up unexpectedly during driving, obstructing your view and resulting in an accident.

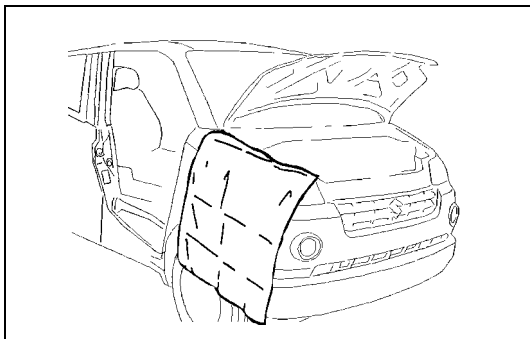

- Before starting any service work, cover fenders, seats and any other parts that are likely to get scratched or stained during servicing. Also, be aware that what you wear (e.g, buttons) may cause damage to the vehicle's finish.

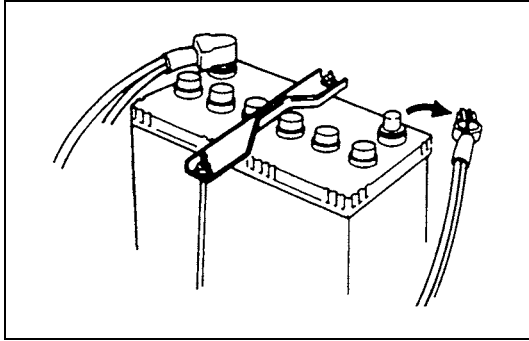

- When performing service to electrical parts that does not require use of battery power, disconnect the negative cable of the battery.
- Before disconnecting the negative cable from battery, record display of the clock and/or audio system (if equipped), and reset it as before after connecting.

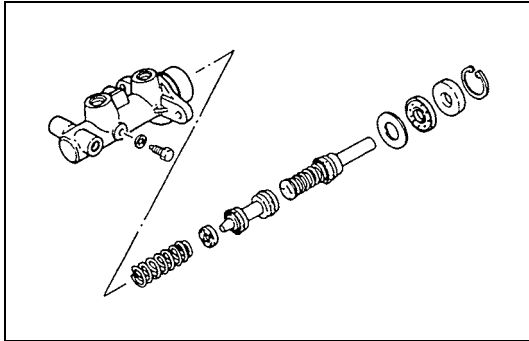

- When removing parts that are to be reused, be sure to keep them arranged in an orderly manner so that they may be reinstalled in the proper order and position.

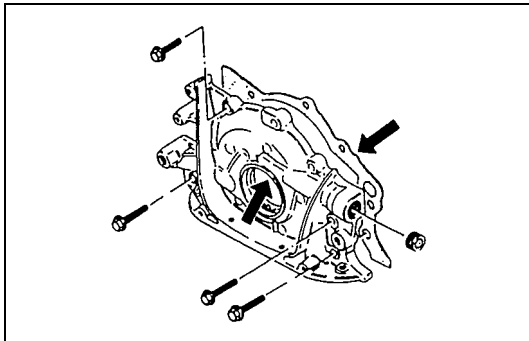

- Whenever you use oil seals, gaskets, packing, O-rings, locking washers, split pins, self-locking nuts, and certain other parts as specified, be sure to use new ones. Also, before installing new gaskets, packing, etc., be sure to remove any residual material from the mating surfaces.

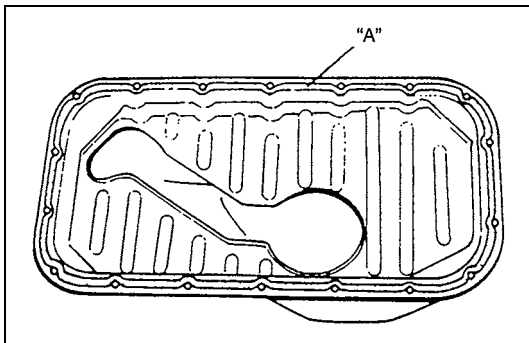

- Make sure that all parts used in reassembly are perfectly clean.
- When use of a certain type of lubricant, bond or sealant is specified, be sure to use the specified type.

“A”: Sealant 99000-31150

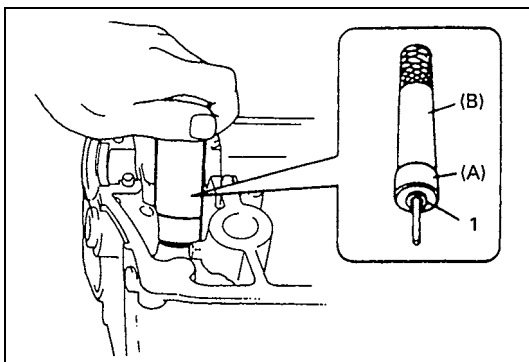

- Be sure to use special tools when instructed.

Special tool

(A): 09917-98221

(B): 09916-58210

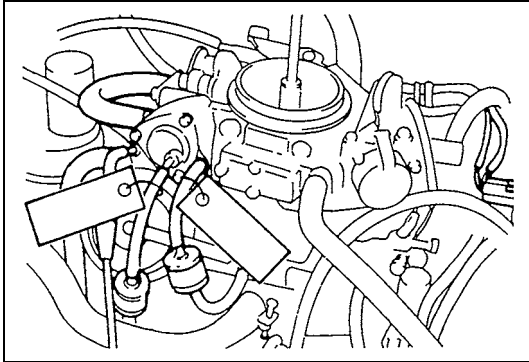

- When disconnecting vacuum hoses, attach a tag describing the correct installation positions so that the hoses can be reinstalled correctly.

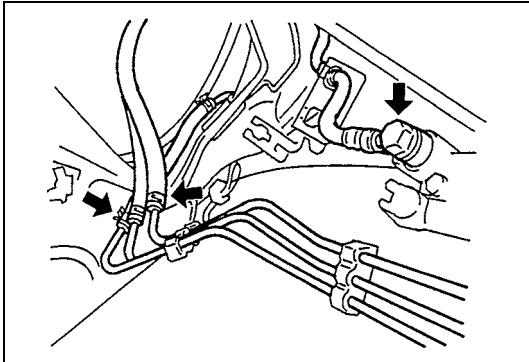

- After servicing fuel, oil, coolant, vacuum, exhaust or brake systems, check all lines related to the system for leaks.
- For vehicles equipped with fuel injection systems, never disconnect the fuel line between the fuel pump and injector without first releasing the fuel pressure, or fuel can be sprayed out under pressure.

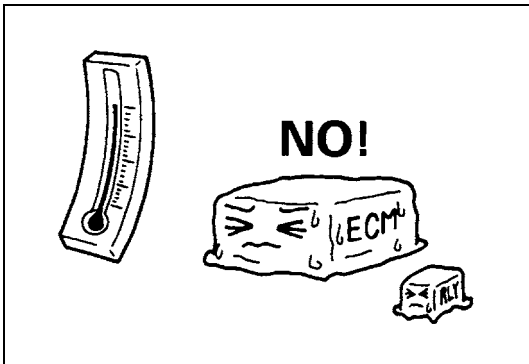

- When performing a work that produces a heat exceeding 80°C (176°F) in the vicinity of the electrical parts, remove the heat sensitive electrical part(s) beforehand.

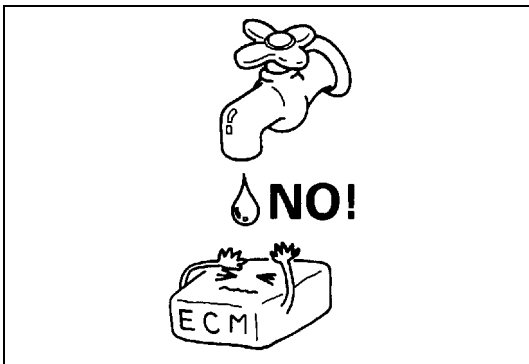

- Use care not to expose connectors and electrical parts to water which will be a cause of a trouble.

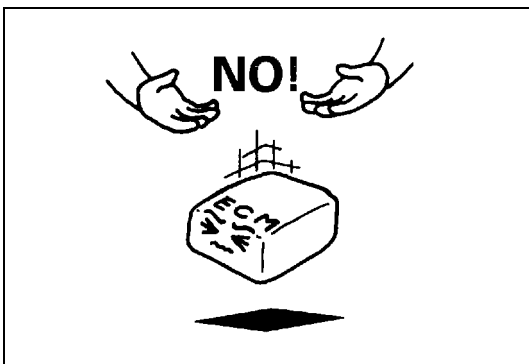

- Always be careful not to handle electrical parts (computer, relay, etc.) in a rough manner or drop them.

Precautions for Catalytic Converter

For vehicles equipped with a catalytic converter, use only unleaded gasoline and be careful not to let a large amount of unburned gasoline enter the converter or it can be damaged.

- Conduct a spark jump test only when necessary, make it as short as possible, and do not open the throttle.
- Conduct engine compression checks within the shortest possible time.
- Avoid situations which can result in engine misfire (e.g. starting the engine when the fuel tank is nearly empty.)

Precaution for Installing Mobile Communication Equipment

When installing mobile communication equipment such as CB (Citizens-Band) -radio or cellular-telephone, be sure to observe the following precautions.

Failure to follow cautions may adversely affect electronic control system.

- Keep the antenna as far away as possible from the vehicle's electronic control unit.
- Keep the antenna feeder more than 20 cm (7.9 in) away from electronic control unit and its wire harnesses.
- Do not run the antenna feeder parallel with other wire harnesses.
- Confirm that the antenna and feeder are correctly adjusted.

Precautions for Vehicle Hooks

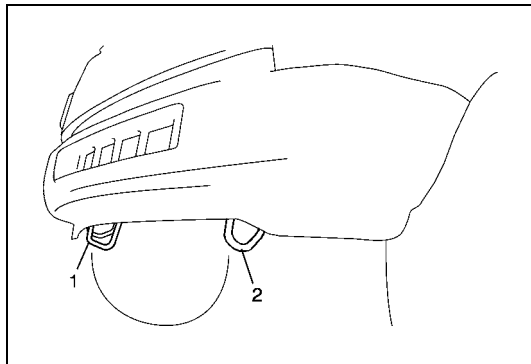

Never use hook (2) to tow (or to be towed by) another vehicle on the road or highway or body may be deformed.

Use hook (1) for towing purpose.

When vehicle is shipped by sea and land, use hooks (1) and (2) to tie-down vehicle.

Precautions for Electrical Circuit Service

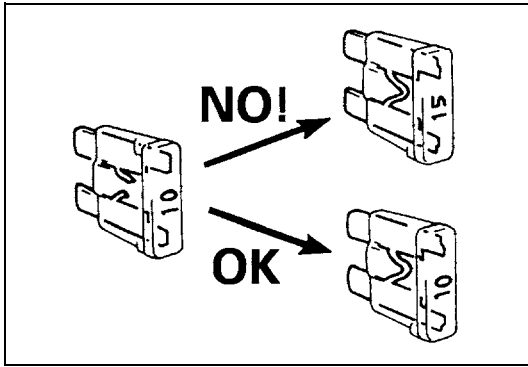

- When replacing a fuse, make sure to use a fuse of the specified capacity. Use of a fuse with a larger capacity will cause a damage to the electrical parts and a fire.

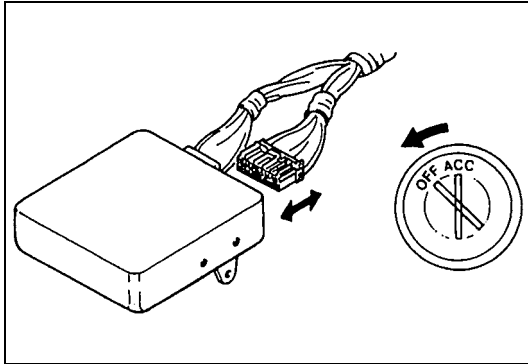

- When disconnecting and connecting coupler, make sure to turn ignition switch OFF, or electronic parts may get damaged.

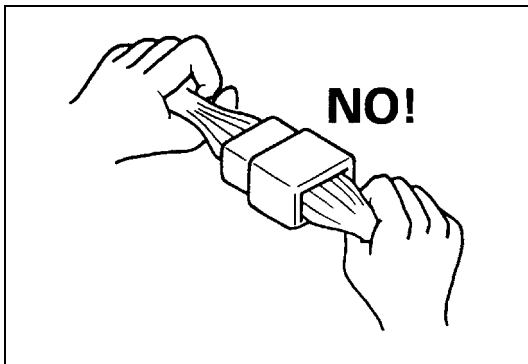

- When disconnecting connector, never pull the wiring harness. Unlock the connector lock first and then pull them apart by holding connectors themselves

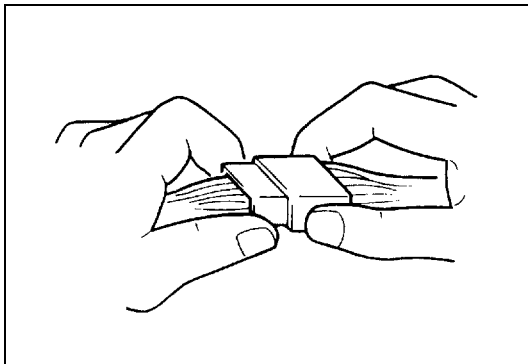

- When connecting connectors, also hold connectors and put them together until they lock securely (a click is heard).

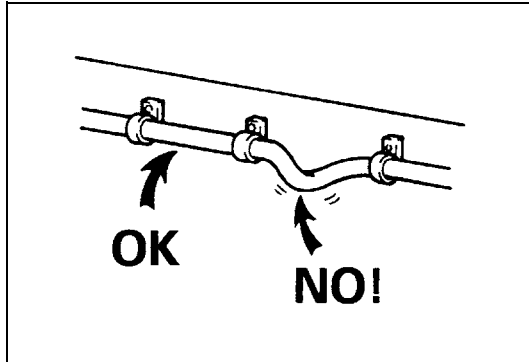

- When installing the wiring harness, fix it with clamps so that no slack is left.

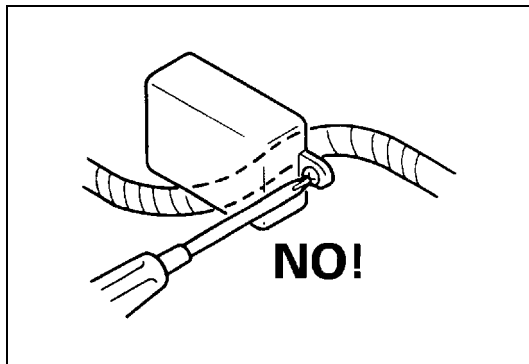

- When installing vehicle parts, be careful so that the wiring harness is not interfered with or caught by any other part.

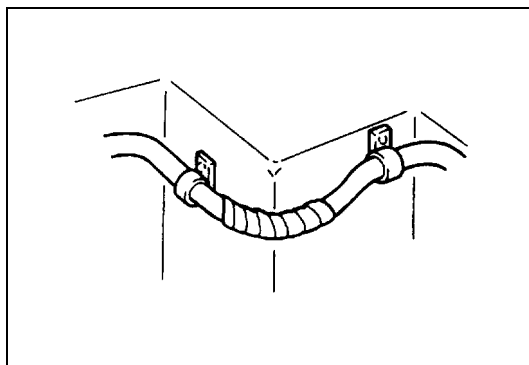

- To avoid damage to the harness, protect its part which may contact against a part forming a sharp angle by winding tape or the like around it.

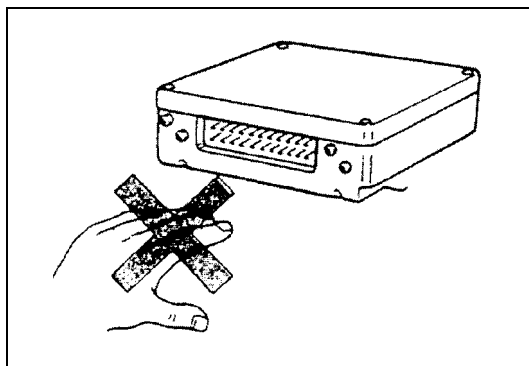

- Be careful not to touch the electrical terminals of parts which use microcomputers (e.g. electronic control unit like as ECM, PCM, P/S controller, etc.). The static electricity from your body can damage these parts.
- Never connect any tester (voltmeter, ohmmeter, or whatever) to electronic control unit when its coupler is disconnected. Attempt to do it may cause damage to it.
- Never connect an ohmmeter to electronic control unit with its coupler connected to it. Attempt to do it may cause damage to electronic control unit and sensors.
- Be sure to use a specified voltmeter/ohmmeter. Otherwise, accurate measurements may not be obtained or personal injury may result. If not specified, use a voltmeter with high impedance ($M \Omega/V$ minimum) or a digital type voltmeter.

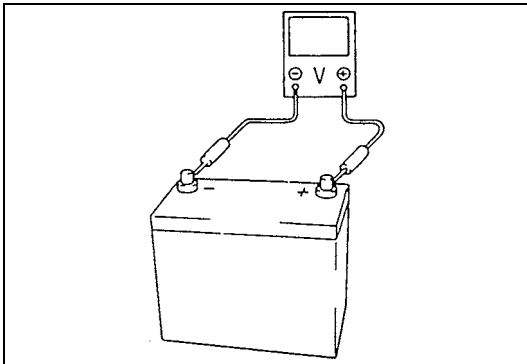
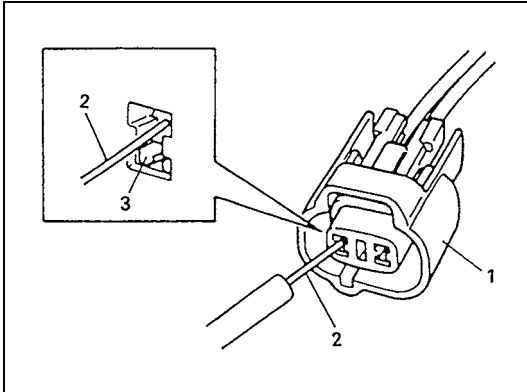
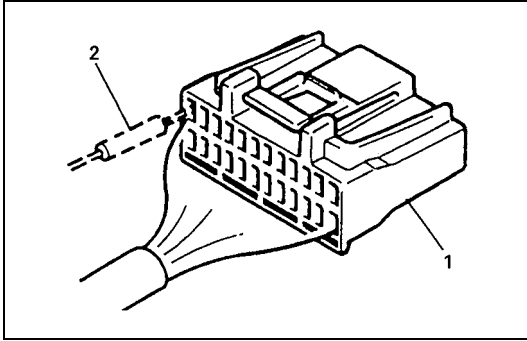

- When taking measurements at electrical connectors using a tester probe, be sure to insert the probe (2) from the wire harness side (backside) of the connector (1).
- When connecting meter probe (2) from terminal side of coupler (1) because it can't be connected from harness side, use extra care not to bend male terminal of coupler or force its female terminal open for connection. In case of such coupler as shown connect probe as shown to avoid opening female terminal. Never connect probe where male terminal is supposed to fit (3).
- When checking connection of terminals, check its male half for bend and female half for excessive opening and both for locking (looseness), corrosion, dust, etc.
- Before measuring voltage at each terminal, check to make sure that battery voltage is 11 V or higher. Such terminal voltage check at low battery voltage will lead to erroneous diagnosis.

Electrical Circuit Inspection Procedure

While there are various electrical circuit inspection methods, described here is a general method to check its open and short circuit by using an ohmmeter and a voltmeter.

Open Circuit Check

Possible causes for the open circuit are as follows. As the cause is in the connector or terminal in many cases, they need to be checked particularly carefully.

- Loose connection of connector
- Poor contact of terminal (due to dirt, corrosion or rust on it, poor contact tension, entry of foreign object etc.)
- Wire harness being open

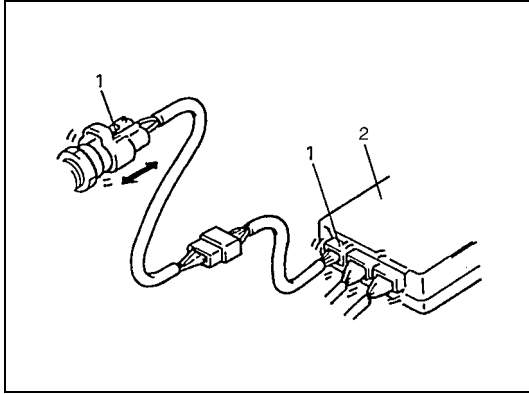

When checking system circuits including an electronic control unit such as ECM (2), TCM, ABS control module, etc., it is important to perform careful check, starting with items which are easier to check.

- 1) Disconnect negative cable from battery.
- 2) Check each connector at both ends of the circuit being checked for loose connection (1). Also check lock condition of connector if equipped with connector lock.

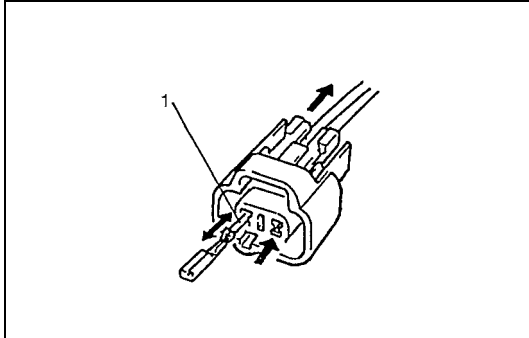

- 3) Using a test male terminal, check both terminals of the circuit being checked for contact tension of its female terminal. Check each terminal visually for poor contact (possibly caused by dirt, corrosion, rust entry of foreign object, etc.). At the same time, check to make sure that each terminal is locked in the connector fully.

1. Check contact tension by Inserting and removing just for once
--

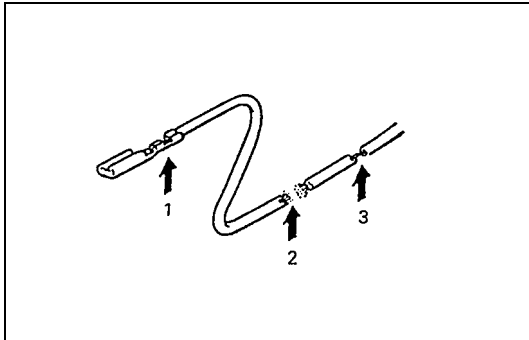

- 4) Using continuity check or voltage check procedure described in the following page, check the wire harness for open circuit and poor connection with its terminals. Locate abnormality, if any.

1. Looseness of crimping
2. Open
3. Thin wire (single strand of wire)

Continuity Check

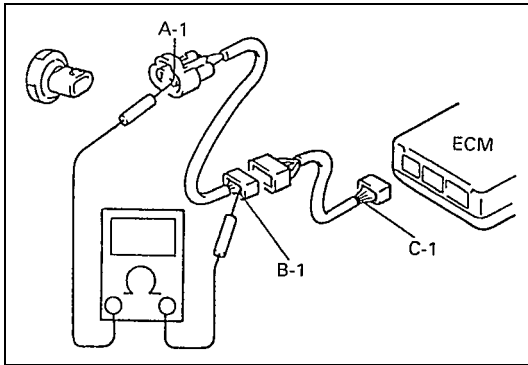

- 1) Measure resistance between connector terminals at both ends of the circuit being checked (between A-1 and C-1 in the figure).

If no continuity is indicated (infinity or over limit), that means that the circuit is open between terminals A-1 and C-1.

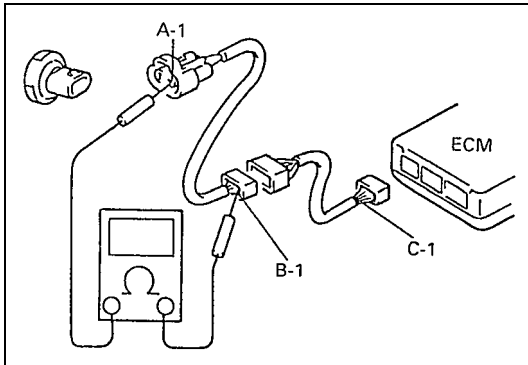

- 2) Disconnect the connector included in the circuit (connector-B in the figure) and measure resistance between terminals A-1 and B-1.

If no continuity is indicated, that means that the circuit is open between terminals A-1 and B-1. If continuity is indicated, there is an open circuit between terminals B-1 and C-1 or an abnormality in connector-B.

Voltage check

If voltage is supplied to the circuit being checked, voltage check can be used as circuit check.

- 1) With all connectors connected and voltage applied to the circuit being checked, measure voltage between each terminal and body ground.

- a) If measurements were taken as shown in the figure at the left and results were as listed below, it means that the circuit is open between terminals B-1 and A-1.

Voltage Between:

C-1 and body ground: Approx. 5V

B-1 and body ground: Approx. 5V

A-1 and body ground: 0V

- b) Also, if measured values were as listed below, it means that there is a resistance (abnormality) of such level that corresponds to the voltage drop in the circuit between terminals A-1 and B-1.

Voltage Between:

C-1 and body ground: Approx. 5V

B-1 and body ground: Approx. 5V

A-1 and body ground: Approx. 3V (2V voltage drop)

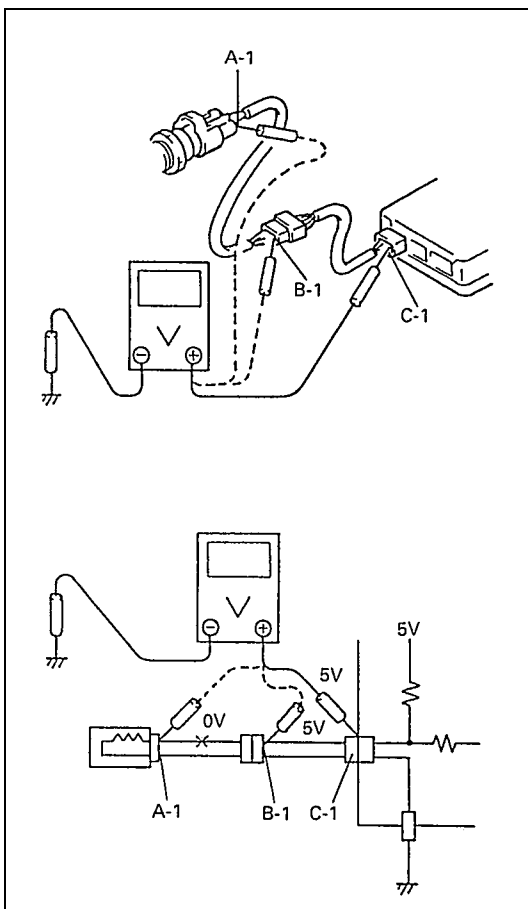

Short Circuit Check (Wire Harness to Ground)

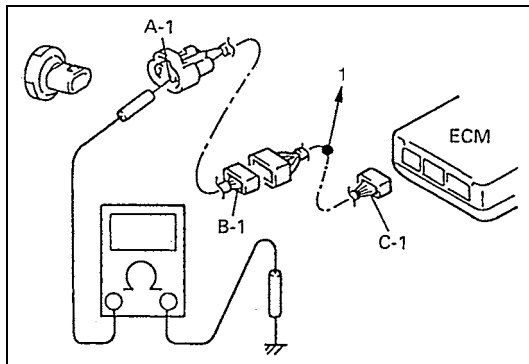
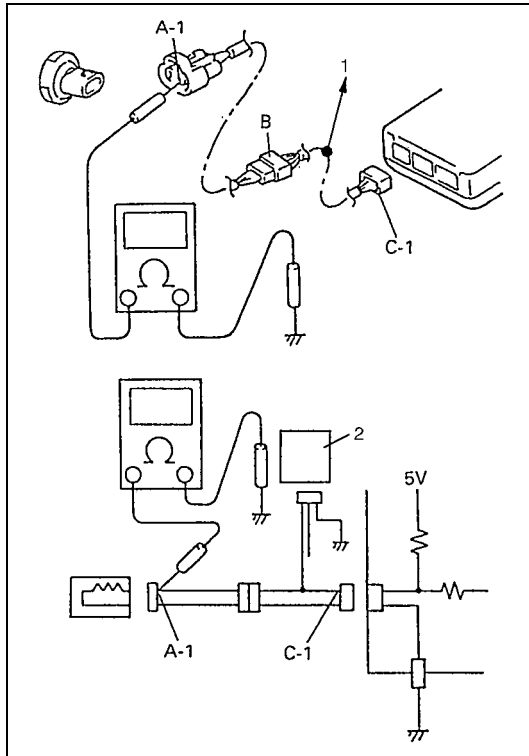

- 1) Disconnect negative cable from battery.
- 2) Disconnect connectors at both ends of the circuit to be checked.

NOTE:

If the circuit to be checked is connected to other parts (1), disconnect all connectors of those parts. Otherwise, diagnosis will be misled.

- 3) Measure resistance between terminal at one end of circuit (A-1 terminal in figure) and body ground. If continuity is indicated, it means that there is a short to ground between terminals A-1 and C-1 of the circuit.

2. Other parts

- 4) Disconnect the connector included in circuit (connector B) and measure resistance between A-1 and body ground. If continuity is indicated, it means that the circuit is shorted to the ground between terminals A-1 and B-1.

1. To other parts

Intermittent and Poor Connection

Most intermittent are caused by faulty electrical connections or wiring, although a sticking relay or solenoid can occasionally be at fault. When checking it for proper connection, perform careful check of suspect circuits for:

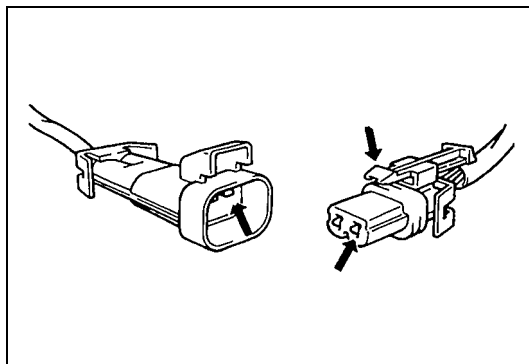

- Poor mating of connector halves, or terminals not fully seated in the connector body (backed out).
- Dirt or corrosion on the terminals. The terminals must be clean and free of any foreign material which could impede proper terminal contact. However, cleaning the terminal with a sand paper or the like is prohibited.
- Damaged connector body, exposing the terminals to moisture and dirt, as well as not maintaining proper terminal orientation with the component or mating connector.

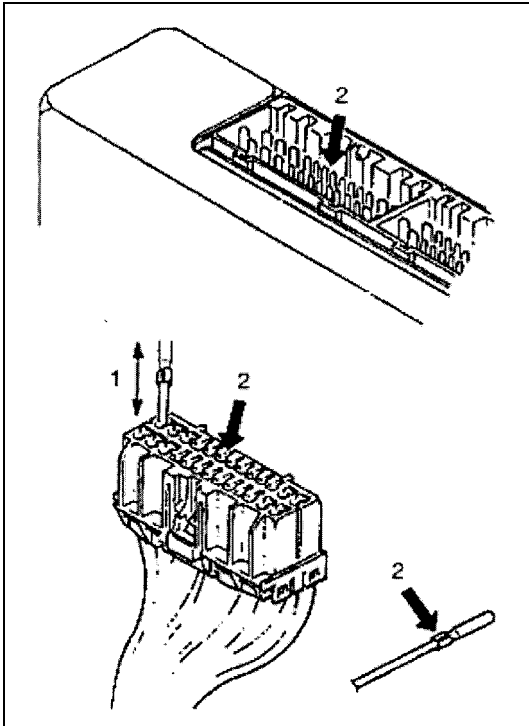

- Improperly formed or damaged terminals.
Check each connector terminal in problem circuits carefully to ensure good contact tension by using the corresponding mating terminal.
If contact tension is not enough, reform it to increase contact tension or replace.

1. Check contact tension by inserting and removing just once.
2. Check each terminal for bend and proper alignment.

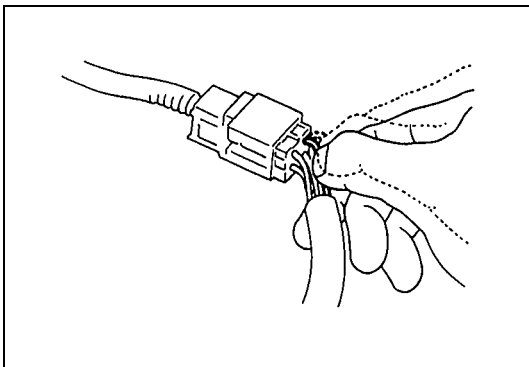

- Poor terminal-to-wire connection.
Check each wire harness in problem circuits for poor connection by shaking it by hand lightly. If any abnormal condition is found, repair or replace.

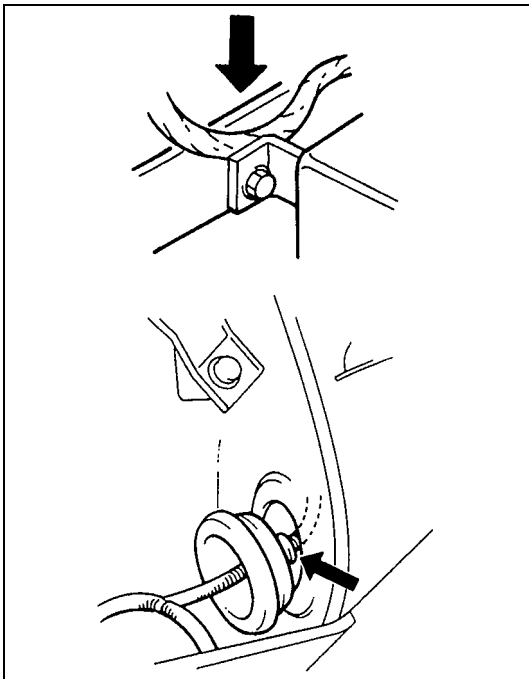

- Wire insulation which is rubbed through, causing an intermittent short as the bare area touches other wiring or parts of the vehicle.
- Wiring broken inside the insulation. This condition could cause continuity check to show a good circuit, but if only 1 or 2 strands of a multi-strand-type wire are intact, resistance could be far too high.
If any abnormality is found, repair or replace.

Identification Information

Vehicle Identification Number

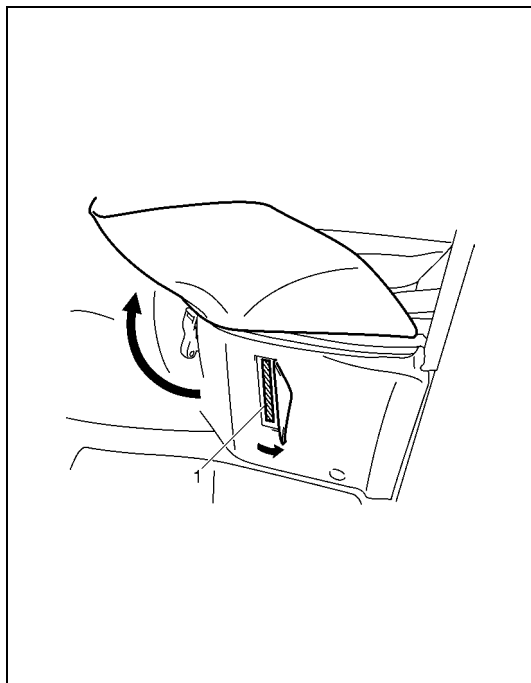

The vehicle identification number (1) is punched on the side surface of the engine room left side panel, located under seat as shown in figure.

Engine Identification Number

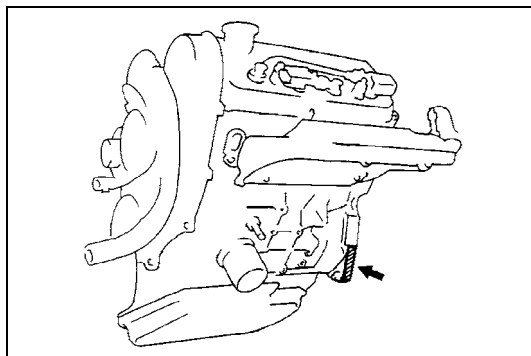

The number is punched on the cylinder block.

Transmission Identification Number

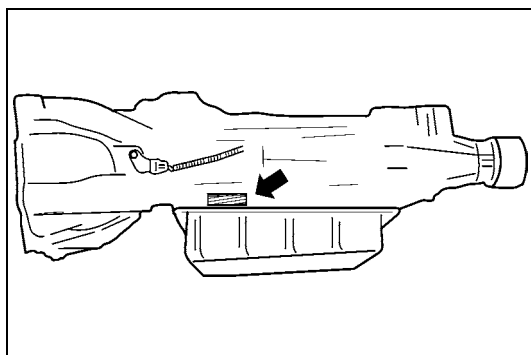

The automatic transmission identification number is located on transmission case.