

Vehicle type	Engine		Clutch type	Type of manual gearbox and automatic transmission
	Type	Capacity		
BA0E	E7J	1390	180 DST 3050 180 CP 3300	JB1
BA0F BA0L	K7M	1598	200 HR 4000	JB1
BA0G	F3R	1998	215 HRN 4000	JB3
BA0A BA0U	F8Q	1870	200 HRV 4600 200 HRV 3100	JB1
BA0F	K7M	1598		AD4

VEHICLE IDENTIFICATION

Example : BA0E

- B : Body type (example 5 door hatchback)
- A : Project code (example 64)
- 0E : Engine suffix (example E7J 764)

LOCATION OF THE VEHICLE IDENTIFICATION PLATE

Two possible locations on the vehicle:

- in the engine compartment (A),

- near to the emergency spare wheel (B) with a duplicate label of the oval plate on the lower part of the passenger door (C).

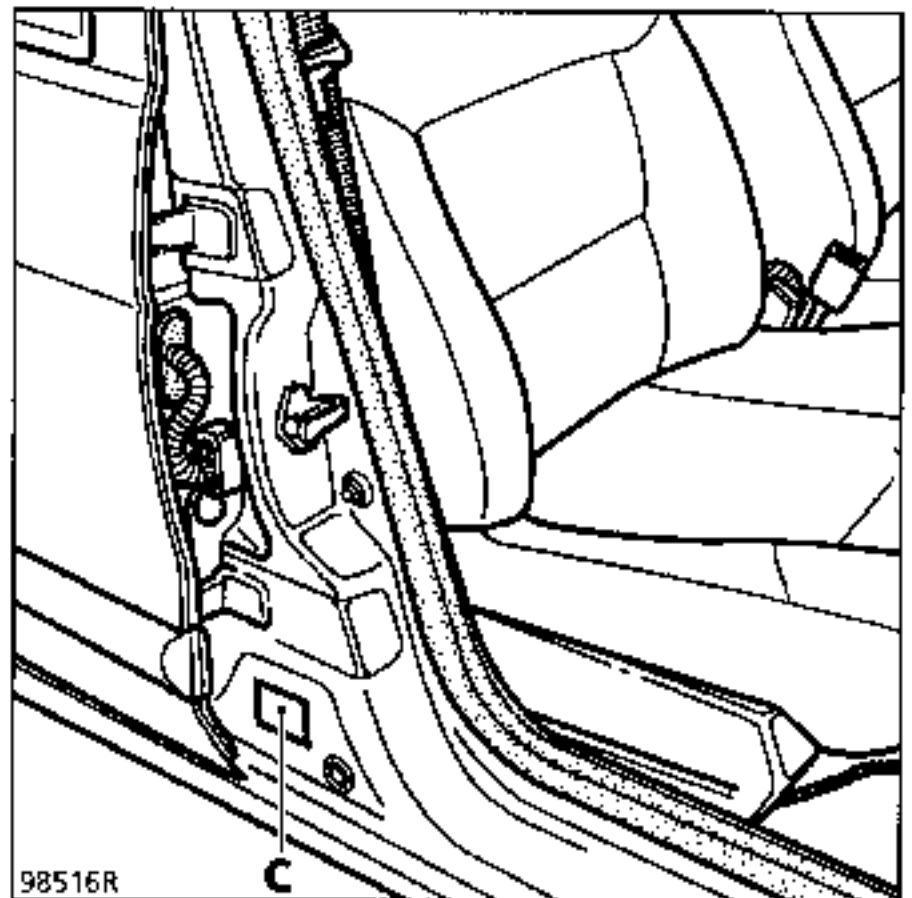
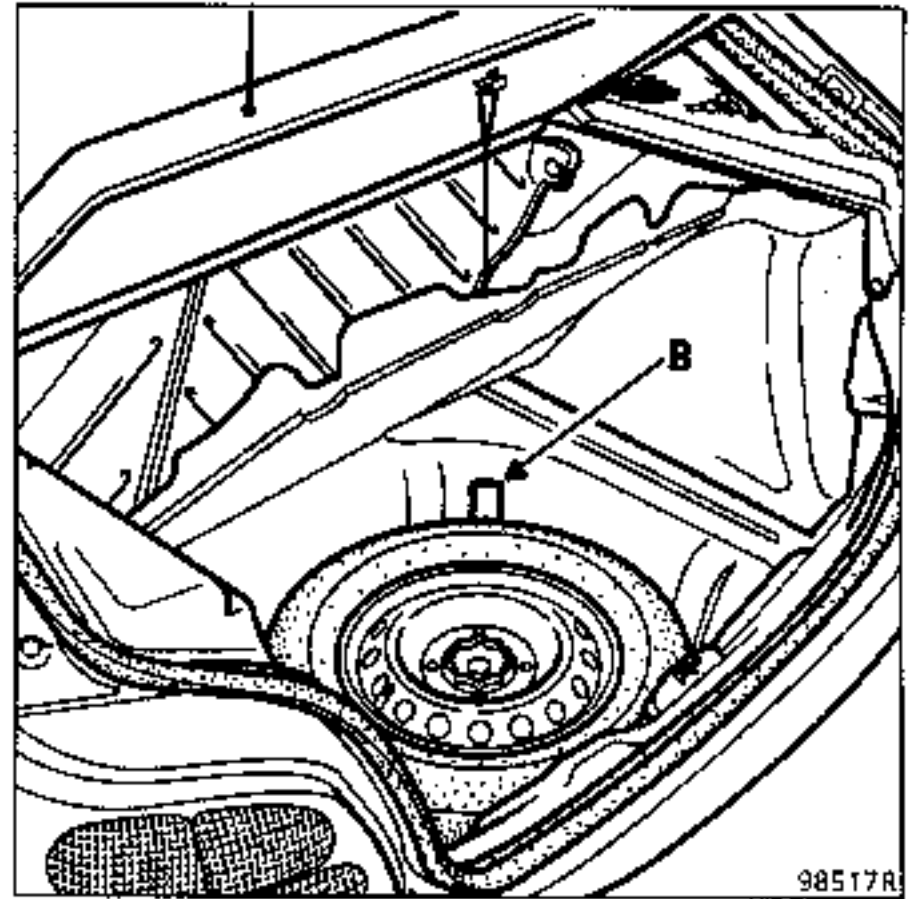
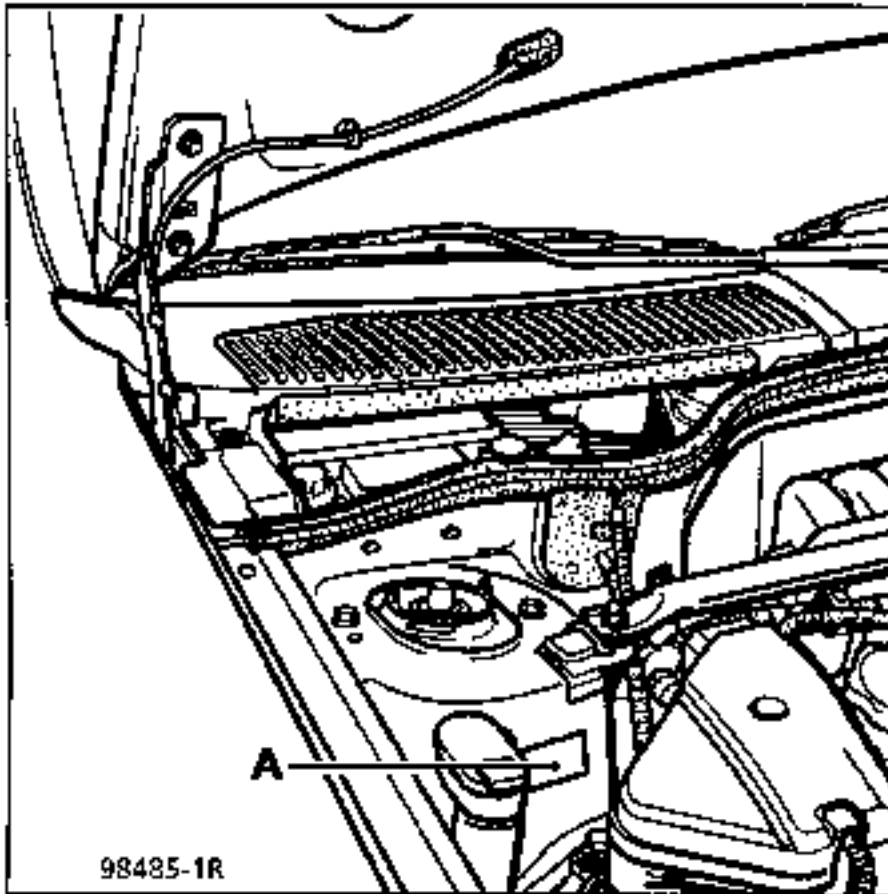

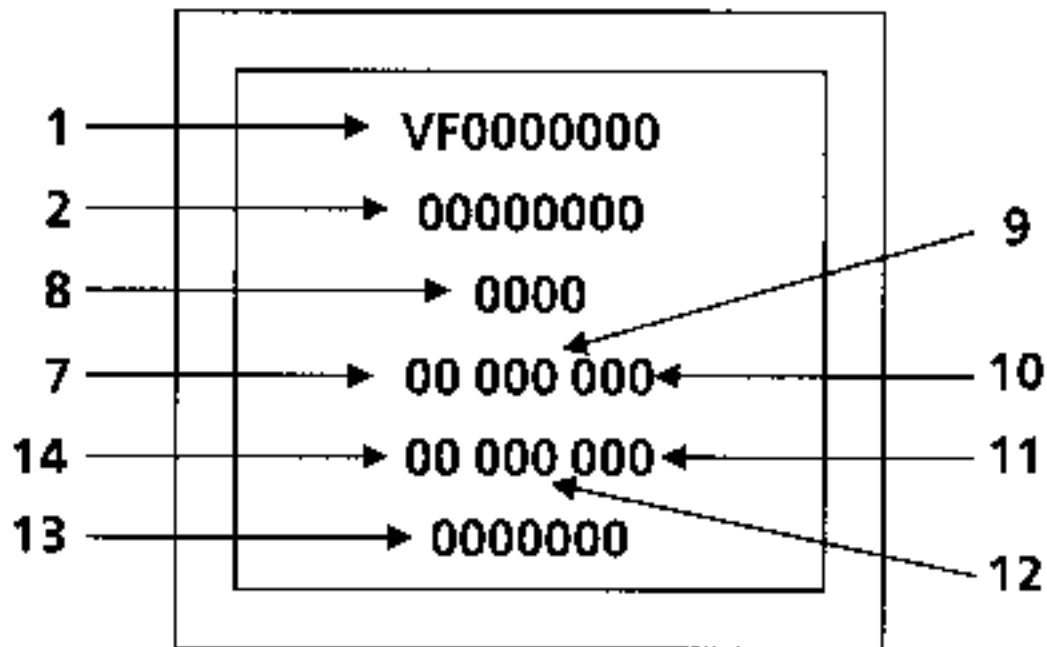
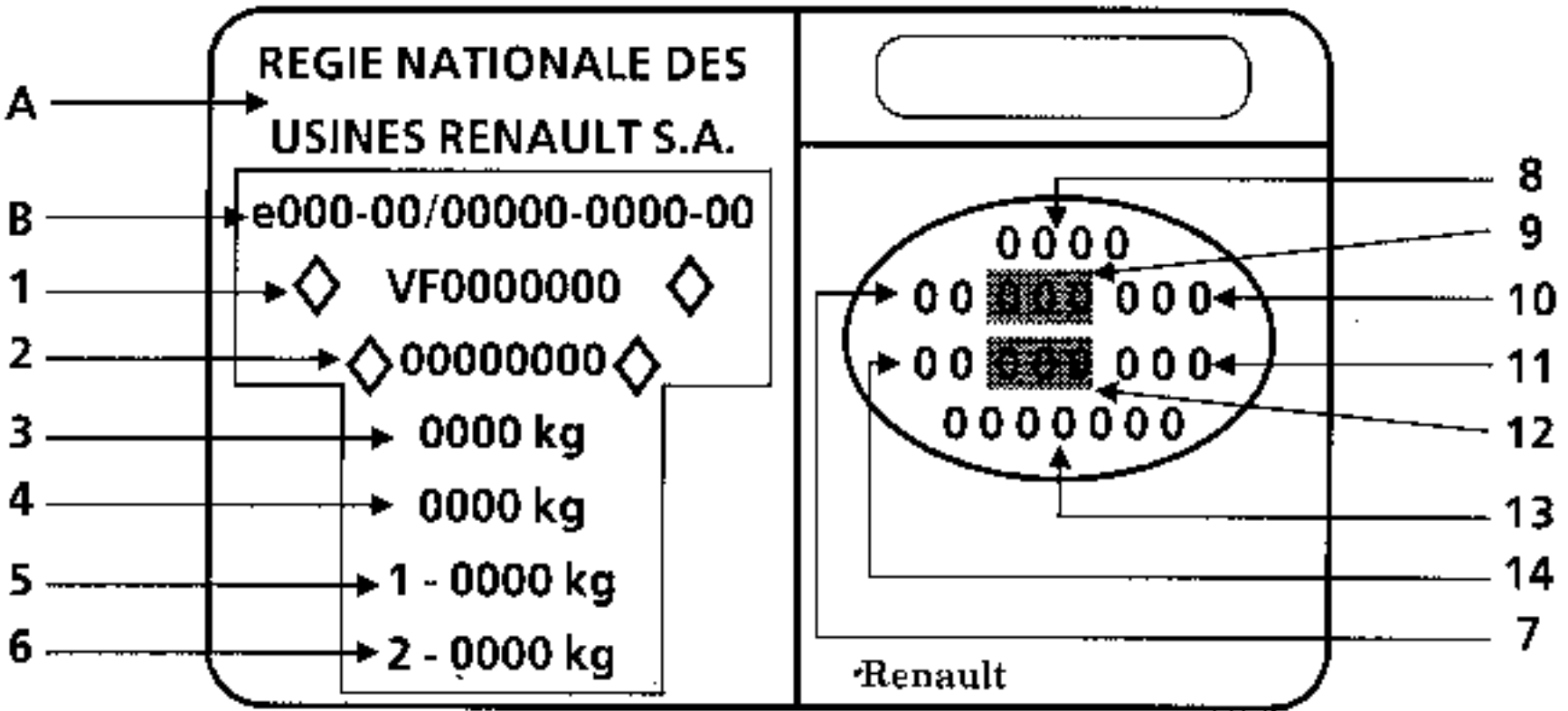

It shows:

- At **A** : the name of the manufacturer,
- At **B** : the E.E.C. acceptance number
- At **1** : the type mines of the vehicle preceded by the world manufacturers identification code (VF1 corresponds to RENAULT FRANCE),
- At **2** : the chassis number,
- At **3** : the total all up weight,
- At **4** : the maximum permitted total train weight,
- At **5** : the maximum permitted weight on the front axle,
- At **6** : the maximum permitted weight on the rear axle,
- At **7** : the first figure indicates the gearbox or factory options, the second figure indicates the equipment level,
- At **8** : the vehicle type,
- At **9** : the technical equipment code,
- At **10** : additional factory optional equipment,
- At **11** : the equipment level,
- At **12** : the paint code,
- At **13** : a letter describing the factory of manufacture followed by the fabrication number,
- At **14** : the trim code.

NOTE : Depending on the country of export, certain details might not be given. The plate described above shows all possible information.

ALLOCATION OF TECHNICAL EQUIPMENT CODES

The equipment code, the three letters which appear in (9), must be documented for vehicle identification reasons (ordering spare parts, warranty claim, etc.)

 Safety symbol (special precautions to be taken when carrying out operations).

SPECIAL TOOLING REQUIRED	
Cha. 280-02	Adaptable cross piece for trolley jack
Cha. 408-01	Adaptable socket for trolley jack
Cha. 408-02	

 If a trolley jack is used, appropriate axle stands must always be used.

It is **forbidden** to lift the vehicle by supporting its weight under the front suspension arm or under the V shaped part of the rear axle.

Depending on the type of trolley jack, use sockets **Cha. 408-01** or **Cha. 408-02** to position the cross piece **Cha. 280-02**.

To lift the front or rear, support the vehicle's weight under the vehicle's jacking points.

TROLLEY JACK USED FROM THE SIDE

Use cross piece **Cha. 280-02**.

Take the weight under the sill, level with the front door.

Position the flange correctly in the groove of the cross piece.

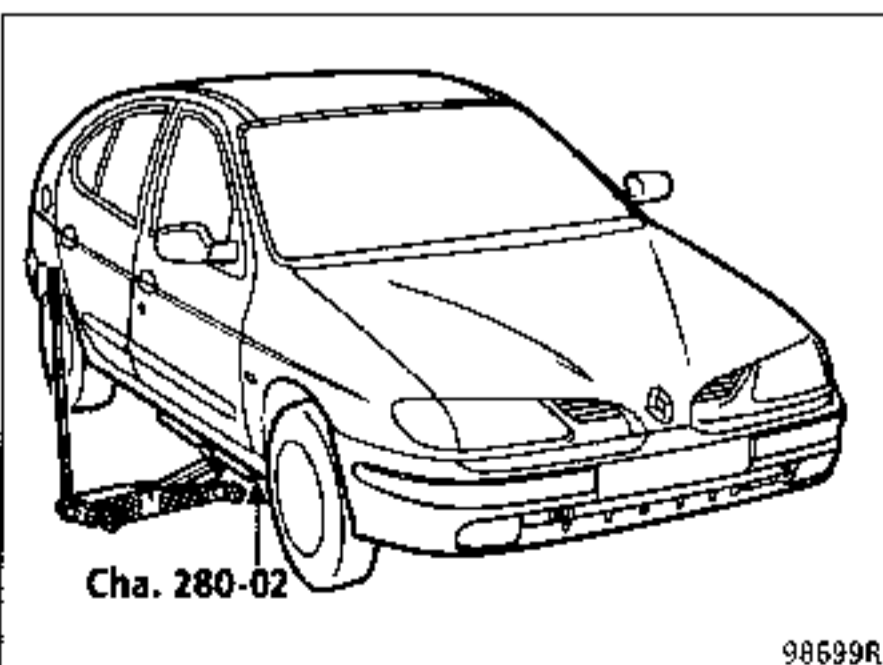

AXLE STANDS

When putting the vehicle on axle stands, they must be positioned:

- either under the reinforcements designed for lifting the vehicle using the vehicle's jack,
- or under the points located behind the reinforcements.

Axle stands are positioned at the rear when the vehicle is lifted from the side.

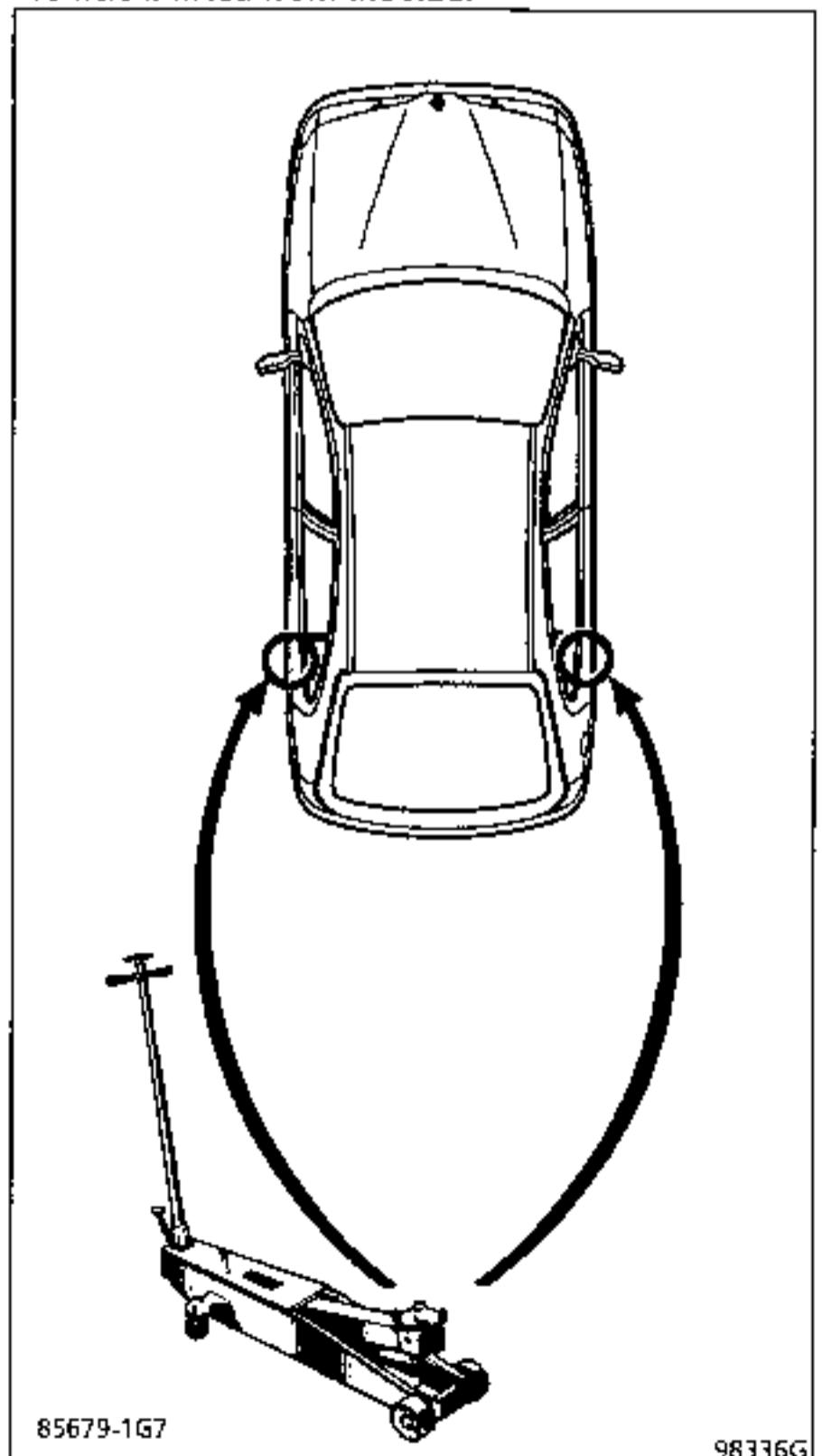

SAFETY INSTRUCTIONS



Several scenarios should be considered:

1 - WHEN REMOVING COMPONENTS

In general, never use a 2 post lift, if a four post lift can be used.

If this is not possible, position the lifting pads under the body sill, level with the vehicle's jacking points.

FRONT

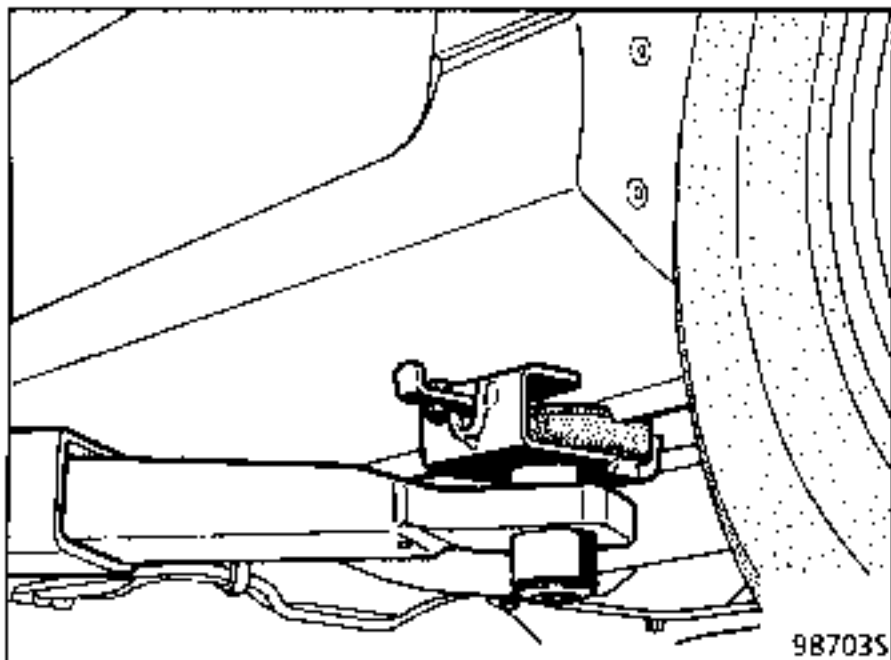

REAR

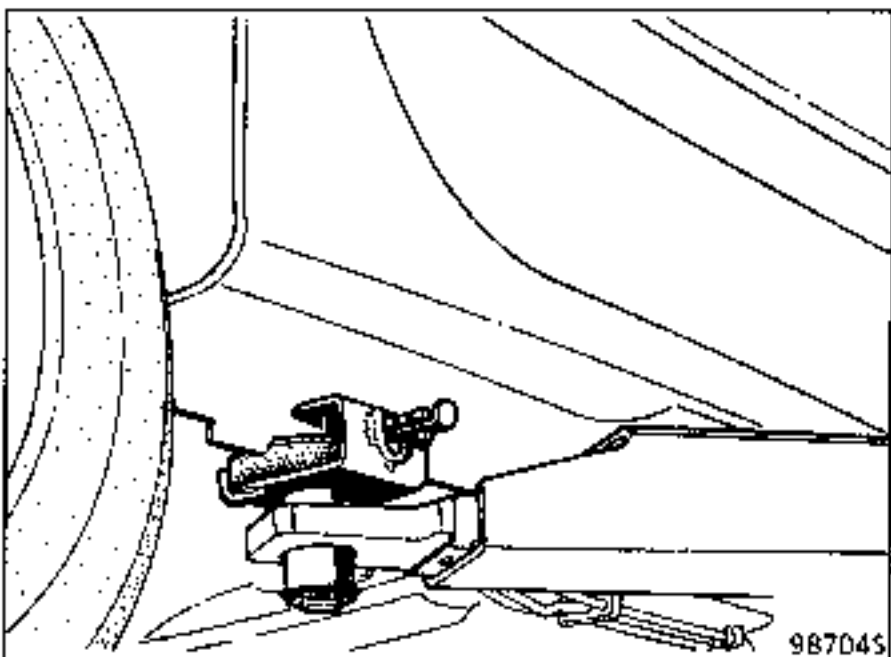

These must be positioned in line with the vehicle's jacking points. They must be clipped into the holes in the body sill.

2 - SPECIFIC CASE OF REMOVING AND REFITTING THE ENGINE AND TRANSMISSION ASSEMBLY

In this specific case, the body of the vehicle must be firmly attached to the arms of the two post lift using the special pads.

FOG

Reference FOG 449 8111 - 449 8411

or

CHEMICO

Reference 39 2550 0001

or

SCENCH

Reference 776 684

OBSERVE THE LEGAL TOWING REQUIREMENTS OF THE COUNTRY YOU ARE IN.

NEVER USE THE DRIVESHAFTS AS ATTACHMENT POINTS.

The towing points may only be used for towing the vehicle on the road. They should never be used for removing the vehicle from a ditch or for any other similar breakdown operation or to lift the vehicle, either directly or indirectly.

FRONT

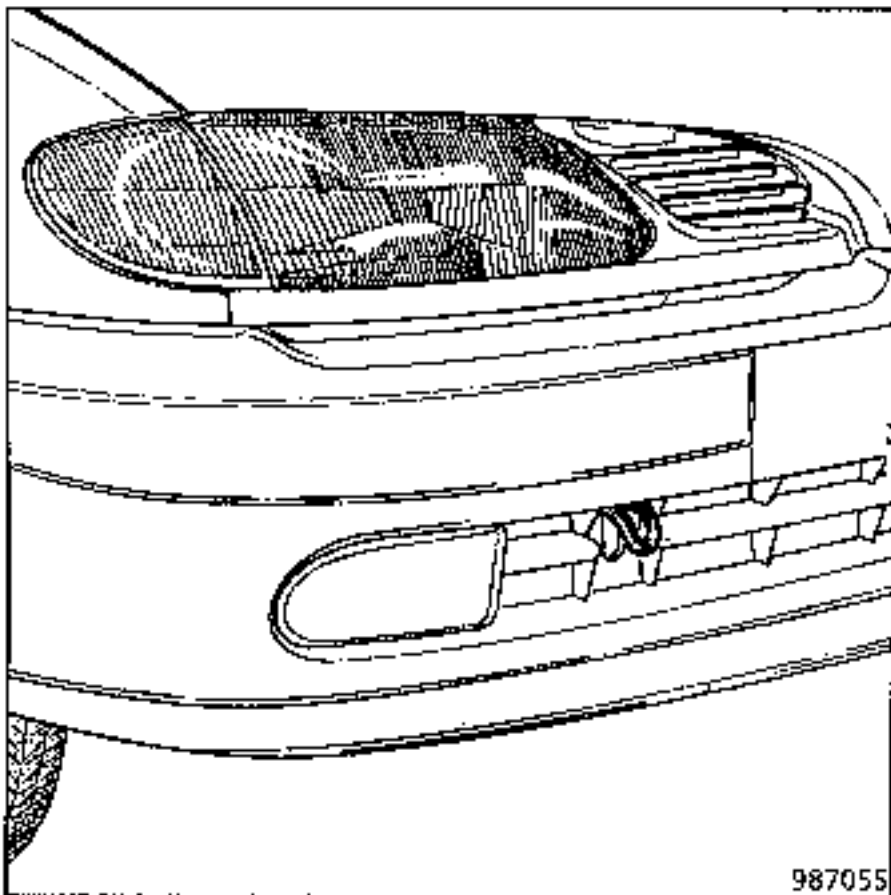

REAR

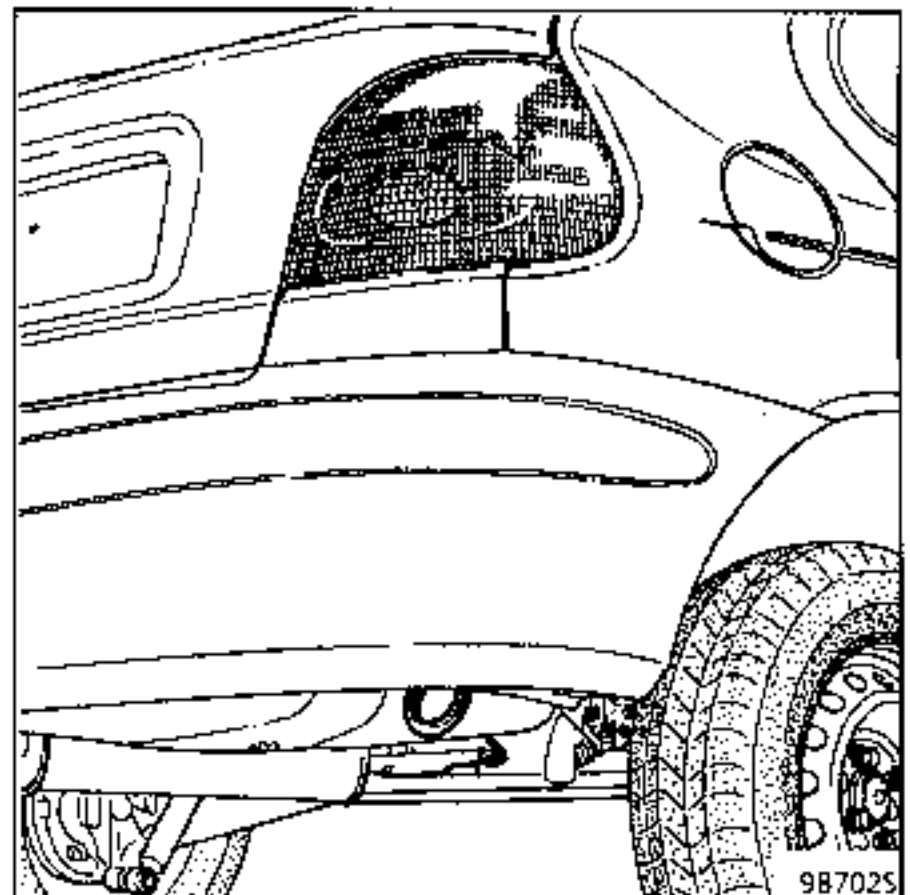

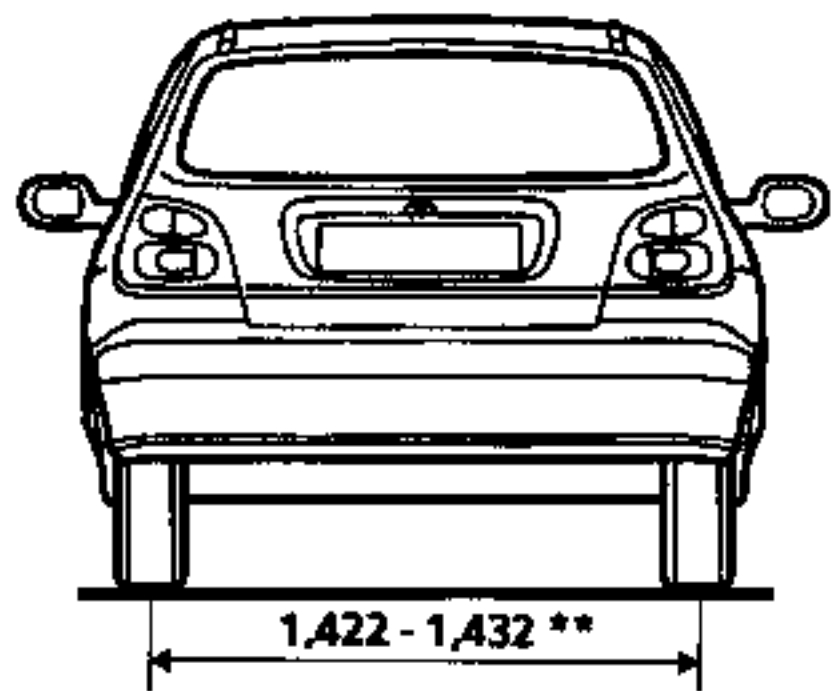
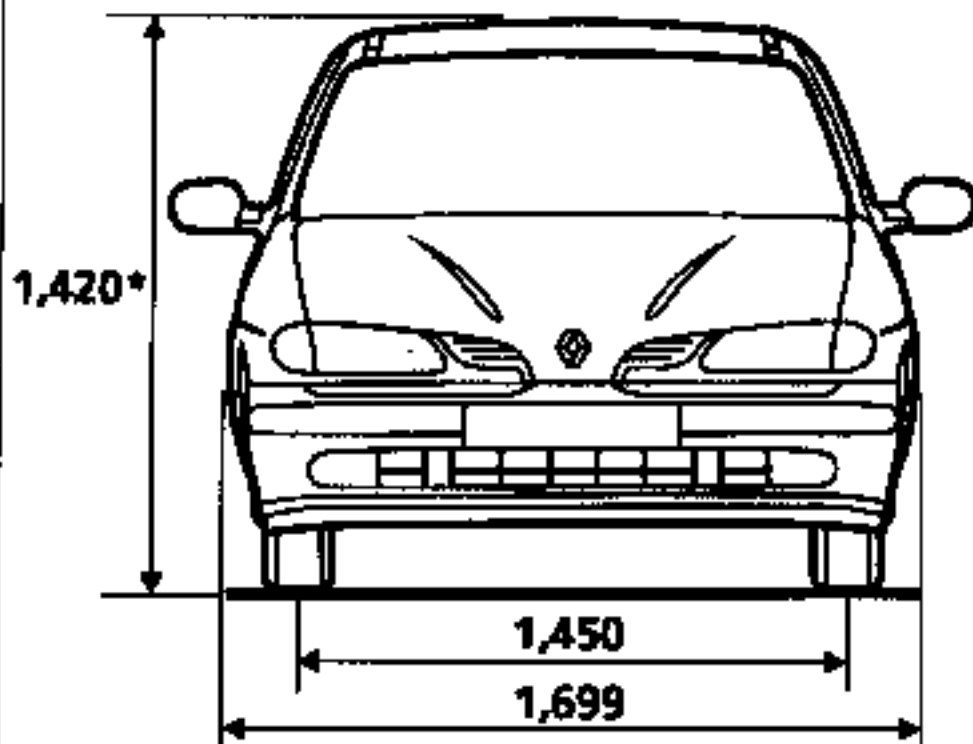
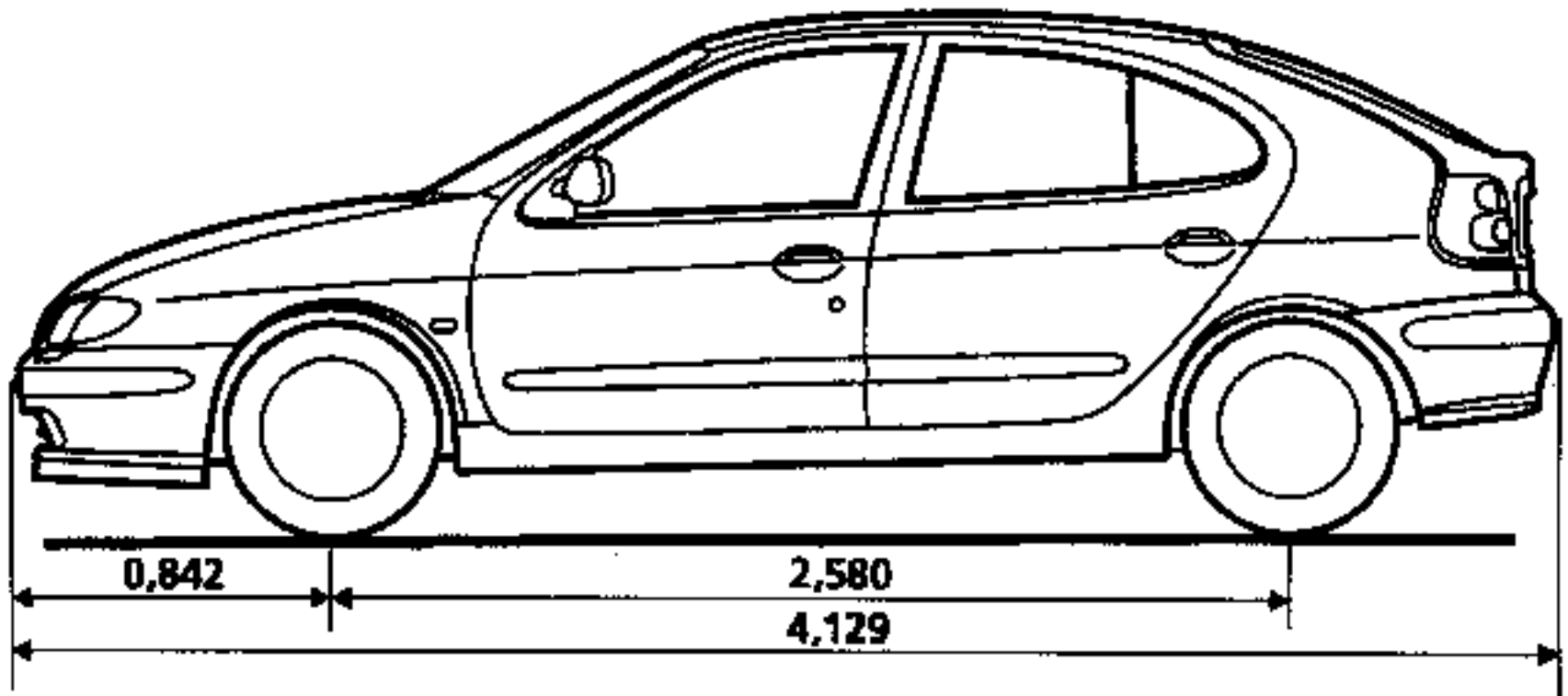

98336R2

* Unladen
** Depending on version
Dimensions in metres

SUB FRAME

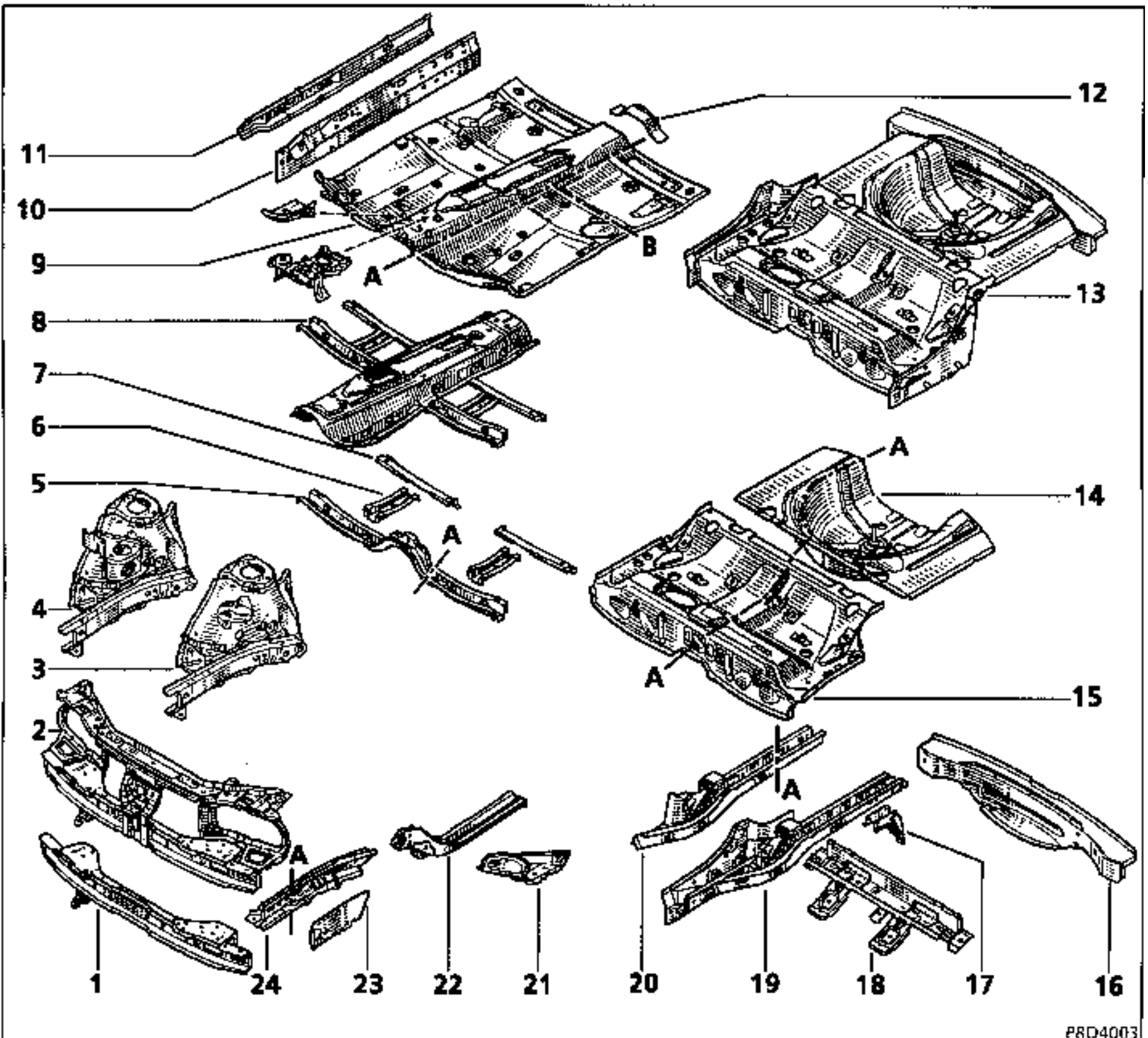

PRD4003

- 1 Front end lower cross member
- 2 Front panel
- 3 Front half unit - without suspended mounting
- 4 Front half unit - with suspended mounting
- 5 Front cross member under front seat
- 6 Front side member extension
- 7 Rear cross member under front seat
- 8 Centre floor reinforcement
- 9 Centre floor
- 10 Inner sill panel
- 11 Inner sill panel stiffener
- 12 Cable sleeve stop

- 13 Rear floor unit
- 14 Rear floor, rear section
- 15 Rear floor, front section
- 16 Rear end cross member
- 17 Securing ring
- 18 Cross member under rear seat
- 19 Rear side member assembly
- 20 Rear side member
- 21 Front side cross member
- 22 Front side member, rear section
- 23 Front side member closure panel
- 24 Front side member

SUB FRAME

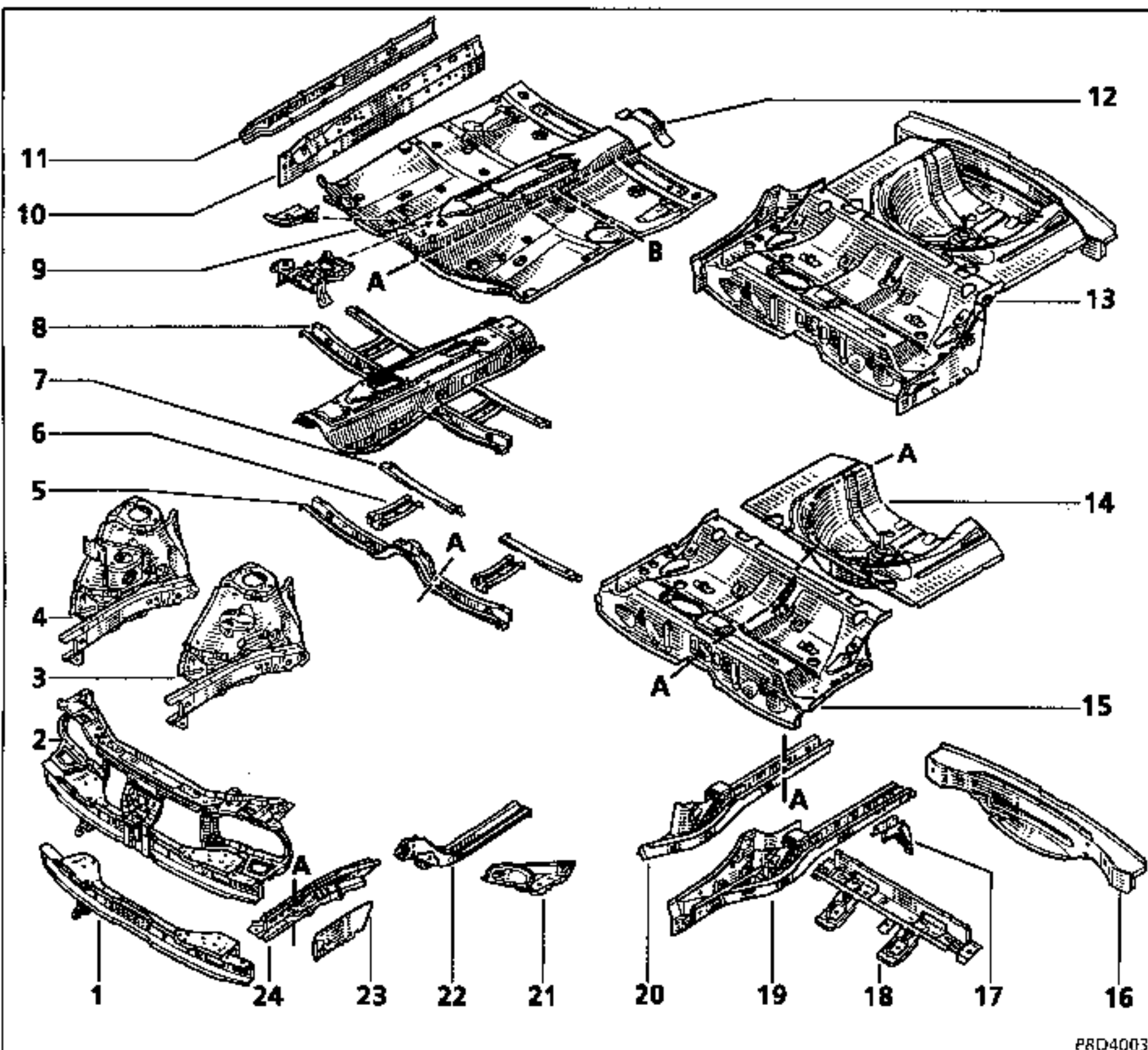

PRD4003

- 1 Front end lower cross member
- 2 Front panel
- 3 Front half unit - without suspended mounting
- 4 Front half unit - with suspended mounting
- 5 Front cross member under front seat
- 6 Front side member extension
- 7 Rear cross member under front seat
- 8 Centre floor reinforcement
- 9 Centre floor
- 10 Inner sill panel
- 11 Inner sill panel stiffener
- 12 Cable sleeve stop

- 13 Rear floor unit
- 14 Rear floor, rear section
- 15 Rear floor, front section
- 16 Rear end cross member
- 17 Securing ring
- 18 Cross member under rear seat
- 19 Rear side member assembly
- 20 Rear side member
- 21 Front side cross member
- 22 Front side member, rear section
- 23 Front side member closure panel
- 24 Front side member