

# Mégane

---

## **1** Engine and peripherals

**10** ENGINE AND PERIPHERALS

**11** TOP AND FRONT OF ENGINE

**12** FUEL MIXTURE

**13** FUEL SUPPLY - PUMPS

**14** ANTIPOLLUTION

**16** STARTING CHARGING

**17** IGNITION - INJECTION

**17** cont INJECTION (Fault finding)

**19** COOLING - EXHAUST - FUEL TANK

---

**BA0A - BA0E - BA0F - BA0G - BA0L - BA0U**

---

77 11 176 211

SEPTEMBER 1995

Edition Anglaise

---

"The repair methods given by the manufacturer in this document are based on the technical specifications current when it was prepared.

The methods may be modified as a result of changes introduced by the manufacturer in the production of the various component units and accessories from which his vehicles are constructed."

All copyrights reserved by the Régie Nationale des Usines Renault.

Copying or translating, in part or in full, of this document or use of the service part reference numbering system is forbidden without the prior written authority of the Régie Nationale des Usines Renault.



Régie Nationale des Usines Renault S.A.1995

---

# EXPLODED VIEW

---

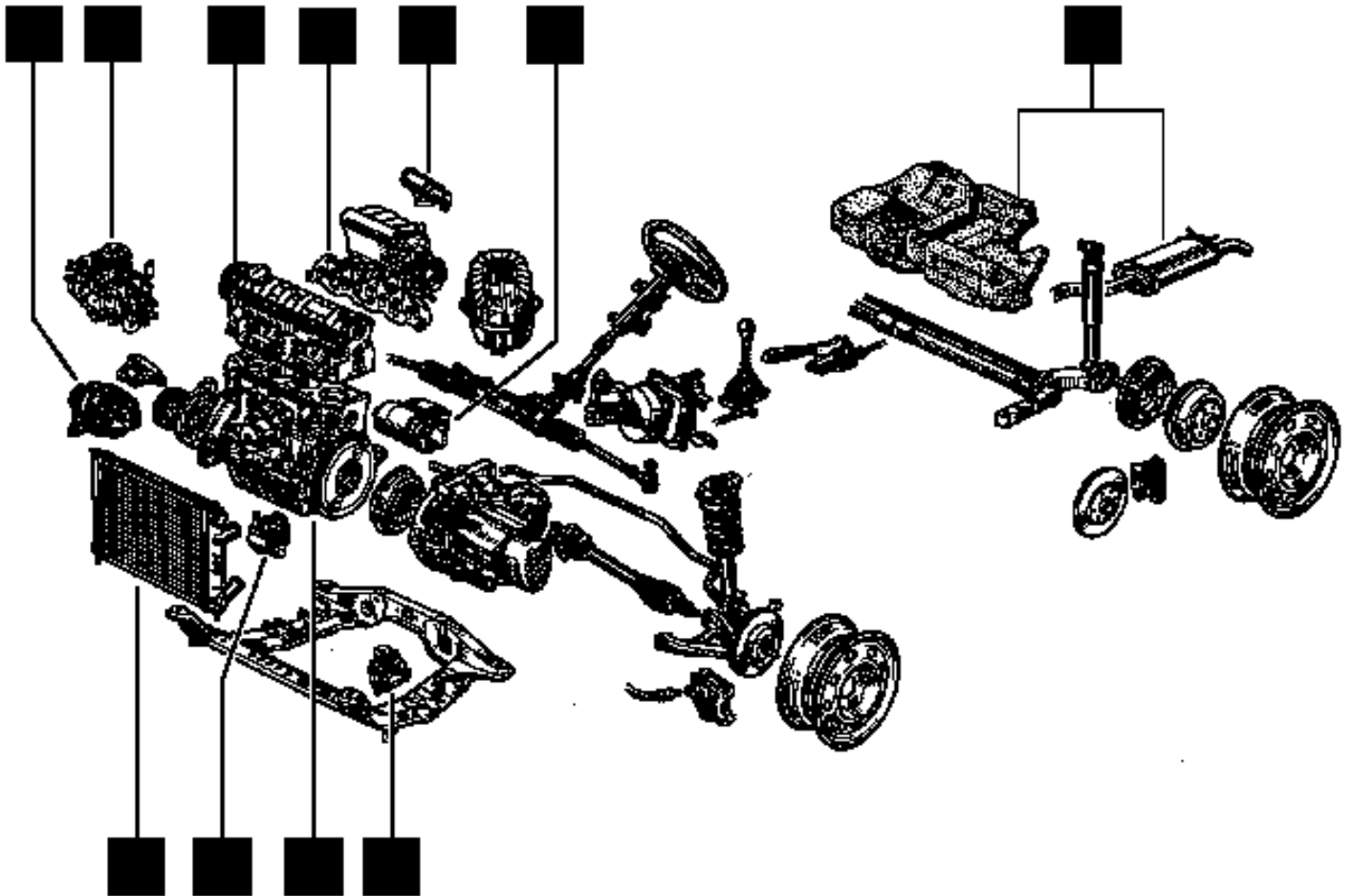

PRJ1005

---

# Engine and peripherals

## Contents

	Page		Page
<b>10 ENGINE AND PERIPHERALS</b>		<b>13 FUEL SUPPLY - PUMPS - PREHEATING</b>	
Consumables	10-1	<b>Fuel supply</b>	
Identification	10-1	Fuel cut-out on impact	13-1
Oil consumption	10-2	Fuel gallery	13-3
Oil pressure	10-3	Injectors	13-8
Engine - Gearbox	10-4	Fuel filter	13-9
Engine and transmission assembly	10-19	Pump flow	13-10
Sump	10-43	Supply pressure	13-11
		<b>Diesel equipment</b>	
		Specifications	13-15
		Description of the pump	13-16
		Tightening torques (in daN.m)	13-17
		Special notes	13-18
		Idle speed settings	13-20
		Microswitches	13-22
		Pump	13-23
		Pump - timing	13-27
		Coded solenoid valve	13-28
		Operating diagram	13-29
		Pre-post-heating unit	13-30
		Injector holder - heater plug	13-36
		Fuel filter	13-37
		Coolant temperature sensor	13-39
		Inlet - exhaust manifolds	13-40
		<b>Pump</b>	
		Brake assistance vacuum pump	13-41
		Mechanical power assisted steering pump	13-42
<b>11 TOP AND FRONT OF ENGINE</b>			
Timing belt	11-1		
Cylinder head gasket	11-12		
<b>12 FUEL MIXTURE</b>			
Specifications	12-1		
Throttle body	12-7		
Inlet manifold	12-15		
Exhaust manifold	12-18		
Manifolds	12-20		

---

## Contents

	Page		Page
<b>14 ANTIPOLLUTION</b>		<b>17 IGNITION - INJECTION</b> (continued)	
Fuel vapour recirculation	14-1	Injection strategy / automatic transmission	17-28
Oil vapour rebreathing	14-9	Injection strategy / air conditioning	17-29
Exhaust gas recirculation (EGR)	14-13	Idle speed correction	17-32
Catalytic converter	14-19	Idle speed adaptive correction	17-33
Catalytic converter - oxygen sensor	14-21	Richness regulation	17-34
Test for the presence of lead	14-22	Adaptive richness correction	17-36
		Operating wiring diagram	17-39
<b>16 STARTING - CHARGING</b>		<b>19 COOLING - EXHAUST- FUEL TANK - ENGINE SUSPENSION</b>	
Alternator	16-1	<b>COOLING</b>	
Starter motor	16-9	Specifications	19-1
		Filling - bleeding	19-2
		Checking	19-3
		Radiator	19-4
		Diagram	19-6
<b>17 IGNITION - INJECTION</b>		<b>Exhaust</b>	
<b>IGNITION</b>		General	19-12
Power module	17-1	Catalytic converter	19-15
Static ignition	17-2	Exhaust pipe assembly	19-16
Spark plugs	17-5	<b>Fuel tank</b>	
<b>Injection</b>		Fuel tank	19-19
General	17-6	Filler neck	19-23
Location of components	17-12	Gauge	19-25
Special notes on semi-sequential injection	17-17	Pump and sender unit	19-26
Special notes on sequential injection	17-19	<b>Engine suspension</b>	
Injection fault warning light	17-24	Suspended engine mountings	19-29
Engine immobiliser function	17-25	Engine mounting pads	19-32
Computer configuration as a function of the gearbox type	17-26		

# ENGINE AND PERIPHERALS

## Consumables

10

Type	Quantity	Components
<b>RHODORSEAL 5661</b> e.g.- CAF 4/60 THIXO	Coat	Driveshaft roll pin holes
<b>Loctite FRENBLOC</b> Brake and sealing resin	Coat	Brake caliper mounting bolts
<b>Loctite FRENETANCH</b> Brake and sealing resin	Coat	Crankshaft pulley mounting bolts
<b>Paste for exhaust pipe</b>	Coat	Exhaust sealing

## Identification

Vehicle type	Engine	Manual gearbox	Capacity (cm <sup>3</sup> )	Bore (mm)	Stroke (mm)	Ratio
BA0E	E7J 764	JB1	1 390	75.8	77	9.5/1
BA0G	F3R 750	JB3	1 998	82.7	93	9.8/1
BA0F	K7M 803	AD4	1 598	79.5	80,5	9.7/1
BA0F BA0L	K7M 702 K7M 720	JB1	1 598	79.5	80,5	9.7/1 9.5/1
BA0A BA0U	F8Q 620	JB1	1 870	80	93	21.5/1

Refer to the correct engine Workshop Repair Manual for the type of engine to repaired:

Engine Document	E7J	F3R	K7M
E engine	X		
F engine (E)		X	
K engine (E) underway			X

### TESTING METHOD

Oil consumption of **1 litre for 1 000 km (620 miles)** is acceptable.

Check there is no external oil leak from the engine.

For accurate testing, certain conditions must be observed when draining the engine oil :

- the engine should be warm,
- the dipstick and filling plug should be removed.

Drain the engine and leave the oil running out for **15 minutes** minimum.

Refit the drain plug and "seal" it (spot of paint covering the plug and the sump) in order to check at a later date that it has not been removed.

Use a measuring cylinder to check the amount of oil required to fill the engine:

Engines:

E7J	2.75 litres
K7M	3 litres
F3R	5.5 litres
F8Q	5 litres

Refit the filling plug and seal it.

Ask the driver to return the vehicle after **1 000 km (620 miles)** during which time the oil level should be monitored regularly with the dipstick.

When the vehicle is returned, check the drain and filling plugs have not been tampered with.

Under the same conditions:

- engine warm,
- dipstick and filling plug removed.

Drain the oil and use a measuring cylinder to check the amount of oil collected.

Calculate the oil consumption in litres per **1 000 km (620 miles)** if the mileage is different.

# ENGINE AND PERIPHERALS

## Oil pressure

# 10

SPECIAL TOOLING	
Mot. 836 -05	Oil pressure testing kit
SPECIAL EQUIPMENT	
Long 22 mm socket	

### CHECKING

The oil pressure must be checked when the engine is warm (approximately 80°C).

Composition of the kit Mot. 836-05.

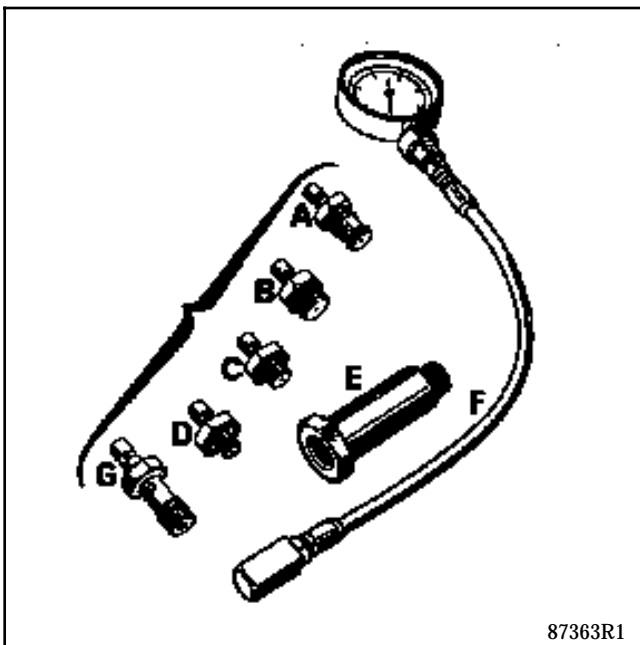

### USE

F engine	E and K engine
B + F	C + E + F

### ENGINE CHECK

#### E and K engines

Idle	<b>1 bar</b>
3 000 rpm.	<b>3 bar</b>

#### F engine

1 000 rpm.	<b>1.2 bar</b>
3 000 rpm.	<b>3.5 bar.</b>

SPECIAL TOOLING	
B.Vi. 31-01	Set of punches
Mot. 1202	Hose clip pliers
T.Av. 476	Ball joint extractor
SPECIAL EQUIPMENT	
Load positioning tool (example : NAUDER 1805)	

TIGHTENING TORQUES (in daN.m)		
Brake caliper bolts	3.5	
Shock absorber base bolt	17	
Track rod end nut	3.5	
Driveshaft gaiter bolt	2.5	
Wheel bolts	9	
Engine tie-bar bolt :		
- on the gearbox	6.5	
- on the sub-frame	7.5	
Right hand engine mounting nut	4.5	
Left hand gearbox mounting nut	4.5	

### REMOVAL

Put the vehicle on a 2 post lift.

Drain the gearbox.

Disconnect the battery.

Remove:

- the bonnet,
- the front wheels.

### *Left hand side of the vehicle*

Remove:

- track rod end using tool **T.Av. 476**,
- the three bolts of the driveshaft gaiter,
- the two bolts from the shock absorber base,
- the two bolts from the brake caliper then secure it to the shock absorber spring,
- the bolt from the lower ball joint,
- the complete hub assembly and the driveshaft.

### *Right hand side of the vehicle*

Remove the pins from the right hand driveshaft using tool **B.Vi. 31-01**.

Remove:

- the track rod end using tool **T.Av. 476**,
- the upper shock absorber bolt and slacken the nut on the lower bolt without removing it.

Remove the driveshaft from the gearbox.



Remove:

- the catalytic converter,
- the gearbox selector rod,
- the nuts (1) from the engine and gearbox mountings,
- the nuts (2) engine tie-bar mounting,

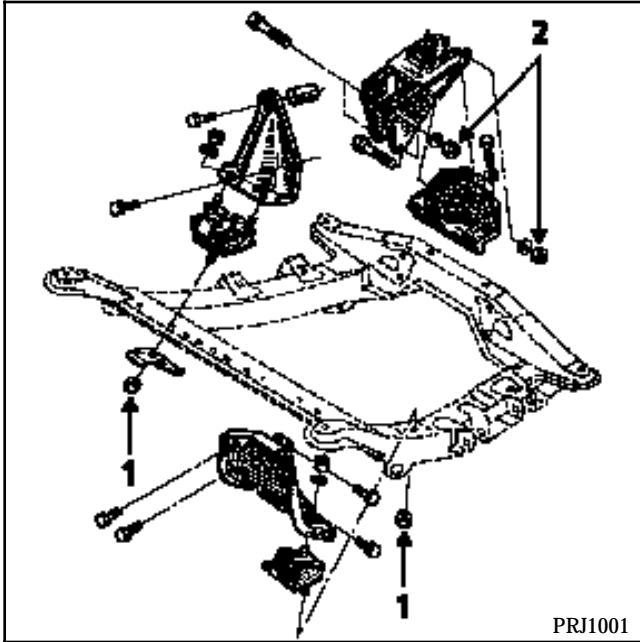

- the power assisted steering pipe mountings from the gearbox,

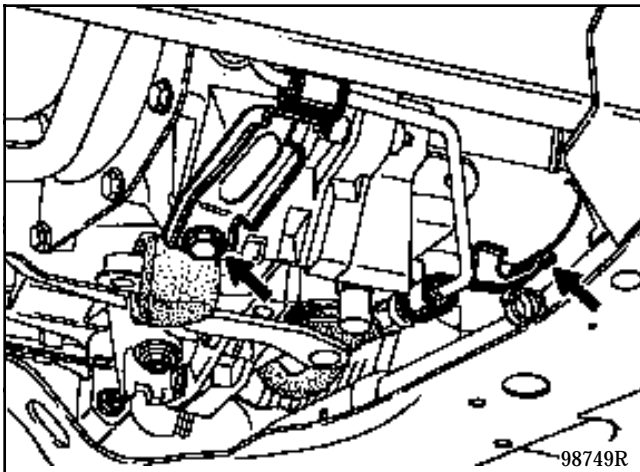

- the speedometer.

Disconnect the reversing light.

Remove:

- the power assisted steering pump,

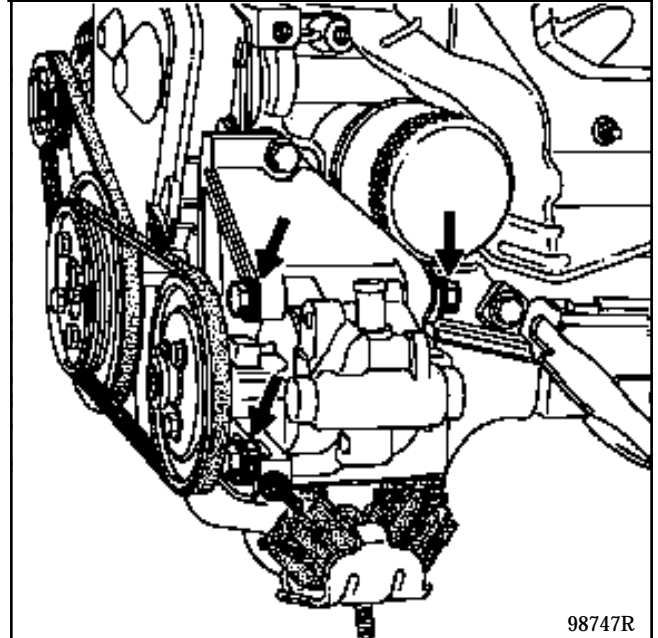

- the power assisted steering reservoir,
- the air filter,
- the accelerator cable from the throttle body,
- the clutch cable from the gearbox,
- hoses (4), (5), (6) and (7),

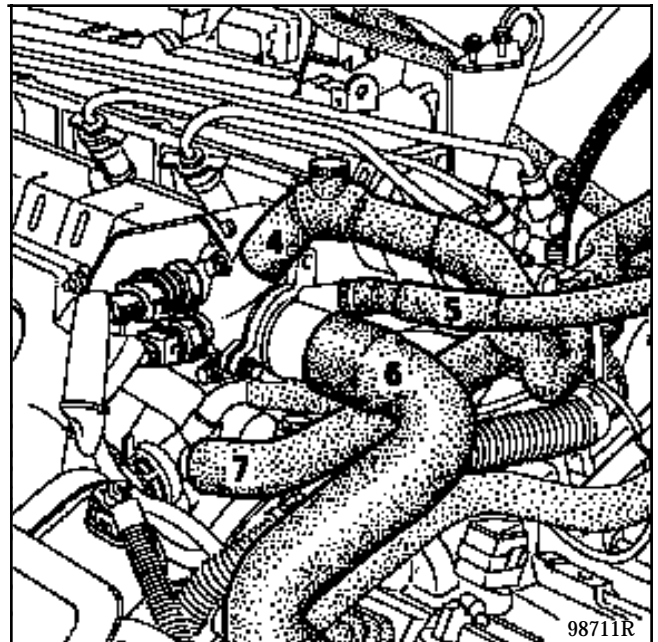

- the relay plate and the engine connection unit connector.

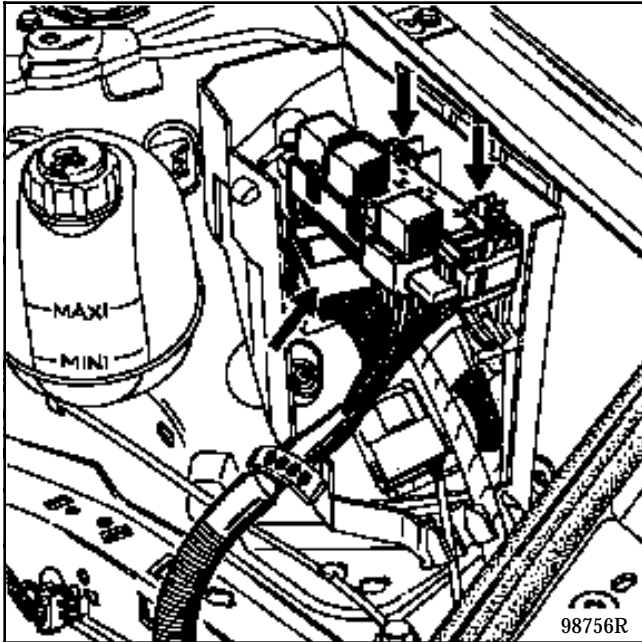

Remove the pipe from the brake servo.

Disconnect the thermistor and the fan unit feed.

Remove:

- the absolute pressure sensor,
- the ignition module,
- the fuel pipes,

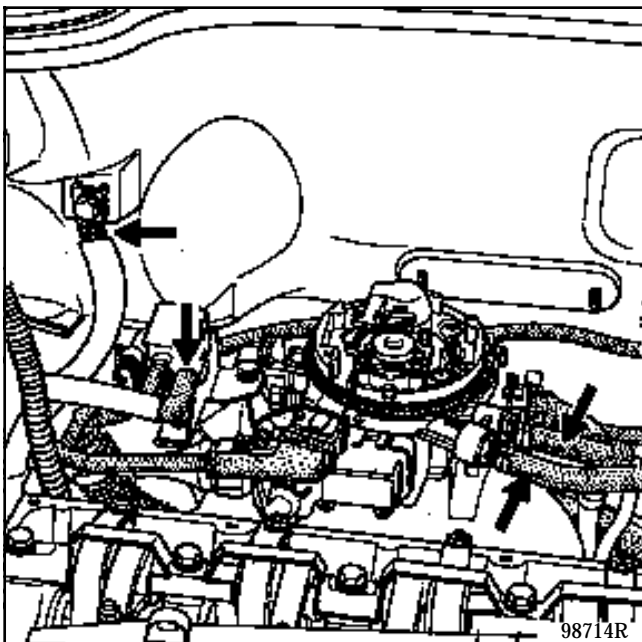

- the earth strap,
- the pipe from the canister solenoid valve,
- the injection computer and secure it to the engine,
- the starter feed wire from the battery.

Disconnect the injection feed wire located in the scuttle panel.

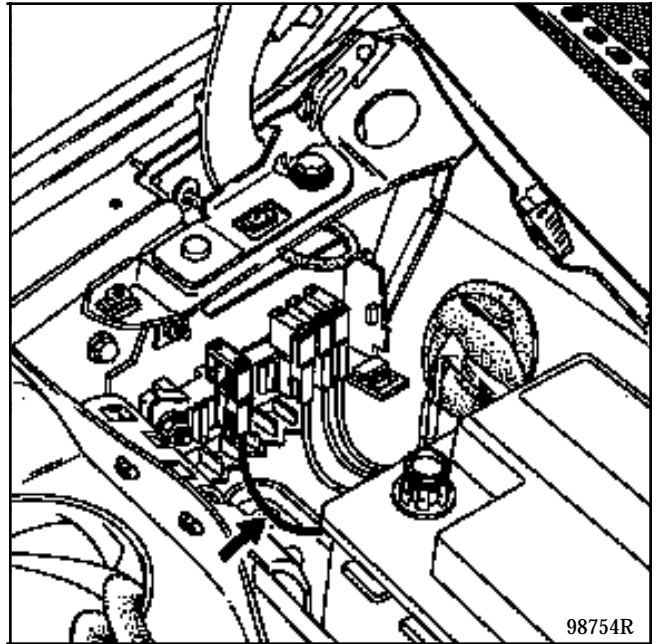

Position the load positioning tool.

Lift the engine to remove the three bolts and the engine tie-bar mounting.

Remove the engine.

### REFITTING

Refitting is the reverse of removal.

Fill the gearbox and the cooling circuit and bleed the circuit (see section 19).

**NOTE:** ensure the heat shields are correctly positioned.

SPECIAL TOOLING	
Mot. 1202	Hose clip pliers
T.Av. 476	Ball joint extractor
B.Vi. 31-01	Set of punches
SPECIAL EQUIPMENT	
Load positioning tool (example : NAUDER 1805)	

TIGHTENING TORQUES (in daN.m)		
Brake caliper mounting bolt	3.5	
Shock absorber base bolt	17	
Track rod end nut	3.5	
Driveshaft gaiter mounting bolt	2.5	
Wheel bolts	9	
Engine tie-bar bolt :		
- on the gearbox	6.5	
- on the sub-frame	7.5	
Right hand engine mounting nut	4.5	
Left hand gearbox mounting nut	4.5	

### REMOVAL

Put the vehicle on a 2 post lift.

Drain the gearbox.

Disconnect the battery.

Remove:

- the bonnet,
- the front wheels.

### *Left hand side of the vehicle*

Remove:

- track rod end using tool **T.Av. 476**,
- the three bolts of the driveshaft gaiter,
- the two bolts from the shock absorber base,
- the two bolts from the brake caliper then secure it to the shock absorber spring,
- the bolt from the lower ball joint,
- the complete hub assembly and the driveshaft.

### *Right hand side of the vehicle*

Remove the pins from the right hand driveshaft using tool **B.Vi. 31-01**.

Remove:

- the track rod end using tool **T.Av. 476**,
- the upper shock absorber bolt and slacken the nut on the lower bolt without removing it.

Remove the driveshaft from the gearbox.

## Remove:

- the heat shield from the exhaust manifold
- the catalytic converter,
- the gearbox selector rod,
- the nuts (1) from the engine and gearbox mountings,
- the nuts (2) from the engine tie-bar mounting,

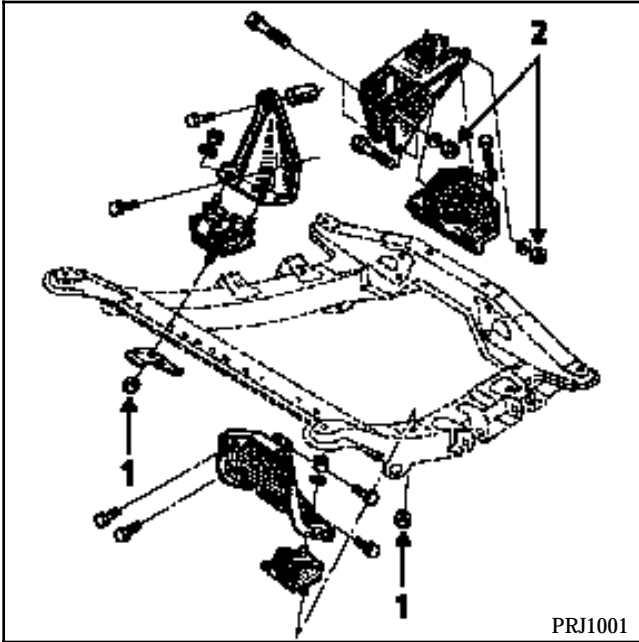

- the power assisted steering pipe mountings from the gearbox,

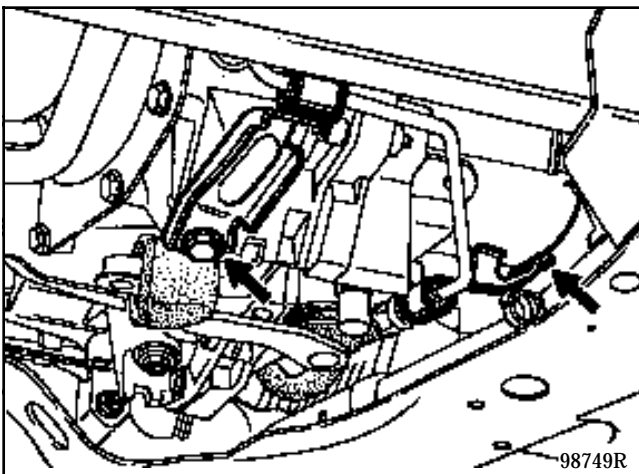

- the speedometer.

Disconnect the reversing light.

## Remove:

- the acoustic tie-rod between the two shock absorber turrets,
- the air filter,
- the accelerator cable from the throttle body,
- the clutch cable from the gearbox,
- the hoses (4), (5), (6), (7) and (8),

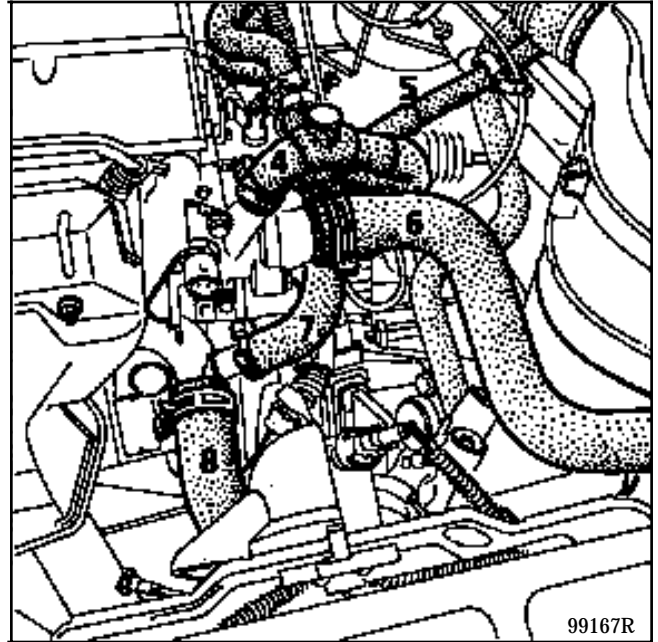

- the expansion bottle and secure it to the wheelarch,
- the fuel supply and return pipes,
- the brake servo pipe,
- the absolute pressure sensor,
- the earth strap.

## Disconnect:

- the power assisted steering and air conditioning pressostats,
- the compressor supply and the fan unit supply,
- the temperature switch sensor.

Remove:

- the relay plate and the engine connection unit connector,

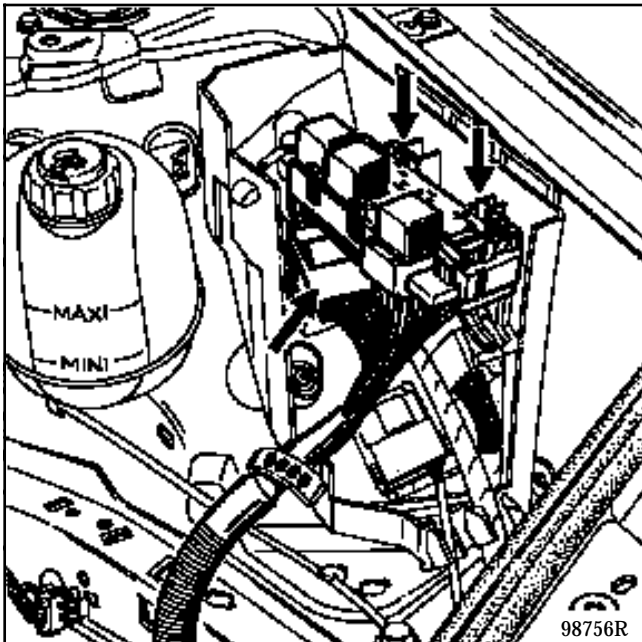

- the pipe from the canister solenoid valve,
- the injection computer and secure it to the engine,
- the starter motor feed wire from the battery.

Disconnect the injection feed wire located in the scuttle panel.

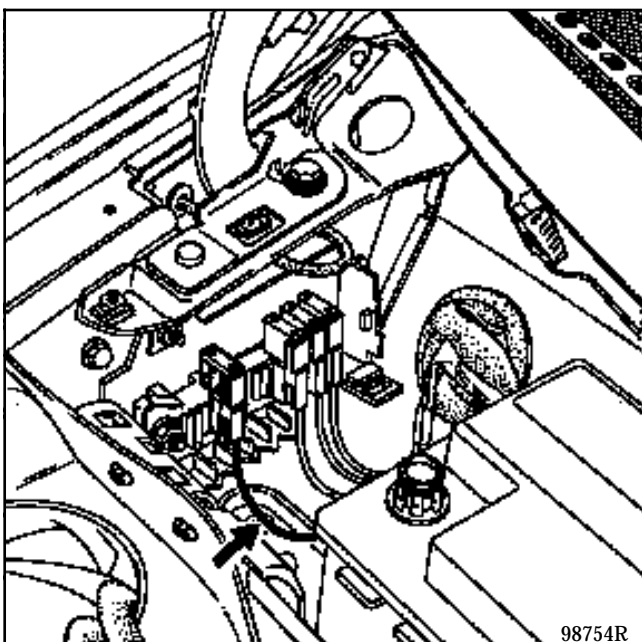

Remove:

- the accessories belt,
- the power assisted steering pump pulley.

Move the power assisted steering pump and the the air conditioning compressor away (without opening the circuits).

Secure the low pressure pipe for the compressor to the air filter mounting.

Position the load positioning tool.

Lift the engine to remove the three bolts, the engine tie-bar mounting and the gearbox mounting.

Remove the engine.

### REFITTING

Refitting is the reverse of removal.

Fill the gearbox and the cooling circuit and bleed the circuit (see section 19).



Fit the brake caliper bolts with **Loctite FRENBLOC** and tighten to the correct torque.

Press the brake pedal several times to bring the pistons back into contact with the pads.

**NOTE:** ensure the heat shields are correctly positioned.

SPECIAL TOOLING	
B. Vi. 31 -01	Roll pin punches
Mot. 1202	Hose clip pliers
Mot. 1273	Tool for checking belt tension
Mot. 1289 -03	Fork for centring suspended engine mounting limiter
T.Av. 476	Ball joint extractor
SPECIAL EQUIPMENT	
Load positioning tool (example: NAUDER 1805)	

TIGHTENING TORQUES (in daN.m)	
Brake caliper mounting bolts	3.5
Shock absorber base bolts	17
Driveshaft gaiter mounting bolts	2.5
Wheel bolts	9
Engine tie-bar bolt	4.5 to 6.5
Suspended engine mounting bolt on gearbox	4
Nut for suspended engine mounting pad on front left hand side member	7.5
Front right hand suspended engine mounting cover bolt on engine	4
Front right hand suspended engine mounting movement limiter bolt	6
Nut for engine mounting pad on front right hand suspended engine mounting cover	4.5

### REMOVAL

Put the vehicle on a two post lift.

Disconnect the battery.

Drain the gearbox.

Remove:

- the front wheels,
- the front right hand and left hand mudguards.

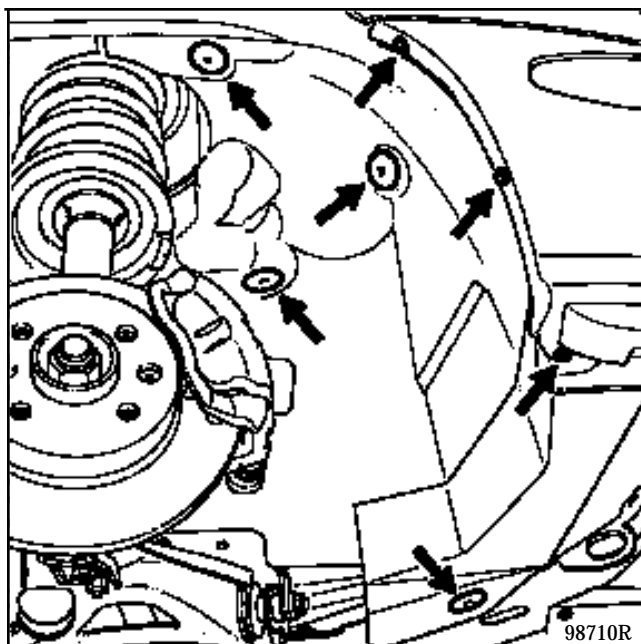

### Left hand side of the vehicle

Remove:

- track rod end using tool **T.Av. 476**,
- the three bolts for the driveshaft gaiter,
- the two bolts from the shock absorber base,
- the two bolts from the brake caliper then secure it to the shock absorber spring,
- the bolt from the lower ball joint,
- the complete hub assembly and the driveshaft.

### Right hand side of the vehicle

Remove the pins from the right hand driveshaft using tool **B.Vi. 31-01**.

Remove:

- the track rod end using tool **T.Av. 476**,
- the upper shock absorber bolt and slacken the nut on the lower bolt without removing it.

Remove the driveshaft from the gearbox.

Remove:

- the exhaust downpipe,
- the gearbox selector rod,
- the power assisted steering pipe mountings on the gearbox.

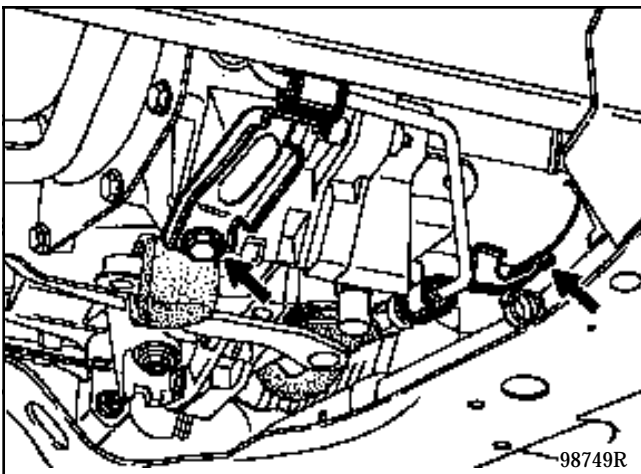

Unclip the reversing light wiring loom from the sub-frame.

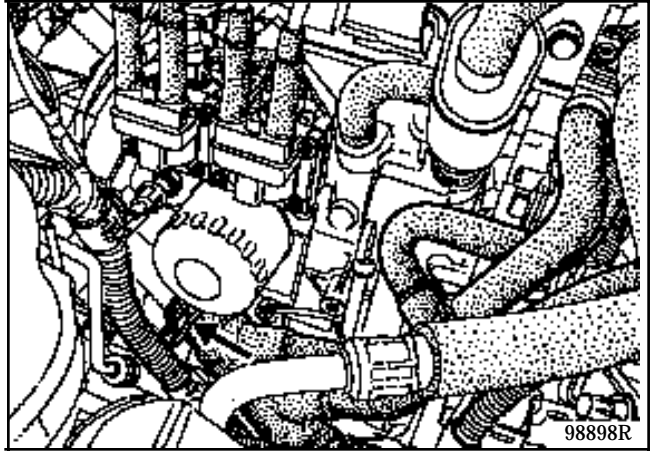

Drain the cooling circuit through the lower radiator hose at the water pump end.

Remove:

- the air filter as well as the sleeve and its mounting,
- the tie-bar between the shock absorber turrets,
- the accelerator and clutch cables,
- the brake servo pipe,
- the two heating hoses,
- the lower expansion bottle hose,
- hoses (1), (2) and (3),

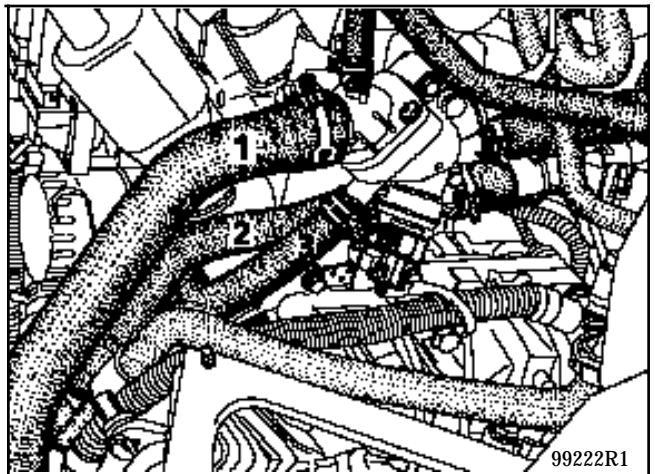

- the relay plate and the engine connection unit connector,

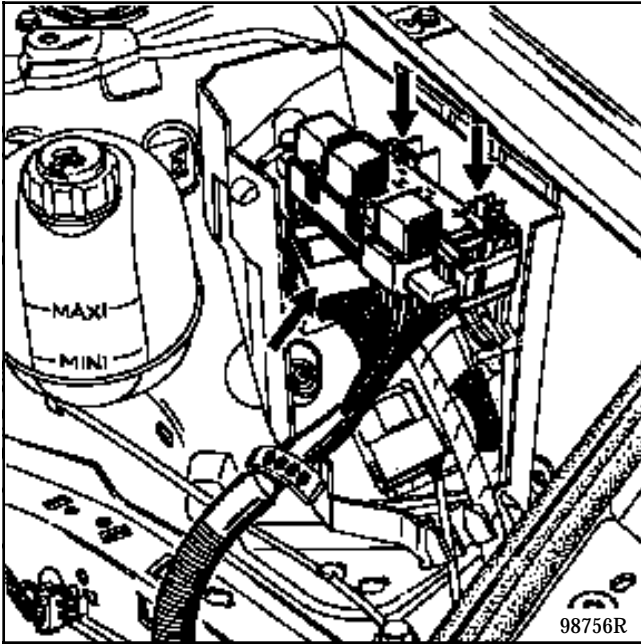

- the earth strap,
- the suspended engine mounting cover cap.

#### Disconnect:

- the injection computer and unclip it from the computer mounting,
- the injection feed wire located in the scuttle panel,
- the starter motor feed.

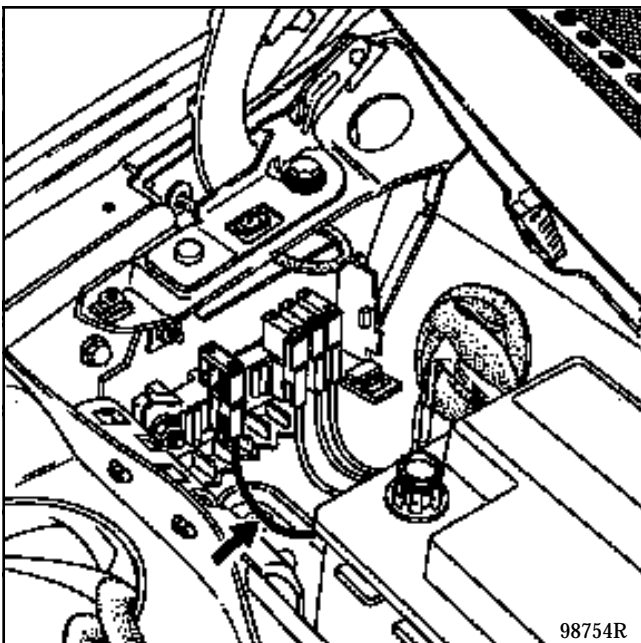

Remove the fuel supply and return pipes.

Remove the absolute pressure sensor.

#### Disconnect:

- the air conditioning and power assisted steering pressostats,
- the compressor and fan unit supply,
- the temperature switch sensor and the oxygen sensor,
- the canister bleed pipe.

#### Remove:

- the expansion bottle,
- the injection computer mounting,
- the accessories belt (see section 11),
- the power assisted steering pulley.

Remove the three bolts (1) from the power assisted steering pump and the four bolts (2) from the air conditioning compressor.

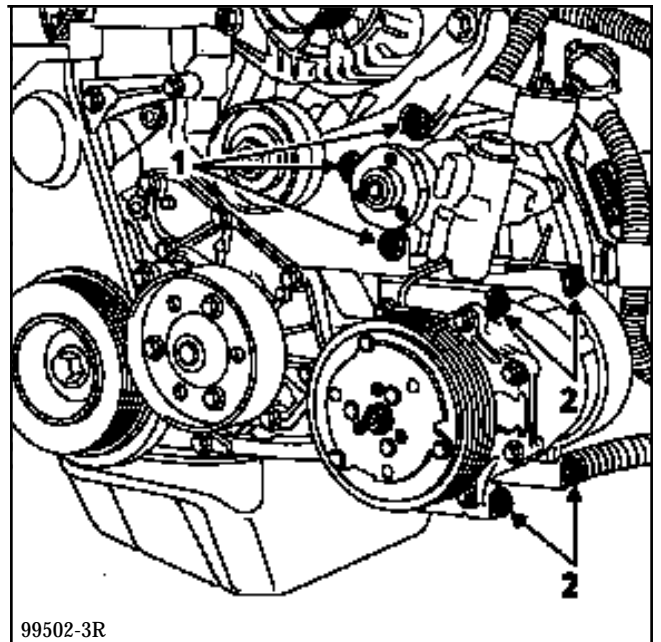



Move the power assisted steering pump and the air conditioning compressor away (without opening the circuits).

Remove the air conditioning low pressure pipe clip on the suspended gearbox mounting.

Remove the bonnet.

Remove the engine tie-bar.

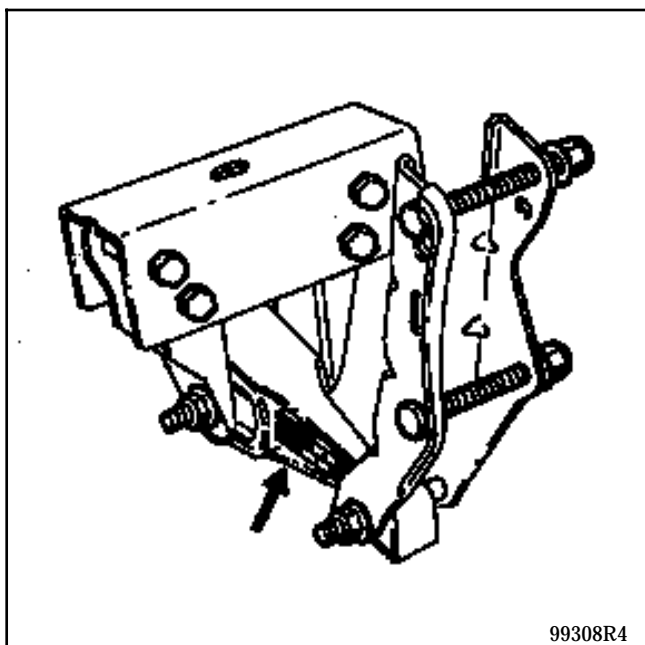

Position the load positioning tool.

Lift the engine to remove the suspended engine mountings and gearbox.

Remove the engine.

### REFITTING

Refitting is the reverse of removal.

For the accessories belt tension (see section 07).

Fit the suspended engine mounting cover and the movement limiter assembly.

### ADJUSTING THE LONGITUDINAL MOVEMENT LIMITER

Slacken the two limiter bolts (E).

Insert the fork for centring the limiter **Mot. 1289-03** into the openings in the suspended engine mounting cover.

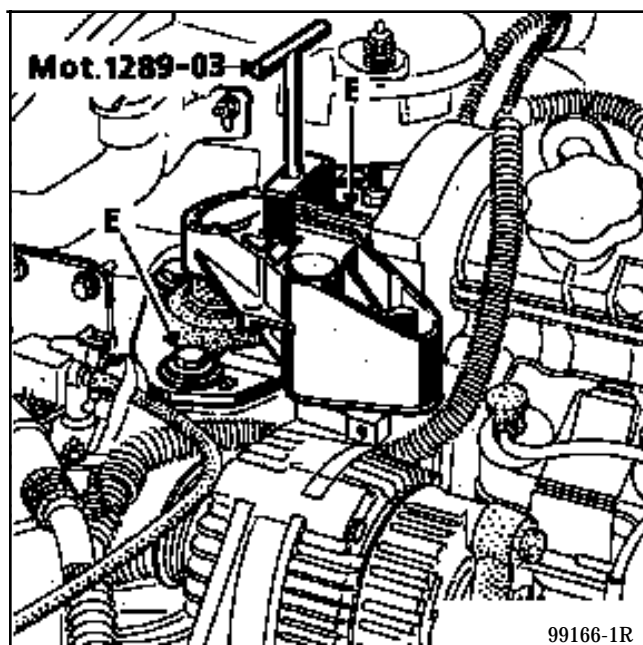

Tighten the two limiter bolts (E) to a torque of 6 daN.m.

Fill the gearbox and cooling circuit and bleed the circuit (see section 19).



Fit the brake caliper bolts with **Loctite FRENBLOC** and tighten to the correct torque.

Press the brake pedal several times to bring the pistons back into contact with the pads.

**NOTE:** ensure the heat shields are correctly positioned.

SPECIAL TOOLING	
B. Vi. 31 -01	Roll pin punches
Mot. 1202	Hose clip pliers
Mot. 1311-06	Tool for removing fuel pipes
T.Av. 476	Ball joint extractor
SPECIAL EQUIPMENT	
Load positioning tool (example : NAUDER 1805)	

TIGHTENING TORQUES (in daN.m)	
Brake caliper mounting bolt	3.5
Shock absorber base bolt	17
Track rod end	3.5
Lower ball joint nut	6.5
Driveshaft gaiter mounting bolt	2.5
Wheel bolts	9
Engine tie-bar bolt	6
Suspended engine mounting bolt on gearbox	5.5
Bolt for suspended engine mounting pad on front left hand side member	2.5
Front right hand suspended engine mounting cover bolt on engine	4
Front right hand suspended engine mounting movement limiter bolt	6

### REMOVAL

Put the vehicle on a two post lift.

Disconnect the battery.

Remove:

- the bonnet,
- the engine undertray.

Drain:

- the gearbox.
- the cooling circuit through the lower radiator hose (radiator end).

Remove:

- the front wheels,
- the front right hand and left hand mudguards.

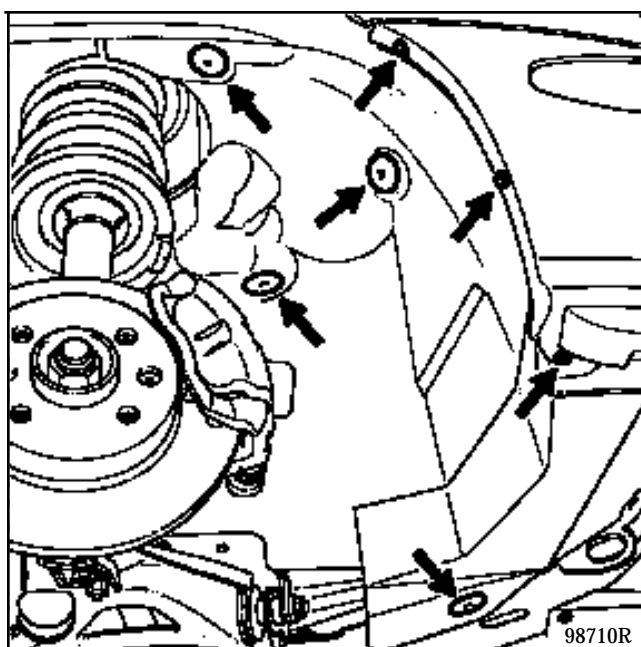

98710R

- the air inlet sleeve, the air filter and its mounting,
- the cooling assembly (see section 19 "Radiator"),
- the alternator belt (see section 16 "Alternator").

Disconnect the compressor feed wire (if fitted).

Remove:

- the compressor mounting bolts (if fitted) and secure it to the front cross member,
- the power assisted steering pump pulley,
- the oil filter,
- the power assisted steering pump mounting bolts as well as the power assisted steering pipe bracket bolt.

Move the pump away and secure it to the sub-frame.

Disconnect:

- the heating hoses on the thermostat mounting,

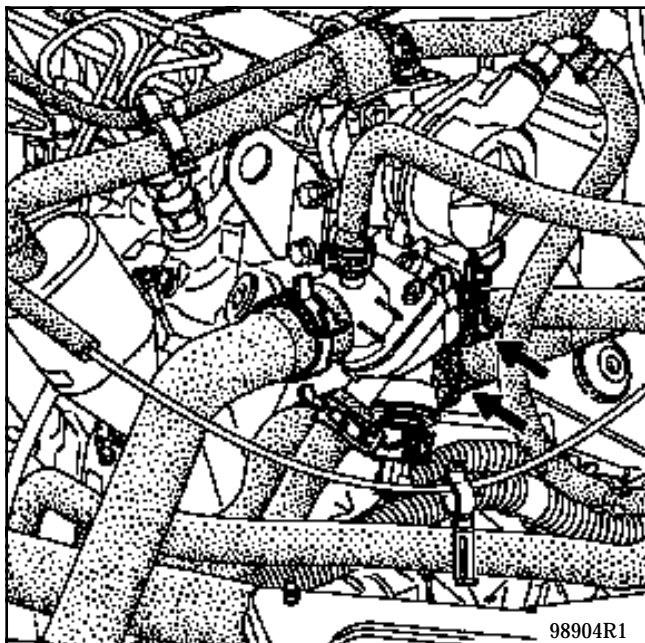

- the brake servo pipe,
- the pipes and connectors on the fast idle and EGR solenoid valves,

- the preheating unit (secure it to the engine),
- the accelerator and clutch cables,
- the altimetric sensor corrector,
- the relay plate and the engine connection unit electrical connector,

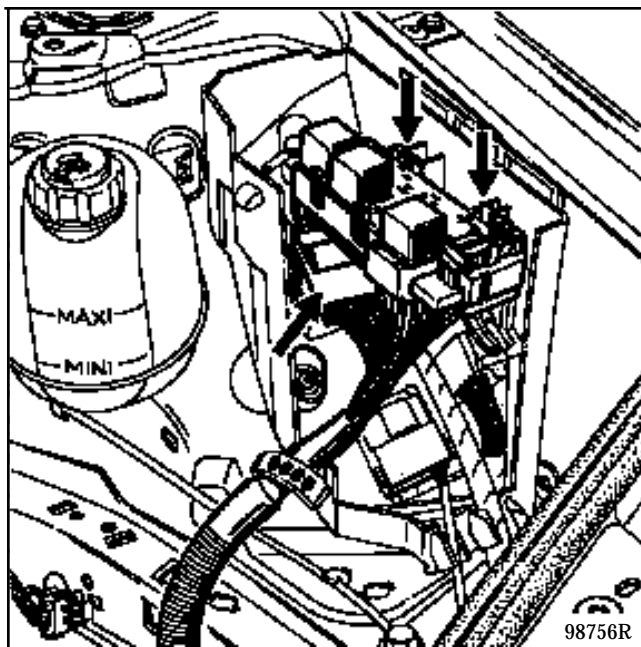

- the fuel supply pipe on the diesel filter using tool Mot. 1311-06,

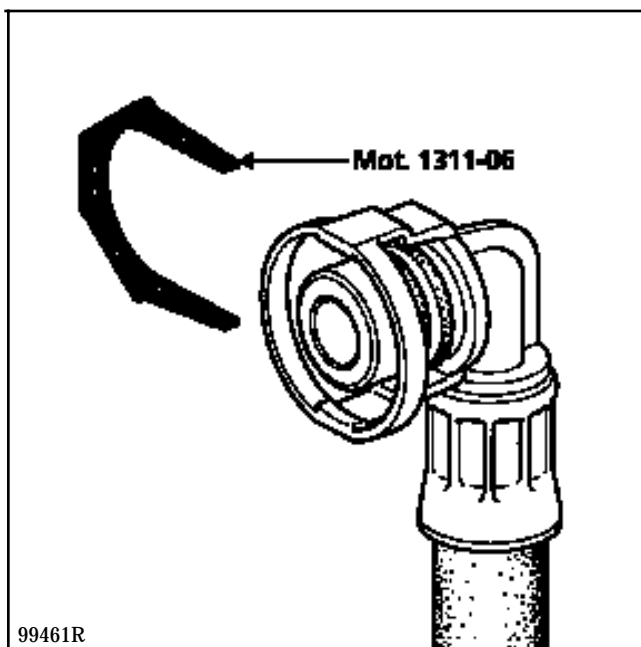

- the connector on the diesel filter.

Remove:

- the diesel return union on the injection pump,
- the earth strap,
- the tie-rod between the shock absorber turrets,
- the battery mounting bracket.

Disconnect the feed wire from the preheating unit in the scuttle panel as well as the starter motor feed.

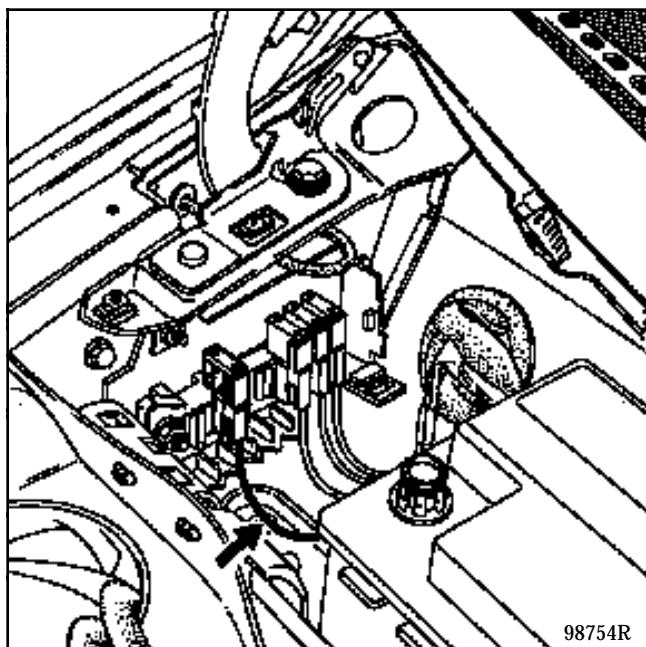

#### *Left hand side of the vehicle*

Remove:

- track rod end using tool T.Av. 476,
- the three bolts for the driveshaft gaiter,
- the two bolts from the shock absorber base,
- the two bolts from the brake caliper then secure it to the shock absorber spring,
- the bolt from the lower ball joint,
- the complete hub assembly and the driveshaft.

#### *Right hand side of the vehicle*

Remove:

- the pins from the driveshaft using tool B.Vi. 31-01,
- the upper bolt from the shock absorber base and slacken the lower bolt.

Tilt the stub axle carrier and release the driveshaft.

Remove:

- the exhaust pipe,
- the gear control on the gearbox side,
- the power assisted steering pipe mountings from the gearbox,

