

Peterbilt Model 320 Operators Manual Supplementalmanuals

Full download: <http://manualplace.com/download/peterbilt-model-320-operators-manual-supplementalmanuals/>

OPERATOR'S

MANUAL

Model
320



CLASS PAYS

This is the cut pages sample. Download all 212 page(s) at: ManualPlace.com

Quick Table of Contents

PART 1: INTRODUCTION.....	1
PART 2: CAB AND FRAME ACCESS.....	6
PART 3: GETTING TO YOUR ENGINE.....	10
PART 4: CONTROLS AND DISPLAYS.....	15
PART 5: SEAT AND RESTRAINT SYSTEMS.....	57
PART 6: DRIVER'S CHECKLIST.....	69
PART 7: STARTING & OPERATING THE VEHICLE.....	73
PART 8: MAINTENANCE AND SERVICE.....	110
PART 9: VEHICLE IDENTIFICATION NUMBERS.....	196
PART 10: CONSUMER INFORMATION.....	199
PART 11: SUBJECT INDEX.....	202
Other Publications.....	206

California Proposition 65 Warning

- Diesel engine exhaust and some of its constituents are known to the State of California to cause cancer, birth defects, and other reproductive harm.
- Other chemicals in this vehicle are also known to the State of California to cause cancer, birth defects or other reproductive harm.
- Battery posts, terminals, and related accessories contain lead and lead compounds, chemicals known to the State of California to cause cancer and reproductive harm. Wash hands after handling.

PART 1: INTRODUCTION

This manual contains useful information for the safe and efficient operation of your Model 320. It also provides information on maintaining your vehicle in the best condition, with an outline for performing safety checks and basic preventive maintenance inspections.

We have tried to present the information you'll need to learn about your vehicle's functions, controls, and operation - and to present it as clearly as possible. We hope you'll find this manual easy to use.

There will be times when you need to take this manual out of your Peterbilt. When you do, please be sure to return it to the cab when you are finished using it. That way it will be there when you need it the next time or when you pass the vehicle on to the next user.

Your Model 320 may not have all the features or options mentioned in this manual. Therefore, you should pay careful attention to the instructions that pertain to just your vehicle. In addition, if your vehicle is equipped with special equipment or options not discussed in this manual, consult your dealer or the manufacturer of the equipment.

All information contained in this manual is based on the latest production information available at the time of publication. Peterbilt Motors Company reserves the right to make changes at any time without notice.

How To Find What You Want

There are several tools built into this manual to help you find what you need quickly and easily.

First is the Quick Table of Contents. Located at the front of the manual, this lists the main subjects covered and gives page numbers where you can find these subjects. Use the Quick Table of Contents to find information on a large subject like "Maintenance."

Cross-referenced Citations also help you get the information you need. If some other part of the manual contains further information on the subject you are reading about, we'll indicate that in a cross-reference like this: (See "PART 6: DRIVER'S CHECKLIST"). You won't have to go searching for more information.

Finally you'll find a helpful Subject Index. It's in the back of the manual and alphabetically lists the subjects covered.

So if you want information on brakes, for example, just look under Brake in the Subject Index. You'll find all the pages listed where brakes or braking are discussed.

A Special Word About Repairs

Your Peterbilt dealer's service center is the best place to have your vehicle repaired. You can find Peterbilt dealers all over the country with the equipment and trained personnel to get you back on the road quickly - and keep you there.

Your vehicle is a complex machine. Anyone attempting repairs on it needs good mechanical training and the proper tools. If you are sure you have these requirements, then you can probably perform some repairs yourself. However, all warranty repairs must be performed by an authorized Peterbilt service facility. If you aren't an experienced mechanic, or don't have the right equipment, please leave all repairs to an authorized service facility. They are the ones equipped to do the job safely and correctly.



WARNING! Attempting repair work without sufficient training, service manuals, and the proper tools can be dangerous. You could be injured or you could make your truck unsafe. Do only those tasks you are fully qualified to do.

Maintenance Manuals. If you do decide to do any complex repair work, you'll need the Peterbilt Maintenance manuals. Order them from your authorized dealer. Please provide your Chassis Serial Number when you order, to be sure you get the correct manuals for your vehicle. Allow about four weeks for delivery. There will be a charge for these manuals.

Final Chassis Bill of Material. A complete, nonillustrated computer printout listing of the parts used to custom-build your Peterbilt vehicle is available through the Peterbilt dealer from whom you purchased your vehicle.



WARNING! Modifying your vehicle can make it unsafe. Some modifications can affect your truck's electrical system, stability, or other important functions. Before modifying your vehicle, check with your dealer to make sure it can be done safely.

Additional Sources of Information

Operator's manuals are also supplied by the manufacturers of components such as the engine, seats, transmission, and radio in your Peterbilt. If you are missing any of these manuals, ask your Peterbilt dealer to supply them.

Your new Peterbilt also contains a copy of the Truck Driver's Handbook, published by the American Trucking Association. Refer to it for important information on driving your vehicle. Another place to learn more about trucking is a local truck driving school. Contact one near you to find out what kinds of instruction it offers.

Federal and state agencies also have information you can ask for. The Interstate Commerce Commission can give you information about regulations governing transportation across state lines. And various agencies in state governments are sources for regulations which differ from state to state.

Warnings

We've put a number of warning messages in this manual. They are there for your protection and information. Please read them and follow them. They can help you to avoid injury to yourself and your passengers as well as to prevent costly damage to your vehicle. We've used certain symbols and "signal words" to indicate what kind of message is going to follow. When you see these symbols & words, you know that you need to pay special attention. Please don't ignore any of these signals.



WARNING:

When you see this symbol & word, the message that follows is especially vital. This signals something that can cause serious injury or death. This message will tell you what the hazard is, what can happen if you don't heed the warning, and how to avoid it. For example:



WARNING! Attempting repair work without sufficient training, service manuals, and the proper tools can be dangerous. You could be injured or you could make your vehicle unsafe. Do only those tasks you are fully qualified to do.



CAUTION:

This symbol & word signals something that could damage your vehicle. You might receive an injury, too. For example:



CAUTION: Continuing to operate a vehicle with insufficient oil pressure will cause serious engine damage.

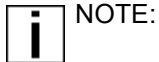

NOTE:

Gives you information we feel you'd like to have. It could have to do with care of your vehicle or with driving more efficiently:



NOTE: A cold compressor can cause refrigerant to liquefy and warp the valve plates or cause a hydraulic lock. Warm the engine before starting the air conditioner.

Please take the time to read these messages when you see them. And remember:

WARNING! Something that could injure you seriously.

CAUTION: Something that could cause injury to you or your vehicle.

NOTE: Useful information.

Vehicle Safety

Make sure your Peterbilt is in top working condition before heading out on the road—it is the responsible driver's

duty to do so. Inspect the vehicle according to "PART 6: DRIVER'S CHECKLIST".



WARNING! *Do not drink and drive. Your reflexes, perceptions, and judgment can be affected by even a small amount of alcohol. You could have a serious—or even fatal accident—if you drive after drinking. Please do not drink and drive or ride with a driver who has been drinking.*



WARNING! *The use of alcohol, drugs, and certain medications will seriously impair perception, reactions, and driving ability. These circumstances can substantially increase the risk of an accident and personal injury.*

Please remember, this manual is not a training manual. It cannot tell you everything you need to know about driving your Peterbilt vehicle. For that you need a good training program or truck driving school. If you have not been trained, get the proper training before you drive. Only qualified drivers should drive this vehicle.

Every new Peterbilt vehicle is designed to conform to all Federal Motor Vehicle Safety Standards applicable at the

time of manufacture. However, even with these safety features, continued safe and reliable operation depends greatly upon regular vehicle maintenance. The vehicle

must be operated within the range of its mechanical capabilities and the limits of its load ratings. See the axle and tire load rating information located on the driver's door jamb.

PART 2: CAB AND FRAME ACCESS

Be careful whenever you get into or out of your vehicle's cab. Always maintain at least three points of contact with your hands on the grab handles and your feet on the steps.



WARNING! Jumping out of the cab or getting into the cab without proper caution is dangerous. You could slip and fall, possibly suffering a serious injury. Keep steps clean. Clean any fuel, oil, or grease off of the steps before entering the cab. Use the steps and grab handles provided, and always keep at least three points of contact between your hands and feet and the truck. Look where you are going.

The following pictures show the best way to enter and exit a Model 320.

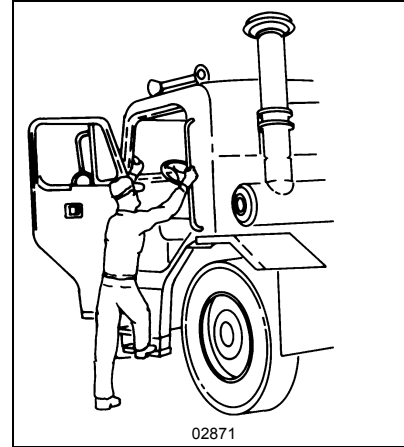

Three points of contact as you begin or finish

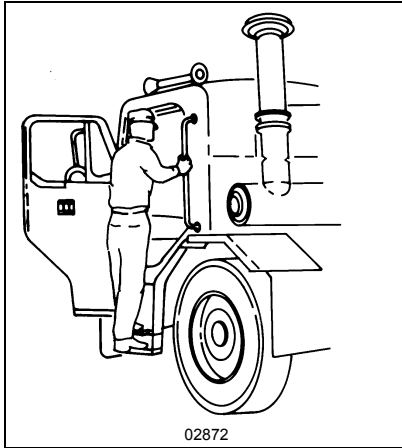

Three points of contact as you climb up or down

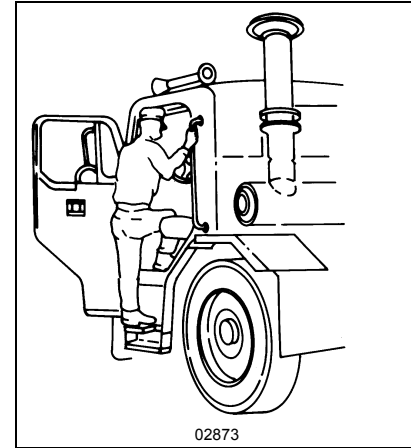

Three points of contact as you step in or out

Door Lock and Keys

Doors can be locked from the inside by using the lock button. Close the door then push the button down to lock. Doors automatically unlock when you open them from the inside, and can be locked from the outside with a key only.



WARNING! To lessen the chance and/or severity of personal injury in case of an accident, always lock the doors while driving. Along with using the lap/shoulder belts properly, locking the doors helps prevent occupants from being thrown from the vehicle.

To lock or unlock the doors from outside the cab, insert the key in the lock. Turn the key toward the rear to lock; forward to unlock.

Climbing Onto the Deck Plate



WARNING!

- **You can be hurt if you aren't careful climbing onto and off the deck plate. You can slip and fall, especially if the surfaces are wet or**

icy, or if you step in oil, fuel, or grease. Keep steps clean. Always maintain at least three points of contact between your hands and feet and the steps and deck plate.

- **Do not climb onto and off the deck plate– use steps and grab handle provided. If there is no deck plate, or if proper steps and grab handles aren't provided, don't climb onto the area behind the cab. Peterbilt did not intend for the area to be a step if handrails or proper steps are not provided.**



NOTE: Any alteration (adding bulkheads, headache racks, tool boxes, etc.) that affects the utilization of grab handles, deck plates, or frame access steps installed by Peterbilt must comply with FMCSR 399.

Front Cab Guard/Ladder

The optional front cab guard/ladder is used on front-loading refuse vehicles to protect the cab from damage and to stand on in order to remove debris from above the cab.

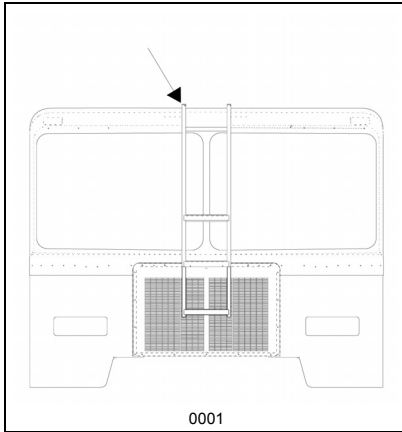

WARNING!

- ***Do not climb on the cab roof. The cab roof is not a slip-resistant surface and is not equipped with handholds. A slip and fall could cause serious injury.***
- ***Do not step or stand on the top rung of the ladder. This is not a step; it is meant to be used only as a handhold. You could slip or fall and injure yourself if you use it as a step.***

PART 3: GETTING TO YOUR ENGINE

Cab Tilting



WARNING! You can be seriously injured by the cab if you do not follow safety precautions. Whenever you raise or lower the cab, or when you work under the cab, please remember the following safety rules:

- **Be sure no one is under the front of the cab. Whether you are raising or lowering the cab, KEEP CLEAR.**
- **Never work under a raised cab unless it is properly supported. This means use an overhead hoist of sufficient capacity to support the cab safely. Never prop the cab up instead of using a hoist. The prop could fail and let the cab fall on you or anyone else working under the cab.**
- **Always be sure the safety latch is engaged when you or anyone else works under the cab.**

- **Perform work only when the cab is in the mechanically locked position or in the full tilt position.**
- **When your cab's hydraulic system needs service or repair:**
 - **Have maintenance and repair done only by someone qualified in hydraulic systems.**
 - **Be sure no one tries to bleed the system with the cab raised. This will defeat the safety system. The cab can fall and crush anyone under it.**
 - **Do not tamper with any part of the cab tilt cylinders, including removing the velocity fuses. To do so will defeat their purpose. The cab could fall and crush anyone under it. If you have any need for repair involving the velocity fuses, have a qualified truck mechanic do the work.**



NOTE: In case of oil loss in the system or a lockup in the tilt cylinders, refer to the maintenance manual for repair instructions.

Raising the Cab

An independent hydraulic system raises and lowers the cab. A positive, dual-locking device ensures safety and eliminates danger of mishaps while driving.



WARNING! Do not get any part of your body under an unsecured cab. It could cause a serious or fatal accident. The cab could fall and crush you. Always ensure the locking bar is fully engaged before getting under the cab, or before letting anyone else get under it (see following instructions on using the locking bar).



WARNING!

- ***Raising the cab with heavy objects in the cab can cause serious damage to the cab tilting mechanism and cab. Before raising the cab, remove heavy items such as tire chains and tools. Remove or stow securely any loose items. And shut the doors tightly.***

- ***Straighten the front wheels before tilting the cab or cab/tire damage could occur.***

The following cab tilting instructions are labelled and installed on the base of the companion seat:

1. Park the vehicle on a level surface.
2. Apply the parking brake.
3. Make sure the shift lever is in Neutral. This will prevent the shift lever from getting caught on the cab during tilting operations.
4. Secure or remove all loose items in the cab. Close all doors.
5. Check the clearance above and ahead of the cab. Ensure there will be enough room to clear roof antennae when you tilt the cab. Check for obstructions overhead (branches, power lines, lights, etc.) and in front (walls, work benches, other vehicles, etc.).
6. Place the control valve handle in the "Raise" position.

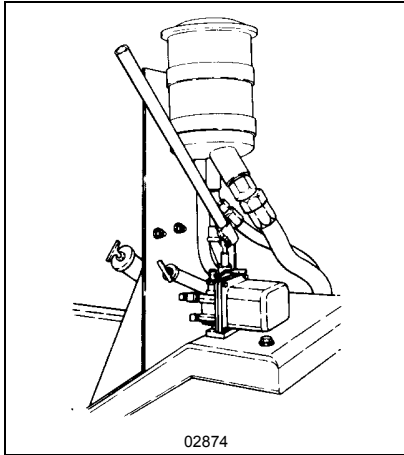

Handle in "Raise" Position

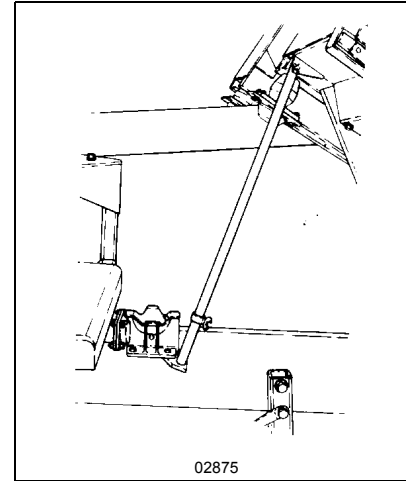

Locking Bar in Anchored Position

7. Attach pump handle to the pump and pump to raise the cab (the latch hooks will release automatically when pump is actuated). Pump until the locking bar can be positioned on the anchor mounted below the right-hand cab support as shown in the next illustration.
8. Place the control valve handle in the "Lower" position and allow the cab to settle down slightly on the locking bar.

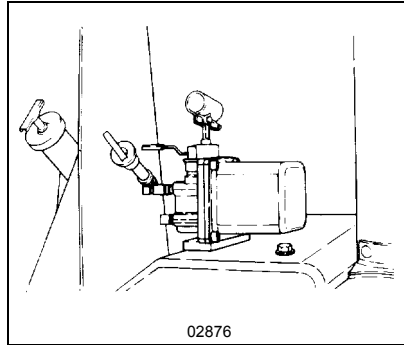

Handle in "Lower" Position

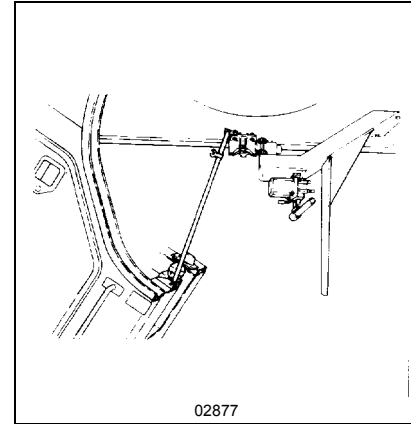

Cab in Full Tilt Position

Lowering the Cab

1. Place the control valve handle in the "Raise" position and pump until the locking bar can be removed from the anchor and fastened in its stored position.

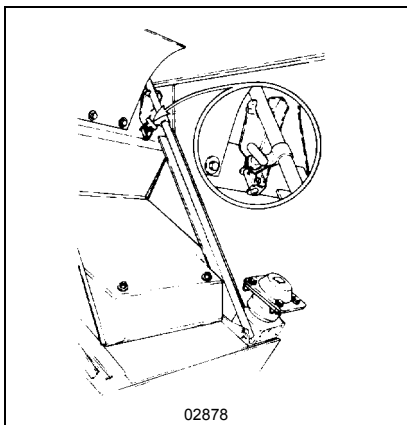

Locking Bar In Stored Position

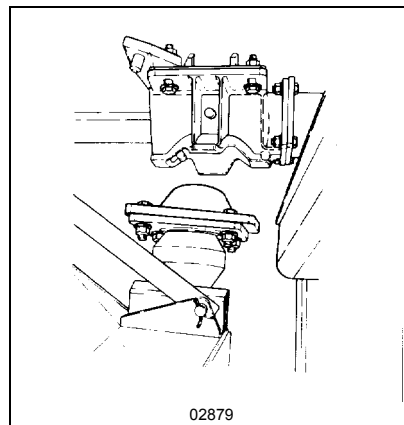

Upper and Lower Rear Cab Mount



CAUTION: Do not try to pump the cab down or hold it down with hydraulic force. If you do, cab damage will occur.

- Place the control valve handle in the "Lower" position. The cab should settle down on the rear mounts.

- Allow at least 20 seconds after the cab touches down for the full spring force to develop in the latch hooks in the rear mounts.
- Remove the pump handle and store in the cab.
- Visually inspect the cab latch hooks to ensure they are closed.
- Ensure that the control valve handle is in the "Lower" position when operating the vehicle.

PART 4: CONTROLS AND DISPLAYS

This part explains the location of the various features on your vehicle and describes their function. For information on using these features in driving, see the paragraphs that follow.

Your Instrument Panel

Please remember that each Peterbilt is custom-made. Your instrument panel may not look exactly like the one in the illustrations on the pages that follow.

We have tried to describe all the most common features and controls available, so your vehicle may not have some of the ones that appear in this section. You can pick out the parts that apply to you and read them to be fully informed on how your particular vehicle operates.

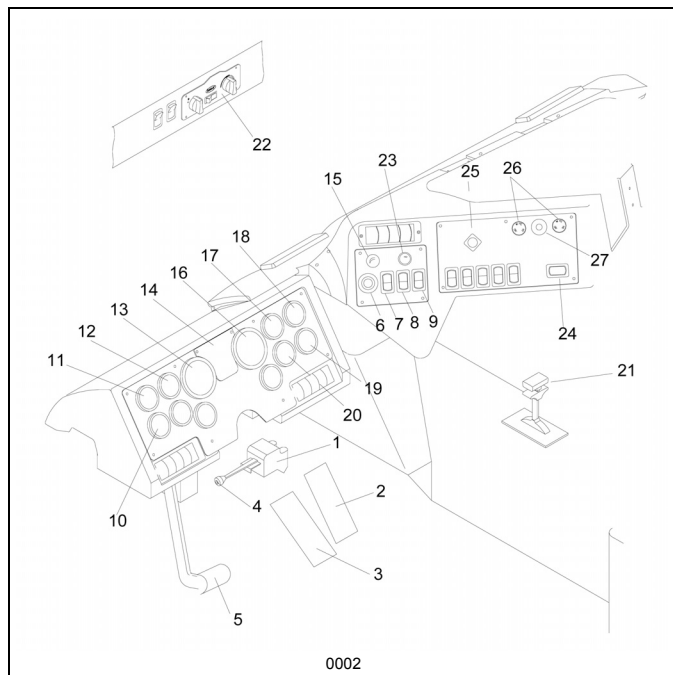

LEFT SIDE

- | | |
|--------------------------------|---|
| 1. Turn Signal/Hazard Flasher | 15. Panel Light Knob |
| 2. Accelerator Pedal | 16. Speedometer w/ Message Center (SMC) |
| 3. Brake Pedal | 17. Primary Air Pressure |
| 4. High Beam Switch | 18. Fuel |
| 5. Clutch Pedal | 19. Transmission Oil Temp. |
| 6. Ignition Key Switch | 20. Secondary Air Pressure |
| 7. Clearance Lamps Switch | 21. Gearshift or Shift Selector |
| 8. SMC Select/Reset Switch | 22. Heater Control Panel |
| 9. Headlight Switch | 23. Cigar Lighter |
| 10. Voltmeter | 24. Interaxle Differential Lock |
| 11. Engine Oil Pressure | 25. Parking Brake Valve |
| 12. Engine Coolant Temperature | 26. Windshield Wiper Valves |
| 13. Tachometer | 27. Windshield Washer Switch |
| 14. LED Warning Light Bar | |

Typical Instruments & Controls: Left-Hand Drive Station