

FOR CHASSIS BUILT AFTER 11/15/05

SH NO.	TITLE
--------	-------

- 1) INDEX SYMBOL KEY
- 2) HARNESS FLOW CHART
- 3) +12V POWER DISTRIBUTION (OPTIONAL DISCONNECT, START JUMP TERMINALS)
- 4) NEGATIVE POWER DISTRIBUTION
- 5) +12V POWER AND STARTING
- 6) WIPER / WASHER
- 7) HORN
- 8) MANUAL FAN CONTROL
- 9) HVAC CUMMINS / CATERPILLAR
- 10) TURN SIGNAL / STOP / HAZARDS / AUX TRAILER
- 11) REVERSE LAMPS
- 12) MARKER LAMPS
- 13) HEAD LAMP / DRL
- 14) FOG LAMPS
- 15) AIR DRYER
- 16) INTERFACE MODULE
- 17) SPOT LAMPS
- 18) LOAD LAMPS
- 19) FLUORESCENT LAMP SLEEPER
- 20) FLOOR LAMP
- 21) WINDOW LIFT
- 22) CENTRAL DOOR LOCKS
- 23) DOOR LAMPS / DOME LAMPS
- 24) PREMIUM SOUND
- 25) SLEEPER TOOL BOX LAMPS
- 26) SLEEPER CLOCK
- 27) AUX FAN
- 28) SLEEPER READING LAMPS
- 29) REFRIGERATOR UNIT REFER
- 30) SLEEPER POWER ACCESS OUTLETS
- 31) SLEEPER FLOOR LAMP
- 32) SLEEPER HVAC
- 33) DIGITAL MESSAGE CENTER / NAVIGATION / ROAD RELAY
- 34) E-BASIC ABS CAB HARNESS
- 35) E-BASIC ABS CHASSIS HARNESS
- 36) CAB CIGAR LIGHTER POWER CONNECTION
- 37) SPARE SWITCHES
- 38) TWO SPEED / INTER / FIFTH WHEEL / DIFF LOCK / PTO
- 39) LOW COOLANT
- 40) EATON TOP 2 TRANSMISSION
- 41) MIRROR CONTROL / HEATER / GLARESTOPPER
- 42) ENGINE BRAKE / CRUISE CONTROL / DIAGNOSTIC
- 43) RADIO
- 44) SPARE POWER SYSTEM EXPANSION SLEEPER
- 45) CATERPILLAR CUMMINS ENGINE ECU / TPS / SPEED SENSOR / INTERRUPT / WARNING LAMPS
- 46) SMC SPEEDO MESSAGE CENTER
- 47) DATA LINK
- 48) CAB SPARE POWER / SYSTEM EXPANSION
- 49) CB RADIO
- 50) BACKLIGHTING +12VOLTS
- 51) NEGATIVE SWITCH LINKS
- 52) SPLICE LOCATION - DISTRIBUTION
- 53) SPLICE LOCATION - DISTRIBUTION
- 54) ASH TRAY
- 55) FUEL HOT LINE
- 56) CAB LOAD CENTER (CLC), NOTE: NO SERVICEABLE PARTS
- 57) SLEEPER LOAD CENTER (SLC), NOTE: NO SERVICEABLE PARTS
- 58) CHASSIS LOAD CENTER DECAL
- 59) TRAILER-DECAL
- 60) SLEEPER SPARES LOAD CENTER DECAL
- 61) CAB SPARES LOAD CENTER DECAL
- 62) TRAILER LOAD CENTER
- 63) FREEDOMLINE TRANSMISSION
- 64) AUTO SHIFT
- 65) ULTRASHIFT TRANSMISSION
- 66) SWITCHED 7th WIRE HOT
- 67) EATON VORAD
- 68) WARNING LIGHTS
- 69) WARNING LIGHT BAR
- 70) SPEED SENSITIVE DIFF LOCK
- 71) REMOTE KEYLESS ENTRY INSTRUMENTATION: SEE SH # 16, 47, 68 AND 387 INSTRUMENTATION MANUAL.
- 72) SLPR LOW VOLTAGE DISCONNECT
- 73) CUMMINS ICON2 IDLE CONTROL SYSTEM

SYMBOL / ABBREVIATION KEY

- 1) ⊗ STUD
- 2) ● SPLICE
- 3) ○ RING TERMINAL CONNECTORS
- 4) NUMBERS EX CIRCUIT DESCRIPTION SUFFIX ALPHA

286	-1	A	NA
- 5) — BUSS BAR
- 6) 1 CONNECTOR APPEARS ON MULTIPLE SHEETS
- 7) CLC CHASSIS LOAD CENTER
- 8) SLPR SLEEPER
- 9) TRLR TRAILER
- 10) ———— MULTI CORE CABLE
- 11) × CONTINUED TO OTHER SH XX
- 12) ▲ MOMENTARY CONTACT

○	○	○	○
} SWITCH			
- 13) ⊕ BULB
- 14) ⊥ GROUND
- 15) —▶ DIODE
- 16) —∩— RESISTOR
- 17) —|— CAPACITOR
- 18) —∩∩— POLYFUSE
- 19) —▶ LIGHT-EMITTING DIODE

NOTE: FOR CHASSIS WITH TRAILER LOAD CENTERS (CHASSIS BUILT BEFORE 11/15/05) USE P94-6059 FOR WIRING INFORMATION

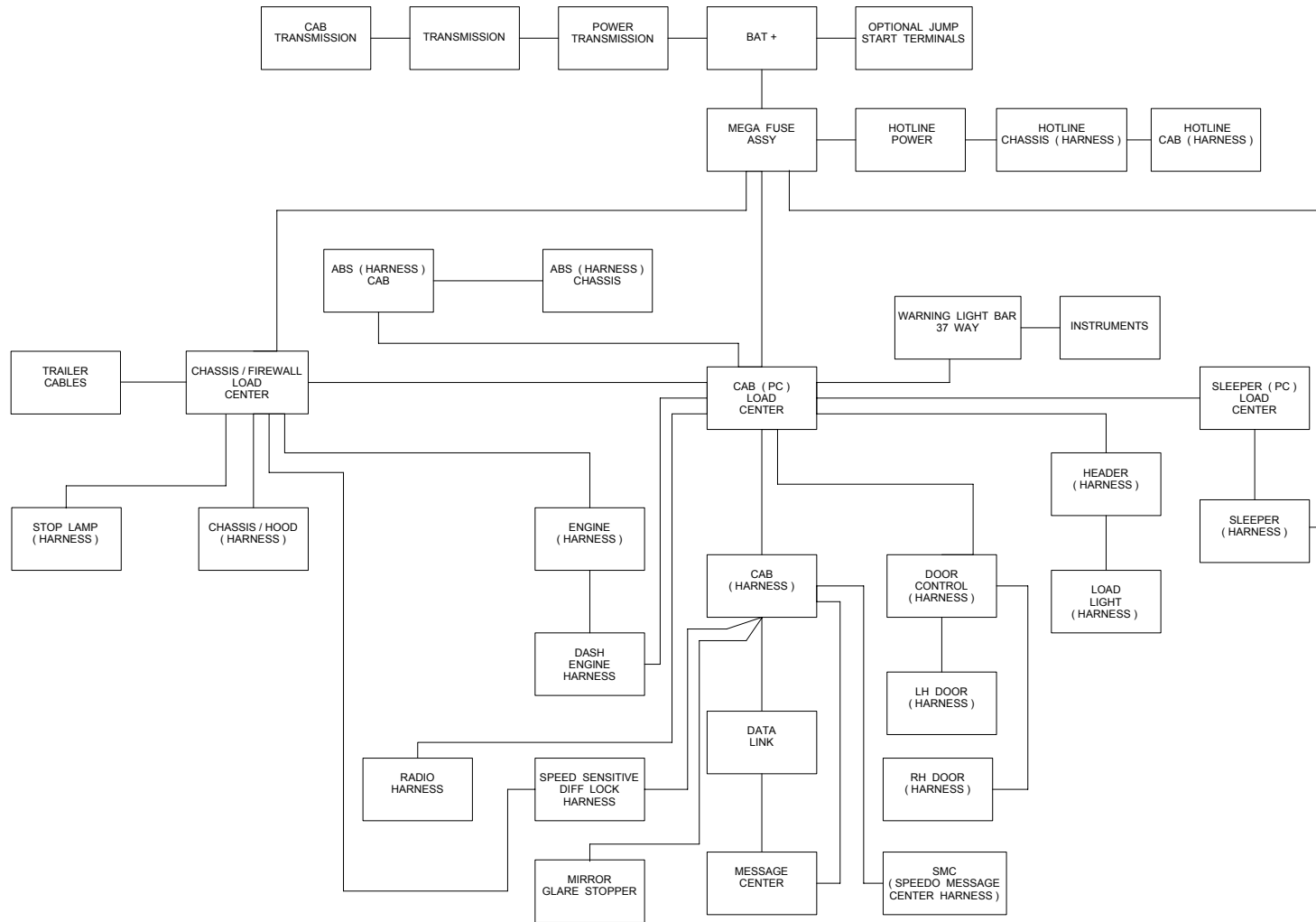

HARNES FLOW CHART



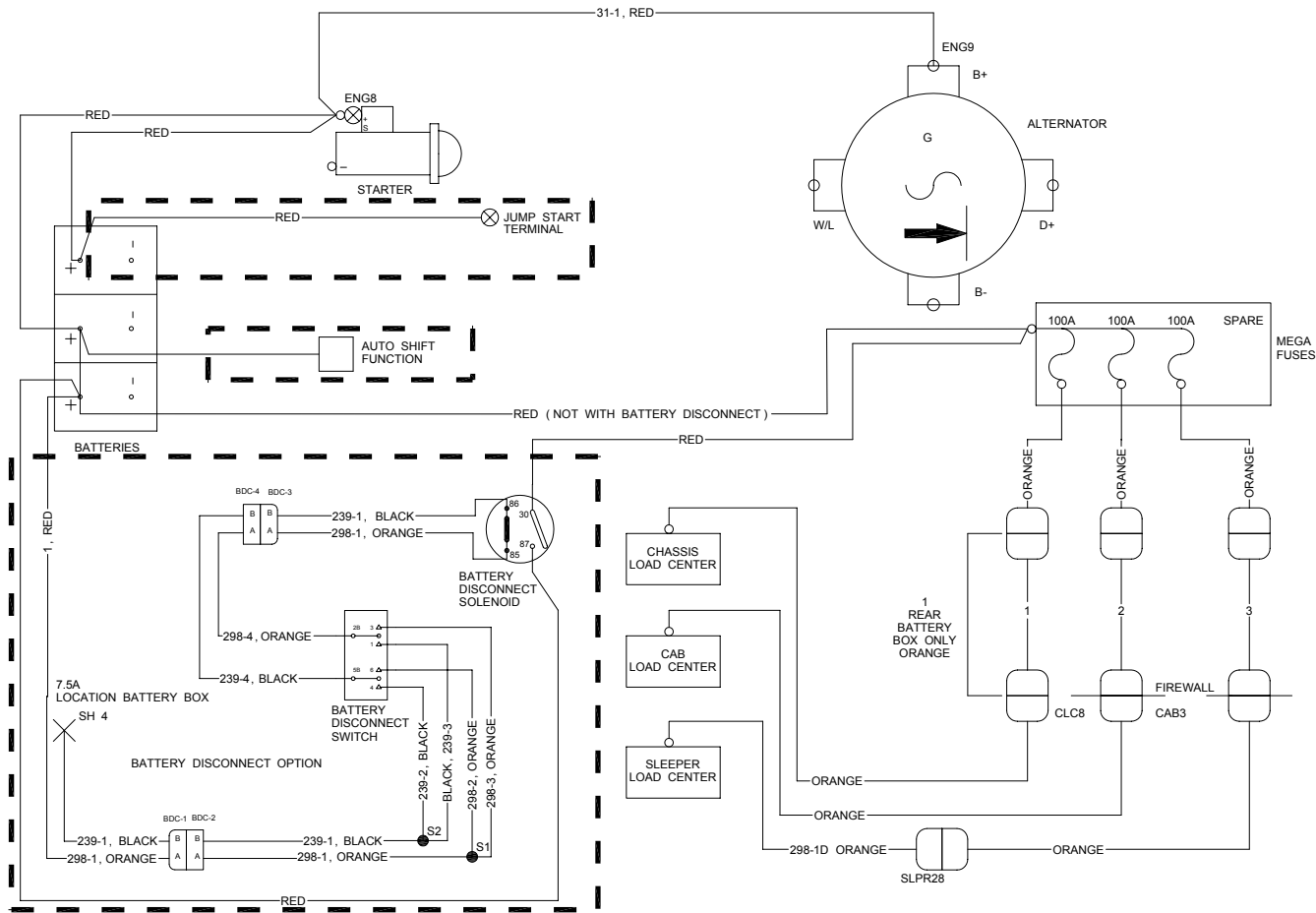

+12V POWER DISTRIBUTION (OPTIONAL DISCONNECT),
JUMP START TERMINAL

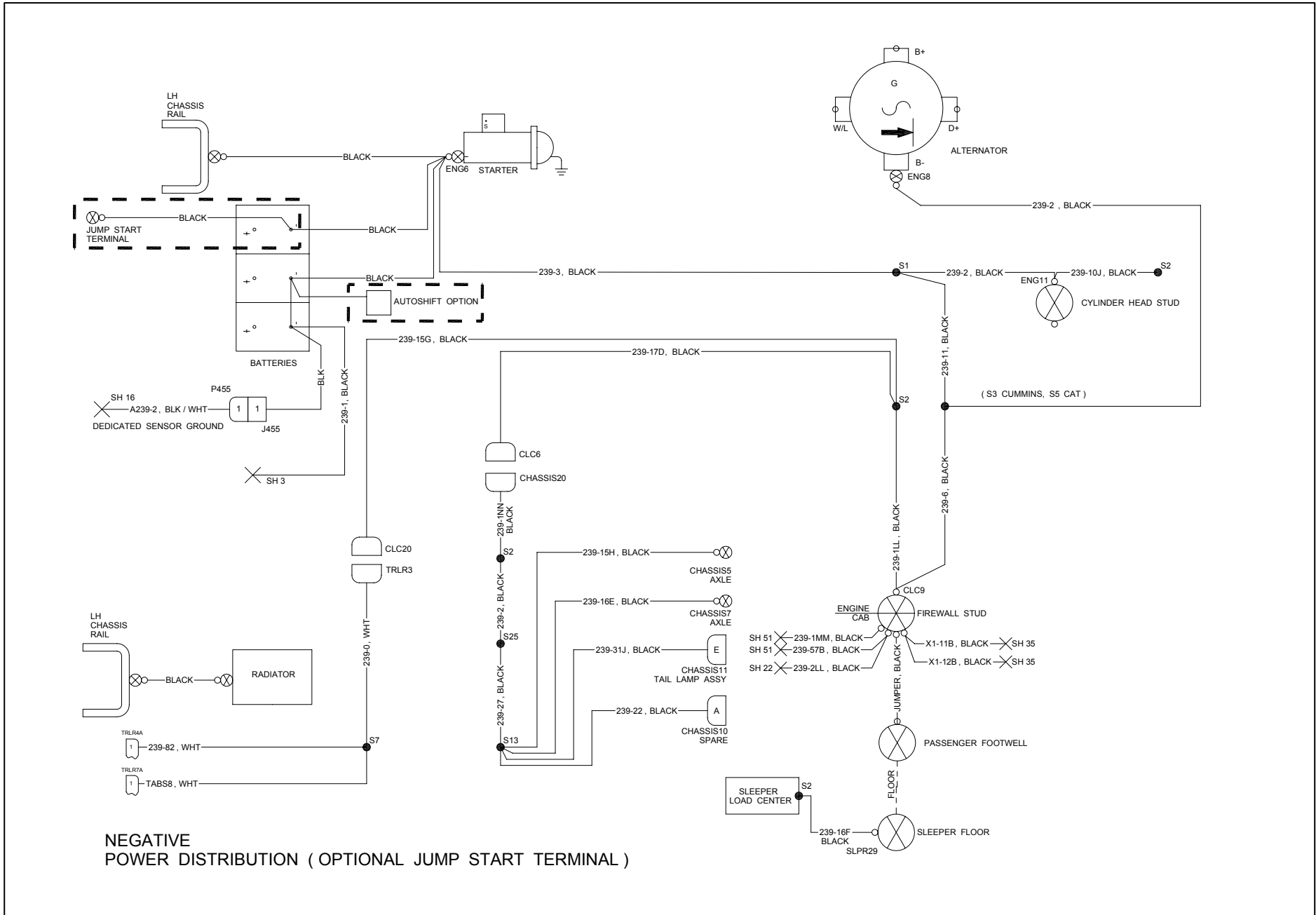

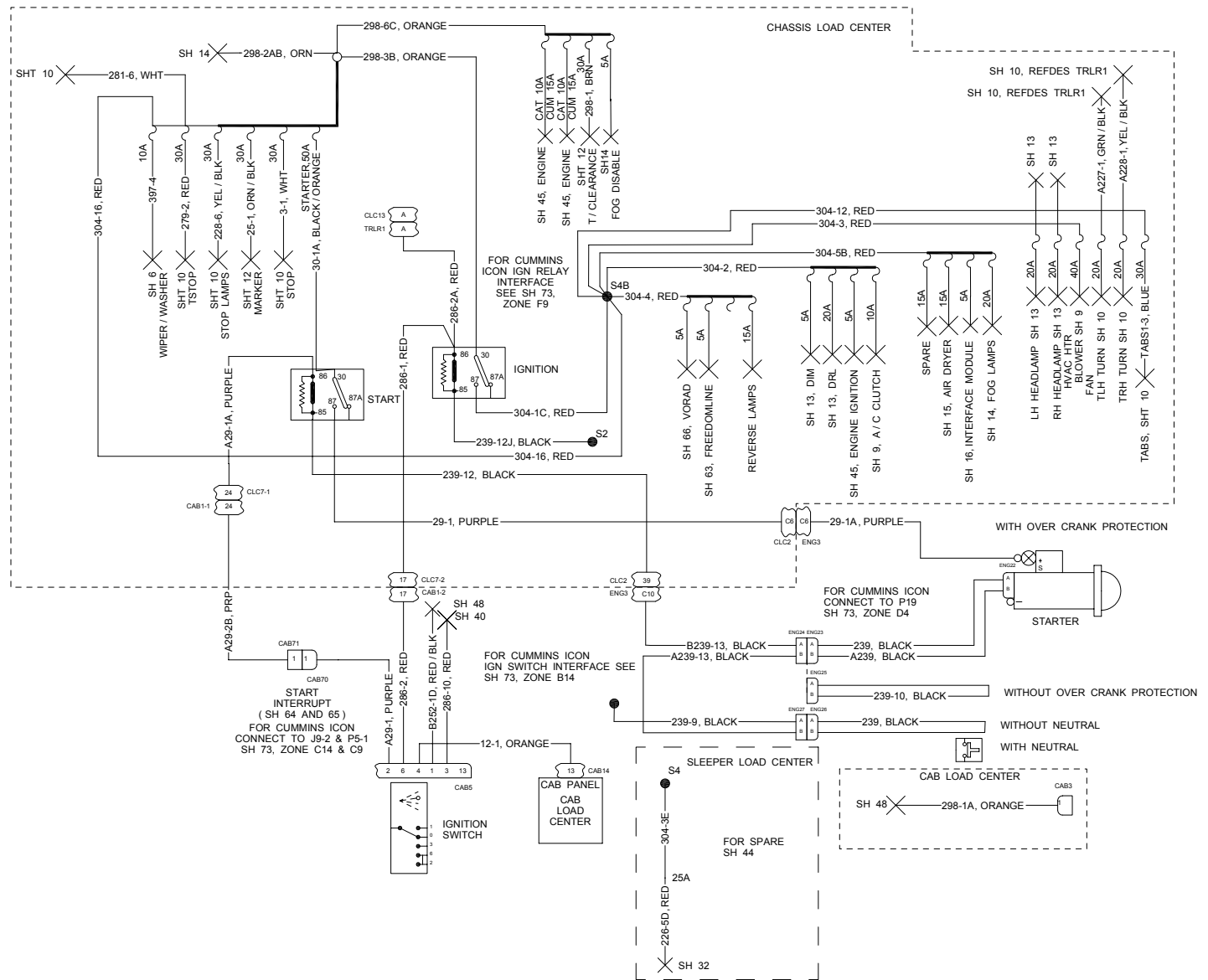

+12V POWER AND STARTING

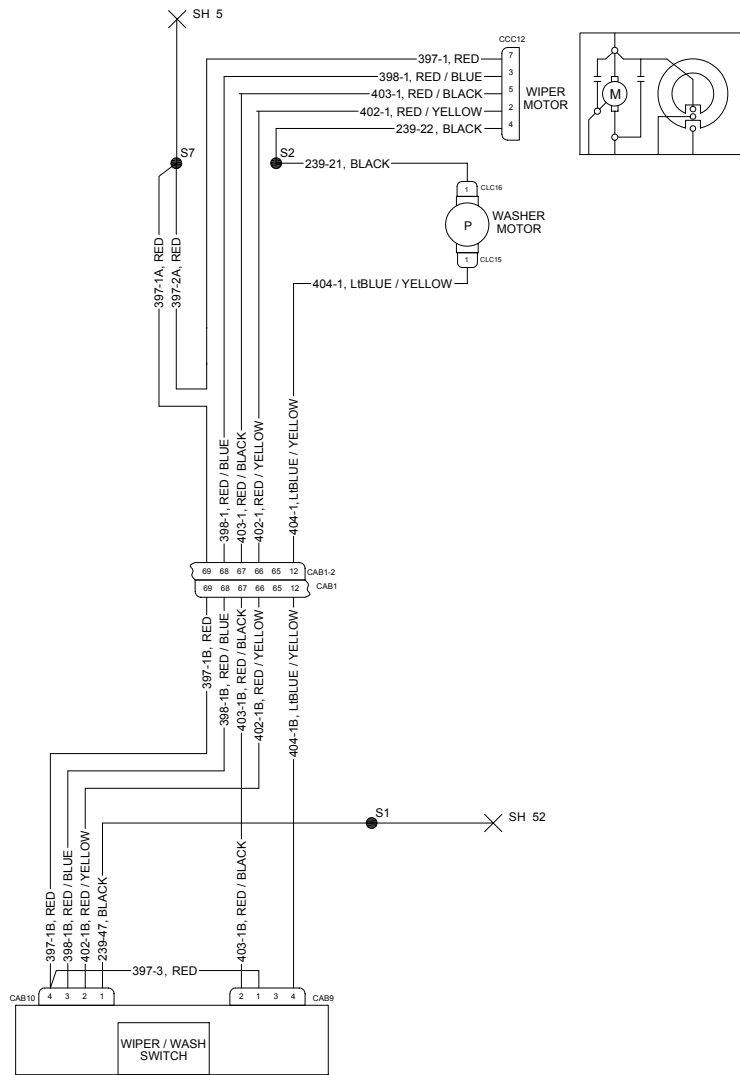

WIPER / WASHER

