

Perkins New 1000 Series

Models AJ to AS and YG to YK

WORKSHOP MANUAL

4 and 6 cylinder diesel engines for industrial and agricultural applications

Publication TPD 1350E issue 3

© Proprietary information of Perkins Engines Company Limited, all rights reserved.

The information is correct at the time of print.

Published in March 2000 by Technical Publications.



Chapters

- 10 General information**
- 11 Specifications**
- 12 Cylinder head assembly**
- 13 Piston and connecting rod assemblies**
- 14 Crankshaft assembly**
- 15 Timing case and drive assembly**
- 16 Cylinder block assembly**
- 17 Engine timing**
- 18 Aspiration system**
- 19 Lubrication system**
- 20 Fuel system**
- 21 Cooling system**
- 22 Flywheel and housing**
- 23 Electrical equipment**
- 24 Auxiliary equipment**
- 25 Special tools**

The following pages contain a detailed table of contents.

Contents

10 General information

Introduction	15
Engine identification	17
General safety precautions	18
Engine lift equipment	19
Viton seals	20
POWERPART recommended consumable products	21

11 Specifications

Basic engine data	23
Thread sealant	24
Standard torque tensions	25
Specific torque tensions	26
Compression test data	29

12 Cylinder head assembly

General description	31
Rocker cover	
12-1 To remove and to fit	32
Rocker assembly	
12-2 To remove and to fit	33
12-3 To dismantle and to assemble	34
12-4 To inspect and to correct	34
Valve tip clearances	
12-5 To check and to adjust	35
Valve springs	
12-6 To change the valve springs (with cylinder head fitted)	37
Cylinder head assembly	
12-7 To remove and to fit	39
Valves and valve springs	
12-8 To remove and to fit	49
12-9 To inspect and to correct	50
Valve guides	
12-10 To inspect	51
12-11 To remove and to fit	52
Cylinder head	
12-12 To inspect and to correct	54
12-13 To correct a valve seat with a valve seat cutter	55
12-14 To fit valve seat inserts	56
Data and dimensions	57

13 Piston and connecting rod assemblies

General description63
Big end bearing	
13-1 To remove and to fit65
13-2 To inspect66
Piston and connecting rod	
13-3 To remove and to fit67
13-4 To check the piston height above the cylinder block70
Piston rings	
13-5 To remove and to fit71
Piston and connecting rod assembly	
13-6 To dismantle and to assemble72
13-7 To check the length of a connecting rod73
Piston and piston rings	
13-8 To inspect74
Connecting rod	
13-9 To inspect75
Partially finished small end bush	
13-10 To remove and to fit75
Piston cooling jets	
13-11 To remove and to fit76
13-12 To check the jet alignment76
Data and dimensions77

14 Crankshaft assembly

General description	79
Crankshaft pulley	
14-1 To remove and to fit - four cylinder engines	80
Crankshaft pulley and damper	
14-2 To remove and to fit - six cylinder engines	81
14-3 To inspect	83
Rear oil seal assembly	
14-4 To remove and to fit	84
14-5 To renew the rear oil seal	85
Thrust washers	
14-6 To check crankshaft end-float	86
14-7 To remove and to fit	87
Main bearings	
14-8 To remove and to fit (with the crankshaft in position)	89
14-9 To inspect	90
Crankshaft	
14-10 To remove and to fit	91
14-11 To inspect	94
Balancer unit	
14-12 To remove and to fit	95
14-13 To dismantle and to assemble	96
14-14 To inspect	101
14-15 To remove and to fit the needle roller bearings for the drive shaft	102
14-16 To remove and to fit the bushes for the balance weights	103
Data and dimensions	104

15 Timing case and drive assembly

General description	109
Timing case cover	
15-1 To remove and to fit	110
Front oil seal	
15-2 To remove and to fit	111
15-3 To fit wear sleeve	112
Idler gear and hub	
15-4 To remove and to fit	113
Idler gear and hub for the Bendix compressor	
15-5 To remove and to fit	116
Fuel pump gear	
15-6 To remove and to fit	118
Camshaft gear	
15-7 To remove and to fit	120
Crankshaft gear	
15-8 To remove and to fit	121
Timing case	
15-9 To remove and to fit	122
Camshaft and tappets	
15-10 To remove and to fit	124
Data and dimensions	125

16 Cylinder block assembly

General description	127
Cylinder block	
16-1 To dismantle and to assemble	128
16-2 To inspect	129
Cylinder liner	
16-3 To inspect	130
16-4 To remove and to fit	131
Cylinder bore, engine types AR and AS	
16-5 To inspect	136
Data and dimensions	137

17 Engine timing

General description	141
Engine timing	
17-1 To set number 1 piston to TDC on the compression stroke	143
17-2 Another method to set number 1 piston to TDC on the compression stroke	144
17-3 To check the valve timing	144
17-4 To check the timing of the fuel injection pump	145
Data and dimensions	146

18 Aspiration system

General description	147
Turbocharger	
18-1 To remove and to fit	149
18-2 To clean the impeller and the compressor casing	151
18-3 To remove and to fit the actuator assembly of the waste-gate unit	152
18-4 To check and adjust the operation of the waste-gate	153
Turbocharger faults	154
Engine breather	
18-5 To clean and to renew	156
18-6 To clean and to renew	157

Data and dimensions	158
----------------------------------	-----

19 Lubrication system

General description	159
----------------------------------	-----

Filter canister

19-1 To renew	163
---------------------	-----

Filter head

19-2 To remove and to fit	164
---------------------------------	-----

Sump

19-3 To remove and to fit	165
---------------------------------	-----

Oil strainer and suction pipe

19-4 To remove and to fit	165
16-5 To inspect and to correct	166

Lubricating oil pump

19-6 To remove and to fit	167
19-7 To renew the shaft for the idler gear	169
19-8 To inspect	173

Relief valve

19-9 To remove and to fit	174
19-10 To dismantle and to assemble	175
19-11 To inspect	175

Flexible oil pipes

19-12 To remove, to fit and to inspect	176
--	-----

Data and dimensions	178
----------------------------------	-----

Fuel system

General description	181
Cold start advance unit	183
Typical fuel system	186
Fuel filters	187
Fuel filter element	
20-1 To renew	188
Atomisers	
20-2 Atomiser fault	191
20-3 To remove and to fit	191
Fuel lift pump	
20-4 To remove and to fit	193
20-5 To dismantle and to assemble	194
20-6 To test	195
Bosch fuel injection pump	
20-7 To remove and to fit	196
20-8 To adjust	200
20-9 To eliminate air from the fuel system	201
Lucas DP 200 Series fuel injection pump	
20-10 To remove to fit	203
20-11 To adjust	207
20-12 To eliminate air from the fuel system Lucas DP200 pump	208
Stanadyne fuel injection pump	
20-13 To remove to fit	210
20-14 To adjust	214
20-15 To eliminate air from the fuel system	215
Data and dimensions	217

21 Cooling system

General description	219
Thermostats	
21-1 To remove, to fit and to test	220
Coolant pump - early gear driven pumps	
21-2 To remove and to fit	221
Coolant pump - latest gear driven pumps	
21-3 To remove and to fit	222
Coolant pump - belt driven	
21-4 To remove and to fit	224
Coolant pump - belt driven high position	
21- 5 To remove and to fit	226
Coolant pump - early gear driven pumps	
21-6 To dismantle and to assemble	229
Coolant pump - latest gear driven pumps	
21-7 To dismantle and to assemble	232
Coolant pump - belt driven	
21-8 To dismantle and to assemble	237
Fan	
21-9 To remove and to fit	240
Fan drive (engines with gear driven coolant pumps)	
21-10 To remove and to fit	240
Lubricating oil cooler	
21-11 To remove and to fit - four cylinder turbocharged engines	241
21-12 To remove and to fit - six cylinder engines	242
21-13 To remove and to fit - pressed steel cover type	243
21-14 To remove and to fit - canister type..	245
21-15 To dismantle and to assemble - four cylinder turbocharged engines	246
21-16 To dismantle and to assemble - six cylinder turbocharged engines	247
Cooler by-pass valve	
21-17 To remove and to fit	247
21-18 To dismantle and to assemble pressed steel cooler type	248

Intercooler

21-19 To remove and to fit	250
21-20 To clean and to inspect	254

Data and dimensions	255
----------------------------------	-----

22 Flywheel and housing

General description	257
----------------------------------	-----

Flywheel

22-1 To remove and to fit	258
---------------------------------	-----

Ring gear

22-2 To remove and to fit	258
---------------------------------	-----

Flywheel housing

22-3 To remove and to fit	259
---------------------------------	-----

Data and dimensions	260
----------------------------------	-----

23 Electrical equipment

Alternators

General description 261

Precautions 261

Drive belts

23-1 To check 262

23-2 To adjust tension 262

23-3 To remove and to fit 262

Alternator

23-4 To remove and to fit 263

23-5 To maintain 263

Fault diagnosis

Data and dimensions 266

Starter motors

General description 267

Starter motor

23-6 To remove and to fit 268

23-7 To maintain the brush gear and the commutator 269

23-8 To test on the engine 269

Data and dimensions 270

Starting aid

General description 271

Starting aid 271

23-9 To remove and to fit a fuelled starting aid 271

23-10 To remove and to fit a port heater 273

Data and dimensions 274

24 Auxiliary equipment

Compressors

General description	275
Operation	275
Bendix Compressors	
24-1 To remove and to fit	276
Data and dimensions	279
Power steering pump	
24-2 To remove and to fit	280
Adaptor for a hydraulic pump or a steering pump with a splined drive	
24-3 To remove and to fit	281
24-4 To dismantle and to assemble	281
Exhauster	
24-5 To remove and to fit	283

25 Special tools

List of special tools	286
------------------------------------	-----

10

General information

Introduction

This workshop manual has been written to provide assistance in the service and overhaul of Perkins New 1000 Series engines. For overhaul procedures the assumption is made that the engine is removed from the application. The engine conforms with USA (EPA/CARB) stage 1 and EEC stage 1 emissions legislation for agricultural and industrial applications.

Most of the general information which is included in the relevant User's Handbook (sections 1 to 9) has not been repeated in this workshop manual and the two publications should be used together.

Where the information applies only to certain engine types, this is indicated in the text.

The details of some operations will be different according to the of fuel injection pump which is fitted. The specific pump type used can be found by reference to the manufacturer's identification plate on the pump body. Generally, the type of pump fitted is as shown below.

Lucas	DP200 Series
Bosch	EPVE
Stanadyne	DB4

When reference is made to the "left" or "right" side of the engine, this is as seen from the flywheel end of the engine.

Special tools have been made available and a list of these is given in [section 25](#). Reference to the relevant special tools is also made at the beginning of each operation, where relevant.

POWERPART recommended consumable products are listed [on page 21](#). Reference to the relevant consumable products is also made at the beginning of each operation, where relevant.

Data and dimensions are included at the end of each section.

Read and remember the "Safety precautions". They are given for your protection and must be used at all times.

Danger is indicated in the text by two methods:

Warning! *This indicates that there is a possible danger to the person.*

Caution: *This indicates that there is a possible danger to the engine.*

Note: Is used where the information is important, but there is not a danger.

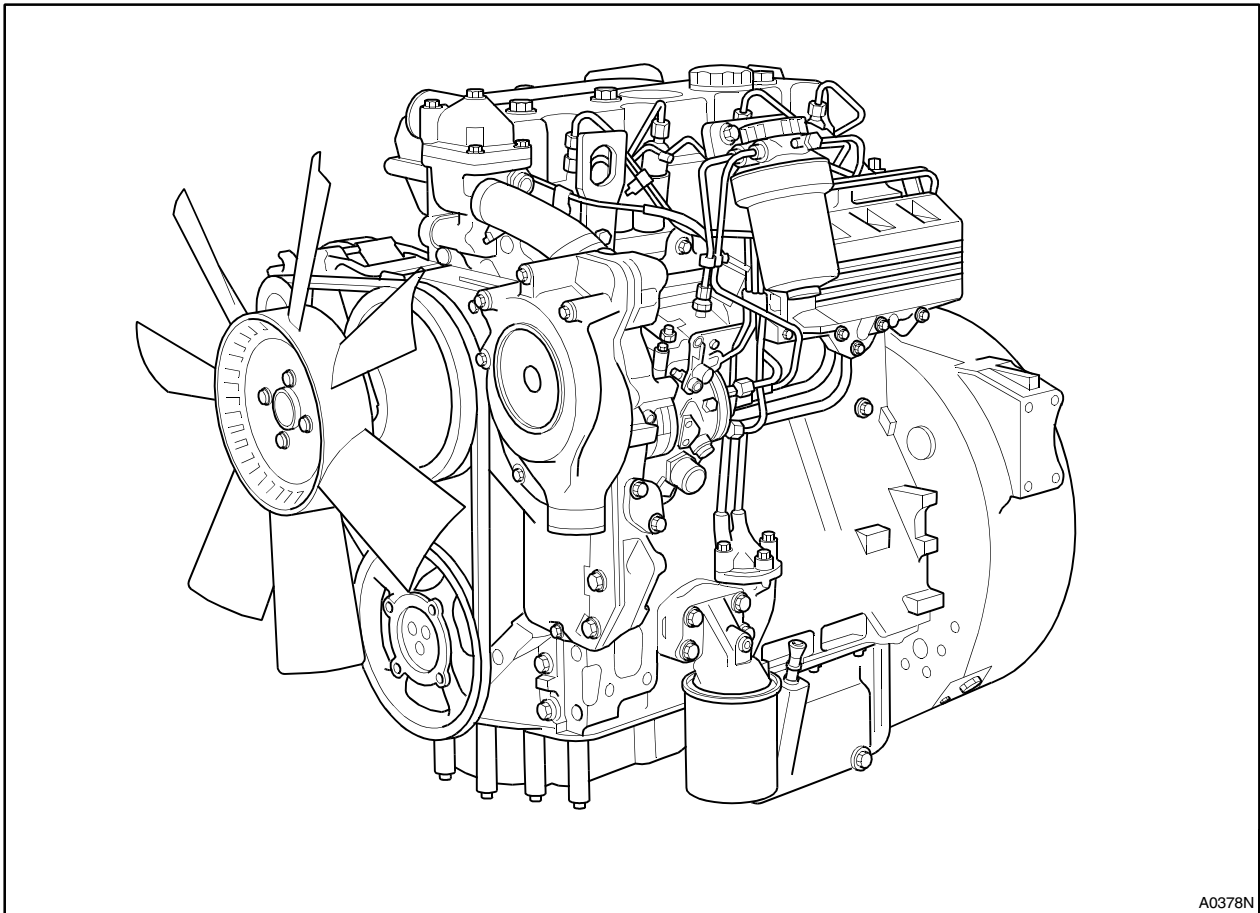

A0378N

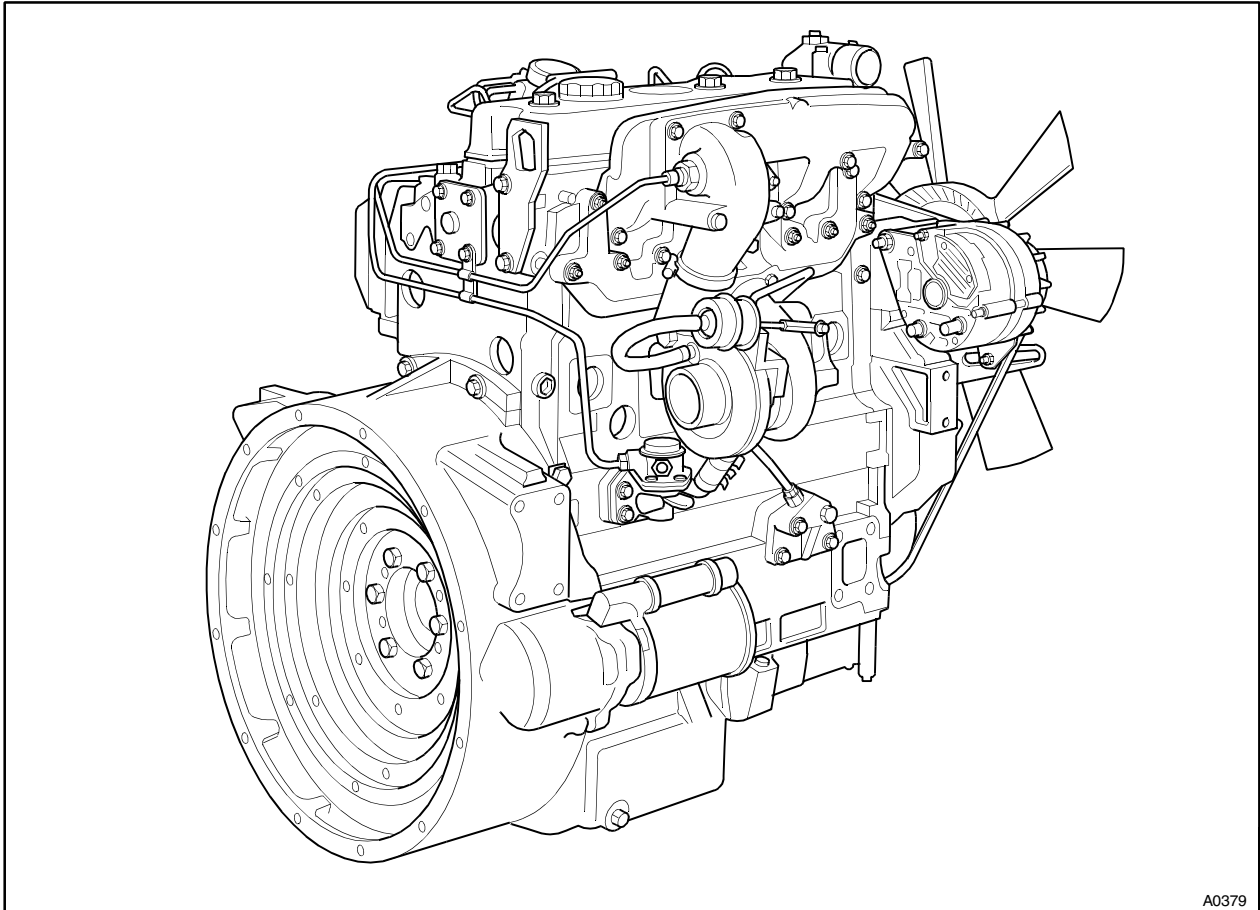

A0379

Engine identification

The Perkins New 1000 Series engines have been designed for industrial and agricultural applications. There are both four and six cylinder engines, each of which will have three basic engine types, naturally aspirated, turbocharged and turbocharged with an intercooler.

In this workshop manual, the different engine types are indicated by their code letters. These are the first two letters of the engine number as indicated below:

Code letters	Engine type
AJ	Four cylinder, naturally aspirated.
AK	Four cylinder, turbocharged.
AM	Four cylinder, turbocharged and intercooled.
AP	Four cylinder, naturally aspirated, belt driven coolant pump.
AQ	Four cylinder, turbocharged, belt driven coolant pump.
AR	Four cylinder, naturally aspirated, 103 mm cylinder bore.
AS	Four cylinder, naturally aspirated, belt driven coolant pump, 103 mm cylinder bore.
YG	Six cylinder, naturally aspirated.
YH	Six cylinder, turbocharged.
YK	Six cylinder, turbocharged and intercooled.

The correct identification of the engine is by the full engine number.

The engine number is stamped on a label which is fastened to the left side (A2) of the cylinder block. An example of an engine number is:

AK80920*U510256B*

If you need parts, service or information for your engine, you must give the complete engine number to your Perkins distributor. If there is a number in the area of the label marked TPL N^o, then this number must also be given to your Perkins distributor.

Other identification labels fitted to the engine include:

An emissions legislation label (A3) fitted to the side of the cylinder block.

A label (A1) with the fuel injection pump part numbers.

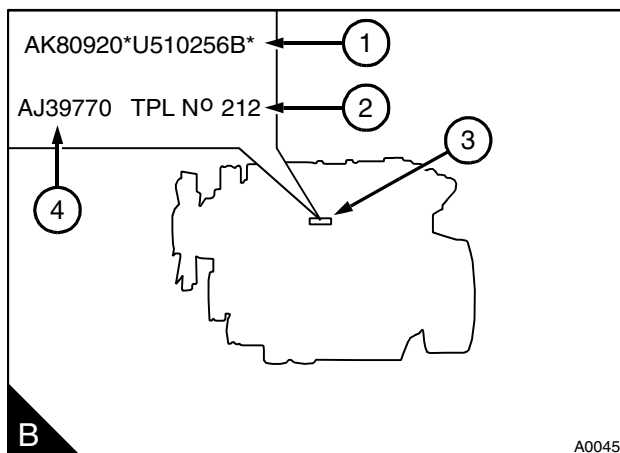
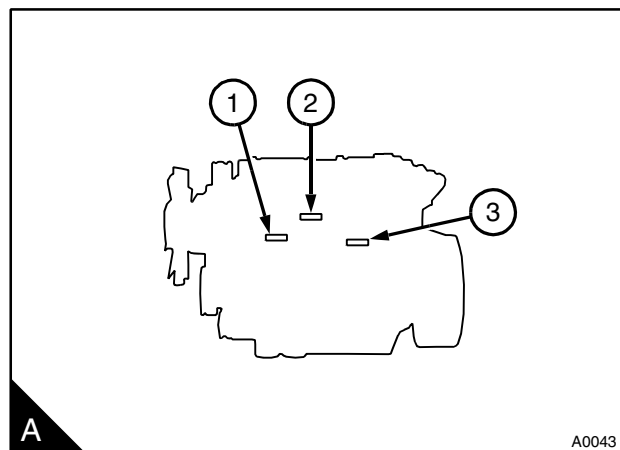

If a short engine has been fitted in service two engine serial numbers and a TPL number are stamped on the engine serial number pad (B3):

Examples of the serial numbers are shown in (B).

If parts for the short engine are needed in service, use the serial number (B4). If parts which were moved from the original engine to the short engine are needed, use the serial number (B1) and the TPL number (B2).

General safety precautions

These safety precautions are important. You must refer also to the local regulations in the country of use. Some items only refer to specific applications.

- Only use these engines in the type of application for which they have been designed.
- Do not change the specification of the engine.
- Do not smoke when you put fuel in the tank.
- Clean away fuel which has been spilt. Material which has been contaminated by fuel must be moved to a safe place.
- Do not put fuel in the tank while the engine runs (unless it is absolutely necessary).
- Do not clean, add lubricating oil, or adjust the engine while it runs (unless you have had the correct training; even then extreme care must be used to prevent injury).
- Do not make adjustments that you do not understand.
- Ensure that the engine does not run in a location where it can cause a concentration of toxic emissions.
- Other persons must be kept at a safe distance while the engine or auxiliary equipment is in operation.
- Do not permit loose clothing or long hair near moving parts.
- Keep away from moving parts during engine operation. **Warning!** *Some moving parts cannot be seen clearly while the engine runs.*
- Do not operate the engine if a safety guard has been removed.
- Do not remove the filler cap or any component of the cooling system while the engine is hot and while the coolant is under pressure, because dangerous hot coolant can be discharged.
- Do not use salt water or any other coolant which can cause corrosion in the closed circuit of the cooling system.
- Do not allow sparks or fire near the batteries (especially when the batteries are on charge) because the gases from the electrolyte are highly flammable. The battery fluid is dangerous to the skin and especially to the eyes.
- Disconnect the battery terminals before a repair is made to the electrical system.
- Only one person must control the engine.
- Ensure that the engine is operated only from the control panel or from the operators position.
- If your skin comes into contact with high-pressure fuel, obtain medical assistance immediately.
- Diesel fuel and lubricating oil (especially used lubricating oil) can damage the skin of certain persons. Protect your hands with gloves or a special solution to protect the skin.
- Do not wear clothing which is contaminated by lubricating oil. Do not put material which is contaminated with oil into the pockets of clothing.
- Discard used lubricating oil in a safe place to prevent contamination.
- Ensure that the control lever of the transmission drive is in the "out-of-drive" position before the engine is started.
- Use extreme care if emergency repairs must be made in adverse conditions.
- The combustible material of some components of the engine (for example certain seals) can become extremely dangerous if it is burned. Never allow this burnt material to come into contact with the skin or with the eyes, [see page 20](#).
- Read and use the instructions relevant to lift equipment which are given [on page 19](#).
- Always use a safety cage to protect the operator when a component is to be pressure tested in a container of water. Fit safety wires to secure the plugs which seal the hose connections of a component which is to be pressure tested.
- Do not allow compressed air to contact your skin. If compressed air enters your skin, obtain medical help immediately.
- Turbochargers operate at high speed and at high temperatures. Keep fingers, tools and items away from the inlet and outlet ports of the turbocharger and prevent contact with hot surfaces.
- Do not clean an engine while it runs. If cold cleaning fluids are applied to a hot engine, certain components on the engine may be damaged.
- Fit only genuine Perkins parts.

Engine lift equipment

The maximum weight of the engine without coolant, lubricant or a gearbox fitted will vary for different applications. It is recommended that lift equipment of the minimum capacity listed below is used:

Four cylinder engines 500 kg (1100 lbs)

Six cylinder engines. 600 kg (1320 lbs)

Before the engine is lifted:

- Always use lift equipment of the approved type and of the correct capacity to lift the engine. It is recommended that lift equipment of the type shown in (A) is used, to provide a vertical lift directly above the engine lift brackets (A1). Never use a single lift bracket to raise an engine.
- Check the engine lift brackets for damage and that they are secure before the engine is lifted. The torque for the setscrews for the engine lift brackets is 44 Nm (33 lbf ft) 4,5 kgf m.
- To prevent damage to the rocker cover, ensure that there is clearance between the hooks and the rocker cover.
- Use lift equipment or obtain assistance to lift heavy engine components such as the cylinder block, cylinder head, balancer unit, flywheel housing, crankshaft and flywheel.

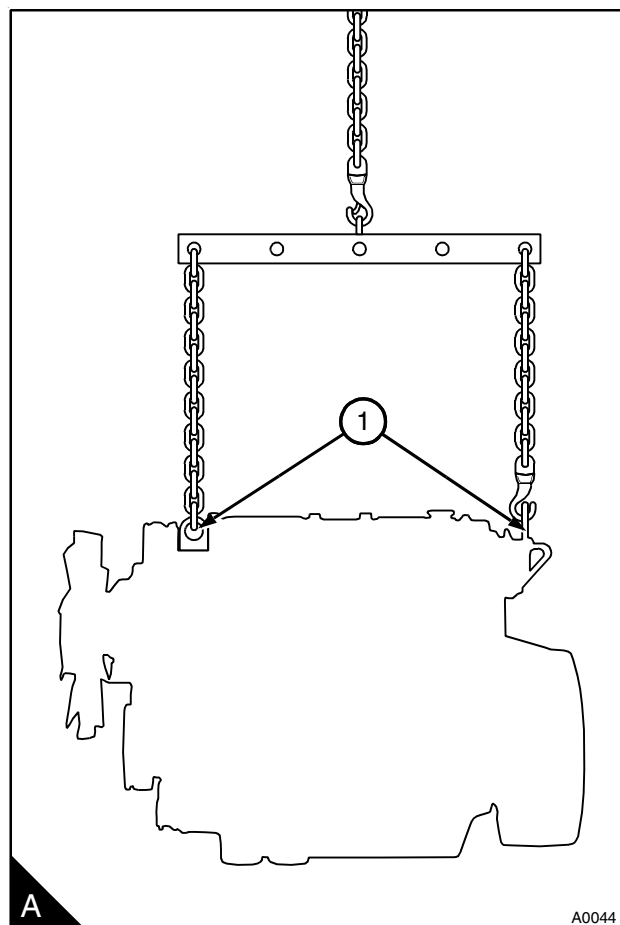

Viton seals

Some seals used in engines and in components fitted to engines are made of Viton.

Viton is used by many manufacturers and is a safe material under normal conditions of operation.

If Viton is burned, a product of this burnt material is an acid which is extremely dangerous. Never allow this burnt material to come into contact with the skin or with the eyes.

If it is necessary to come into contact with components which have been burnt, ensure that the precautions which follow are used:

- Ensure that the components have cooled.
- Use neoprene gloves and discard the gloves safely after use.
- Wash the area with calcium hydroxide solution and then with clean water.
- Disposal of components and gloves which are contaminated must be in accordance with local regulations.

If there is contamination of the skin or eyes, wash the affected area with a continuous supply of clean water or with calcium hydroxide solution for 15-60 minutes. Obtain immediate medical attention.