

Massey Ferguson

165

TRACTOR/TRACTEUR SCHLEPPER/TRACTOR

819 536 M5

Includes All Modifications Issued Up To And Including Release And Change Bulletin No. 682

THIS BOOK IS PRINTED IN TWO SECTIONS. THE FIRST SECTION CONTAINS A PICTORIAL AND GROUP INDEX PLUS A NUMERICAL INDEX OF ALL PART NUMBERS INCLUDED IN THIS BOOK. THE PAGES IN THIS SECTION ARE NUMBERED WITH ROMAN NUMERALS.

THE SECOND SECTION INCLUDES A PART NUMBER LISTING, REFERENCED TO ITEM NUMBERS ON THE ILLUSTRATED PAGE DIRECTLY OPPOSITE. PAGES IN THIS SECTION ARE NUMBERED WITH ARABIC NUMERALS.

THE PAGE NUMBERS APPEAR IN THE UPPER OUTER CORNER OF THE PAGE. PARTS BOOK NUMBER AND DATE APPEAR IN THE LOWER RIGHT HAND CORNER OF THE PAGE. ALL PAGES WILL ALSO CARRY THE MACHINE NAME TO ASSIST IN IDENTIFYING THE MACHINE TO WHICH THE PARTS BOOK APPLIES.

WHEN CHANGES TO THE MACHINE OCCUR, THE INFORMATION WILL BE ISSUED IN THE FORM OF A "PARTS RELEASE AND CHANGE BULLETIN". INFORMATION FROM THESE BULLETINS SHOULD BE ENTERED IN THE APPROPRIATE PAGES AS SOON AS THE BULLETINS ARE RECEIVED.

FROM TIME TO TIME NEW OR REVISED PAGES FOR THIS BOOK WILL BE ISSUED. THE REVISED PAGES WILL CARRY THE SAME PAGE NUMBERS AS THOSE THEY REPLACE. NEW PAGES WILL CARRY AN EXISTING PAGE NUMBER WITH AN ALPHA SUFFIX, THESE WILL BE INSERTED IN THE PARTS BOOK FOLLOWING THE EXISTING PAGE. THE ISSUE NUMBER AND DATE WILL BE ADVANCED FOR NEW AND REVISED PAGES AND THE EFFECTIVE PARTS RELEASE AND CHANGE BULLETIN NUMBER WILL BE INDICATED AT THE FOOT OF EACH PAGE.

IT IS IMPERATIVE THAT NEW AND REVISED PARTS BOOK PAGES BE INSERTED INTO THEIR RESPECTIVE PARTS BOOKS AS SOON AS THEY ARE RECEIVED. FAILURE TO DO SO WILL LEAD TO CONFUSION AND DEFEAT THE PURPOSE OF THE BOOK.

INDENTED PARTS IN THE DESCRIPTIVE LIST ARE A PART OF THE PRECEDING ASSEMBLY OR SUB-ASSEMBLY.

THE QUANTITY SHOWN IN THE "NUMBER REQUIRED" COLUMN IS THE NUMBER OF PARTS USED ON A MACHINE, EXCEPT WHERE PARTS ARE INDENTED IN THE DESCRIPTIVE LIST. IN THIS CASE THE QUANTITY SHOWN IS THE NUMBER REQUIRED FOR THE PRECEDING ASSEMBLY OR SUB-ASSEMBLY.

FOR CERTAIN PARTS, SUCH AS KITS, SHIMS, ETC., AN "X" WILL BE SHOWN IN THE "NUMBER REQUIRED" COLUMN. THIS "X" INDICATES THAT THE QUANTITY IS "AS REQUIRED".

CE CATALOGUE EST IMPRIME EN 2 PARTIES. LA PREMIERE PARTIE COMPORTE UN INDEX VISUEL, UNE TABLE DES MATIERES ET UN INDEX NUMERIQUE DE TOUS LES NUMEROS DE PIECES INSCRITS DANS CE CATALOGUE. LES PAGES DE CETTE PREMIERE PARTIE SONT NUMEROTEES EN CHIFFRES ROMAINS.

LA SECONDE PARTIE COMPORTE LES DESSINS D'ILLUSTRATION ET SUR LA PAGE VOISINE, LA LISTE DE PIECES SE RAPPORTANT A CES DESSINS. LES PAGES DE CETTE PARTIE SONT NUMEROTEES EN CHIFFRES ARABES.

LES NUMEROS DES PAGES SONT INSCRITS SUR LE COIN INTERIEUR ET EXTERIEUR DE CHAQUE PAGE. LE NUMERO DU CATALOGUE, LE NUMERO D'EMISSION ET LA DATE APPARAISSENT DANS LE COIN INFERIEUR DROIT DES PAGES. CHAQUE PAGE PORTE EGALEMENT LE NOM DE LA MACHINE.

LORSQUE DES MODIFICATIONS INTERVIENDRONT, LES RENSEIGNEMENTS SERONT DIFFUSES PAR LE CANAL DES "BULLETINS DE CHANGEMENTS". CES RENSEIGNEMENTS DEVRONT ETRE NOTES SUR LE CATALOGUE DES RECEPTION.

PERIODIQUEMENT DE NOUVELLES PAGES DE CE CATALOGUE SERONT EDITEES. LES PAGES REVISEES PORTERONT LE MEME NUMERO DE PAGE QUE CELLES QU'ELLES REMPLACENT, SEULS LE NUMERO D'EMISSION ET LA DATE SERONT MODIFIES. LES PAGES SUPPLEMENTAIRES PORTANT LE NUMERO D'UNE PAGE EXISTANTE SUIVI D'UN SUFFIXE ALPHABETIQUE SERONT INSEREES A LA SUITE DE CETTE PAGE. LE NUMERO DES BULLETINS DE CHANGEMENT FIGURERONT AU BAS DE CHAQUE PAGE.

IL EST IMPERATIF D'INSERER CES PAGES RECTIFICATIVES OU ADDITIVES DES RECEPTION. NE PAS LE FAIRE, CONDUIT A LA CONFUSION ET ENLEVE TOUT L'INTERET DE CE CATALOGUE.

LES PIECES DONT LES DESIGNATIONS SONT INSCRITES EN RETRAIT FONT PARTIE DE L'ENSEMBLE OU DU SOUS-ENSEMBLE LES PRECEDANT.

LE NOMBRE INDIQUE EN COLONNE "QUANTITE" EST CELUI DES PIECES UTILISEES SUR UNE MACHINE, SAUF POUR LES PIECES DONT LES DESIGNATIONS SONT INSCRITES EN RETRAIT. DANS CE CAS LA QUANTITE INSCRITE INDIQUE LE NOMBRE DE PIECES COMPRISES DANS L'ENSEMBLE OU LE SOUS-ENSEMBLE LES PRECEDANT.

POUR CERTAINES PIECES, COMME LES JEUX, LES CALES, ETC... DONT LA QUANTITE PEUT VARIER LE NOMBRE SERA INDIQUE PAR UN "X"

DIESE ERSATZTEILLISTE IST IN ZWEI ABSCHNITTE EINGETEILT. DER ERSTE ABSCHNITT ENHAELT BAUGRUPPENVERZEICHNIS, ALPHABETISCHES INHALTSVERZEICHNIS UND NUMMERNINDEX. DIESE SEITEN SIND MIT ROEMISCHEN ZIFFERN NUMERIERT.

DER ZWEITE TEIL ENTHAELT AUF DEN LINKEN SEITEN EINE BILDICHE DARSTELLUNG DER EINZELNEN BAUGRUPPEN UND AUF DEN RECHTEN SEITEN DIE ENTSPRECHENDEN TEILNUMMERN UND DIE BESCHREIBUNG. DIESE SEITEN SIND MIT ARABISCHEN ZIFFERN NUMERIERT.

DIE SEITENZAHLN STEHEN IN DEN OBEREN AUSSEREN ECKEN DER SEITEN. TEILNUMMER UND AUSGABEDATUM DER ERSATZTEILLISTE SIND UNTEN RECHTS AUFGEFUEHRT. AUSSERDEM IST IN DER MITTE UNTEN DIE BEZEICHNUNG DER MASCHINE ANGEGBEN, FUER DIE DIE ERSATZTEILLISTE BESTIMMT IST.

VON ZEIT ZU ZEIT WERDEN NEUE ODER GEAENDERTE SEITEN HERAUSGEBEN. GEAENDERTE SEITEN TRAGEN DIE GLEICHE SEITENZAHL WIE DIE ZU ERSETZENDEN. BEI NEUEN SEITEN SIND DIE SEITENZAHLN. ZUSAETLICH MIT BUCHSTABEN VERSEHEN. DIESE SEITEN SIND ENTSPRECHEND EINZUHEFTEN. AUSGABE UND AUSGABEDATUM FUER NEUE UND GEAENDERTE SEITEN TRAGEN EIN NEUES AUSGABEDATUM UND ERHOEHTE AUSGABENUMMER. DIE ENTSPRECHENDE AENDERUNGSMITTEILUNGS - NR. IST AM FUSS DER SEITE ANGEGBEN.

EINGERUECKTE ZEILEN IN DER BESCHREIBUNGSSPALTE BEDEUTEN, DASS DIE HIER AUFGEFUEHRTEN TEILE UNTERGRUPPEN BZW. EINZELTEILE DES VORANGEGANGENEN KOMPLETTEILS SIND.

AUS DER ANZAHLSPALTE IST DIE ERFORDERLICHE STUECKZAHL DER TEILE DIESER BAUGRUPPE ERSICHTLICH. EINE AUSNAHME BILDEN DIE EINGERUECKTEN ZEILEN, HIERBEI BEZIEHT SICH DIE ANZAHL AUF 1 STUECK DES VORANGEGANGENEN KOMPLETTEILS.

FUER GEWISSE TEILE WIE UMBAUSAETZE, EINSTELLBLECHE, USW., IST IN DER ANZAHLSPALTE EIN "X" AUFGEFUEHRT. DIESES X BEDEUTET "NACH BEDARF"

ESTE LIBRO CONSTA DE DOS SECCIONES. LA PRIMERA CONTIENE UN INDICE GRAFICO Y DE GRUPOS, ADEMAS DEL INDICE NUMERICO DE LAS PIEZAS DE RECAMBIO O REFACCIONES INCLUIDAS EN ESTE LIBRO. LOS NUMEROS DE LAS PAGINAS CORRESPONDIENTES A ESTA SECCION TIENEN LOS NUMERALES ROMANOS.

LA SEGUNDA SECCION INCLUYE UNA LISTA DE NUMEROS DE LAS PIEZAS, RELACIONADA CON LOS NUMEROS QUE FIGURAN EN LA ILUSTRACION DE LA PAGINA OPUESTA. LOS NUMEROS DE ORDEN DE LAS PAGINAS DE ESTA SECCION TIENEN LOS NUMERALES ARABICOS O CORRIENTES.

LOS NUMEROS DE ORDEN DE LAS PIEZAS ESTAN EN LA ESQUINA SUPERIOR DE CADA PAGINA. EL NUMERO DE CODIGO DEL LIBRO Y LA FECHA ESTAN EN LA ESQUINA INFERIOR DE CADA PAGINA. TAMBIEN FIGURA EN TODAS LAS PAGINAS EL NOMBRE DE LA MAQUINA PARA FACILITAR SU IDENTIFICACION EN EL LIBRO CORRESPONDIENTE.

CUANDO SURJAN MODIFICACIONES SE INFORMARA POR MEDIO DE LOS "BOLETINES DE PIEZAS DE RECAMBIO". LA INFORMACION DADA EN ESTOS BOLETINES DEBE SER ANOTADA INMEDIATAMENTE EN LAS PAGINAS EN SU LUGAR APROPIADO.

LAS PAGINAS NUEVAS LLEVARAN EL NUMERO DE PAGINA EXISTENTE SEGUIDO POR UN SUFIJO ALFABETICO. DICHAS PAGINAS DEBEN SER INSERTADAS EN EL LIBRO INMEDIATAMENTE, DETRAS DE LA PAGINA EXISTENTE. ESTAS PAGINAS NUEVAS Y REVISADAS LLEVARAN NUMEROS Y FECHAS DE EMISION CONSECUTIVOS Y EL NUMERO DEL CORRESPONDIENTE BOLETIN DE PIEZAS DE RECAMBIO SERA INDICADO AL PIE DE CADA PAGINA.

PARA EVITAR CONFUSIONES Y MANTENER EL LIBRO AL DIA, LAS PAGINAS NUEVAS Y REVISADAS DEBERAN SER INSERTADAS EN SUS CORRESPONDIENTES LIBROS TAN PRONTO LAS RECIBAN.

LAS PIEZAS QUE FIGURAN FUERA DEL MARGEN DE LA LISTA DESCRIPTIVA FORMAN PARTE DEL PRECEDENTE CONJUNTO TOTAL O PARCIAL.

LOS NUMEROS QUE FIGURAN EN LA COLUMNA "CANTIDAD" INDICAN LA CANTIDAD DE PIEZAS USADAS EN LA MAQUINA, EXCEPTO CUANDO LAS PIEZAS FIGURAN RELACIONADAS FUERA DEL MARGEN DE LA LISTA DESCRIPTIVA. EN ESTE CASO EL NUMERO SE REFIERE A LA CANTIDAD REQUERIDA PARA EL PRECEDENTE CONJUNTO TOTAL O PARCIAL.

EN ALGUNOS CASOS, POR EJEMPLO CUANDO SE TRATA DE JUEGOS, SUPLEMENTOS, ETC., EN LA COLUMNA "CANTIDAD" FIGURA UNA 'X'. ESTA 'X' INDICA QUE LA CANTIDAD ES INDETERMINADA, ESTO ES, "TANTO COMO SEA NECESARIO".

**FOREWORD
INTRODUCTION
VORWORT
PREFACIO**

MASSEY-FERGUSON TRACTORS, COMBINES, BALERS AND IMPLEMENTS ARE DESIGNED AND BUILT FOR MAXIMUM PERFORMANCE AND LONG LIFE. ALL SERVICE PARTS ARE MANUFACTURED WITH THE SAME CARE AND PRECISION EXERCISED IN PRODUCTION.

LES TRACTEURS, MOISSONNEUSES BATTEUSES, PRESSES ET INSTRUMENTS MASSEY-FERGUSON SONT CONCUS ET FABRIQUES POUR OBTENIR UN MAXIMUM DE SATISFACTION ET UNE LONGUE DUREE D'UTILISATION. LE MEME SOIN ET LA MEME PRECISION SONT APPORTES A LA FABRICATION DES PIECES DE RECHANGE.

MASSEY-FERGUSON SCHLEPPER, MAEHDRESCHER, BALLENPRESSEN UND GERAETE SIND FUR HOECHSTE BEANSPRUCHUNG UND LANGE LEBENSDAUER GEBAUT. SAEMTLICHE ERSATZTEILE SIND MIT DER GLEICHEN SORGFALT UND GENAUIGKEIT GEFERTIGT.

LOS TRACTORES, COSECHADORAS, ENFARDADORAS Y A PEROS AGRICOLAS MASSEY-FERGUSON, SON DISENADOS Y FABRICADOS PARA LOGRAR LA MAXIMA DURACION Y RENDIMIENTO. TODAS LAS PIEZAS DE RECAMBIO O REFACCIONES SON FABRICADAS CON IDENTICA PRECISION Y CALIDAD DE MATERIAL QUE LAS USADAS EN LA PRODUCCION.

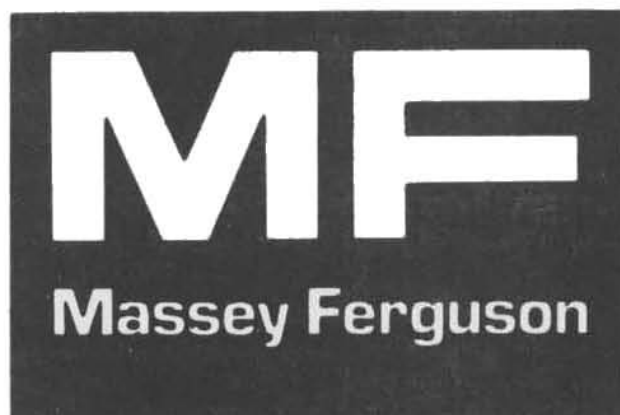

STOCK AND SELL ONLY MASSEY-FERGUSON PARTS
YOUR CUSTOMER EXPECTS IT OF YOU

NE STOCKEZ ET NE VENDEZ QUE LES PIECES MASSEY-FERGUSON
C'EST CE QU' ATTEND DE VOUS VOTRE CLIENT

VERWENDE NUR ORIGINAL MASSEY-FERGUSON TEILE
IHR KUNDE ERWARTET ES VON IHNE#

VENDA UNICAMENTE LAS GENUINAS PIEZAS DE RECAMBIO MASSEY-FERGUSON
SON LAS QUE DESEA Y MERECE SU CLIENTE

PICTORIAL INDEX
TABLE DES MATIERES
BAUGRUPPENVERZEICHNIS
INDICE DE DIBUJOS

CPO.1264/3

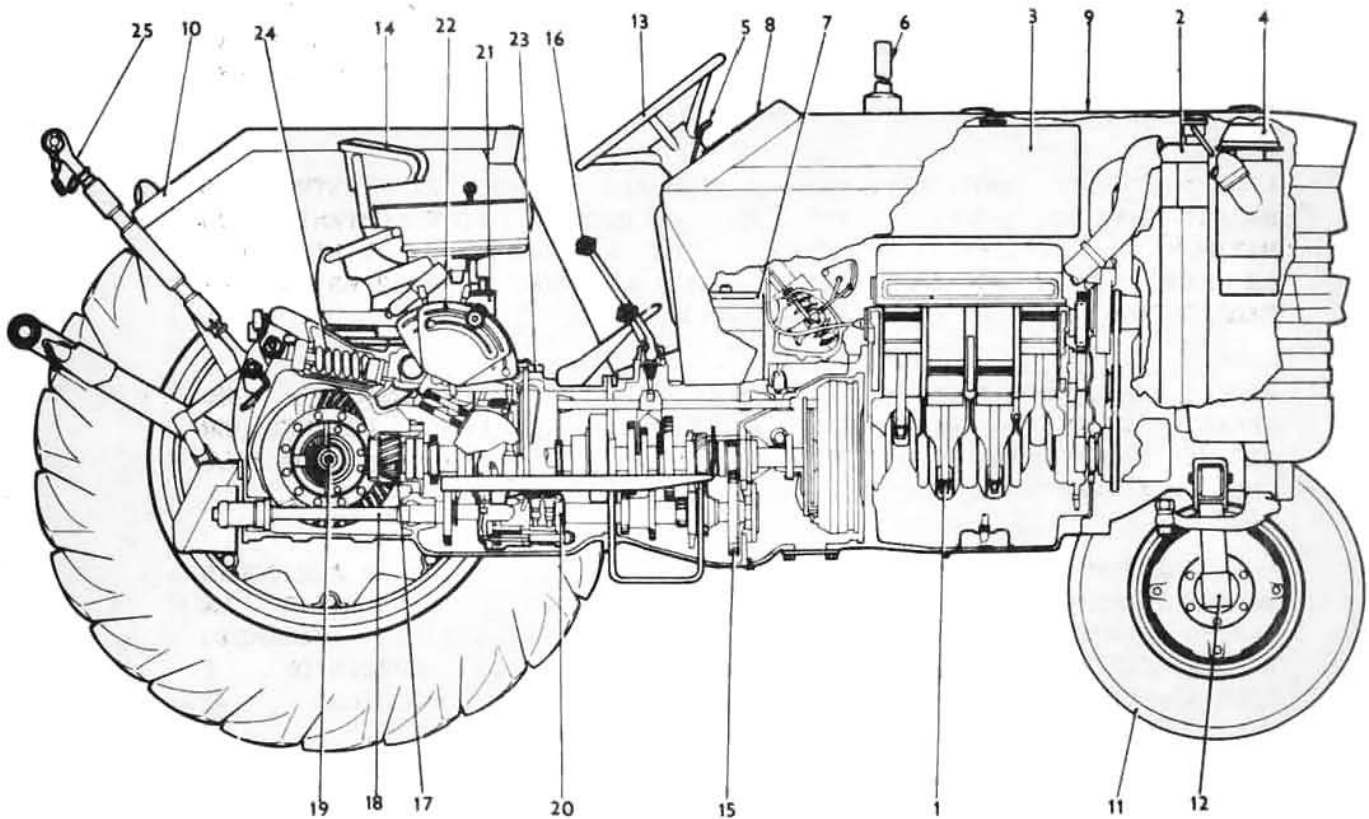

Ref. No.	Description	Designation	Benennung	Descripcion	Pages
1	Engine, AD4.203.....	Moteur, AD4.203.....	Motor, AD4.203.....	Motor, AD4.203.....	2-39
1	Engine, A4.212.....	Moteur, A4.212.....	Motor, A4.212.....	Motor, A4.212.....	40-83
2	Radiator.....	Radiateur.....	Kuehler.....	Radiador.....	97
3	Fuel Tank.....	Reservoir.....	Kraftstoffbehälter.....	Tanque de Combustible.....	98-101
4	Air Cleaners.....	Filtres A Air.....	Luftansaugung.....	Entrada del Aire.....	108-115
5	Throttle Controls.....	Commande des Gaz.....	Motorregelung.....	Controles del Acelerador...	116-119
6	Exhaust.....	Echappement.....	Auspuffanlage.....	Escape.....	120-123
7	Electrical Equipment....	Equipement Electrique....	Elektrische Anlage.....	Equipo Electrico.....	124-127
8	Instruments.....	Instruments.....	Armaturen.....	Instrumentos.....	128-131
9	Sheet Metal.....	Carrosserie.....	Verkleidung.....	Chapa Metalica.....	144-155
10	Fenders.....	Ailes.....	Kotfluegel.....	Guardabarros.....	156-163
11	Wheels.....	Roues.....	Raeder.....	Ruedas.....	166-169
12	Front Axle.....	Essieu Avant.....	Vorderachse.....	Suspension Delantera.....	170-183
13	Steering.....	Direction.....	Lenkung.....	Direccion.....	184-209
14	Seat.....	Siege.....	Fahrersitz.....	Asiento.....	210-221
15	Transmission.....	Boite de Vitesses.....	Getriebe.....	Transmision.....	223-249
16	Gear Shift.....	Commande de la Boite.....	Gangeshalbebel.....	Palanca Selector.....	250
17	Differential Assembly....	Differentiel.....	Differential.....	Diferencial.....	260-271
18	Power Take Off.....	Prise de Force.....	Zapwelle.....	P.T.O.....	272-279
19	Rear Axle Housing.....	Trompettes.....	Hinterachstrichter.....	Caja Trasera.....	280-285
19	Brakes.....	Freins.....	Bremsen.....	Frenos.....	286-299
20	Hydraulic Pump.....	Pompe Hydraulique.....	Hydraulikpumpe.....	Bomba Hidraulica.....	300-309
21	Auxiliary Hydraulics....	Hydraulique Auxiliare....	Hyd. Hilfsmechanismus....	Hidraulica Auxiliar.....	310-353
22	Hydraulic Controls.....	Controles Hydraulique....	Hydraulikschaltung.....	Controles Hidraulica.....	354-363
23	Lift Cover.....	Couvercle Relevage.....	Hydraulikdeckel.....	Tapa de Levante.....	370-373
24	Lift Arms.....	Bras de Relevage.....	Hubwelle.....	Brazos de Levante.....	374-377
25	Hydraulic Linkage.....	Attelage Trois Points....	Draipunktaufhaengung....	Empalmes del Hidraulica...	378-395

<u>Description</u>	<u>Pages</u>
Air Cleaners.....	108-115
Arms, Hydraulic Lift.....	374-377
Auxiliary Hydraulics:-	
Cartridge, Lockout.....	369
Hoses, Single Spool.....	333
Hoses, Two Spool.....	342
Kits, Auxiliary.....	348-353
Kits, Single Spool.....	334-337
Kits, Two Spool.....	344-347
Oil Cooler.....	320-327
Oil Flow.....	252-255
Pipes, Single Spool.....	329
Pipes, Two Spool.....	338
Pump.....	310-319
Valve, Selector.....	366
Valve, Single Spool.....	330
Valve, Switch.....	365
Valve, Two Spool.....	341
Axle, Front, Normal Duty.....	170-175
Axle, Front, Heavy Duty.....	176-181
Axle, Front, Heavy Duty, Kits.....	182
Axle Housing, Centre.....	256-259
Axle Housing, Rear.....	280-285
Battery.....	125
Box, Levelling, Normal Duty, Cat. I.....	378-381
Box, Levelling, Heavy Duty, Cat. I and II.....	382-389
Brakes, Disc.....	286-289
Brakes, Secondary.....	290-293
Brake Pedals and Linkage.....	294
Cab, Tractor.....	398-407
Cladding.....	450-487
Clutch, Dual.....	88-93
Clutch, Split Torque.....	94
Controls, Draft and Position.....	362
Controls, Response.....	354, 361
Controls, Throttle.....	116-119
Coupling Adaptor.....	433
Cover, Hydraulic Lift.....	370-373
Cylinder, Power Steering.....	200-203
Differential with Differential Lock.....	264-267
Differential without Differential Lock.....	260-263
Differential Lock Mechanism.....	268-271
Drawbar and Stays.....	414
Engine Unit AD4.203 and A4.212.....	84-87
Engine, AD4.203:-	
Air Induction System.....	17
Crankshaft.....	10-13
Cylinder Block.....	2-5
Cylinder Head.....	6-9
Cylinder Head Cover.....	14
Dynamo.....	37
Fuel Injection System.....	34
Fuel Lift Pump.....	30
Fuel Lift Pump Kits.....	33
Joints and Gaskets.....	38
Lubricating Oil Filter.....	26
Lubricating Oil System.....	22-25
Timing Gear.....	18-21
Water Pump.....	29
Engine, A4.212:-	
Air Induction System.....	54
Crankshaft.....	46-49
Cylinder Block.....	41
Cylinder Head.....	42-45
Cylinder Head Cover.....	50-53
Dynamo.....	81
Fuel Injection System.....	76-79
Fuel Lift Pump.....	70-73
Fuel Lift Pump Kits.....	74
Joints and Gaskets.....	82
Lubricating Oil Filter.....	62
Lubricating Oil System.....	58-61
Timing Gear.....	57
Water Pump.....	64-69
Electrical Equipment.....	124-127
Exhaust, Horizontal.....	122
Exhaust, Vertical.....	121
Fan.....	84-87

<u>Description</u>	<u>Pages</u>
Fenders, Rear.....	156-159
Fenders, Flat Top.....	160-163
Filters, Fuel.....	102-107
Footsteps.....	165
Frame Mounting.....	430
Frame Safety.....	446-449
Guard, P.T.O. Pulley.....	417
Handbrake.....	296-299
Harness, Main Wiring.....	125
Headlamps.....	133, 152-155
Hitch, Automatic.....	420-425
Hitch, Pressure Control.....	426
Hood.....	144-151
Hoses, Power Steering.....	190
Hub, Front Wheel, Normal Duty.....	170
Hub, Front Wheel, Heavy Duty.....	178
Instruments.....	128-131
I.P.T.O. Clutch, Valve and Brake.....	278
Jack, Tractor.....	429
Kits Conversion, Power Steering.....	204-209
Lighting Equipment.....	132-143
Links, Lower, Normal Duty Cat. I.....	378-381
Links, Lower, Heavy Duty Cat. I and II.....	382-389
Links, Top, Normal Duty Cat. I.....	390
Links, Top, Heavy Duty, Cat. I and II.....	392-395
Linkage, Steering, Manual and Power.....	186-199
Oil Coolers.....	320-327
Oil Flow, Transmission.....	252-255
Oil Pipe Kits.....	434
Panel, Instrument.....	145
Panels, Side.....	152-155
P.T.O. Shifter Mechanism.....	272-277
Pump, Hydraulic, Multipower.....	306-309
Pump, Hydraulic, Standard.....	300-305
Pump, Power Steering.....	192-199
Radiator.....	97
Seat, De Luxe.....	210
Seat Spring Suspension.....	212-221
Selector Mechanism.....	238
Shift Controls Multipower.....	250
Stabiliser Kits.....	436-445
Starter Motor.....	125
Swinging Drawbar.....	410-413
Tank Fuel.....	98-101
Transfers.....	397
Transmission, 8 Speed.....	228-237
Transmission, Multipower.....	240-249
Transmission, Standard.....	222-227
Transmission Case, Multipower.....	240-243
Transmission Case, Standard.....	222
Wheels, Front and Rear.....	166-169
Wheels, Steering.....	185
Wheel Weights.....	409

<u>Designation</u>	<u>Pages</u>
Ailes Arriere.....	156-159
Ailes Arriere - Dessus Plat.....	160-163
Attelage Automatique.....	420-425
Attelage Modulation de Presion.....	426
Barre a Trous.....	414
Barres de Direction - Manuelle et Assiste.....	186-199
Barre Orientable.....	410-413
Bati Porte - Masses et Masses.....	430
Batis de Securite.....	446-449
Batterie.....	125
Blocage de Differentiel.....	268-271
Boite de Vitesses - 8 Vitesses.....	228-237
Boite de Vitesses - Multipower.....	240-249
Boite de Vitesses - Normale.....	222-227
Boitier de Nivellement - Normale Cat. I.....	378-381
Boitier de Nivellement - Renforce Cat. I et II.....	382-389
Bras de Relevage.....	374-377
Cabine.....	450-487
Cabine de Tracteur.....	398-407
Capot.....	144-151
Carrosserie.....	152-155
Carter - Boite de Vitesses - Multipower.....	240-243
Carter - Boite de Vitesses, Normale.....	222
Carter de Pont Arriere.....	256-259
Commande de Frein.....	294
Commande des Gaz.....	116-119
Controle d'effort et de Position.....	362
Couvercle de Relevage.....	370-373
Cric.....	429
Cylindre - Direction Assiste.....	200-203
Delcalcomanie.....	397
Demarreur.....	125
Differential - Avec Blocage de Differentiel.....	264-267
Differential - Sans Blocage de Differentiel.....	260-263
Echappement Vertical.....	121
Ehcappement Horizontal.....	122
Eclairage.....	132-143
Embrayage.....	88-93
Embrayage et Distributeur de Prise de Force.....	278
Equipement Electrique.....	124-127
Essieu Avant - Normal Seulement.....	170-175
Essieu Avant - Renforce Seulement.....	176-181
Essieu Avant - Renforce - Jeux.....	182
Filtre a Air.....	108-115
Filtre a Combustible.....	102-107
Flexible - Direction Assiste.....	190
Freins a Disque.....	286-289
Frein a Main.....	296-299
Frein Secondaire.....	290-293
Garant de Poulie de P.D.F.....	417
Hydraulique Auxiliare:-	
Cartridge - Lockout.....	369
Debit de L'Huile.....	252-255
Distributeur - un Tiroir.....	330
Distributeur - a Deuxtiroir.....	341
Flexible et Raccords - Distributeur un Tiroir.....	333
Flexible et Raccords - Distributeur a Deuxtiroir.....	342
Jeux, Auxiliare.....	348-353
Jeux, Distributeur a Deux Tiroir.....	344-347
Jeux, Distributeur au Tiroir.....	334-337
Pompe.....	310-319
Radiateur d'Huile.....	320-327
Selecteur.....	366
Vanne de Couplage.....	365
Instruments.....	128-131
Jeu de Stabilisateurs.....	436-445
Jeu de Tuyauteries.....	434
Leviers et Pedale d'Embrayage.....	238
Leviers Multipower.....	250
Limiteur de Couple.....	94
Maillon Inferieurs - Normal, Cat. I.....	378-381
Maillon Inferieurs - Renforce, Cat. I et II.....	382-389
Maillon Superieur - Normal, Cat. I.....	390
Maillon Superieur - Renforce, Cat. I et II.....	392-395
Marchepieds.....	165
Masses de Roue Arriere.....	409
Modulation de Pression.....	354-361
Moteur - Ad4.203 et A4.212.....	84-87

<u>Designation</u>	<u>Pages</u>
Moteur AD4.203:-	
Bloc Cylindre.....	2-5
Cache - Culbuteurs.....	14
Culasse.....	6-9
Distribution.....	18-21
Dynamo.....	37
Equipement d'Injection.....	34
Filtre a Huile.....	26
Jeu Complet de Joints.....	38
Pompe a Eau.....	29
Pompe d'Alimentation.....	30
Pompe d'Alimentation - Jeux.....	33
Systeme d'Admission d'Air.....	17
Systeme de Lubrification.....	22-25
Vilebrequin.....	10-13
Moteur A4.212:-	
Bloc Cylindre.....	41
Cache Culbuteurs.....	50-53
Carter d'Huile.....	58-61
Culasse.....	42-45
Distribution.....	57
Dynamo.....	81
Equipement d'Injection.....	76-79
Filtre d'Huile.....	62
Jeu Complet de Joints.....	82
Pompe a Eau.....	64-69
Pompe d'Alimentation.....	70-73
Pompe d'Alimentation - Jeux.....	74
Systeme d'Admission d'Air.....	54
Vilebrequin.....	46-49
Moyeu, Essieu Avant - Normal Seulement.....	170-175
Moyeu, Essieu Avant - Renforce Seulement.....	176-181
Pale.....	84-87
Panneau - Instruments.....	145
Phares.....	133, 152-155
Pompe - Direction Assiste.....	192-199
Pompe Hydraulique - Multipower.....	306-309
Pompe Hydraulique - Standard.....	300-305
Prise de Force.....	272-277
Raccord Auto Obturateur.....	433
Radiateur.....	97
Radiateur d'Huile.....	320-327
Reservoir.....	98-101
Roues Avant et Arriere.....	166-169
Siege - Deluxe.....	210
Siege - Suspendu.....	212-221
Trompettes.....	280-285
Tubulures a Carburant.....	102-107
Volant de Direction.....	185

<u>Benennung</u>	<u>Seite</u>
Abziehbild.....	397
Ackerschleife und Stabilisierungsstreben.....	414
Anlasser.....	125
Armaturen.....	128-131
Armaturenbrett.....	145
Auspuffanlage - Vertical.....	121
Auspuffanlage - Horizontal.....	122
Automatische Hitch.....	420-425
Baldachin.....	450-487
Baldachin Schlepper.....	398-407
Batterie.....	125
Beleuchtung.....	132-143
Bremsen.....	286-289
Bremspedal und Bremsgestaenge.....	294
Differentialgehäuse.....	256-259
Differential mit Differentialsperre.....	264-267
Differential ohne Differentialsperre.....	260-263
Differentialsperre.....	268-271
Druckverstellung.....	354-361
Elektrische Anlage.....	124-127
Fahrersitz - Deluxe.....	210
Fahrersitz - Hydr. Gedaempft.....	212-221
Frontgewichte.....	430
Gehäuse - Getriebe Multipower.....	240-243
Gehäuse - Getriebe Standard.....	222
Getriebe 8 Gang.....	228-237
Getriebe Multipower.....	240-249
Getriebe Standard.....	222-227
Gewicht.....	430
Handbremse.....	296-299
Hebels und Kupplungspedal.....	238
Hebels - Multipower.....	250
Hinterachstrichter.....	280-285
Hinteradgewicht.....	409
Hinterkotfluegel.....	156-163
Hubwelle.....	374-377
Hydraulikdeckel.....	370-373
Hydraulikpumpe - Multipower.....	306-309
Hydraulikpumpe - Standard.....	300-305
Hydraulischer Hilfsmechanismus:-	
Cartridge - Lockout.....	369
Einfachsteuerventil.....	329
Einfachsteuerventil.....	330
Oelkuehler.....	320-327
Pompe.....	310-319
Reparatursatz Einfachsteuerventil.....	334-337
Reparatursatz - Hilfsmechanismus.....	348-353
Reparatursatz - Zwillingsteuerventil.....	344-347
Schaltventil.....	364-367
Schlauch und Kupplungen Einfachsteuerventil.....	333
Schlauch und Zwillingsteuerventil.....	342
Zwillingsteuerventil.....	341
Kuehler.....	97
Kraftstoffbehälter.....	98-101
Kraftstofffilter.....	102-107
Kupplung.....	88-93
Kupplung und Ventil Unabhängige Zapfwelle.....	278
Leitung - Lenkhilfe.....	190
Lenkgestaenge - Hand und Lenkhilfe.....	186-199
Lenkrad.....	185
Luftansaugung.....	108-115
Motor AD4.203 und A4.212.....	84-87
Motor AD4.203:-	
Dichtungsaetze.....	38
Einspritzausfuestung.....	34
Kraftstoffoerdepumpe.....	30
Kraftstoffoerdepumpe - Reparatursatze.....	33
Kurbelwelle.....	10-13
Lichtmaschine.....	37
Luftansauggehäuse.....	17
Oelfilter.....	26
Schmiereinrichtung.....	22-25
Steugetriebe.....	18-21
Wasserpumpe.....	29
Zylinderblock.....	2-5
Zylinderkopf.....	6-9
Zylinderkopfdeckel.....	14

<u>Benennung</u>	<u>Seite</u>
Motor A4.212:-	
Dichtungensätze.....	82
Einspritzausrüstung.....	76-79
Kraftstofförderpumpe.....	70-73
Kraftstofförderpumpe - Reparatursatz.....	74
Kurbelwelle.....	46-49
Lichtmaschine.....	81
Luftansauggehäuse.....	54
Ölfilter.....	62
Schmiereinrichtung.....	58-61
Steuertriebe.....	57
Wasserpumpe.....	64-69
Zylinderblock.....	41
Zylinderkopf.....	42-45
Zylinderkopfdeckel.....	50-53
Motorhaube.....	144-151
Motorregelung.....	116-119
Obere Lenker - Normalausführung, Kat. I.....	390
Obere Lenker - Verstärkte Ausführung, Kat. I und II.....	392-395
Oelleitung Kupplung.....	433
Pumpe - Lenkhilfe.....	192-199
Radnabe - Vorderachse - Normalausführung.....	170
Radnabe - Vorderachse - Verstärkte Ausführung.....	178
Rutschkupplung.....	94
Satz Stabilisierungsketten.....	436-445
Scheinwerfer.....	133, 152-155
Sicherheitskotflügel.....	160-163
Sicherheitsrahmen.....	446-449
Traktor Heber.....	429
Trittbretter.....	165
Unterenker - Normalausführung, Kat. I.....	378-381
Unterenker - Verstärkte Ausführung, Kat. I und II.....	382-389
Verkleidung.....	152-155
Verstellvorrichtung - Normalausführung, Kat. I.....	378-381
Verstellvorrichtung - Verstärkte Ausführung, Kat. I und II.....	382-389
Vorder und Hinterräder.....	166-169
Vorderachse - Normalausführung.....	170-175
Vorderachse - Verstärkte Ausführung.....	176-181
Vorderachse - Reparatursatz.....	182
Vorfilter.....	113
Windflügel.....	84-87
Zapfwellenshaltung.....	272-277
Zapfwellenschutz.....	417
Zugkraft und Positionseinstellung.....	362
Zugkraftverstärker Hitch.....	426
Zuggendel.....	410-413
Zweite Bremse.....	290-293
Zylinder - Lenkhilfe.....	200-203

<u>Descripcion</u>	<u>Paginas</u>
Adaptador de Union de Tubos.....	433
Asiento - Con Suspencion.....	212-221
Asiento - De Lujo.....	210
Barra Tiro Oscilante.....	410-413
Barra de Tiro y Tirentes.....	414
Barras de Direccion - Mecanica y Hidraulica.....	186-199
Barras del Enganche Inferiores - Servicio Normal Cat. I.....	378-381
Barras del Enganche Inferiores - Servicio Pesado Cat. I y II.....	382-389
Barras del Enganche Superior - Servicio Pesado Cat. I.....	390
Barras del Enganche Superior - Servicio Pesado Cat I y II.....	392-395
Bastidores de Defensa.....	446-449
Bastidor y Pesas.....	430
Bateria.....	125
Bomba - Direccion Hidraulica.....	192-199
Bomba Hidraulica - Multipower.....	306-309
Bomba Hidraulica - Standard.....	300-305
Braños de Levante.....	374-377
Cabina.....	450-487
Cabina de Tractor.....	398-407
Caja Central.....	256-259
Caja Niveladora - Servicio Normal Cat. I.....	378-381
Caja Niveladora - Servicio Pesado Cat. I y II.....	382-389
Caja Transmission - Multipower.....	240-243
Caja Transmission - Standard.....	222
Caja Trasera.....	280-285
Calcomania.....	397
Capo.....	144-151
Cilindro - Direccion Hidraulica.....	200-203
Controles del Acelerador.....	116-119
Controles del Tiro y de Posicion.....	362
Controles de Presion.....	354-361
Cricco Solteramento.....	429
Cubo Suspencion Delantera - Servicio Normal.....	397
Cubo Suspencion Delantera - Servicio Pesado.....	178
Defensa de la Polea del P.T.O.....	417
Diferencial - Con Blocaador del Diferencial.....	264-267
Diferencial - Sin Blocaador del Diferencial.....	260-263
Embrague.....	88-93
Embrague de Torque Dividido.....	94
Enfriador del Aceite.....	320-327
Enganche Automatico.....	420-425
Enganche del Control de Presion.....	426
Entrada del Aire.....	108-115
Equipo Electrico.....	124-127
Equipo de Faros.....	132-143
Escape Vertical.....	121
Escape Horizontal.....	122
Estribos.....	165
Faros.....	133,152-155
Filtro Centrifugo del Aire.....	113
Filtro de Combustible.....	102-107
Freno de Mano.....	296-299
Freno de Disco.....	286-289
Freno Secundario.....	290-293
Guardabarros Traseros.....	156-159
Guardabarros Traseros - Tipo Plano.....	160-163
Hidraulica Auxiliar:-	
Bomba.....	310-319
Cartridge Lockout.....	369
Enfriador del Aceite.....	320-327
Juegos - Auxiliar.....	348-353
Juegos - Valvula de un Carrete.....	344-347
Juegos Valvula de un Carrete.....	334-337
Manguera y Uniones - Valvula de un Carrete.....	333
Manguera y Uniones - Valvula de cos Carretes.....	342
Valvula de un Carrete.....	330
Valvula de cos Carretes.....	341
Valvula Comutador.....	365
Valvula Selector.....	366
Instrumentos.....	128-131
Juego Estabilizadores.....	436-445
Juego Tubos del Aceite.....	434
Manguera - Direccion Hidraulica.....	190
M. Arranque.....	125
Mecanismo del Blocaador del Diferencial.....	268-271
Mecanismo del Cambio del P.T.O.....	272-277
Motor AD4.203:-	
Bloque de Cilindros.....	2-5

<u>Descripcion</u>	<u>Paginas</u>
Motor AD4.203:- (Continuacion)	
Bomba de Agua.....	29
Bomba de Aspiracion de Combustible.....	30
Bomba de Aspiracion de Combustible - Juegos.....	33
Ciguenal.....	10-13
Culata.....	6-9
Distribucion.....	18-21
Dynamo.....	37
Equipo de Inyeccion de Combustible.....	34
Filtro de Aceite Lubricante.....	26
Juego de Juntas.....	38
Systema de Aceite Lubricante.....	22-25
Systema de Induccion de Aire.....	17
Tapa de Culata.....	14
Motor A4.212:-	
Bloque de Cilindros.....	41
Bomba de Agua.....	64-69
Bomba de Aspiracion de Combustible.....	70-73
Bomba de Aspiracion de Combustible - Juegos.....	74
Carter del Motor.....	58-61
Ciguenal.....	46-49
Culata.....	42-45
Distribucion.....	57
Dynamo.....	81
Equipo de Inyeccion de Combustible.....	76-79
Filtro de Aceite Lubricante.....	62
Juego de Juntas.....	82
Systema de Induccion de Aire.....	54
Tapa de Culata.....	50-53
Motor - Piezas de Montaje Final, AD4.203 y A4.212.....	84-87
Palancas y Pedal de Embrague.....	238
Palancas - Multipower.....	250
Panales.....	152-155
Panel - Instrumentos.....	145
Pedales del Freno y Varillaje.....	294
Pesas de Ruedas Traseras.....	409
Radiador.....	97
Ruedas Delanteras y Traseras.....	166-169
Suspension Delantera - Servicio Normal.....	170-175
Suspension Delantera - Servicio Pesado.....	176-181
Suspension Delantera - Juegos.....	182
Tanque del Combustible.....	98-101
Tapa de Levante.....	370-373
Transmission 8 Velocidades.....	228-237
Transmission - Multipower.....	240-249
Transmission - Standard.....	222-227
Tuberial del Combustible.....	102-107
Ventilador.....	84-87
Volante de la Direccion.....	185

NUMERICAL INDEX - MF NUMBERS
 INDEX NUMERIQUE - MF NUMEROS
 NUMERN - INDEX - MF NUMBERS
 INDICE NUMERICO - MF NUMEROS

Part No.	See Page	Part No.	See Page	Part No.	See Page	Part No.	See Page
MP 1056	170,177	180 457 M1	222,241	181 327 M1	Use 883 766 M91	184 326 M91	Use 886 845 M91
GA 1773	417	180 458 M1	225,237,245	181 328 M1	170	184 334 M1	286
GK 2151	234,245	180 461 M1	273	181 345 M1	381,385,386	184 355 M91	390,393
2 760 X	Use 353 441 X1	180 462 M1	225	181 363 M1	Use 888 457 M1	184 356 M1	281
2 950 X	222,229,241,269	180 465 M1	273	181 408 M1	257	184 357 M1	378,381
2 957 X	193,194,197,309,362	180 474 M1	222,229,233,241,257,281	181 958 M1	294	184 361 M91	390
2 971 X	358	180 481 M1	222,241	181 964 M1	294	184 362 M91	390,393
12 501 X	Use 29 780 X	180 482 M1	222,229,233,241	181 982 M1	370	184 365 M2	273
13 222 X	238	180 485 M1	414	181 993 M91	301	184 368 M1	378,381
13 535 X	278	180 511 M2	229,238	181 999 M1	301,302	184 369 M1	Use 884 436 M1
13 710 X	426	180 579 M3	238	182 274 M2	Use 1860 403 M1	184 377 M1	378,381
14 462 X	286,293	180 581 M1	238	182 457 M91	157	184 382 M91	Use 1885 318 M91
15 221 X	93,94	180 582 M1	238	182 501 M1	170	184 441 M1	281
15 360 X	362	180 583 M1	238	182 534 M91	Use 884 701 M91	184 461 M92	378,414
16 710 X	213	180 673 M1	145	182 581 M1	370	184 462 M92	378,414
16 773 X	354	180 798 M1	261,265	182 582 M1	370	184 463 M92	378
16 779 X	286,289	180 801 M1	222,229,233,241	182 725 M1	186,205,206,209	184 464 M92	378
18 543 X	234	180 809 M1	294	182 977 M1	437,441	184 549 M92	390
19 467 X	417	180 864 M1	294	183 021 M2	170,177	184 551 M1	390,393
19 752 X	89,93,94	180 870 M1	165,294	183 037 M1	225,237,245	184 552 M91	390
19 921 X	157	180 901 M91	257	183 038 M1	237,245	184 553 M91	390,393
22 042 X	306,314	180 904 M2	257,302	183 040 M1	225,237,245	184 555 M1	390,393
22 199 X	322,330,341	180 908 M1	370	183 054 M91	225	184 568 M91	437
22 208 X	306,314	180 916 M1	374	183 080 M1	190,201,205,206,209	184 569 M1	437
22 257 X	278	180 917 M1	374	183 086 M1	170,177	184 570 M1	437
22 370 X	321,374	180 924 M1	301	183 088 M2	229	184 571 M1	437
22 427 X	213,250	180 925 M1	301	183 129 M2	89,94	184 572 M91	437,441
22 428 X	125	180 926 M1	301	183 254 M1	261,265	184 580 M1	238
22 445 X	138,450,453,458,461,462	180 927 M2	301,302	183 462 M1	286	184 582 M2	265
22 463 X	125,450,453,458,461,462	180 928 M1	301,302	183 515 M92	286	184 588 M2	286
22 464 X	301	180 929 M1	301,302	183 600 M1	417	184 592 M1	222,233,238,241
22 764 X	213,318,377	180 930 M1	301,302	183 611 M92	Use 1861 288 M91/ with 810 285 M91	184 624 M2	261
22 830 X	278	180 933 M1	301	183 614 M2	390,393	184 683 M1	269
29 780 X	294	180 940 M1	301	183 615 M93	390,393,414	184 684 M1	269
29 958 X	170,173,177,178,186,205,206,209,294	180 941 M1	301	183 618 M91	382	184 685 M1	269
52 964 M1	438,442,445	180 947 M1	301	183 619 M92	390,393	184 688 M2	269
67 285 M1	333,334,342,345	180 948 M1	301	183 621 M1	382	184 742 M1	281,285
180 004 M1	166	180 972 M2	370	183 623 M93	393	184 770 M1	225,234,245
180 010 M1	170	180 973 M2	370	183 630 M1	382,386	184 789 M1	222,229,233,241
180 313 M1	273	180 974 M1	370	183 634 M1	385	185 365 M1	414
180 408 M2	225,234,245	180 979 M1	370	183 734 M1	Use 376 393 X1	185 425 M1	245
180 409 M1	225,234,245	180 980 M1	Use 887 654 M1	183 735 M1	Use 884 389 M1	185 464 M1	245
180 415 M1	225,234,245	180 981 M1	370	183 838 M1	301	185 509 M92	414
180 418 M1	222,229,233,241,274,277	180 982 M1	370	183 844 M1	354	185 511 M1	414
180 419 M1	225,234,245	180 990 M1	374	183 958 M1	129	185 511 M93	301
180 428 M2	225	181 041 M1	362	184 011 M1	225,234,245	185 555 M1	301
180 432 M1	225,234,246	181 103 M1	89	184 012 M3	225,234,245	185 579 M91	414
180 434 M1	225,245	181 118 M1	89	184 078 M91	390	185 688 M1	253
180 437 M1	222,241	181 124 M1	89,93	184 079 M91	390	185 800 M1	269
180 438 M2	222,233,241	181 149 M1	294	184 160 M1	225	185 802 M4	269
180 442 M2	222,233,241	181 204 M92	273	184 161 M1	225	185 839 M91	301
180 444 M1	222,229,233,241	181 211 M91	274	184 162 M1	225	185 879 M91	333,342
180 445 M1	225,237,245	181 214 M1	274	184 163 M1	225	186 198 M1	245
180 446 M1	222,229,233,241	181 217 M1	257,274,277	184 170 M1	225	186 218 M91	333,342,433
180 449 M1	222,229,233,241	181 224 M1	261,265	184 171 M1	286,289	186 506 M1	269
180 451 M2	89,93,94	181 237 M1	225,246	184 174 M91	Use 884 066 M91	186 518 M1	253
180 453 M1	222,241	181 246 M1	261,265	184 182 M3	281,285	186 519 M1	245
180 455 M1	261,265	181 247 M1	261,265	184 184 M1	261,265	186 527 M1	253
180 456 M1	261,265	181 253 M1	261,265	184 190 M1	273	186 531 M2	245
		181 275 M1	261,265	184 191 M1	261,265	186 532 M1	Use 510 241 M1
		181 276 M1	261,265	184 192 M1	261,265	186 537 M1	245
		181 277 M1	261,265	184 193 M1	273	186 542 M1	245
		181 320 M1	210,217	184 194 M1	257	186 567 M1	245
		181 321 M1	210,217	184 196 M1	281,285	186 568 M1	253
		181 322 M1	210	184 225 M91	Use 1884 762 M91	186 570 M1	253
		181 323 M1	210	184 257 M1	286	186 579 M1	245
		181 325 M91	210,217	184 310 M1	286,289	186 580 M1	245
				184 311 M1	269	186 581 M1	245
						186 802 M1	378

NUMERICAL INDEX - MF NUMBERS
 INDEX NUMERIQUE - MF NUMEROS
 NUMMERN - INDEX - MF NUMMERS
 INDICE NUMERICO - MF NUMEROS

Part No.	See Page	Part No.	See Page	Part No.	See Page	Part No.	See Page
186 808 M2	253	191 833 M1	321	195 453 M1	225, 234, 246, 273	339 053 X1	221
186 809 M1	378	191 855 M4	321			339 054 X1	221
186 812 M1	253	192 329 M1	Use 882 296 M1	195 457 M1	378	339 106 X1	473
186 946 M91	378, 414, 441	192 431 M1	274	195 468 M1	274, 277	339 123 X1	478, 485
187 074 M1	245	192 778 M1	269	195 490 M1	170, 178	339 124 X1	469, 470, 473, 474, 478, 481, 485
187 082 M1	309	192 779 M1	269	195 493 M1	225, 234, 245		
187 084 M1	309, 310, 313	192 799 M1	213	195 494 M1	225	339 169 X1	221
187 093 M1	309	192 805 M91	213, 214	195 494 M1	225	339 287 X1	473
187 137 M1	145, 250, 397	192 806 M1	213	195 496 M1	277	339 560 X1	469, 474, 477, 478, 481, 482, 485
187 142 M91	253	192 807 M91	213	195 498 M1	273		
187 143 M1	253	192 812 M1	213	195 499 M1	225, 234	339 577 X1	474, 481
187 193 M91	414	192 813 M1	213	195 500 M1	225, 234, 246	339 666 X1	469
187 271 M1	122	192 814 M1	213	195 501 M1	225	339 722 X1	470
187 689 M1	265	192 815 M1	213	195 503 M1	225	339 736 X1	Use 884 334 M91
188 148 M1	378	192 816 M91	213	195 505 M1	225	339 763 X1	221
188 359 M1	378	192 824 M91	213	195 506 M1	Use 1860 325 M1	339 804 X1	477, 482
188 803 M1	246	192 828 M1	213	195 507 M1	225, 234, 246	343 968 X1	434
188 805 M2	253, 306, 309	192 829 M91	213	195 513 M1	229, 233, 241	345 718 X1	293, 297
188 807 M2	253	192 847 M1	213	195 522 M1	273	346 160 X1	469, 477, 482
188 809 M1	309	192 856 M1	213	195 527 M1	417	345 162 X1	422
188 810 M1	309	192 950 M1	213	195 546 M1	213	347 341 X1	285
188 811 M91	309	193 006 M1	Use 888 607 M1	195 559 M1	Use 893 741 M1	350 355 X1	170, 177
188 830 M91	246	193 092 M1	381, 385, 386	195 561 M1	354, 362, 366, 370	352 438 X1	238, 386
188 834 M2	246	193 181 M1	378			352 972 X1	245
188 838 M91	246	193 373 M1	213	195 562 M1	274, 277, 374	352 980 X1	269, 297, 301
188 840 M1	246	193 446 M91	NLS Use Details	195 567 M1	301, 370	353 120 X1	370
188 841 M1	245	194 234 M1	146	195 569 M1	257	353 213 X1	306, 317, 318
188 843 M2	245	194 235 M1	146	195 573 M1	370	353 254 X1	270
188 844 M91	245	194 252 M1	146	195 575 M1	374	353 426 X1	86, 125, 165, 210, 213, 214, 217, 221, 222, 229, 233, 241, 269, 281, 285, 294, 414
188 847 M92	Use 884 794 M91	194 433 M1	310, 313	195 576 M1	321, 358		
188 852 M1	246	194 435 M1	310, 313	195 581 M1	301	353 427 X1	157, 161, 162, 166, 170, 173, 177, 186, 410, 413, 422, 429, 438, 446
188 855 M1	309	194 444 M2	310, 313	195 589 M1	390, 393		
188 859 M1	246	194 447 M93	310, 313	195 593 M1	370	353 428 X1	126, 185, 270
188 880 M2	253	194 449 M2	310, 313	195 610 M1	117	353 429 X1	378, 381
188 908 M92	253, 306, 309	194 450 M91	314	195 644 M1	378, 382, 386	353 430 X1	89, 93, 94, 126, 190, 205, 206, 209, 238, 286, 294, 297
188 909 M1	190, 205	194 454 M92	310	195 648 M1	381, 385, 386		
189 150 M91	309	194 485 M91	253	195 682 M1	417	353 431 X1	102, 129, 142, 157, 165, 189, 213, 214, 217, 218, 221, 269, 326, 329, 330, 334, 338, 341, 345, 346, 426
189 169 M1	354	194 559 M1	362	195 690 M1	261, 265		
189 318 M1	Use 506 667 M1	194 560 M1	362	195 694 M1	97	353 432 X1	97, 125, 145, 146, 165, 185, 210, 213, 214, 217, 221, 257, 269, 281, 285, 286, 293, 294, 365, 366, 370, 390, 393, 417
189 366 M1	301	194 571 M93	174	195 873 M1	245		
189 373 M1	301	194 572 M93	174	195 874 M1	366, 370		
189 391 M91	246	194 742 M1	121, 122	195 904 M1	294	353 433 X1	154, 157, 161, 162, 170, 173, 177, 178, 186, 409, 410, 413, 422, 429, 430, 438, 442, 446
189 396 M91	245	194 962 M94	241	195 910 M1	294		
189 439 M1	234	194 963 M94	241	195 914 M1	109		
189 449 M1	225, 237, 245	195 222 M1	225	195 946 M1	Use 352 980 X1		
189 604 M1	98, 101	195 242 M1	294	195 949 M1	301		
189 605 M2	98, 101	195 251 M1	417	196 059 M1	186		
189 606 M1	193	195 258 M1	213	196 079 M1	186		
190 177 M1	Use 1862 289 M1	195 270 M1	238, 294, 297	196 097 M1	261, 265		
190 342 M1	365	195 284 M1	273	196 108 M1	358		
190 346 M1	365	195 339 M1	437	196 162 M1	422		
190 375 M1	365	195 340 M1	390	196 167 M1	170, 177		
190 376 M1	365	195 344 M1	441	196 174 M1	330, 341, 369		
190 560 M1	186	195 346 M1	Use 888 086 M1	196 199 M1	397		
190 845 M91	253, 306, 309	195 347 M1	257, 378, 382, 386, 390, 393, 410, 413, 414, 421, 430, 437, 441	196 210 M1	397		
190 847 M91	309			200 191 M1	170, 177, 178, 378, 381, 382, 385, 386, 422, 426		
190 873 M1	250	195 348 M1	289	254 523 X1	205		
190 874 M1	250	195 357 M1	410	322 823 M1	213, 214		
190 976 M1	297	195 363 M1	225, 234, 245	327 180 M91	430		
191 142 M1	Use 1884 289 M1	195 390 M1	321	330 253 X1	229		
191 221 M1	222, 229, 233, 241, 274, 277	195 396 M1	378, 381	353 446 X1	306		
191 250 M1	261, 265	195 397 M1	382	338 548 X1	126		
191 491 M1	238	195 405 M1	382, 386	338 552 X1	234		
191 495 M1	178	195 415 M1	378, 381, 382, 386, 422	338 553 X1	238		
191 827 M92	321			339 011 X1	481		
191 830 M1	321	195 441 M1	126, 138	339 030 X1	478, 485		
191 831 M1	321						
191 832 M1	321						

NUMERICAL INDEX - MF NUMBERS
 INDEX NUMERIQUE - MF NUMEROS
 NUMERN - INDEX - MF NUMBERS
 INDICE NUMERICO - MF NUMEROS

Part No.	See Page	Part No.	See Page	Part No.	See Page	Part No.	See Page
353 434 XI	129,142,157, 165,186,189, 190,194,197, 205,206,217, 218,221,222, 225,229,233, 234,241,245, 289,306,314, 322,326,329, 334,338,345, 346,362,398, 426	353 503 XI	481	353 639 XI	225	353 755 XI	98,101,113, 117,133,145, 157,161,162, 165,190,206, 309,417,469, 470,473,474, 478,481,485
353 435 XI	170,382,386, 410,437,442, 445	353 504 XI	142	353 643 XI	446	353 756 XI	117,129,142, 165,213,217, 221,297,329, 334,338,345, 346,354,362,378
353 436 XI	186,205,206, 209,281,382, 386,417,441	353 505 XI	153	353 652 XI	186	353 757 XI	117,121,122, 213,261,265, 366,390,393, 434
353 437 XI	186,218,238, 257,409,422, 446	353 507 XI	117,250	353 659 XI	157,161,162	353 758 XI	402
353 438 XI	370,410	353 510 XI	333,334,342, 345	353 664 XI	154	353 760 XI	446
353 439 XI	138,161,186, 190,238,257, 402,409,422, 446	353 515 XI	97,102	353 665 XI	145,450,453, 458,461,462	353 762 XI	378,382,417
353 440 XI	281,290,382, 410,421,437, 441,442,445	353 516 XI	85,86,109,110, 113,133,145, 190,205,218, 322,326	353 666 XI	125,250,377, 453,461,462	353 771 XI	157,213,214, 225,234,246
353 441 XI	97,101,113, 114,117,125, 129,137,138, 142,145,146, 153,154,157, 161,162,165, 190,201,205, 221,250,274, 277,322,326, 329,330,334, 338,341,342, 346,362,377, 426,450,453, 458,461,462	353 517 XI	97,125,190, 206,209,309, 321	353 667 XI	146,398,402, 450,458,462	353 772 XI	210,213,214, 217,221,414
353 444 XI	213,214,354	353 518 XI	190,202	353 668 XI	377	353 773 XI	422,446
353 445 XI	105,125,133, 134,138,145, 153,397,462	353 520 XI	146	353 676 XI	321	353 774 XI	157,166,446
353 446 XI	97,98,101,102, 109,110,113, 114,121,122, 133,142,145, 165,190,202, 205,206,209, 210,218,301, 309,310,313, 321,322,326	353 521 XI	321	353 678 XI	121,122,142	353 775 XI	177,281
353 460 XI	185,426	353 522 XI	122	353 680 XI	229	353 776 XI	165
353 473 XI	117	353 525 XI	98	353 683 XI	309	353 788 XI	117
353 486 XI	410	353 528 XI	206,209	353 687 XI	309	353 807 XI	157,210,217
353 500 XI	97	353 529 XI	98,206	353 688 XI	377	353 809 XI	157,165
353 501 XI	97,129,145, 146,153,154, 161,190,202, 205,326,426	353 530 XI	377	353 690 XI	222,225,229, 233,241,246, 377	353 810 XI	165
353 502 XI	117,125,138, 145,146,153, 201,221,342	353 536 XI	105	353 693 XI	234,398	353 811 XI	165
353 503 XI	274,277,322, 326,470,474,	353 537 XI	105,157,213, 214	353 694 XI	269	353 863 XI	214
		353 538 XI	102,105,126, 213,322,326	353 696 XI	145,274,277	353 875 XI	422
		353 539 XI	105,129,157	353 697 XI	97,269,281, 293	353 894 XI	446
		353 540 XI	125,142,165, 334,345,346	353 698 XI	86,238,286, 354	353 897 XI	241,398
		353 541 XI	126,142,426	353 699 XI	269,274,277, 417	353 901 XI	222,229,233, 430
		353 542 XI	142,329,334, 338,345,346	353 700 XI	165	353 916 XI	98,109,114, 122,125,146, 165,218,257
		353 543 XI	213	353 701 XI	85,257,261, 265,370	353 917 XI	89,93,365,377
		353 544 XI	189,329,334, 338,345	353 702 XI	185	353 918 XI	101,117,125, 137,138,142, 146,157,161, 162,250,321, 322,326,362
		353 546 XI	125,209,314, 334,345	353 704 XI	86	353 919 XI	113,117,165, 274,277,333, 334,342,345, 362
		353 548 XI	217	353 706 XI	86,238	353 925 XI	417
		353 552 XI	346	353 707 XI	85	353 928 XI	170,378,382, 417
		353 557 XI	146	353 708 XI	86	353 937 XI	170,177
		353 558 XI	374,417,434	353 710 XI	86	353 957 XI	378
		353 559 XI	374	353 712 XI	125	353 963 XI	241
		353 560 XI	210	353 713 XI	238,365,366	353 971 XI	114
		353 562 XI	217,390,393	353 714 XI	85	353 985 XI	213
		353 563 XI	86,222,229, 233,241,414, 417	353 717 XI	293	353 995 XI	210
		353 564 XI	233,286,293	353 723 XI	138,161,213	354 023 XI	450,458
		353 565 XI	121	353 725 XI	190,257,402	354 039 XI	117,190,201, 205,206,209, 297,301,362, 374
		353 568 XI	269	353 726 XI	446	354 041 XI	202,253
		353 571 XI	294	353 727 XI	446	354 046 XI	89,421,422
		353 572 XI	165	353 729 XI	446	354 048 XI	89,117,417
		353 573 XI	333,342	353 752 XI	450,458	354 055 XI	294
		353 575 XI	334,345	353 753 XI	117,125,138, 145,153,190, 205,206,209, 213,398,401, 402,406,450, 458,462	354 057 XI	286
		353 576 XI	125	353 754 XI	113,114,117, 125,138,142, 145,146,153, 157,161,162, 165,213,250, 253,297,321, 322,326,362, 398,401,402, 405,450,453, 458,461,462, 469,473		
		353 582 XI	281,285				
		353 600 XI	186				
		353 609 XI	438,442				
		353 611 XI	157				
		353 613 XI	446				
		353 615 XI	409,446				
		353 616 XI	145				
		353 618 XI	413				
		353 619 XI	446				
		353 622 XI	186				
		353 623 XI	410				
		353 625 XI	170,177,413				
		353 626 XI	186				

NUMERICAL INDEX - MF NUMBERS
 INDEX NUMERIQUE - MF NUMEROS
 NUMMERN - INDEX - MF NUMMERS
 INDICE NUMERICO - MF NUMEROS

Part No.	See Page	Part No.	See Page	Part No.	See Page	Part No.	See Page
354 059 X1	238, 289, 293, 294, 297, 402	355 124 X1	133, 134, 153	358 838 X91	309, 333, 342	364 564 X1	330, 341
354 066 X1	286, 378, 381, 382, 386, 422	355 126 X1	105	358 848 X91	345	364 565 X1	330, 341
354 068 X1	170, 289, 378, 382, 385, 386, 417	355 128 X1	286	358 876 X1	278	364 587 X1	310
354 070 X1	178	355 129 X1	138	358 890 X1	234, 245	364 590 X1	310, 313
354 072 X1	178, 182, 309, 310, 313	355 286 X1	370	358 913 X1	225, 234, 246	364 689 X1	245, 278
354 074 X1	333, 342, 430	355 335 X1	185	358 950 X1	270	365 603 X1	273
354 076 X1	222, 229, 233, 241, 378, 414, 441	355 564 X1	114, 362, 450, 453, 458, 461, 462	359 001 X1	301, 334, 345, 365	365 986 X1	318
354 078 X1	390, 393, 410	355 565 X1	98, 101, 122, 142, 210	359 002 X1	301, 313, 318, 365	366 005 X91	314
354 087 X1	422	355 566 X1	186, 306, 314	359 020 X1	213	366 045 X1	306, 314, 318
354 089 X1	422, 437, 438, 442, 445	355 582 X1	125	359 136 X1	374	366 105 X1	314
354 091 X1	413, 422	355 584 X1	210, 217	359 140 X1	330, 341	366 465 X1	318
354 101 X1	285	355 615 X1	138	359 242 X1	Use 1850 132 M1	375 090 X1	190, 205, 206, 209
354 118 X1	126, 138	355 617 X1	146, 398, 474, 477, 478, 481, 482, 485	359 250 X1	310, 313, 314, 318, 329, 330, 338, 341	375 099 X1	438, 442, 445
354 119 X1	213, 214	355 619 X1	398	359 288 X1	365	375 107 X1	117
354 120 X1	125, 133, 134, 138, 145, 213, 374, 450, 458, 462	355 696 X1	426	359 291 X1	370	375 108 X1	117, 190, 205, 206, 209
354 128 X1	293	355 710 X1	422	359 294 X1	358, 365	375 109 X1	170, 177, 186
354 186 X1	374	355 723 X1	269, 270	359 295 X1	313, 318	375 111 X1	170, 177
354 198 X1	125, 138, 145	355 781 X1	301	359 297 X1	333, 342	375 182 X1	281, 285
354 203 X1	354	355 791 X1	193, 194, 197	359 404 X1	125	375 184 X1	358, 370
354 230 X1	429	355 863 X1	213	359 409 X1	138	375 231 X1	421
354 239 X1	210	355 917 X1	186	359 444 X1	330, 341	375 285 X1	410, 413
354 244 X1	165	355 976 X1	382, 386	359 492 X1	97	375 285 X1	410, 413
354 245 X1	Use 353 788 X1	355 988 X1	225, 234, 246	359 530 X1	354	375 372 X1	417
354 262 X1	229, 233, 398	356 266 X1	321	360 039 X1	97	375 373 X1	145, 153
354 264 X1	186, 190, 206, 209	356 302 X1	354	360 222 X1	426	375 382 X1	321, 322, 326
354 265 X1	234	356 353 X1	321	360 228 X1	422	375 415 X1	261
354 267 X1	289	356 392 X1	358	360 288 X1	301	375 706 X1	121, 122
354 271 X1	225, 234, 245, 289	356 579 X1	329, 338, 349	360 369 X1	213	375 718 X1	122
354 273 X1	362, 398	356 580 X1	349, 366	360 725 X1	109, 110, 113	375 742 X1	122
354 281 X1	430	356 627 X1	349, 350	360 834 X1	313, 314	375 794 X1	102, 105
354 285 X1	409	356 939 X1	385	360 854 X1	329, 334, 338, 345	376 101 X1	102, 105
354 286 X1	430	357 135 X1	333, 342	361 025 X1	202	376 267 X1	186
354 289 X1	22	357 195 X1	253, 306, 309	361 158 X1	365	376 310 X1	306
354 294 X1	170, 177	357 197 X1	193, 194, 197, 322	361 160 X1	370	376 330 X1	398, 401, 402
354 362 X1	309	357 322 X1	446	361 163 X1	358	376 332 X1	398
354 378 X1	365	357 433 X1	213, 214	361 203 X1	294	376 393 X1	362
354 405 X1	417	357 439 X1	354	361 262 X1	213	376 395 X1	286
354 415 X1	301	357 443 X1	369	361 298 X1	302	376 398 X1	286
354 416 X1	222, 229, 233, 241	357 459 X1	330	361 446 X1	209	376 399 M1	378
354 431 X1	157	357 461 X1	329, 334, 338, 346	361 448 X1	209	376 401 X1	238
354 441 X1	154	357 515 X1	117, 145, 153, 397	362 349 X1	301	376 407 X1	265
354 454 X1	270	357 617 X1	330, 341	362 361 X1	301	376 408 X1	273, 354
354 461 X1	385	357 618 X1	213	362 405 X1	301	376 432 X1	190, 205, 206
354 465 X1	201	357 655 X1	354	362 433 X1	241, 245	376 435 X1	286, 289
354 472 X1	309	357 783 X1	422	362 437 X1	Use 353 692 X1	376 447 X1	294, 446
354 544 X1	238	357 819 X1	253	362 449 X1	245	376 448 X1	121, 122, 213
354 607 X1	462	357 822 X1	253	362 487 X1	286	376 449 X1	Use 884 737 M1
354 650 X1	413	357 852 X1	306, 314, 318	362 551 X1	241	376 451 X1	281, 413
354 689 X1	170, 177	358 380 X1	Use 376 408 X1	362 732 X1	286	376 452 X1	253
354 691 X1	177	358 723 X1	341	363 459 X1	289	376 453 X1	417
354 710 X1	Use 883 448 M1	358 724 X91	334, 337, 345, 366	363 512 X1	269	376 454 X1	197
354 754 X1	321	358 728 X91	350	363 517 X1	213	376 459 X1	370
354 944 X1	310, 313	358 743 X91	334, 345, 349, 350	363 518 X1	213	376 460 X1	370
355 101 X1	417	358 760 X91	329, 334, 338, 345	363 593 X1	370	376 478 X1	274, 277
355 118 X1	138	358 762 X91	329, 334, 338, 345, 349	363 623 X1	209, 301	376 503 X1	102, 105
		358 781 X91	253, 306, 309	363 704 X1	354	376 521 X1	102, 105
		358 782 X91	329, 338, 349, 350	364 105 X1	369	376 524 X1	102, 105
				364 159 X1	354	376 525 X1	102, 105
				364 189 X1	301, 310	376 526 X1	105
				364 258 X1	313	376 720 X1	209
				364 259 X1	Use 364 258 X1	376 721 X1	286
				364 281 X1	362	376 760 X1	121, 333, 334, 342, 345, 434
				364 559 X1	330, 341	376 762 X1	354
				364 561 X1	330, 341	376 763 X1	417
				364 562 X1	330, 341	376 768 X1	293, 297
						376 781 X1	370
						376 783 X1	117

NUMERICAL INDEX - MF NUMBERS
 INDEX NUMERIQUE - MF NUMEROS
 NUMMERN - INDEX - MF NUMMERS
 INDICE NUMERICO - MF NUMEROS

Part No.	See Page	Part No.	See Page	Part No.	See Page	Part No.	See Page
376 804 X1	117	504 823 M1	310	557 660	349	825 039 M1	290
376 805 X1	297, 370	504 882 M1	253	557 661	349	825 040 M1	290
376 806 X1	117	505 350 M1	185	557 662	350	825 041 M1	290
376 807 X1	Use 22 370 X	505 351 M1	185	557 663	334	825 064 M1	290
376 816 X1	145	506 183 M1	253	557 664	345	825 292 M1	281
376 846 X1	426	506 184 M1	253	634 037 M1	109	825 302 M1	85, 86
376 848 X1	138	506 322 M92	Use 513 624 M1	643 613 M1	209	825 776 M1	261, 265
376 857 X1	277	506 667 M1	253	645 677 M1	410, 413	826 237 M1	370
376 859 X1	213	506 782 M1	310, 313	645 917 M1	421	826 238 M1	370, 433, 434
376 863 X1	342	506 869 M91	358	645 923 M1	421	826 772 M1	97
376 864 X1	333, 334, 342, 345	506 873 M91	358	645 933 M1	421	826 809 M1	89
376 929 X1	313	506 876 M1	362	646 059 M1	170	826 897 M1	146
377 014 X1	281	506 877 M1	362	646 663 M91	433	827 150 M1	290
377 045 X1	146	506 985 M1	310, 313	646 669 M1	433, 434	827 718 M2	301, 302
377 046 X1	Use 377 978 X1	506 992 M1	Use 884 389 M1	646 670 M91	434	827 854 M1	166
377 055 X1	166	506 993 M91	369	675 222 M1	417	827 877 M1	121, 122
377 062 X1	310, 313	506 994 M91	369	731 352 M1	102, 105	827 901 M1	146, 162
377 063 X1	310, 313	506 995 M1	369	731 353 M1	102, 105	828 020 M1	222, 229, 233, 241
377 067 X1	145	508 164 M91	313	731 364 M1	Use 884 748 M1		
377 078 X1	146	508 354 M1	238	762 026 M1	362	828 039 M1	89, 93
377 105 X1	413	508 575 M1	369	762 101 M1	234, 245	828 049 M1	121
377 106 X1	422	508 974 M1	310, 313	762 191 M1	278	828 123 M1	85, 86
377 108 X1	422	508 975 M1	310, 313	763 342 M1	354	828 217 M1	166
377 110 X1	422	508 976 M1	310, 313	764 805 M92	286	828 224 M1	145, 153
377 111 X1	422	509 035 M1	310	768 300 M1	238	828 301 M1	145, 154
377 112 X1	422	509 037 M91	310	791 265 M91	170	828 498 M1	190, 205, 206, 209
377 119 X1	117	509 040 M91	310	810 285 M92	257, 390, 393, 414, 421	828 577 M1	190, 205, 206, 209
377 174 X1	173, 177	510 241 M1	245	811 201 M91	410, 413	828 583 M91	98, 101
377 201 X1	153, 154	510 710 M1	278	812 157 M1	434	828 655 M1	117
377 213 X1	446	512 784 M1	253	812 560 M1	434	828 656 M1	117
377 215 X1	386	512 854 M1	334, 345	812 561 M1	434	828 665 M1	409
377 225 X1	354	512 982 M91	174	816 339 M1	437	828 666 M1	409
377 226 X1	354	513 039 M91	273	818 150 M1	433, 434	828 790 M2	146
377 227 X1	278	513 166 M1	278	818 151 M1	433, 434	828 801 M1	281, 293
377 230 X91	366	513 176 M1	278	818 152 M1	Use 831 461 M1	828 805 M1	281, 293
377 233 X91	366	513 242 M1	278	818 153 M1	433, 434	828 874 M1	157, 162
377 235 X1	157	513 592 M91	309	818 154 M1	Use 646 670 M1	828 915 M92	Use 1886 535 M91
377 244 X1	Use 1863 466 M1	513 624 M91	Use 515 113 M93	818 155 M1	433, 434	828 927 M91	Use 1886 535 M91
377 262 X1	413	513 636 M1	309	818 177 M92	421	829 032 M1	414
377 291 X1	173, 177	513 800 M1	174	818 257 M91	421	829 092 M1	281
377 355 X1	274, 277, 334	514 210 M1	278	818 261 M91	421	829 258 M1	190, 205, 206, 209
377 359 X1	450, 453, 458, 461, 462	514 239 M1	309	818 263 M1	421	829 259 M1	190, 205, 206, 209
377 378 X1	277	515 072 M1	310, 313	818 264 M1	421	830 735 M91	225, 237, 245
377 386 X1	302	515 113 M93	310	818 264 M1	421	831 117 M1	374
377 461 X1	417	515 957 M1	306, 314	818 264 M1	421	831 130 M1	301
377 505 X91	349, 350	515 960 M91	306, 314	818 264 M1	421	831 144 M1	222
377 507 X91	349	515 961 M1	306, 314, 318	818 264 M1	421	831 187 M1	Use 195 507 M1
377 512 X91	350	515 962 M1	306, 314	818 264 M1	421	831 220 M1	417
377 522 X1	326	515 963 M1	306, 314	818 264 M1	421	831 236 M1	417
390 961 X1	469	515 964 M1	306, 314	818 264 M1	421	831 262 M1	390
390 972 X1	221	515 966 M1	306, 314	818 264 M1	421	831 263 M1	382, 386
390 981 X1	218, 221	515 967 M91	306, 314	818 264 M1	421	831 420 M1	178
391 056 X1	469, 470, 473, 474, 478, 481, 485	516 259 M2	306, 314, 318	818 264 M1	421	831 447 M1	354
391 074 X1	470	516 276 M91	314, 318	818 264 M1	421	831 452 M1	193, 194, 197, 253, 301, 302, 306, 309, 310, 313, 314, 318, 322, 326, 330, 341, 349, 350, 366
391 364 X1	473	516 364 M1	278	818 264 M1	421	831 461 M1	358, 433, 434
391 382 X1	270	516 523 M92	245	818 264 M1	421	831 469 M1	Use 1866 071 M1
391 415 X1	221	518 359 M1	301	818 264 M1	421	831 485 M1	310, 313
391 838 X1	233	518 822 M1	309, 318	818 264 M1	421	831 495 M1	329, 334, 338, 345
491 050 M2	378	519 205 M2	358	818 264 M1	421		
491 105 M1	378	520 700 M2	225, 226, 245	818 264 M1	421		
503 307 M1	446	520 701 M1	245	818 264 M1	421		
504 118 M2	358	522 755 M1	358	818 264 M1	421		
504 149 M1	358	522 756 M1	358	818 264 M1	421		
504 822 M1	306, 310, 313, 314	557 489	366	818 264 M1	421		
		557 555	446	818 264 M1	421		
		557 556	446	818 264 M1	421		
		557 655	334	818 264 M1	421		
		557 656	345	818 264 M1	421		
		557 657	337	818 264 M1	421		
		557 659	346	818 264 M1	421		
				824 455 M1	410		
				824 456 M91	410		
				824 458 M91	410		
				824 481 M91	429		
				824 483 M91	Use 824 450 M91		
				824 490 M93	Use 1884 943 M92		
				824 702 M91	421		
				824 705 M1	421		
				824 713 M91	421		
				824 715 M91	421		
				825 031 M2	354, 370		