

NISSAN Learning Academy

Nissan Australia. July 2008



ZD30DDTi Common Rail Diesel Engine

**Y61 Patrol Wagon
UY61 Cab Chassis**

Foreword

The information in this Training Manual should not be interpreted as a basis for warranty or goodwill claims against Nissan Motor Co. (Australia) Pty. Ltd. (NMA) unless so designated.

This Technical Training Manual is intended for use by NMA & Nissan Dealership Technical Personnel. It is not designed for the use by press or for customer distribution.

Before quoting any specifications be sure to check the relevant Service Manual and Technical Bulletins.

Right for alteration to data and specifications at any time is reserved. Any such alterations will be advised by Nissan through Technical and Sales Bulletins.

©2008 Nissan Motor Company (Australia) Pty. Ltd.
Inc. Victoria

Ref: Technical Training Department.

ABOUT THIS TRAINING MANUAL

The purpose of this document is for Nissan Dealer Technical Staff SELF STUDY purposes. If anything contained within this document gives any doubt, please contact Nissan via a Non Vehicle related TechLine enquiry to clarify the information within this document.

The information in this training manual should not be interpreted as a basis for warranty or goodwill claims against Nissan Motor Co. (Australia) Pty. Ltd. (NMA) unless so designated.

FUTURE UPDATE'S OF THIS TRAINING MANUAL?

Additional information will be collated & added to this document at a later date. When this does occur, a special amendment document will be published on the new Nissan Learning Academy.

Go to www.nissanlearningacademy.com.au for more detail.

This actual Training Manual will also be readily available at anytime for download & printing within each Nissan Dealership.

Y61 SERVICE MANUAL (ESM)

All Y61 (1997 ~ 2008 >); **SM7E-5Y61G3**

This ESM has been automatically issued to ALL Nissan dealers (via the parts distribution system) If your dealership does not have one, they can be ordered via normal parts channels using the above quoted publication numbers..

This Training Manual is designed for the purpose of relaying information about the vehicle & the systems within it. This Training Manual is NOT to be used as the Service Manual. Throughout this Training Manual, references are made to the Service Manual for additional information regarding fault diagnosis, repairs &/or maintenance.

Once again should there be any doubt, please contact TechLine.

SERVICE TECHNICAL BULLETINS (STB's)

Please ensure you familiarise yourselves with all STB's relating to Y61

Once the screen where all STB's are accessed, click on the "by Model" link & then all the STB's will be re-sorted so that all the model code related STB's are together.

1. Click on "by Model"

2. Look for the vehicle model code from the list

How to use the Y61 Service Manual (ESM) SM7E-5Y61G3

This image below is what appears on the screen of the computer when the ESM (CD) is installed in the disc drive of the computer, a window (which will automatically appear) containing an icon called "Start" is double clicked & then the button marked "Service Manual" is clicked on.

NISSAN
Y61

~~Technical Bulletin~~

Return to Start Page

Service Manual List

Item	Applicable from	Check VIN Code	Publication No.	LINK	
Y61 Supplement for Australia	Sep.2007	Go!	TB(SM07-96)	Click !	← 1 CD only
Supplement X 1st Revision	Jan.2007	Go!	SM7E-Y61KG1	Click !	← 2 CD only
Supplement IX 1st Revision	Jun.2006	Go!	SM6E-Y61JG1	Click !	← 3 CD only
Supplement VIII 1st Revision	Jun.2004	Go!	SM4E-Y61HG1	Click !	← 4 CD & Book
Supplement VII 2nd Revision	Sep.2003	Go!	SM4E-Y61GG2	Click !	NFA
Supplement VI 1st Revision	Jun.2002	Go!	SM2E-Y61FG1	Click !	← 5 CD & Book
Supplement V 1st Revision	Jun.2001	Go!	SM1E-Y61EG1	Click !	← 6 CD & Book
Supplement IV	Jul.2000	Go!	SM6E-Y61DG0	Click !	NFA
Supplement III 3rd Revision	Jul.1999	Go!	SM9E-Y61CG3	Click !	← 7 CD & Book
Supplement II 1st Revision	Feb.1999	Go!	SM9E-Y61BG1	Click !	← 8 CD & Book
Supplement I	Jul.1998	Go!	SM8E-Y61AG0	Click !	← 9 CD & Book
First Edition 1st Rev.Volume 1	Oct.1997		SM7E-1Y61G1	Click !	← 10 CD & Book
First Edition 1st Rev.Volume 2	Oct.1997		SM7E-2Y61G1	Click !	←

Copyright © 2007 NISSAN MOTOR CO.,LTD. All Rights Reserved NFA = Not For Australia

DO NOT refer to these Tech Bulletins. Only refer to STB's released by Nissan Australia. They're located on INISCOM.

This new ESM supersedes ESM SM6E-5Y61G1 & SM7E-5Y61G2. Discard them & only refer to SM7E-5Y61G3.

- 1 Supplement for Australia. This is for Cab Chassis variants with the ZD30-CRD engine.
- 2 Supplement X (10) for 2007 production vehicles (Primarily for ZD30-CRD engine vehicles)
- 3 Supplement IX (9) for 2006 production vehicles (Primarily for Euro III TB48DE engine vehicles)
- 4 Supplement VIII (8) for (late) 2004 ~ 2005 production vehicles. Major facelift with no mechanical changes.
- 5 Supplement VI (6) for 2003 production vehicles (Primarily for TD42 engine with turbo, intercooler & electronic fuel pump).
- 6 Supplement V (5) for (late) 2001 ~ 2002 production vehicles (Primarily for TB48DE engine vehicles)
- 7 Supplement III (3) for 2000 ~ 2001 production vehicles. (Primarily for ZD30 engine vehicles)
- 8 Supplement II (2) for 1999 production vehicles. (Primarily for TD42 with turbo only engine vehicles)
- 9 Supplement I (1) for 1998 (Minor running changes made. Typically wiring diagrams)
- 10 Original Service Manuals (Vol 1 & Vol 2) introduced in late 1997. Refer to these for information on TD42 non turbo, TB45E & RD28ETi engine vehicles.

BEWARE: Always select the manual relevant to the VIN. If the required detail cannot be found in that particular Supplement, simply go back to the next supplement down the list.

The basic rule of thumb is **start from the newest supplement** (or supplement relevant to the VIN / age of the vehicle) & work **backwards** until the required information is found.

NISSAN Learning Academy

ZD30DDTi CRD Engine

Nissan Australia July 2008

History & Service Manual Reference - Y61 Patrol 1997 ~ 2008

Service Man reference.	(Prod'd from) VIN	Model Year	Comments regarding changes	Nissan Australia derived "Series" coding
*Supp X	JN1TESY61A0395001	2007MY ZD30	New ZD30 - CRD Engine with ASCD	Series V & VI ZD30-CRD engine with ASCD & CAN. TB48 no change since '06 Euro III. TD42 no longer available. Mid 2007 changes: ABS standard on all except DX. Special DX variant with 16" alloy wheels introduced.
	JN1TFSY61A0366001	2007MY TB48	No change from '06MY	
*Supp IX	JN1TESY61A0385001	2006MY ZD30	1 piece key but no other change from '05MY	Series IV From August '04 production. Major Cosmetic Changes. Ti with Sat Nav/Rev Camera. All new Interior. Trim colour options. New style 5 spoke 17" alloy wheels. Larger square shaped wheel arch flares. Larger rear taillights. New headlights, bumper & grille. Available in DX, ST, ST-S, ST-L for ZD30 & TD42 engines. ST-S, ST-L & Ti for TB48 engines. Changes for 2006: 1 peice key/remote (except DX). Euro III TB48. New Sat Nav/Rev Camera system for Ti & option of ZD30 Ti variant from Sep't '06.
	JN1TCSY61A0365001	2006MY TD42	1 piece key but no other change from '05MY	
	JN1TFSY61A0365001	2006MY TB48	1 piece key, Euro III engine, No Sub Tank & No M/T	
*Supp VIII	JN1TESY61A0370001	2005MY ZD30	Major Facelift + increase in Power & Torque for M/T	Changes for 2006: 1 peice key/remote (except DX). Euro III TB48. New Sat Nav/Rev Camera system for Ti & option of ZD30 Ti variant from Sep't '06.
	JN1TCSY61A0360001	2005MY TD42	Major Facelift only. Mech unchanged	
	JN1TFSY61A0360001	2005MY TB48	Major Facelift only. Mech unchanged	
*Supp VI	JN1TESY61A0345001	2003MY ZD30	No change from '02MY	Series III From late 2001 production. Changes to taillights, headlights & grill. New style (6 spoke) 16" alloy wheels & new style Nissan Badges. New TB48DE petrol engine with 5 sp A/T. Changes for 2003: New TD42Ti (turbo intercooled) diesel engine with Cruise Control (except DX). New ST-L variant with rear A/C & leather trim introduced. ST-L available in all engine & transmission combinations.
	JN1TCSY61A0345001	2003MY TD42	New TD42Ti Engine with Cruise Control	
	JN1TFSY61A0345001	2003MY TB48	No change from '02MY	
*Supp V	JN1TESY61A0330001	2002MY ZD30	Facelift only	Changes for 2003: New TD42Ti (turbo intercooled) diesel engine with Cruise Control (except DX). New ST-L variant with rear A/C & leather trim introduced. ST-L available in all engine & transmission combinations.
	JN1TCSY61A0330001	2002MY TD42	Facelift only	
	JN1TFSY61A0330001	2002MY TB48	Facelift & new TB48DE engine & 5 sp. A/T	
*Supp III	JN1TESY61A0300001	2000MY ZD30	Minor facelift & new ZD30 engine	Series II Minor facelift. New ZD30 engine for DX & ST. Ti gains side SRS airbags. ST gains keyless entry - hazards flash, Ti same. ST gains dual Airbag/ABS ("Safety Pack") as option. Drivers power window gains "Anti Pinch" function. TD42T (turbo) engine available in DX & ST. NATS on all engine options.
	JN1TCSY61A0300001	2000MY TD42	Minor Facelift & NATS	
	JN1TBSY61A0300001	2000MY TB45	Minor Facelift only	
*Supp II	JN1TCSY61A0110001	1999MY TD42	TD42T engine intro running change. ST only	Series I Y61 launched in December 1997 with TB45E engine only (ST & Ti). RD28ETi in ST & DX introduced January 1998. TD42 (non turbo) in DX only introduced in March 1998. NATS available on ALL models except TD42 engine. Keyless Entry ONLY on Ti variants - hazards do NOT flash. Changes for 1999: TD42T (turbo) introduced to ST wagons (along with intro of Cab Chassis). NATS not available on TD engine wagons.
*Supp I	JN1TDSY61A0110001	1998MY RD28	No change from original production	
	JN1TCSY61A0110001	1998MY TD42	No change from original production	
	JN1TBSY61A0110001	1998MY TB45	No change from original production	
*Original Manuals (Vol 1 & Vol 2)	JN1TDSY61A0100001	1998MY RD28	Original production	Changes for 1999: TD42T (turbo) introduced to ST wagons (along with intro of Cab Chassis). NATS not available on TD engine wagons.
	JN1TCSY61A0100001	1998MY TD42	Original production	
	JN1TBSY61A0100001	1998MY TB45	Original production	

Y61 Patrol Cab Chassis

*Supp for Australia	JN1UENY610000101	2008MY ZD30	Introduction of the ZD30-CRD engine	Series III Series IV wagon front styling has been adopted with the ZD30-CRD engine.
	JN1UELY610500101	2008MY ZD30		
*Supp X	JN1UCNY61A0026844	2006MY TD42	Introduction of SRS Airbags	Series II New TD42Ti Turbo I'cooled engine, new radiator, new grille & headlights for 2003 (front styling of Ser III wagon, interior style of Ser I wagon continues unchanged). NATS, Keyless Entry and Cruise Control NOT available on C/C. From October 2006: Dual SRS Airbag fitted to all variants except Coil DX.
	JN1UCLY61A0524673	2006MY TD42		
*Supp VI	JN1UCNY61A0020101	2003MY TD42	Facelift & new TD42Ti engine	From October 2006: Dual SRS Airbag fitted to all variants except Coil DX.
	JN1UCLY61A0520101	2003MY TD42		
*Supp II (& Original Manuals)	JN1UCNY61A0000101	1999MY TD42	Original production	Series I Y61 C/C launched Feb '99. Intro of TD42T (turbo) for C/C & ST Wagon. No NATS or Keyless Entry.
	JN1UCLY61A0500101	1999MY TD42	Original production	

* Refer to this Service Manual / SM Supplement if the VIN matches or is HIGHER than the VIN shown to the right (but not higher than the VIN quoted in the group above). If the information cannot be found in a Supplement Manual, simply refer back to EARLIER Service Manual Supplements (go back 1 Manual at a time) until the information is located.
Finding NO information on a specific system in the Supplement for a VIN simply means no change occurred on that specific system for that VIN breakpoint. Go back 1 Manual at a time until the required information is found.

ZD30 ENGINE CODE DESCRIPTION

Y61 Diesel Engines .../Cont'd

ZD30DDTi (4 cylinder diesel engine)

ZD = Engine series code. The 'D' is common across all diesel engine codes

30 = Engine capacity (3.0L)

D = Double Overhead camshafts

D = Direct Injection (as opposed to "indirect" injection as it is in the TD & RD engine series)

T = Turbo

i = intercooler

Note 1; None of the coding makes any reference to Electronic Control even though it is an electronically controlled engine.

Note 2; The same code applies to the CRD (Common Rail Diesel) version of this engine.

Note 3; All ZD30 engines are fitted with NATS (wagon only).

Note 4; Only ZD30 CRD engines from 2007 production have ASCD (Cruise Control – wagon only).

Note 5; ZD30 engine also applied to D22 Navara models from late 2001 ~ 2006 production. Engine has a conventional turbo, but no intercooler. (ZD30DDT)



ZD30DDTi (Non CRD; 2000 ~ 2006)



ZD30DDTi (CRD; 2007)



Rocker Cover ZD30DDTi CRD (2007)



Rocker Cover ZD30DDTi (2000 ~ 2006)

NISSAN Learning Academy

ZD30DDTi CRD Engine

Nissan Australia July 2008

ENGINE MECHANICAL - EM

2007 ZD30DDTi Common Rail Diesel (CRD) Engine

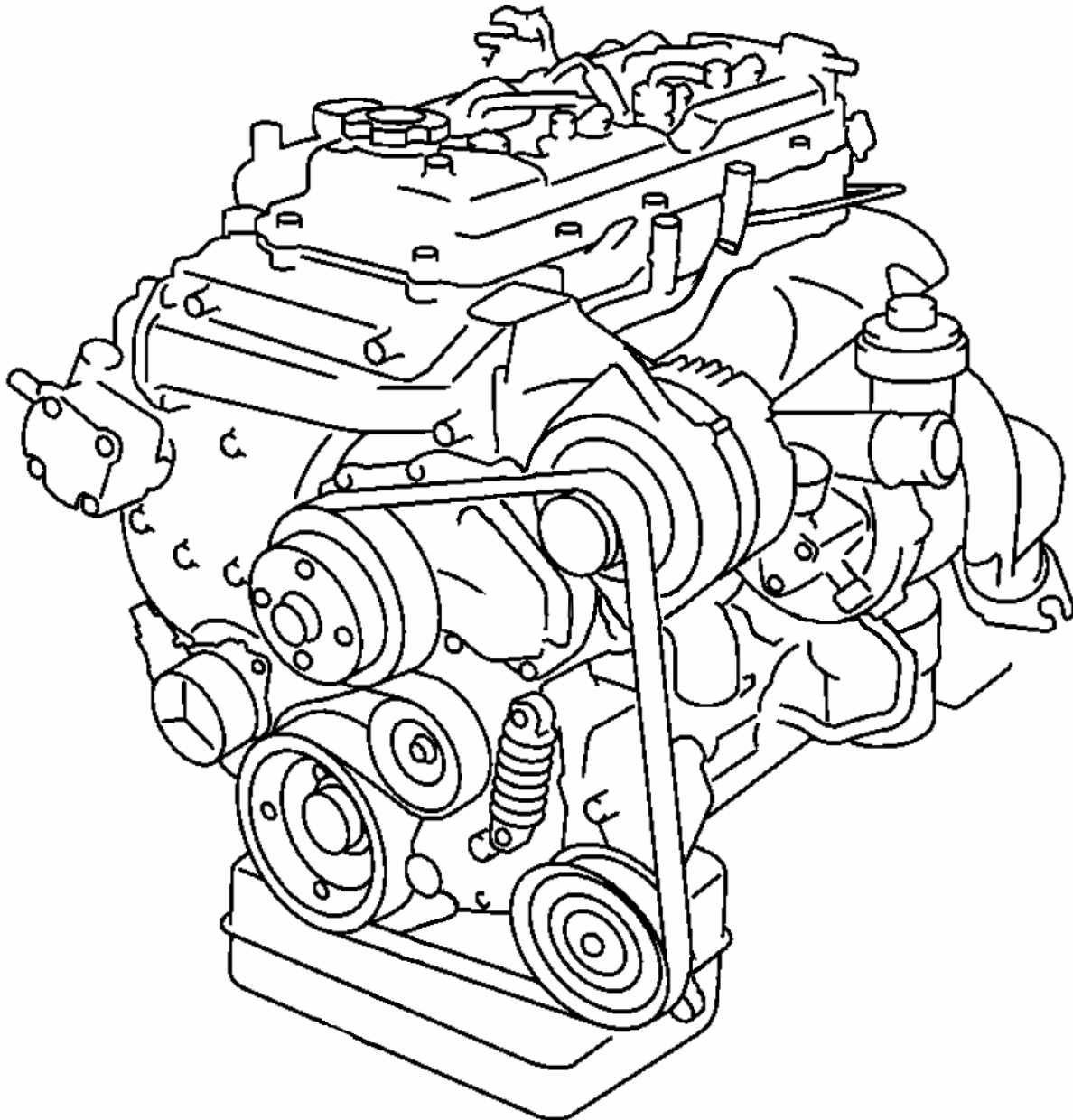

With the introduction of the 2007 MY Y61 Patrol, the Diesel Engine range has now been revised with the introduction of the ZD30DDTi CRD Engine.

This new Engine is now the only Diesel Engine option available for Y61 wagon & cab chassis variants. The TD42Ti engine has been discontinued as it does not comply to strict new ADR 79/01 (Euro IV) emission standards.

Transmission options for the new ZD30 engine in Y61 is either 5 M/T or 4 E-A/T which have been carried over from the previous models.

All Y61 ZD30 wagon variants are now fitted with ASCD (Cruise Control) as standard.