

QUICK REFERENCE CHART : G20 1993

ENGINE TUNE-UP DATA

Engine model	SR20DE		
Firing order	1-3-4-2		
Idle speed	rpm	M/T A/T (in "N" position)	800±50
Ignition timing (B.T.D.C. at idle speed)	15°±2°		
CO% at idle	Idle mixture screw is preset and sealed at factory.		
Drive belt deflection (Cold)	mm (in)	Used belt deflection	
		Limit	Deflection after adjustment
Alternator	With air conditioner compressor	11.5 - 12.5 (0.453 - 0.492)	7 - 8 (0.28 - 0.31)
	Without air conditioner compressor	12 - 13 (0.47 - 0.51)	8 - 9 (0.31 - 0.35)
Power steering oil pump		6 - 7 (0.24 - 0.28)	4 - 5 (0.16 - 0.20)
			3.5 - 4.5 (0.138 - 0.177)
Applied pushing force	N (kg, lb)	98 (10, 22)	
Radiator cap relief pressure	kPa (kg/cm ² , psi)	78 - 98 (0.8 - 1.0, 11 - 14)	
Cooling system leakage testing pressure	kPa (kg/cm ² , psi)	157 (1.6, 23)	
Compression pressure	Standard	1,226 (12.5, 178)/300	
	Minimum	1,030 (10.5, 149)/300	
Spark plug	Type (Standard)	PFR5B-11, BKR6E	

FRONT WHEEL ALIGNMENT (Unladen*)

Camber	degree	-0°45' to 0°45'	
Caster	degree	1°05' - 2°35'	
Kingpin inclination	degree	13°45' - 15°15'	
Toe-in			
	A - B	mm (in)	0 - 2 (0 - 0.08)
	Total angle 2θ	degree	0' - 12'
Wheel turning angle (Full turn)	degree		
	Inside		33° - 37°
	Outside		28° - 32°

* Fuel, radiator coolant and engine oil full.
Spare tire, jack, hand tools and mats in designated positions.

REAR WHEEL ALIGNMENT (Unladen*)

Camber	degree	-1°45' to -0°15'
Toe-in		
	A - B	mm (in)
Total angle 2θ	degree	-12' to 12'

* Fuel, radiator coolant and engine oil full.
Spare tire, jack, hand tools and mats in designated positions.

BRAKE

Unit: mm (in)

Front brake			
Pad wear limit		2.0 (0.079)	
Rotor repair limit		20.0 (0.787)	
Rear brake			
Pad wear limit		2.0 (0.079)	
Rotor repair limit		8.0 (0.315)	
Pedal free height			
	M/T	For CANADA	151 - 161 (5.94 - 6.34)
	A/T	Except for Canada	158 - 168 (6.22 - 6.61)
			159 - 169 (6.26 - 6.65)
Pedal depressed height*	M/T		80 (3.15) or more
	A/T		85 (3.35) or more

* Under force of 490 N (50 kg, 110 lb) with engine running

REFILL CAPACITIES

Unit		Liter	US measure
Fuel tank		60	15-7/8 gal
Coolant (With reservoir tank)	M/T	6.1	6-1/2 qt
	A/T	6.5	6-7/8 qt
Engine	With oil filter	3.4	3-5/8 qt
	Without oil filter	3.2	3-3/8 qt
Transaxle	M/T	3.5 - 3.7	3-3/4 - 3-7/8 qt
	A/T	7.0	7-3/8 qt
Power steering system		0.9	1 qt
Air conditioning system	Compressor oil	0.2	6.8 fl oz
	Refrigerant	0.70 - 0.80 kg	1.54 - 1.76 lb

QUICK REFERENCE INDEX

GENERAL INFORMATION _____	GI
MAINTENANCE _____	MA
ENGINE MECHANICAL _____	EM
ENGINE LUBRICATION & COOLING SYSTEMS _____	LC
ENGINE FUEL & EMISSION CONTROL SYSTEM _____	EF & EC
ACCELERATOR CONTROL, FUEL & EXHAUST SYSTEMS _____	FE
CLUTCH _____	CL
MANUAL TRANSAXLE _____	MT
AUTOMATIC TRANSAXLE _____	AT
FRONT AXLE & FRONT SUSPENSION _____	FA
REAR AXLE & REAR SUSPENSION _____	RA
BRAKE SYSTEM _____	BR
STEERING SYSTEM _____	ST
BODY _____	BF
HEATER & AIR CONDITIONER _____	HA
ELECTRICAL SYSTEM _____	EL



I N F I N I T I

G20

MODEL P10 SERIES



I N F I N I T I

© 1992 NISSAN MOTOR CO., LTD. Printed in Japan

Not to be reproduced in whole or in part without the prior written permission of Nissan Motor Company Ltd., Tokyo, Japan.

FOREWORD

This manual contains maintenance and repair procedures for the 1993 INFINITI G20.

In order to assure your safety and the efficient functioning of the vehicle, this manual should be read thoroughly. It is especially important that the PRECAUTIONS in the GI section be completely understood before starting any repair task.

All information in this manual is based on the latest product information at the time of publication. The right is reserved to make changes in specifications and methods at any time without notice.

IMPORTANT SAFETY NOTICE

The proper performance of service is essential for both the safety of the technician and the efficient functioning of the vehicle.

The service methods in this Service Manual are described in such a manner that the service may be performed safely and accurately.

Service varies with the procedures used, the skills of the technician and the tools and parts available. Accordingly, anyone using service procedures, tools or parts which are not specifically recommended by INFINITI must first completely satisfy himself that neither his safety nor the vehicle's safety will be jeopardized by the service method selected.



I N F I N I T I [®]



NISSAN MOTOR CO., LTD.

Overseas Service Department

Tokyo, Japan

GENERAL INFORMATION

SECTION **GI**

GI

MA

EM

LC

EF &
EC

FE

CL

MT

AT

FA

RA

BR

ST

BF

HA

EL

CONTENTS

PRECAUTIONS	2	Checking Equipment.....	13
General Precautions.....	2	IDENTIFICATION INFORMATION	14
Precautions for Multiport Fuel Injection System or E.C.C.S. Engine.....	3	Model Variation.....	14
Precautions for Three Way Catalyst.....	4	Identification Number.....	15
Precautions for Fuel.....	4	Dimensions.....	17
HOW TO USE THIS MANUAL	5	Wheels and Tires.....	17
HOW TO READ WIRING DIAGRAMS	7	LIFTING POINTS AND TOW TRUCK TOWING	18
HOW TO FOLLOW FLOW CHART IN TROUBLE		Preparation.....	18
DIAGNOSES	10	Board-on Lift.....	18
CONSULT CHECKING SYSTEM	13	Garage Jack and Safety Stand.....	19
Function and System Application.....	13	2-pole Lift.....	19
Lithium Battery Replacement.....	13	Tow Truck Towing.....	20
		TIGHTENING TORQUE OF STANDARD BOLTS	21

PRECAUTIONS

Observe the following precautions to ensure safe and proper servicing. These precautions are not described in each individual section.

General Precautions

1. Do not operate the engine for an extended period of time without proper exhaust ventilation. Keep the work area well ventilated and free of any inflammable materials. Special care should be taken when handling any inflammable or poisonous materials, such as gasoline, refrigerant gas, etc. When working in a pit or other enclosed area, be sure to properly ventilate the area before working with hazardous materials. Do not smoke while working on the vehicle.
2. Before jacking up the vehicle, apply wheel chocks or other tire blocks to the wheels to prevent the vehicle from moving. After jacking up the vehicle, support the vehicle weight with safety stands at the points designated for proper lifting and towing before working on the vehicle. These operations should be done on a level surface.
3. When removing a heavy component such as the engine or transaxle/transmission, be careful not to lose your balance and drop them. Also, do not allow them to strike adjacent parts, especially the brake tubes and master cylinder.
4. Before starting repairs which do not require battery power, always turn off the ignition switch, then disconnect the ground cable from the battery to prevent accidental short circuit.
5. To prevent serious burns, avoid contact with hot metal parts such as the radiator, exhaust manifold, tail pipe and muffler. Do not remove the radiator cap when the engine is hot.

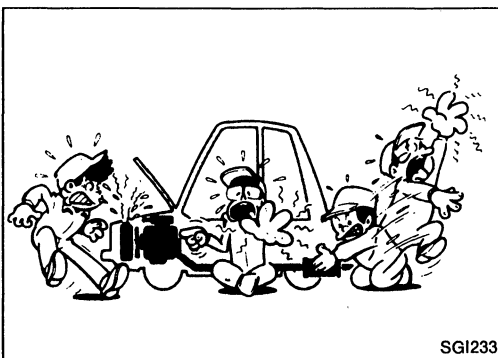
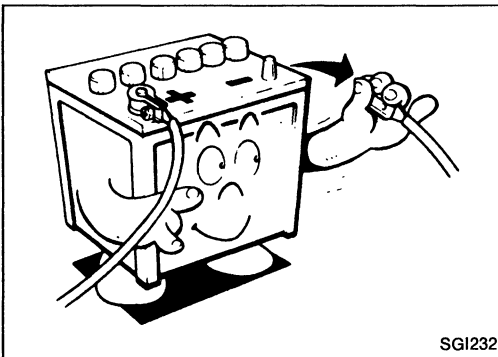
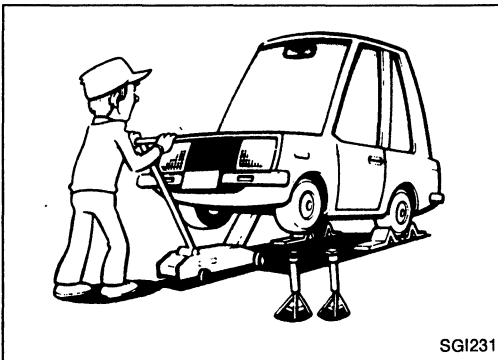
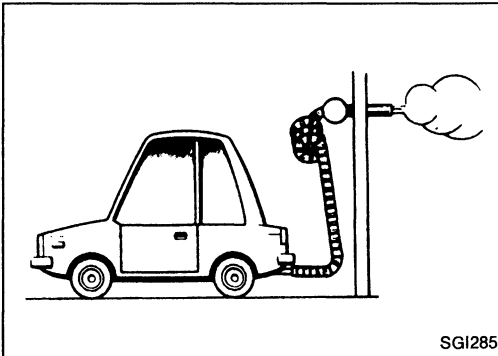

PRECAUTIONS

General Precautions (Cont'd)

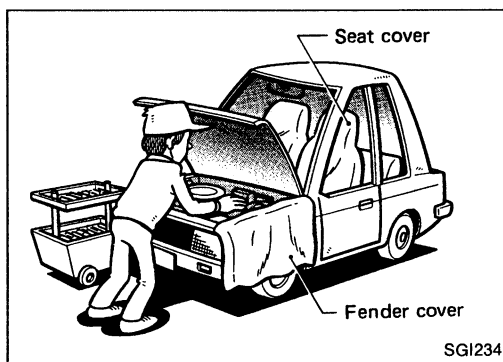

6. Before servicing the vehicle, protect fenders, upholstery and carpeting with appropriate covers. Take caution that keys, buckles or buttons on your person do not scratch the paint.

7. Clean all disassembled parts in the designated liquid or solvent prior to inspection or assembly.
8. Replace oil seals, gaskets, packings, O-rings, locking washers, cotter pins, self-locking nuts, etc. with new ones.
9. Replace inner and outer races of tapered roller bearings and needle bearings as a set.
10. Arrange the disassembled parts in accordance with their assembled locations and sequence.
11. Do not touch the terminals of electrical components which use microcomputers (such as ECMs). Static electricity may damage internal electronic components.
12. After disconnecting vacuum or air hoses, attach a tag to indicate the proper connection.
13. Use only the lubricants specified in MA section.
14. Use approved bonding agent, sealants or their equivalents when required.
15. Use tools and recommended special tools where specified for safe and efficient service repairs.
16. When repairing the fuel, oil, water, vacuum or exhaust systems, check all affected lines for leaks.
17. Dispose of drained oil or the solvent used for cleaning parts in an appropriate manner.

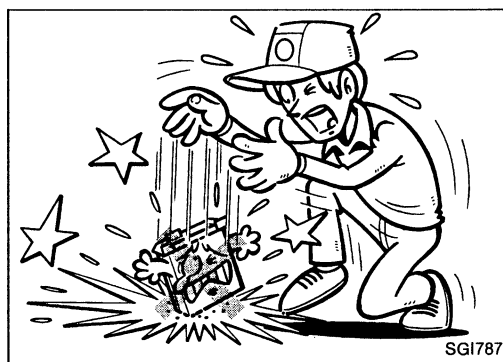

Precautions for Multiport Fuel Injection System or E.C.C.S. Engine

1. Before connecting or disconnecting multiport fuel injection system or E.C.C.S. harness connector to or from any multiport fuel injection system or ECM (ECCS control module), be sure to turn the ignition switch to the "OFF" position and disconnect the negative battery terminal. Otherwise, there may be damage to ECM.
2. Before disconnecting pressurized fuel line from fuel pump to injectors, be sure to release fuel pressure to eliminate danger.
3. Be careful not to jar components such as ECM and mass air flow sensor.

GI

MA

EM

LC

EF &
EC

FE

CL

MT

AT

FA

RA

BR

ST

BF

HA

EL

PRECAUTIONS

Precautions for Three Way Catalyst

If a large amount of unburned fuel flows into the three way catalyst, the three way catalyst temperature will be excessively high. To prevent this, follow the procedure below:

1. Use unleaded gasoline only. Leaded gasoline will seriously damage the three way catalyst.
2. When checking for ignition spark or measuring engine compression, make tests quickly and only when necessary.
3. Do not run engine when the fuel tank level is low, otherwise the engine may misfire causing damage to the three way catalyst.
4. Do not place the vehicle on inflammable material. Keep inflammable material off the exhaust pipe.

Precautions for Fuel

Use unleaded gasoline with an octane rating of at least 87 AKI (Anti-Knock Index) number (research octane number 91).

CAUTION:

Do not use leaded gasoline. Using leaded gasoline will damage the three way catalyst.

HOW TO USE THIS MANUAL

1. **A QUICK REFERENCE INDEX**, a black tab (e.g. **BR**) is provided on the first page. You can quickly find the first page of each section by mating it to the section's black tab.
2. **THE CONTENTS** are listed on the first page of each section.
3. **THE TITLE** is indicated on the upper portion of each page and shows the part or system.
4. **THE PAGE NUMBER** of each section consists of two letters which designate the particular section and a number (e.g. "BR-5").
5. **THE LARGE ILLUSTRATIONS** are exploded views (See below.) and contain tightening torques, lubrication points and other information necessary to perform repairs. The illustrations should be used in reference to service matters only. When ordering parts, refer to the appropriate **PARTS CATALOG**.

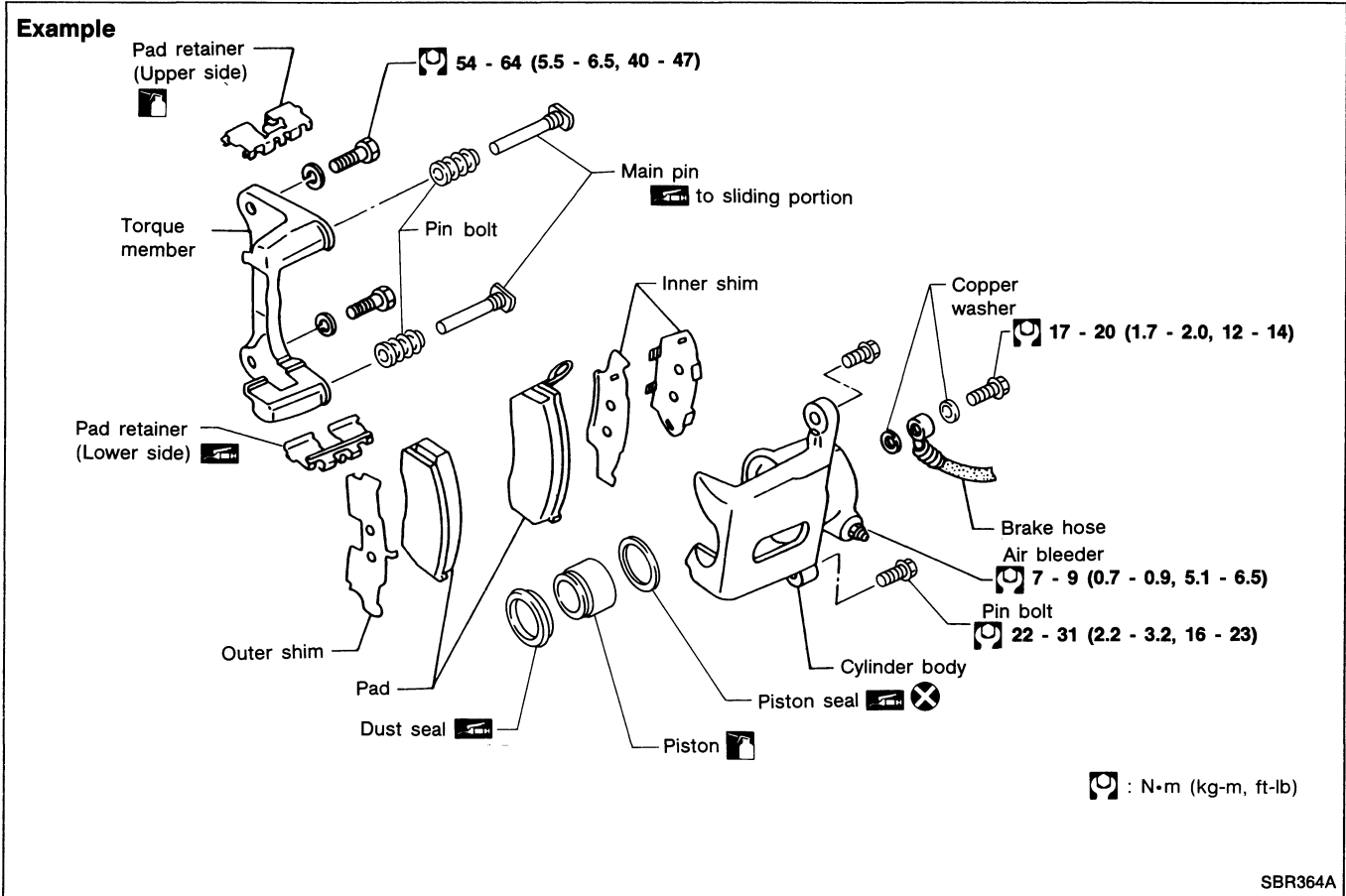

6. **THE SMALL ILLUSTRATIONS** show the important steps such as inspection, use of special tools, knacks of work and hidden or tricky steps which are not shown in the previous large illustrations. Assembly, inspection and adjustment procedures for complicated units such as the automatic transaxle or transmission, etc. are presented in a step-by-step format where necessary.
7. The following **SYMBOLS AND ABBREVIATIONS** are used:

	: Tightening torque	☆	: Adjustment is required.
	: Should be lubricated with grease. Unless otherwise indicated, use recommended multi-purpose grease.	S.D.S.	: Service Data and Specifications
	: Should be lubricated with oil.	L.H.	: Left-Hand
	: Sealing point	A/T	: Automatic Transaxle/Transmission
	: Checking point	Tool	: Special Service Tools
	: Always replace after every disassembly.	A.T.F.	: Automatic Transmission Fluid
	: Apply petroleum jelly.	D ₁	: Drive range 1st gear
	: Apply A.T.F.	D ₂	: Drive range 2nd gear
★	: Select with proper thickness.	D ₃	: Drive range 3rd gear
		D ₄	: Drive range 4th gear
		O.D.	: Overdrive

HOW TO USE THIS MANUAL

8. The **UNITS** given in this manual are primarily expressed as SI UNITS (International System of Unit), and alternately expressed in the metric system and in the yard/pound system.

“Example”

Tightening torque:

59 - 78 N·m (6.0 - 8.0 kg-m, 43 - 58 ft-lb)

9. **TROUBLE DIAGNOSES** are included in sections dealing with complicated components.
10. **SERVICE DATA AND SPECIFICATIONS** are contained at the end of each section for quick reference of data.
11. The captions **WARNING** and **CAUTION** warn you of steps that must be followed to prevent personal injury and/or damage to some part of the vehicle.
- **WARNING** indicates the possibility of personal injury if instructions are not followed.
 - **CAUTION** indicates the possibility of component damage if instructions are not followed.
 - **BOLD TYPED STATEMENTS** except **WARNING** and **CAUTION** give you helpful information.

HOW TO READ WIRING DIAGRAMS

WIRING DIAGRAM

Symbols used in WIRING DIAGRAM are shown below:

Example

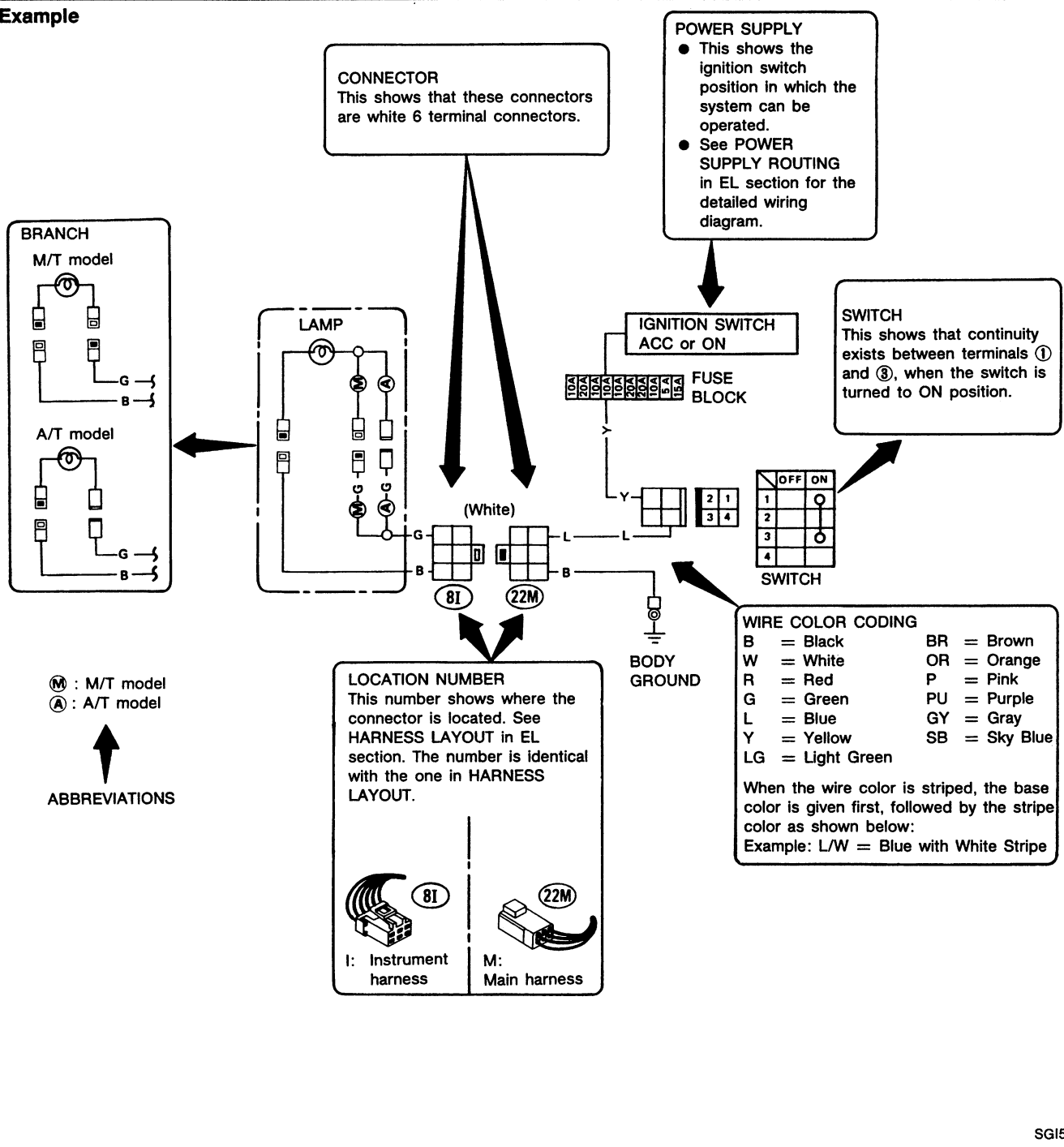

SGI543

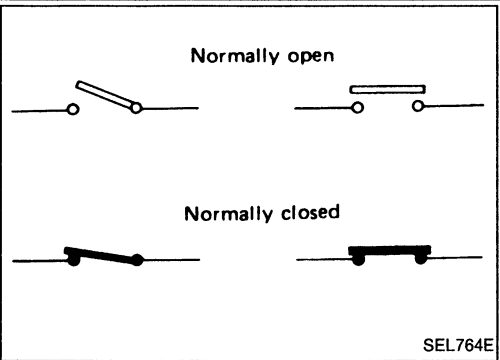

SWITCH POSITIONS

Wiring diagram switches are shown with the vehicle in the following condition.

- Ignition switch "OFF".
- Doors, hood and trunk lid/back door closed.
- Pedals are not depressed and parking brake is released.

GI
MA
EM
LC
EF & EC
FE
CL
MT
AT
FA
RA
BR
ST
BF
HA

HOW TO READ WIRING DIAGRAMS

Example

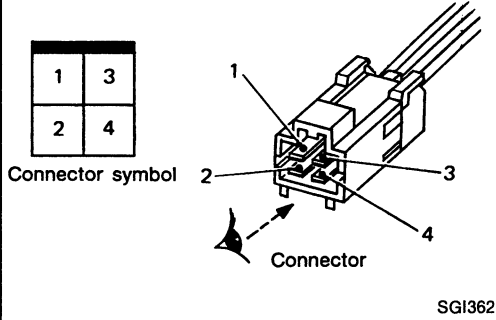

CONNECTOR SYMBOLS

- All connector symbols in wiring diagrams are shown from the terminal side.

Example

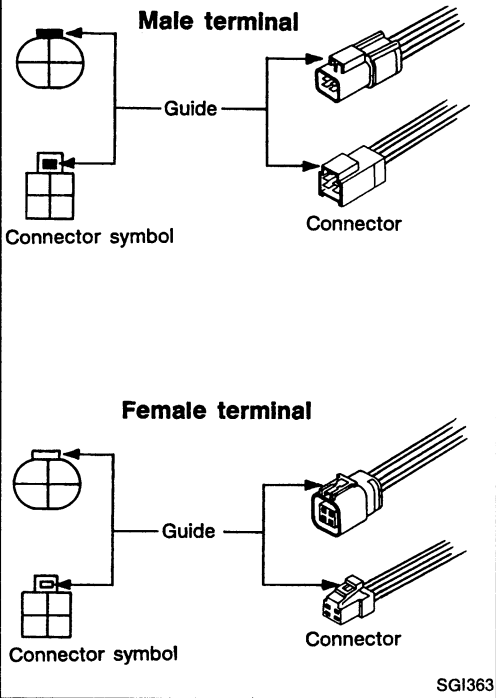

- Male and female terminals
Connector guides for male terminals are shown in black and female terminals in white in wiring diagrams.

MULTIPLE SWITCH

The continuity of the multiple switch is identified in the switch chart in wiring diagrams.

Example

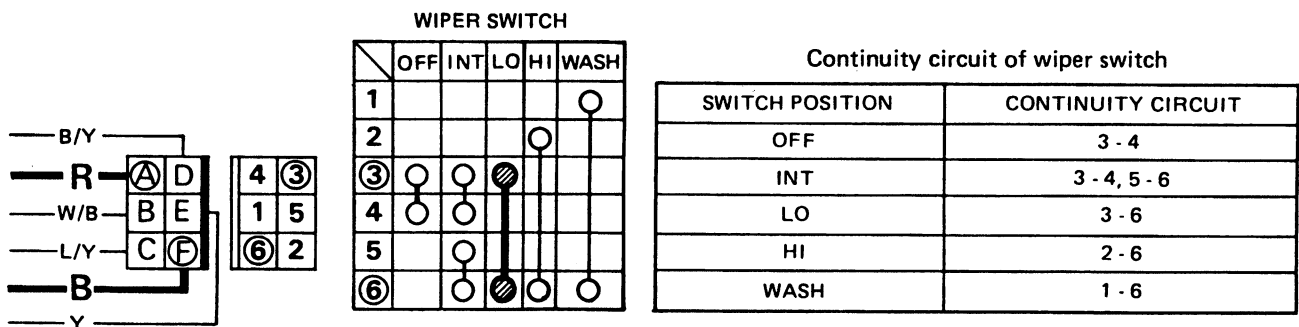

Example: Wiper switch in LO position

Continuity circuit: Red wire - (A) terminal - (3) terminal - Wiper switch (● - ● : LO) - (6) terminal - (F) terminal - Black wire

HOW TO READ WIRING DIAGRAMS

SUPER MULTIPLE JUNCTION (S.M.J.)

- The "S.M.J." indicated in wiring diagrams is shown in a simplified form. The terminal arrangement should therefore be referred to in the foldout at the end of the Service Manual.
- The foldout should be spread to read the entire wiring diagram.

GI

Example

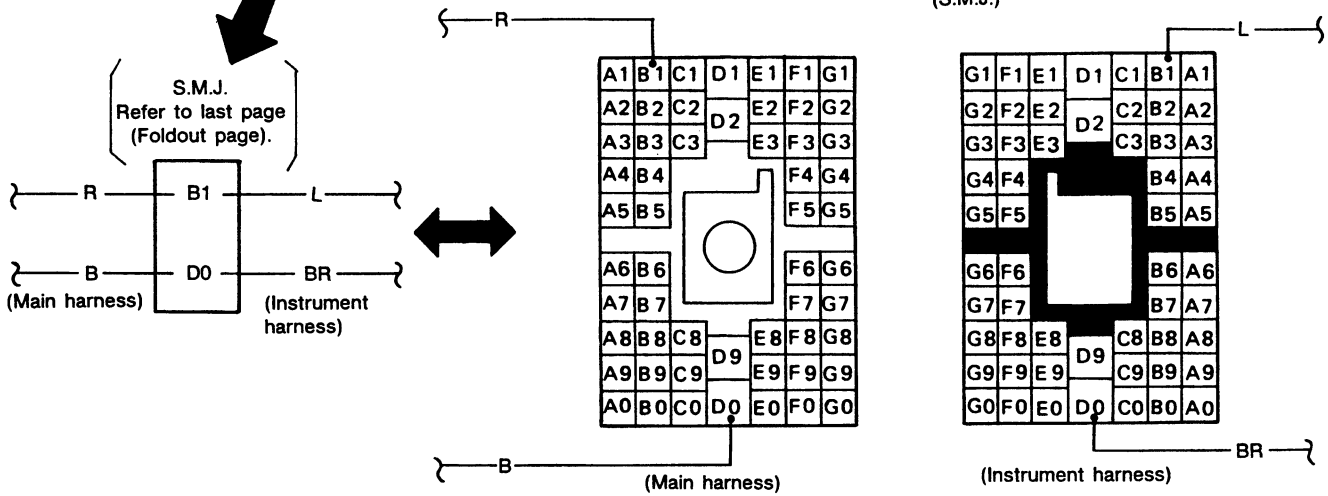
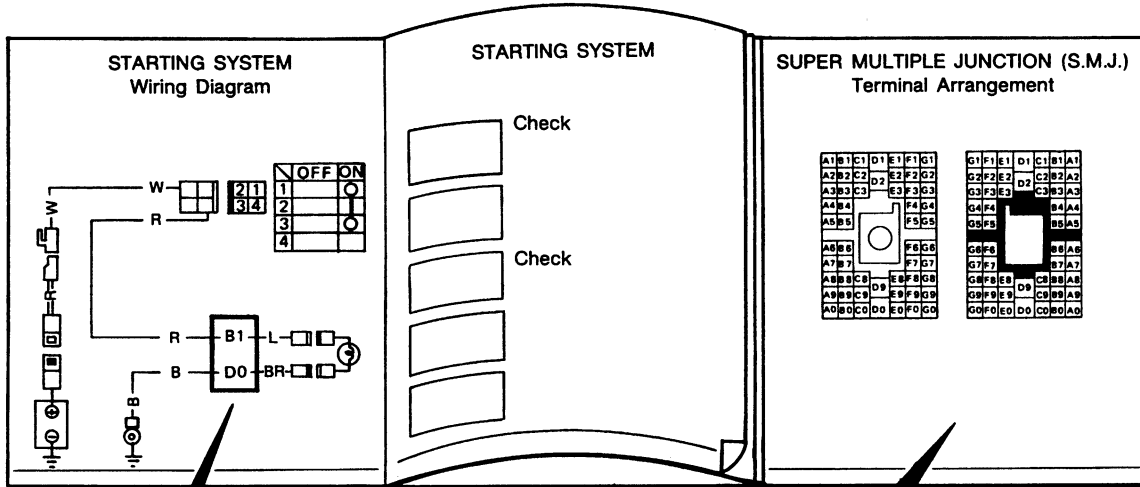

MA

EM

LC

EF &
EC

FE

CL

MT

AT

FA

RA

BR

ST

BF

HA

EL

SEL653F

HOW TO FOLLOW FLOW CHART IN TROUBLE DIAGNOSES

Example

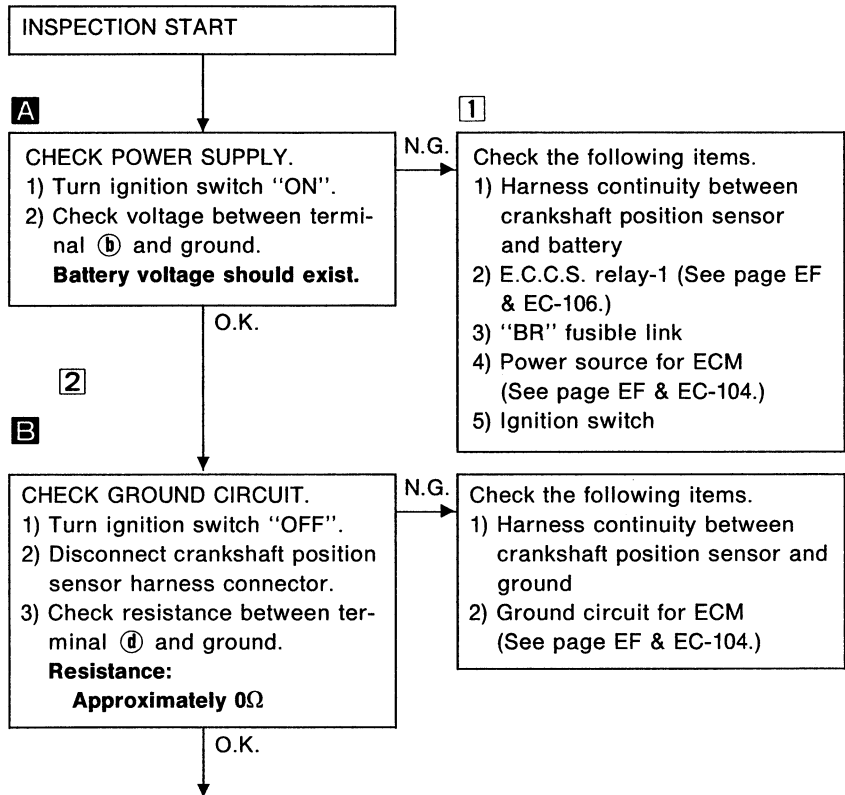
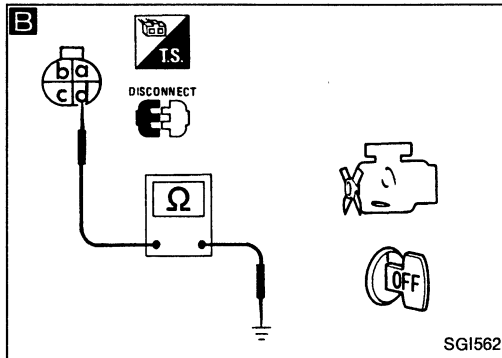
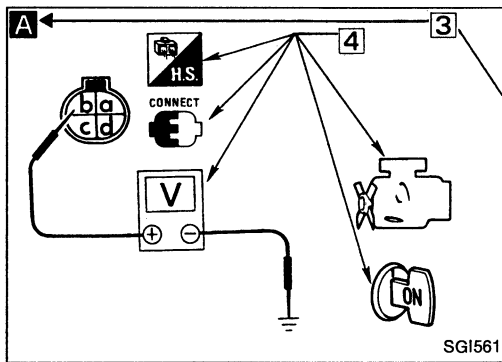

NOTICE

The flow chart indicates work procedures required to diagnose problems effectively. Observe the following instructions before diagnosing.

- 1) Use the flow chart after locating probable causes of a problem following the "Preliminary Check" or the "Symptom Chart".
- 2) After repairs, re-check that the problem has been completely eliminated.
- 3) Refer to Component Parts Location and Harness Layout for the Systems described in each section for identification/location of components and harness connectors.
- 4) Refer to the Circuit Diagram for Quick Pinpoint Check. If you must check circuit continuity between harness connectors in more detail, such as when a sub-harness is used, refer to Wiring Diagram and Harness Layout in EL section for identification of harness connectors.
- 5) When checking circuit continuity, ignition switch should be "OFF".
- 6) Before checking voltage at connectors, check battery voltage.
- 7) After accomplishing the Diagnostic Procedures and Electrical Components Inspection, make sure that all harness connectors are reconnected as they were.

HOW TO FOLLOW FLOW CHART IN TROUBLE DIAGNOSES

HOW TO FOLLOW THIS FLOW CHART

1 Work and diagnostic procedure

Start to diagnose a problem using procedures indicated in enclosed blocks, as shown in the following example.

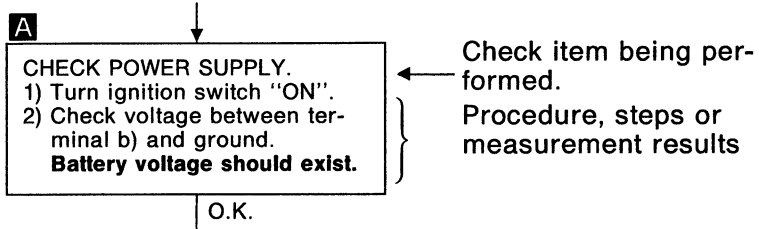

2 Measurement results

Required results are indicated in bold type in the corresponding block, as shown below:

These have the following meanings:

Battery voltage → 11 - 14V or approximately 12V

Voltage: Approximately 0V → Less than 1V

3 Cross reference of work symbols in the text and illustrations

Illustrations are provided as visual aids for work procedures. For example, symbol **A** indicated in the left upper portion of each illustration corresponds with the symbol in the flow chart for easy identification. More precisely, the procedure under the "CHECK POWER SUPPLY" outlined previously is indicated by an illustration **A**.

4 Symbols used in illustrations

Symbols included in illustrations refer to measurements or procedures. Before diagnosing a problem, familiarize yourself with each symbol.

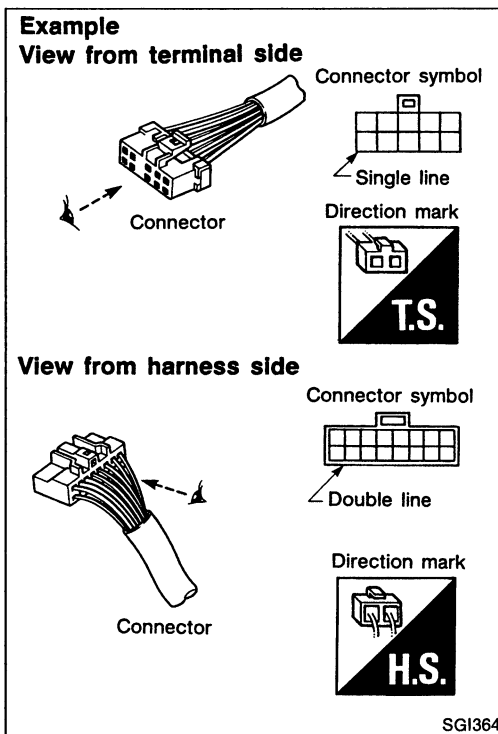

Direction mark

A direction mark is shown to clarify the side of connector (terminal side or harness side).

Direction marks are mainly used in the illustrations indicating terminal inspection.



: View from terminal side ... T.S.

- All connector symbols shown from the terminal side are enclosed by a single line.















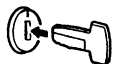





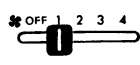

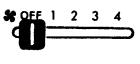









: View from harness side ... H.S.

- All connector symbols shown from the harness side are enclosed by a double line.

HOW TO FOLLOW FLOW CHART IN TROUBLE DIAGNOSES

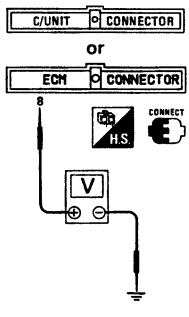
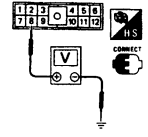
Key to symbols signifying measurements or procedures

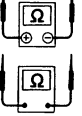
Symbol	Symbol explanation	Symbol	Symbol explanation
	Check after disconnecting the connector to be measured.		Current should be measured with an ammeter.
	Check after connecting the connector to be measured.		Procedure with CONSULT
	Insert key into ignition switch.		Procedure without CONSULT
	Remove key from ignition switch.		A/C switch is "OFF".
	Turn ignition switch to "OFF" position.		A/C switch is "ON".
	Turn ignition switch to "ON" position.		Fan switch is "ON". (At any position except for "OFF" position)
	Turn ignition switch to "START" position.		Fan switch is "OFF".
	Turn ignition switch from "OFF" to "ACC" position.		Apply battery voltage directly to components.
	Turn ignition switch from "ACC" to "OFF" position.		Drive vehicle.
	Turn ignition switch from "OFF" to "ON" position.		Disconnect battery negative cable.
	Turn ignition switch from "ON" to "OFF" position.		Depress brake pedal.
	Do not start engine, or check with engine stopped.		Release brake pedal.
	Start engine, or check with engine running.		Depress accelerator pedal.
	Apply parking brake.		Release accelerator pedal.
	Release parking brake.		<p>Pin terminal check for S.M.J. type ECM and A/T control unit connectors.</p> <p>For details regarding the terminal arrangement, refer to the foldout page.</p> 
	Check after engine is warmed up sufficiently.		
	Voltage should be measured with a voltmeter.		
	Circuit resistance should be measured with an ohmmeter.		

CONSULT CHECKING SYSTEM

Function and System Application

Diagnostic test mode	Function	E.C.C.S.
Work support	This mode enables a technician to adjust some devices faster and more accurately by following the indications on CONSULT.	X
Self-diagnostic results	Self-diagnostic results can be read and erased quickly.	X
Data monitor	Input/Output data in the ECM can be read.	X
Active test	Diagnostic Test Mode in which CONSULT drives some actuators apart from the ECMs and also shifts some parameters in a specified range.	X
ECM part number	ECM part number can be read.	X
Function test	E.C.C.S. faults can be isolated to a general area, semi-automatically and in a short time, by following the directions on the screen.	X

X: Applicable

Lithium Battery Replacement

CONSULT contains a lithium battery. When replacing the battery obey the following:

WARNING:

Replace the lithium battery with **SANYO Electric Co., Ltd., CR2032 only**. Use of another battery may present a risk of fire or explosion. The battery may present a fire or chemical burn hazard if mistreated. **Do not recharge, disassemble or dispose of in fire.**

Keep the battery out of reach of children and discard used battery conforming to the local regulations.

Checking Equipment

When ordering the below equipment, contact your INFINITI distributor.

Tool name	Description
NISSAN CONSULT kit ① CONSULT unit and accessories ② Program card (UE920)	

IDENTIFICATION INFORMATION

Model Variation

Body	Destination	Grade	Model	Engine	Transaxle
Sedan	Non-California	STD	BBYALGFP10EUA	SR20DE	RS5F32A
			BBYALGAP10EUA		RL4F03A
	California		BBYALGFP10EVA		RS5F32A
			BBYALGAP10EVA		RL4F03A
	Canada		BBYALGFP10ENA		RS5F32A
			BBYALGAP10ENA		RL4F03A

Prefix and suffix designations:

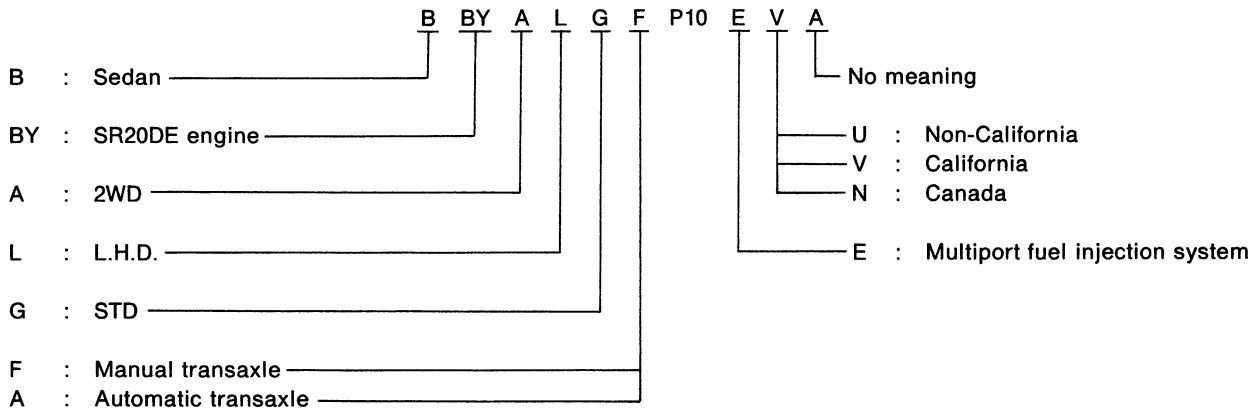

IDENTIFICATION INFORMATION

Identification Number

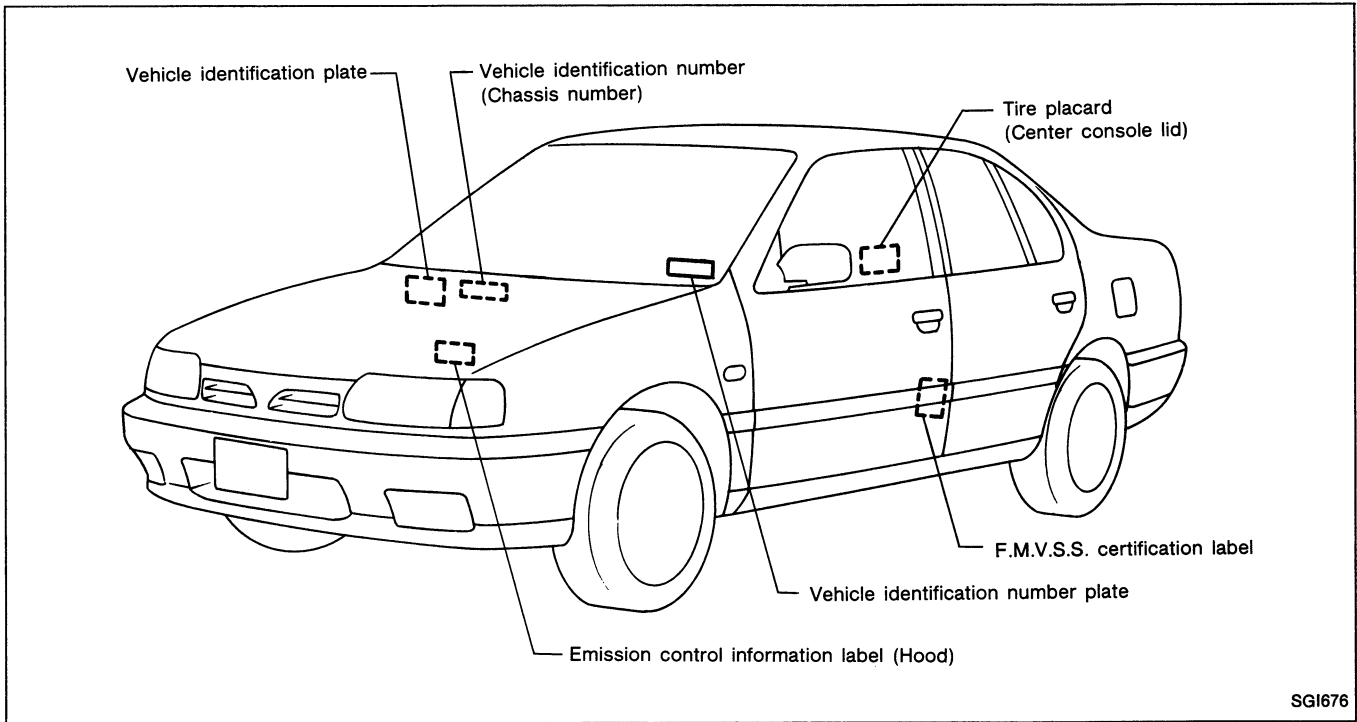

VEHICLE IDENTIFICATION NUMBER ARRANGEMENT

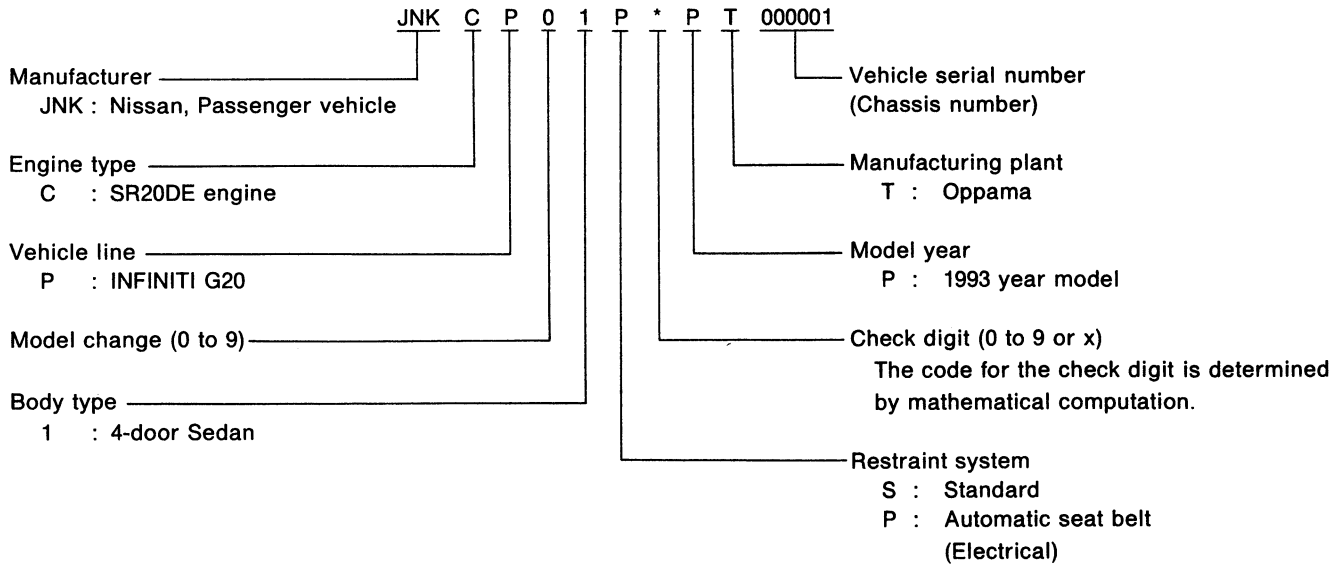

GI

MA

EM

LC

EF &
EC

FE

CL

MT

AT

FA

RA

BR

ST

BF

HA

EL

IDENTIFICATION INFORMATION

Identification Number (Cont'd)

IDENTIFICATION PLATE

NISSAN MOTOR CO., LTD. JAPAN			
型式	TYPE TIPO	△	
CHASSIS NO. NO. DE CHASIS		△	
MODEL MODELO		△	
○ カラー COLOR TRIM トリム COLOR GUARNICION		△ △	○
エン ENGINE ジン MOTOR		△ △	CC
ミッション TRANS. AXLE アックスル TRANS. EJE		△ △	
	工場	PLANT PLANTA	
日産自動車株式会社		MADE IN JAPAN	

- 1 Type
- 2 Vehicle identification number (Chassis number)
- 3 Model
- 4 Body color code
- 5 Trim color code
- 6 Engine model
- 7 Engine displacement
- 8 Transmission model
- 9 Axle model

SGI315

ENGINE SERIAL NUMBER

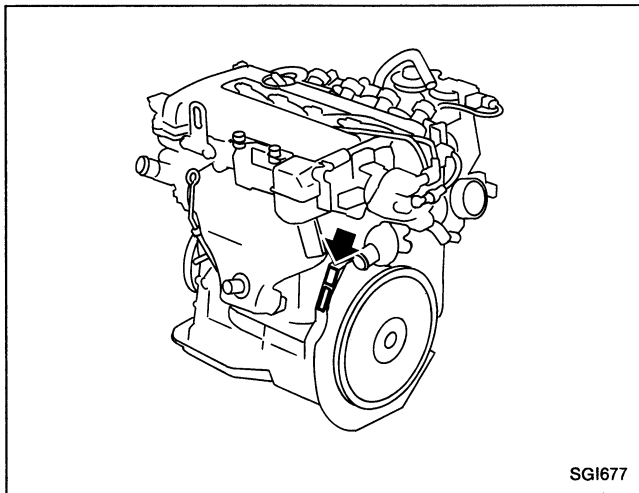

SGI677

MANUAL TRANSAXLE NUMBER

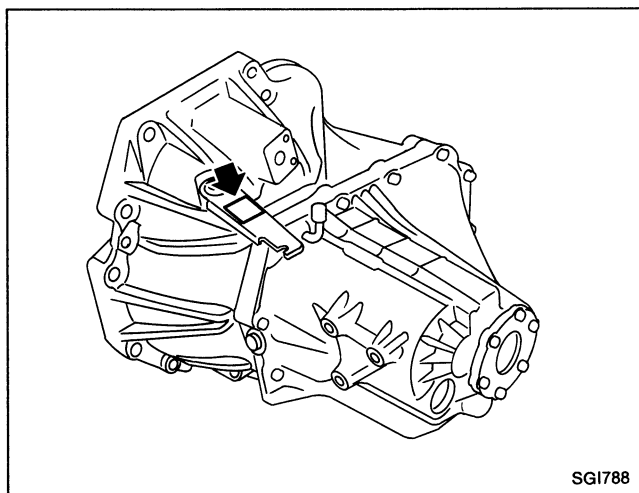

SGI788

AUTOMATIC TRANSAXLE NUMBER

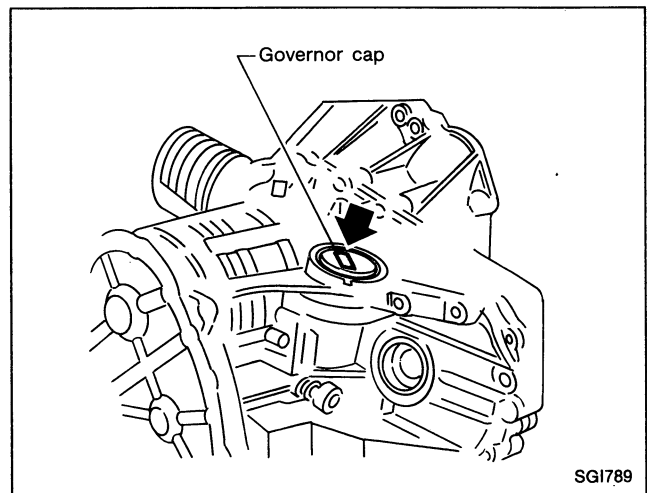

SGI789

IDENTIFICATION INFORMATION

Dimensions

Unit: mm (in)

Model		Sedan
Overall length		4,440 (174.8)
Overall width		1,694 (66.7)
Overall height		1,389 (54.7)
Wheel base		2,550 (100.4)
Tread	Front	1,471 (57.9)
	Rear	1,461 (57.5)

GI

MA

EM

LC

EF &
EC

FE

CL

Wheels and Tires

Road wheel	Aluminum	6-JJ x 14
	Offset mm (in)	45 (1.77)
Tire size	Conventional	195/60HR14
	Spare	T125/70D15

MT

AT

FA

RA

BR

ST

BF

HA

EL