

Y 104

95-W-2201

**NICHIBYU**  
**ELECTRIC LIFT TRUCKS**

# SERVICE MANUAL

60 SERIES  
FB10P-30P

WORKSHOP  
SERVICE DATA

**NICHIBYU**  
NIPPON YUSOKI CO.,LTD.  
KYOTO, JAPAN

## 0. GENERAL

<b>0-1 MODEL NAME AND NAME PLATE</b> .....	3
1. MODEL CODING SYSTEM .....	3
2. NAME PLATE .....	4
<b>0-2 POSITION OF SERIAL NUMBER ON     FRAME AND COMPONENTS</b> .....	4
<b>0-3 SPECIFICATIONS</b> .....	5
1. SPECIFICATIONS FOR STANDARD TRUCKS .....	5
2. SPECIFICATIONS FOR HIGH SPEED TRUCKS .....	6
<b>0-4 STABILITY OF FORKLIFT TRUCK</b> .....	7
1. Load center and load chart .....	7
<b>0-5 BEFORE STARTING TO WORK</b> .....	8

# 0. GENERAL

## 0-1 MODEL NAME AND NAME PLATE

### 1. MODEL CODING SYSTEM

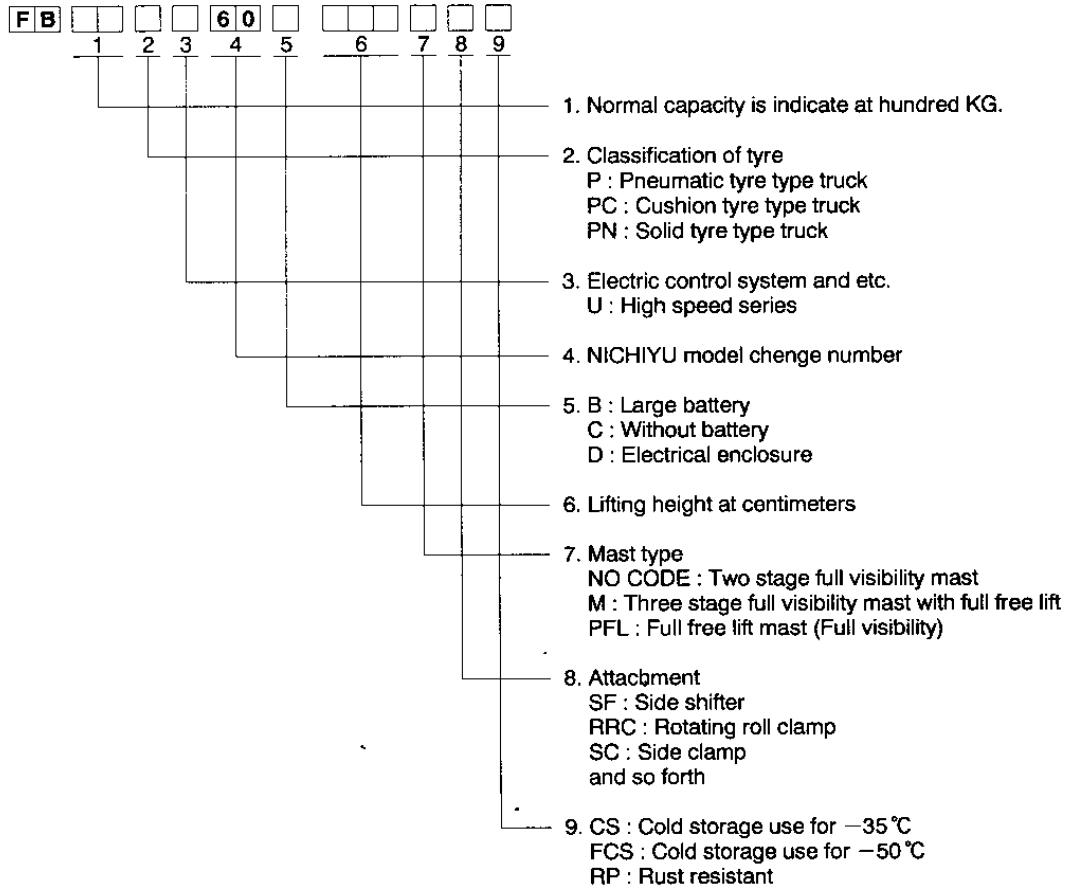

## 2. NAME PLATE

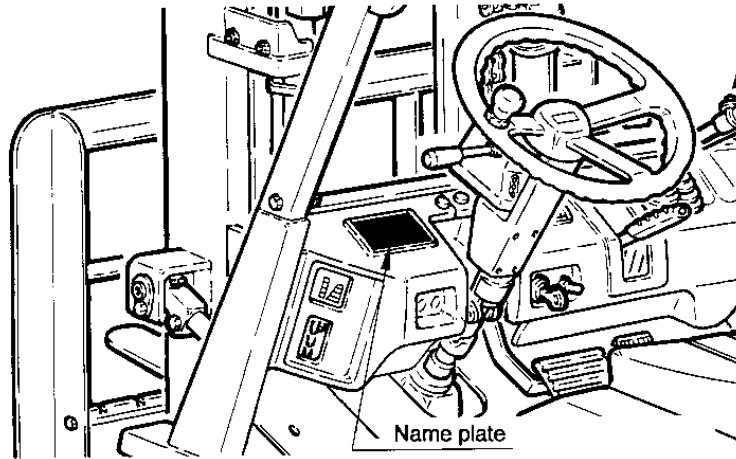
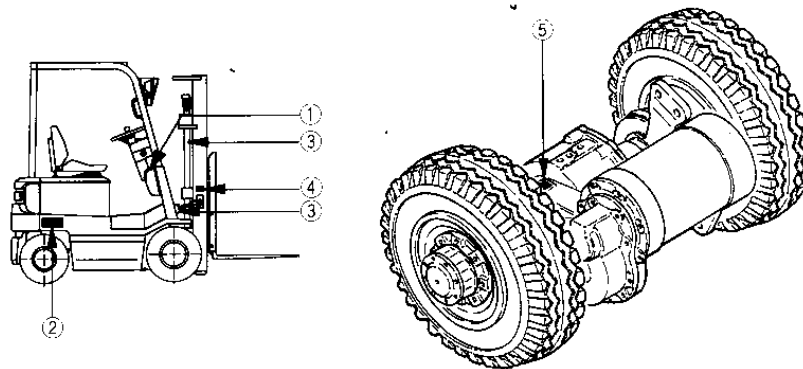

Fig. 0-1 Position of name plate

## 0-2 POSITION OF SERIAL NUMBER ON FRAME AND COMPONENTS



- ① Chasis serial No. (On name plate)
- ② Chasis serial No. (For licence plate)
- ③ Lift cylinder serial No.
- ④ Mast name plate
- ⑤ Drive ass'y No.

Fig. 0-2 Position of serial numbers

## 0-3 SPECIFICATIONS

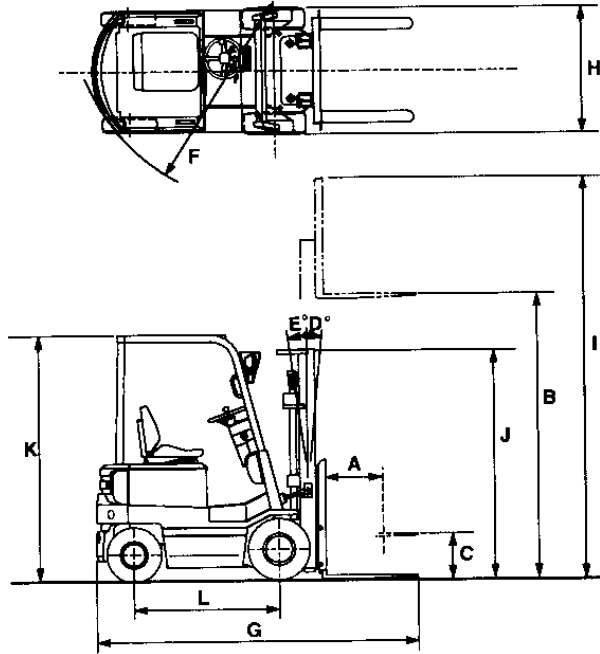

### 1. SPECIFICATIONS FOR STANDARD TRUCKS

MODELS		FB10P	FB14P	FB15P	FB18P	FB20P	FB25P	FB30P	
Capacity		1000 kg	1350 kg	1500 kg	1750 kg	2000 kg	2500 kg	3000 kg	
Load center	A	500 mm							
Lift height	B	3000 mm							
Free lift	C	390 mm							
Lift speed	Unloaded	540 mm/s				470 mm/s		410 mm/s	
	Loaded	350 mm/s	330 mm/s	320 mm/s	310 mm/s	280 mm/s	260 mm/s	240 mm/s	
Tilt angle	Forward	6°							
	Backward	12°							
Travel speed	Unloaded	15 km/h							
	Loaded	13 km/h			12.5 km/h	13 km/h	14.5 km/h		
Min. turning radius	F	1760 mm		1775 mm	1980 mm	2035 mm	2240 mm		
Overall length	G	2735 mm	2885 mm	2930 mm	3155 mm	3215 mm	3580 mm		
Overall width	H	1050 mm		1090 mm	1150 mm			1210 mm	
Overall height	Mast lifted	4000 mm							
	Mast lowered	1880 mm							
	Overhead guard	2110 mm (1995 mm)							
Wheelbase	L	1250 mm		1400 mm		1600 mm			
Tread	Front wheel	890 mm		900 mm		955 mm			
	Rear wheel	900 mm		945 mm		980 mm			
Road clearance		110 mm			235 mm				
Service weight		2635 kg	2850 kg	2950 kg	3180 kg	3750 kg	4255 kg	4730 kg	
Tyre	Front tyre	Single	8.00 - 9 - 10 PR		21 x 8 - 9 - 14 PR		23 x 9 - 10 - 16 PR		28 x 9 - 15 - 12 PR
		No puncture	8.00 - 9		21 x 8 - 9		23 x 9 - 10		28 x 9 - 15
		Cushion	21 x 6 x 15		21 x 7 x 15		22 x 8 x 16		28 x 10 x 22
	Rear tyre	Single	5.00 - 8 - 8 PR			18 x 7 - 8 - 14 PR		6.50 - 10 - 10 PR	
		No puncture	5.00 - 8			18 x 7 - 8		6.50 - 10	
		Cushion	18 x 5 x 12					22 x 6 x 16	
Control system		FET Chopper (Mi-con)							
Electric motors	For traction	7.8 kw				8.3 kw		10.0 kw	
	For hydraulic	7.7 kw				9.0 kw		12.0 kw	
	For power steering	0.4 kw				0.5 kw			
Storage battery	Standard	48V 390AH/5H		48V 400AH/5H		48V 450AH/5H	48V 565AH/5H	72V 450AH/5H	
Charger (Option)	(Option)	48V 400AH/5H		48V 485AH/5H		48V 545AH/5H	48V 600AH/5H	72V 485AH/5H	
Automatic stationary charger									

- Subject to change without notice for improvement.
- Figures shown in the above specification table and unit with two stage full visibility mast (STD).

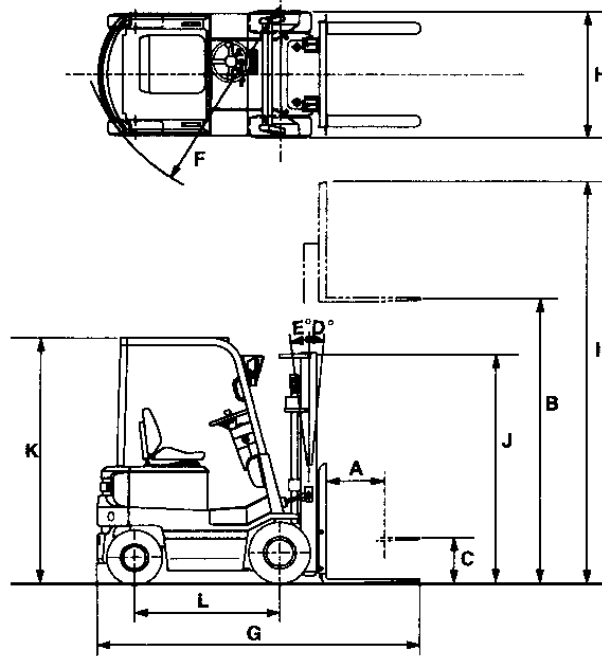

## 2. SPECIFICATIONS FOR HIGH SPEED TRUCKS

MODELS		FB10P	FB14P	FB15P	FB18P	FB20P	FB25P	
Capacity		1000 kg	1350 kg	1500 kg	√1750 kg	2000 kg	2500 kg	
Load center	A	500 mm						
Lift height	B	3000 mm						
Free lift	C	390 mm						
Lift speed	Unloaded	580 mm/s	570 mm/s		580 mm/s	550 mm/s		
	Loaded	400 mm/s	360 mm/s	350 mm/s	360 mm/s	340 mm/s	320 mm/s	
Tilt angle	Forward	6°						
	Forward	12°						
Travel speed	Unloaded	18 km/h			17.5 km/h		16.5 km/h	
	Loaded	15 km/h			15 km/h		14.5 km/h	
Min. turning radius	F	1760 mm		1775 mm		1980 mm	2035 mm	
Overall length	G	2735 mm	2885 mm		2830 mm	3155 mm	3215 mm	
Overall width	H	1050 mm		1090 mm		1150 mm		
Overall height	Mast lifted	4000 mm						
	Mast lowered	1980 mm						
	Overhead guard	2110 mm						
Wheelbase	L	1250 mm		1400 mm		1400 mm		
Tread	Front wheel	890 mm		900 mm		955 mm		
	Rear wheel	900 mm		900 mm		945 mm		
Road clearance		110 mm						
Service weight		2775 kg	2990 kg	3030 kg	3260 kg	3810 kg	4340 kg	
Tyre	Front tyre	Single	6.00 - 9 - 10 PR		21 × 8 - 9 - 14 PR		23 × 9 - 10 - 16 PR	
		No puncture	6.00 - 9		21 × 8 - 9		23 × 9 - 10	
		Cushion	21 × 6 × 15		21 × 7 × 15		22 × 8 × 16	
	Rear tyre	Single	5.00 - 8 - 8 PR		18 × 7 - 8 - 14 PR		18 × 7 - 8 - 14 PR	
		No puncture	5.00 - 8		18 × 7 - 8		18 × 7 - 8	
		Cushion			18 × 5 × 12			
Control system		FET chopper (Mi-con)						
Electric motors	For traction	9.0 kw				10.0 kw		
	For hydraulic	9.0 kw				10.0 kw		
	For power steering	0.4 kw				0.5 kw		
Storage battery	Standard	48V 400AH/5H		48V 485AH/5H		48V 545AH/5H	48V 600AH/5H	
	(Option)	48V 485AH/5H		48V 545AH/5H		48V 600AH/5H	-	
Charger (Option)		Automatic stationary charger						

- Subject to change without notice for improvement.
- Figures shown in the above specification table and unit with two stage full visibility mast (STD).

## 0-4 STABILITY OF FORKLIFT TRUCK

As shown in the figure, the counterbalanced forklift truck will balance on its drive wheel with a full rated capacity load on the forks. Consequently, careful attention should be paid to the load center so that truck does not unbalance. If a load should exceed the rated capacity of truck, or the rated load center, the rear steer tyres will lift off the ground and the possibility of toppling the truck exists.

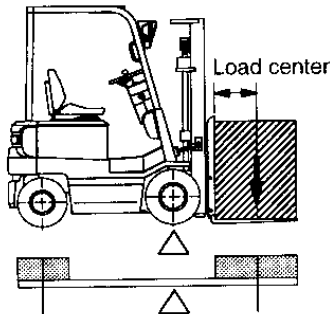

### 1. Load center and load chart

Distance from the center of gravity of a load on the forks to the surface of the forks is called load center. The CAPACITY CHART shows the relationship between load center and load capacity of the truck. Do not drag forks to the floor, lift up forks 150-200mm above floor when traveling with mast tilted backward fully.

When traveling, do not lifting and tilting forward. This could cause overturn by changing the center of gravity for the load.

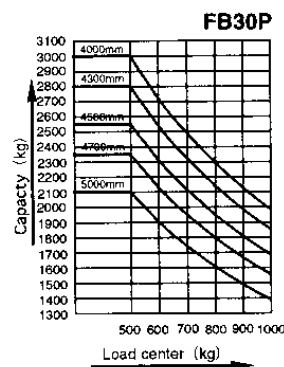
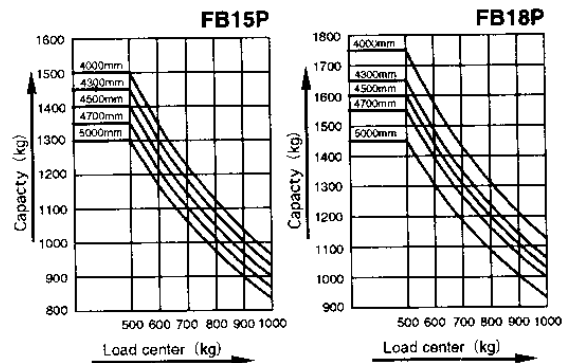
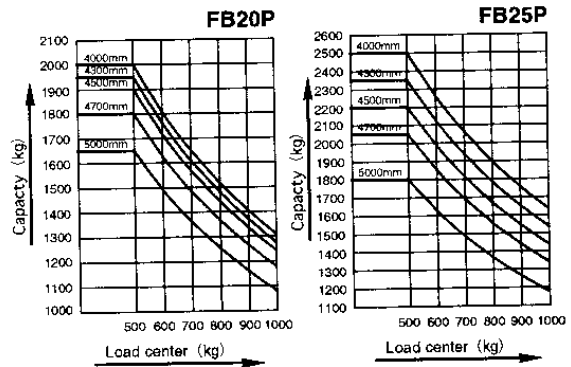
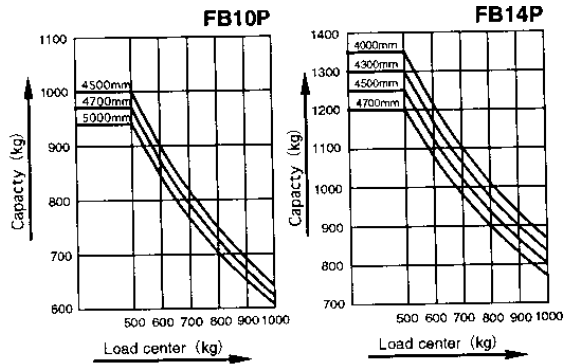
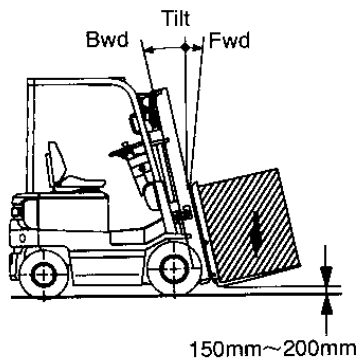

## 0-5 BEFORE STARTING TO WORK

### ▲ CAUTION

- When hoisting a truck or a heavy component, use ropes or cable with correct capacity.
- Do not use rope or cable which are kinked.
- After lifting or jacking up a truck, support it with safety blocks or rigid stands. Prevent tires from moving, with wedged blocks etc.
- When working under a truck, use a pit or proper safety precautions.
- When repairing electrics, be sure to disconnect the battery.
- When trouble-shooting with the battery connected, be sure to jack up the drive wheels.

#### (1) Tools and gauges

- a) Prepare tools, gauges (V-ohm meter, meggar meter, ampere meter, pressure gauge, torque wrench etc.) before starting to work.

#### (2) Proper arrangement

- a) Arrange and clean always a working place to work easily.
- b) Arrange disassembled parts well.

#### (3) Parts

- a) When replacing any parts, be sure to use NICHYU genuine parts.
- b) When replenishing battery electrolyte, be sure to use refined or distilled water.
- c) When disconnecting the lead wires, note the marks and connecting points.

#### (4) Repairing hydraulics

- a) When removing the hydraulic pipes, cap them to prevent dust from entering into the hydraulic components and pipes.
- b) When disassembling and assembling the hydraulic components, work at clean place and do not damage the parts.

#### (5) Inspection and maintenance

- a) Handle the truck and the parts carefully.
- b) Use a flaw detector or color check to check cracks.

#### (6) Tightening torque

- a) Observe tightening torque specified in this manual. If not specified, refer to the table "Tightening torque for bolts".
- b) All models are explained in this manual. See the items which mention for the correct model.  
STD: Standard type  
U : High speed type



## **8. MOTORS (DRIVE•HYDRAULIC•POWER•STEERING)**

<b>8-1 REMOVING</b> .....	109
1. Drive motor .....	109
2. Hydraulic motor .....	109
3. Power steering motor .....	109
<b>8-2 CONSTRUCTION AND CONSTRUCTIVE PARTS</b> .....	110
1. Drive motor .....	110
2. Hydraulic motor .....	110
<b>8-3 DISASSEMBLING PROCEDURES AND CAUTIONS</b> .....	111
1. Drive and hydraulic motor .....	111
2. Power steering motor .....	112
<b>8-4 INSPECTION</b> .....	113
1. Armature comp. ....	113
2. Carbon brush, brush holder and spring .....	114
3. Field coil .....	116
<b>8-5 ASSEMBLING PROCEDURES</b> .....	116
1. Mounting field coil and measuring insulation .....	116
2. Mounting brush holder .....	117
3. Tightening terminal bolt .....	117
4. Inspection of motor Ass'y .....	117
<b>8-6 TROUBLE SHOOTING</b> .....	118