

4. Wiring and control unit layout

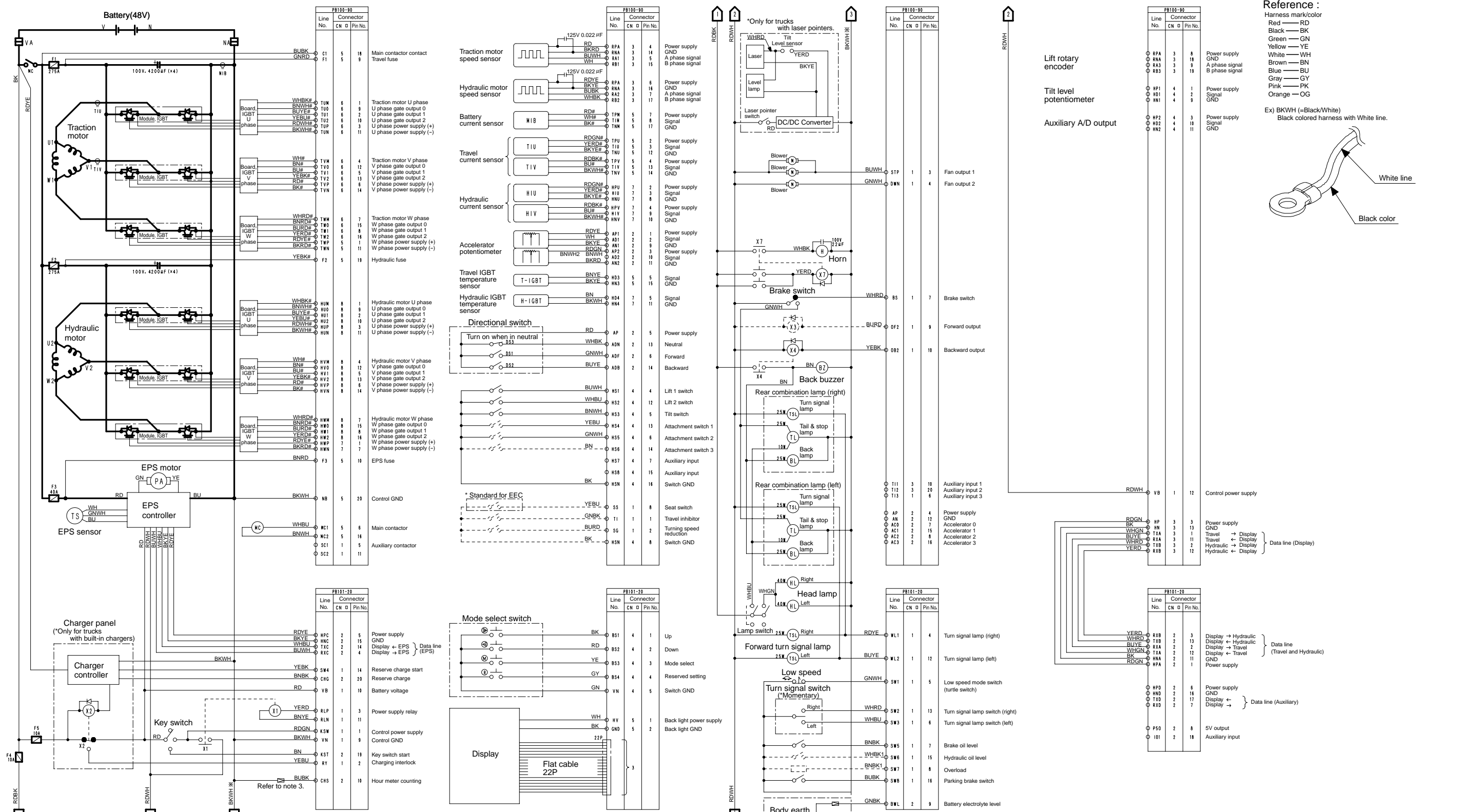

NOTE :
 1. Lead wires marked with # or * have different diameters.
 2. Broken lines indicate the use of optional equipment.
 3. Connect, and begin the hour meter countdown.

Reference :
 Harness mark/color
 Red — RD
 Black — BK
 Green — GN
 Yellow — YE
 White — WH
 Brown — BN
 Blue — BU
 Gray — GY
 Pink — PK
 Orange — OG

Ex) BKWH (=Black/White)
 Black colored harness with White line.

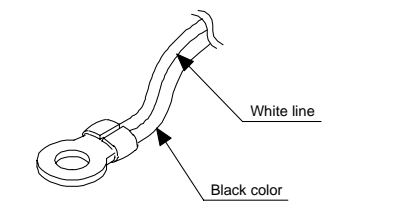

Line No.	Connector	Pin No.	Description
1	RD	1	Power supply
2	BK	2	GND
3	RD	3	A phase signal
4	BK	4	B phase signal
5	RD	5	Power supply
6	BK	6	GND
7	RD	7	U phase gate output 0
8	BK	8	U phase gate output 1
9	RD	9	U phase gate output 2
10	BK	10	U phase power supply (+)
11	RD	11	U phase power supply (-)

Line No.	Connector	Pin No.	Description
1	RD	1	Power supply
2	BK	2	GND
3	RD	3	U phase gate output 0
4	BK	4	U phase gate output 1
5	RD	5	U phase gate output 2
6	BK	6	U phase power supply (+)
7	RD	7	U phase power supply (-)
8	RD	8	Power supply
9	BK	9	GND
10	RD	10	Signal
11	BK	11	GND

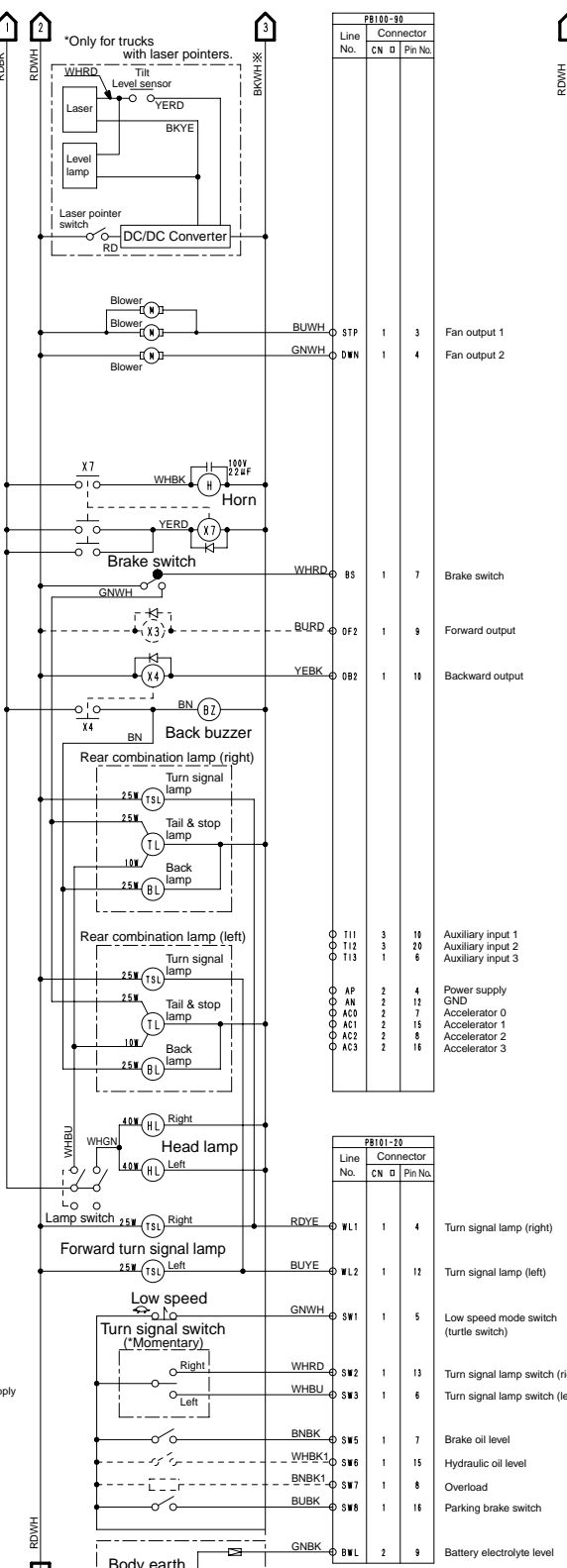

Line No.	Connector	Pin No.	Description
1	RD	1	Power supply
2	BK	2	GND
3	RD	3	A phase signal
4	BK	4	B phase signal
5	RD	5	Power supply
6	BK	6	GND
7	RD	7	U phase gate output 0
8	BK	8	U phase gate output 1
9	RD	9	U phase gate output 2
10	BK	10	U phase power supply (+)
11	RD	11	U phase power supply (-)

This is the cut pages sample. Download all 23 page(s) at: ManualPlace.com

Full download: <http://manualplace.com/download/nichiyu-forklift-fb-70-wiring-and-control-unit-layout/>

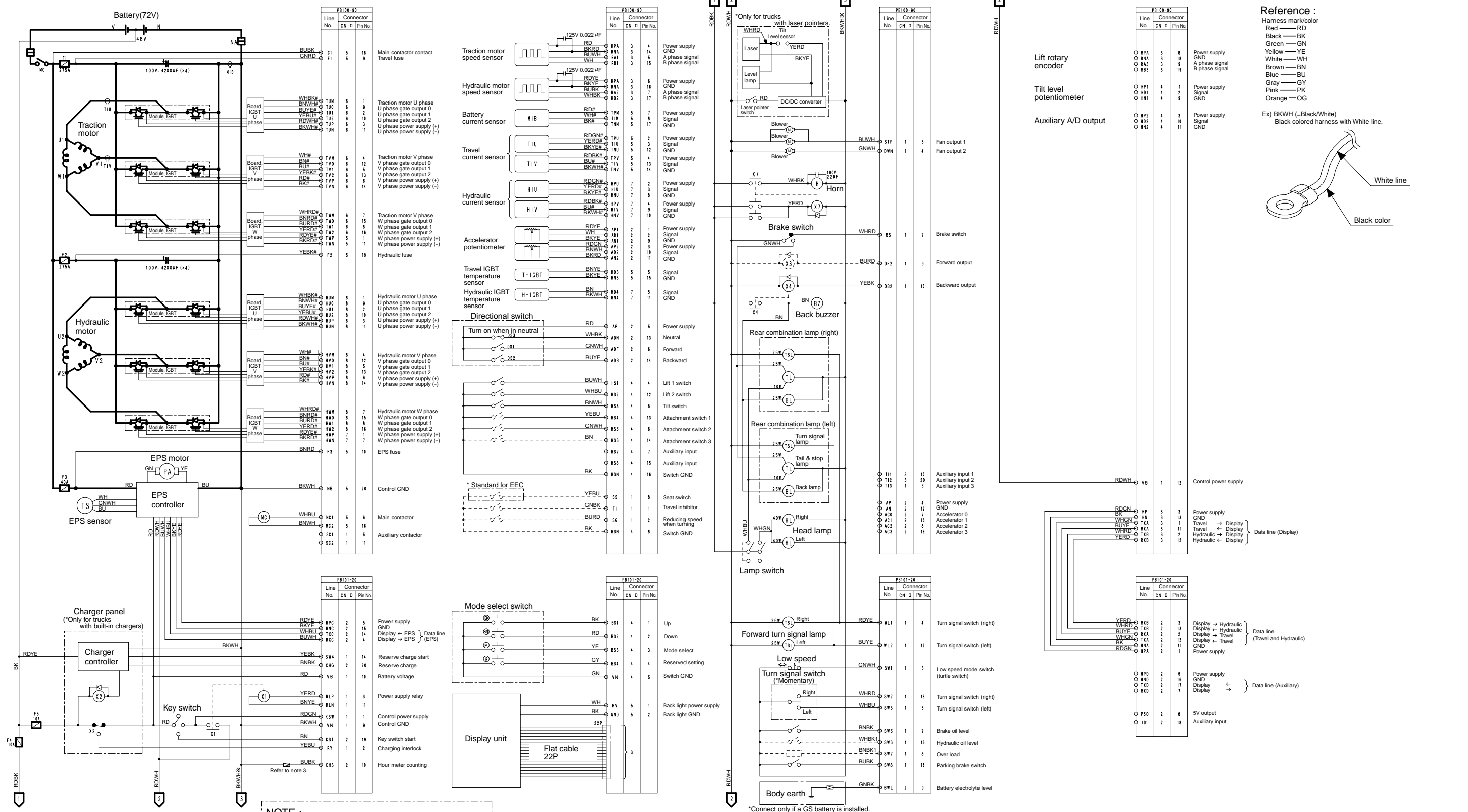

Reference :

Harness mark/color	
Red	— RD
Black	— BK
Green	— GN
Yellow	— YE
White	— WH
Brown	— BN
Blue	— BU
Gray	— GY
Pink	— PK
Orange	— OG

Ex) BKWH (=Black/White)
Black colored harness with White line.

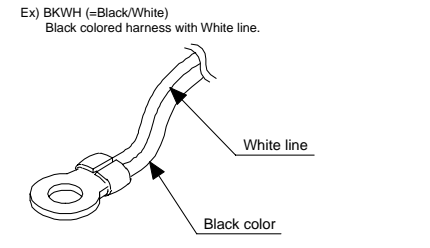

NOTE :

1. Lead wires marked with # or * have different diameters.
2. Broken lines indicate the use of optional equipment.
3. Connect, and begin the hour meter countdown.