

FB-60 SERIES

SICOS 60

FB10-30P

NICHIYU

NIPPON YUSOKI CO., LTD.

KYOTO, JAPAN

CONTENTS

1. Outlines and features	1
1. Improvement of safety and reliability	1
2. Improvement of operability	2
3. Others (for microcomputer)	2
2. Layout of electric components	3
3. Major new functions	4
4. Adjustment of SICOS 60	7
1. Adjustments and verification	7
2. Setting and adjustment	7
3. Adjustment of potentiometer	13
4. Setting of rotary switches	16
5. Practical trouble shooting (How to find the cause of problem)	20
1. Before starting	20
2. Attention for the troubleshooting	30
3. Procedure of troubleshooting	30
4. Analysis of fault cause	31
6. Outline of microcomputer controlled EPS	47
1. Outline of EPS system	47
2. Operation	48
3. Features	48
4. Self-diagnosis	49
7. Wiring and layout of control unit	55
● System wiring 48V (FB10P-25P-60)	55
● System wiring 72V (FB30P-60)	56
● Chassis wiring 48V (FB10P-18P-60)	57
● Chassis wiring 48V (FB20P/25P-60)	58
● Chassis wiring 72V (FB30P-60)	59
● Chassis wiring 48V (FB10P-18P-U60)	60
● Chassis wiring 48V (FB20P/25P-U60)	61
● Wiring in control unit 48V (FB10P-18P-60)	62
● Wiring in control unit 48V (FB20P/25P-60)	63
● Wiring in control unit 72V (FB30P-60)	64
● Wiring in control unit 48V (FB10P-18P-U60)	64
● Wiring in control unit 48V (FB20P/25P-U60)	65
● Chassis harness 48V (FB10P-25P-60)	67
● Chassis harness 72V (FB30P-60)	68
● Control unit harness 48V (FB10P-18P-60)	69
● Control unit harness 48V (FB20P/25P-60)	70
● Control unit harness 72V (FB30P-60)	71
● Control unit Ass'y (FB10P-18P-60)	72
● Control unit Ass'y (FB20P-30P-60)	73

1: Outlines and features

original (f)

1. Improvement of safety and reliability

- (1) Smooth start for lifting and tilting
..... Hydraulic chopper and SICOS 60.
- (2) Variable steering response for travel speed
..... Adoption of speed sensitive EPS.
- (3) Smooth braking
..... Adoption of regenerative brake for traveling and foot-braking. (Option)
- (4) Operator protection against battery when tipping truck over
..... Adoption of battery lock system.
- (5) Travel speed display
..... Display of actual travel speed and preset low speed.
- (6) Speed regulation for descending
..... Regulate descending speed at preset speed plus 1 km/h.
- (7) Display of total travel distance
- (8) Automatic lift speed regulation for travel speed
- (9) Self diagnosis function with click warning buzzer

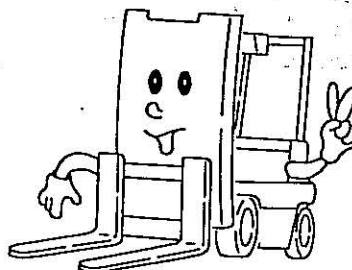

SICOS 60

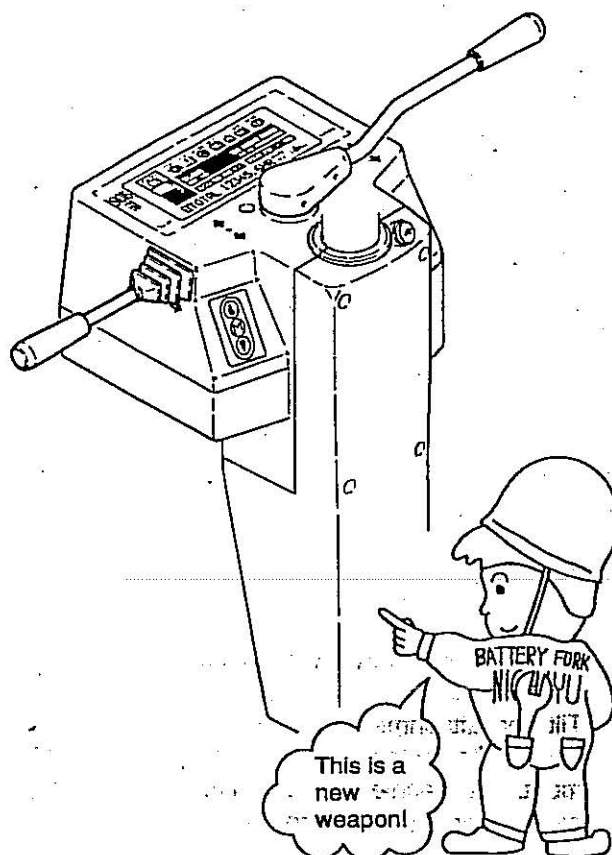

2. Improvement of operability

- (1) Improvement of maneuverability
 Compact chassis with powerful motor.
- (2) Selectable travel speed
 Selectable at eight (8) steps for the regulated travel speed. (Mode selection)
- (3) Selectable acceleration power
 Selectable at three (3) steps for acceleration power.
- (4) Selectable accelerator feeling
 Selectable at three (3) steps for accelerator feeling.
- (5) AOS (Option).....
 Automatic lift stop.
 Automatic fork level adjustment
 Finger tip control
 Shockless lift start and stop
- (6) Hour meter indication
 Total operated hour meter
 Travel hour meter
 Hydraulic hour meter
- (7) Large sized head lights
 Improvement of brightness (average 1.3 times, maximum 2 times)
 Automatic lighting system by photo sensor. (option)
 Halogen lights (option)

3. Others (for microcomputer)

- (1) Self diagnosis function (approx. 40 items for chopper abnormality, contactor abnormality, by-pass contactor abnormality, fuse defect, etc.) and I/O check function (approx. 90 items for motor current, plugging current, FET gate, switch, lamp, contactor, etc.) improve the inspectability by LCD panel indications.
 The error history memory function (approx. 31 items) is also equipped.
- (2) Lift speed is controlled by chopping and fully-turn-on functions of the chopper unit.
 Tilt and attachment speed are adjustable properly by the rotary switch for the duty adjustment. It achieves to improve inching performance, save energy and low noise.
- (3) The turn on and off timing of the travel and hydraulic contactors are controlled properly to prevent from arcing, and help to extend the lifetime of the contact tips.

Total operated hour meter

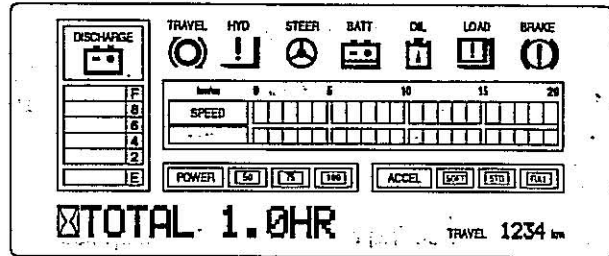

Travel hour meter

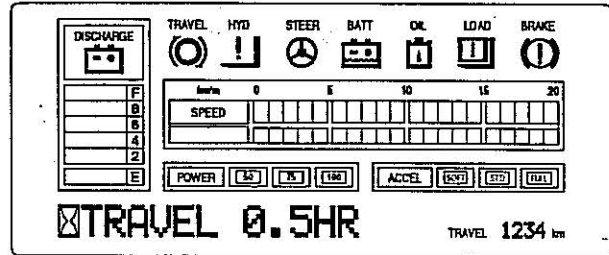

Hydraulic hour meter

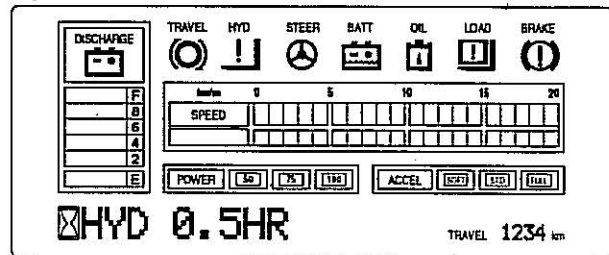

2. Layout of electric components

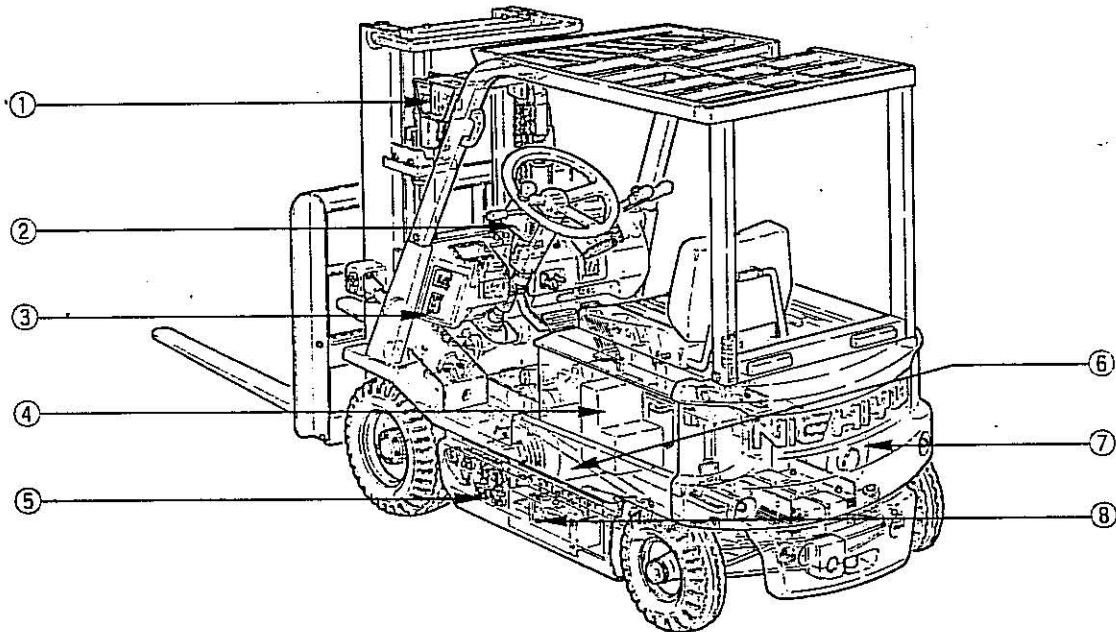

- ① Chopper unit (SICOS 60)
- ② Contactor
- ③ Control panel
(Large display, Mode setting switch)

- ④ Head light
- ⑤ Traction motor
- ⑥ Hydraulic motor
- ⑦ EPS controller

3. Major new functions

FB-60 series lift truck has equipped many new functions.

Major items of them are explained as follows.

(1) Large display with back light

Back light is equipped to read easily even in a dark area.

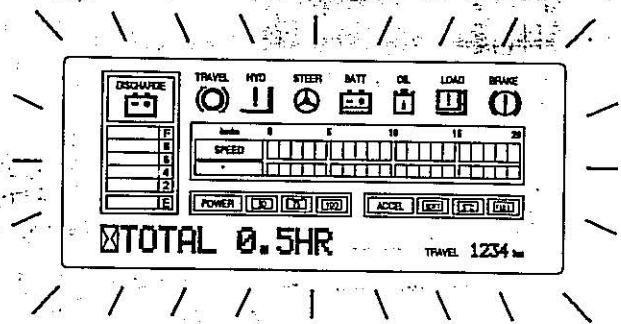

Contents of LCD

- ① Battery discharge indicator
- ② Safety monitor symbols
- ③ Travel speed
- ④ Selected low speed
- ⑤ Selected power
- ⑥ Selected accelerator feeling
- ⑦ Hour meter (Malfunction message display)
- ⑧ Servicing (Spanner) mark
- ⑨ Travel distance display (odometer)

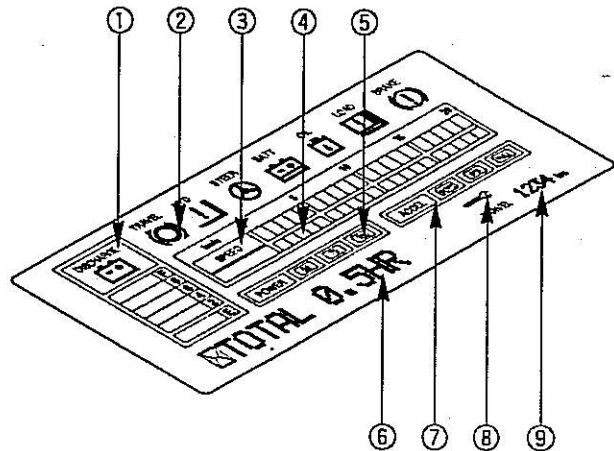

(2) Travel / hydraulic independent hour meter display

The hour meter displays the total operating time of traveling and hydraulic normally.

- ① When the up button is pushed, meter displays the travel hours only.

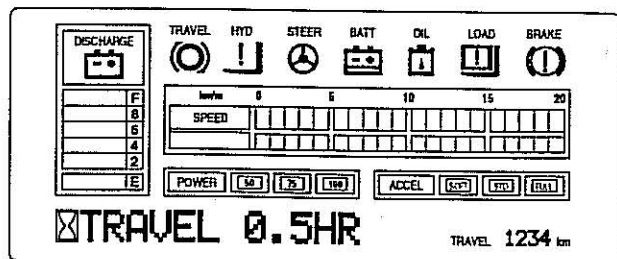
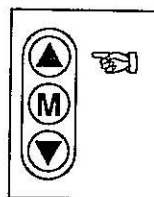

- ② When the down button is pushed, meter displays the hydraulic hours only.
This function helps to judge the lifetime of travel and hydraulic parts.

CAUTION

When pushing both of up and down buttons for more than three (3) seconds, the selected modes are returned to the initialized (factory default) settings.

Note this initialize function when the mode setting was changed.

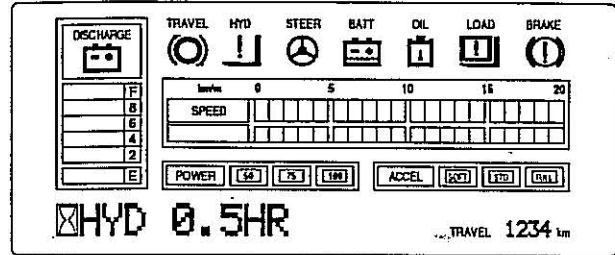
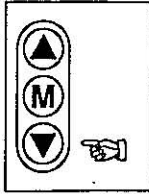

- (3) **Lever angle proportioned lift speed control**
Lift function had two speed (slow and high) on the previous model.
The new model has the potentiometer for the lift function. The lift speed is proportioned to the angle of the lift lever.

- (4) **Standardized speedometer**
The traveling speed is displayed in the center of the LCD by the bar segments.
This function is realized by the installation of the speed sensor on the differential case.

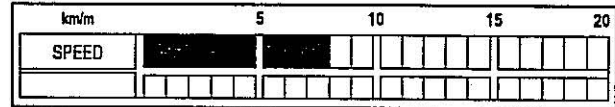

- (5) **Speed sensitive EPS**
Microcomputerized EPS controller is standardized. (except FB30P)
This controller controls the appropriate steering response for the traveling speed.
It also has the error history memory and fail-safe functions. These functions can be recalled its memories or grouped the problems under five (5) classifications to stop or recover the operation automatically when the problem is occurred.
(Previous 72V controller is used for FB30P)

- (6) **Warning buzzer for error message display**
When the error message is displayed on the LCD by the judgement of the SICOS-60, the buzzer which is equipped in the indicator panel is beeped to warn the operator. Beeping is quit automatically when the error is reset.

