



CNH America LLC, Racine, WI 53404 U.S.A.
Printed in U.S.A.

NEW HOLLAND
T9010
T9020
T9030
T9040
T9050
T9060

87562838 8/06
Replaces 87399833

OPERATOR'S MANUAL

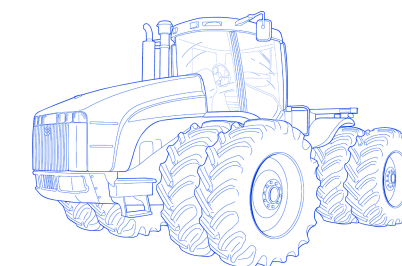

TABLE OF CONTENTS

1-TO THE OWNER	1
PRODUCT IDENTIFICATION AND SERIAL NUMBERS	3
CHEMICAL TANK MOUNTING	7
BUSINESS BAND RADIO READY (IF EQUIPPED)	8
2-SAFETY/DECALS	11
PERSONAL SAFETY ALERT	11
SAFETY	12
INSTRUCTIONAL SEAT SAFETY	15
MAINTENANCE SAFETY	16
FIRE SAFETY	16
BATTERY SAFETY	17
MACHINE OPERATION AND ROLL-OVER SAFETY	17
HAZARDOUS CHEMICALS	18
SAFETY DECALS	19
ROLL OVER PROTECTIVE STRUCTURE (ROPS)	25
SEAT BELTS	27
TRACTOR WARNING LAMPS AND SMV SYMBOL	28
IMPLEMENT WARNING LAMPS AND SMV SYMBOL	29
SAFETY CHAIN	29
3-OPERATING CONTROLS	31
TRACTOR ACCESS	31
OPERATOR'S SEAT WITH AIR SUSPENSION	33
STEERING COLUMN CONTROLS	37
STEERING COLUMN ADJUSTMENT	38
FOOT PEDALS	39
CENTER CONSOLE CONTROLS	40
RH ARMREST CONTROL CONSOLE	42
REMOTE VALVE FUNCTION CONTROL	45
ARM REST CONTROL CONSOLE ADJUSTMENT (IF EQUIPPED)	51
UPPER CONSOLE CONTROLS	51
HVAC CONTROL SYSTEM	55
AUTOMATIC TEMPERATURE CONTROL OPERATION	58
4-INSTRUMENTATION	63
ROPS POST INSTRUMENT CLUSTER	63
PROGRAMMING THE DISPLAY MONITOR	68
CHANGING U.S. STANDARD OR METRIC DISPLAY UNITS	68
CHANGING TIRE RADIUS	69
TIRE AVERAGE ROLLING RADIUS CHART	70
DYNAMIC ROLLING RADIUS	70
RADAR SENSOR CALIBRATION	71
RADAR CALIBRATION PROCEDURE	71
OLD HOURS	72
OPERATOR ADJUSTED MENU PROGRAM	73
WARNING FAULT DISPLAYS	77
CRITICAL WARNING DISPLAYS - LEVEL 1 - STANDARD AND PERFORMANCE	77
NON-CRITICAL DISPLAYS - LEVEL 2 - STANDARD AND PERFORMANCE	78
5-OPERATING INSTRUCTIONS	95
BEFORE STARTING THE ENGINE	95
SEAT BELTS	96
NORMAL ENGINE STARTING PROCEDURE	97
STOPPING THE ENGINE	99
COLD TEMPERATURE OPERATION	100
TOWING THE TRACTOR	104
TRANSPORTING THE TRACTOR	105
POWERSHIFT TRANSMISSION OPERATION	106

AUTOSHIFT OPERATION	110
24-SPEED TRANSMISSION OPERATION (IF EQUIPPED)	114
DIFFERENTIAL LOCK	116
CONSTANT ENGINE SPEED OPERATION (IF EQUIPPED)	117
6-FIELD OPERATION	119
OPERATING THE POWER TAKEOFF (PTO)	121
STANDARD DRAWBAR	123
THREE POINT HITCH PREPARATION	128
HITCH COUPLER - CATEGORY III OR IV-N	133
HITCH OPERATION	137
REMOTE HYDRAULICS	148
AUXILIARY IMPLEMENT POWER CONNECTIONS	159
7-IN FIELD PERFORMANCE	163
TRACTOR BALLAST	163
FRONT AND REAR SUITCASE WEIGHTS	169
FRONT SUITCASE WEIGHT, TIE BOLT AND CLAMP INSTALLATION	170
WHEEL WEIGHTS	172
WHEEL WEIGHT BOLT TORQUE	172
TIRE AND RIM SERVICE	173
TIRE PRESSURE FOR MAXIMUM TIRE LOAD AT RATED INFLATION	176
WHEEL BOLT TORQUES	180
WHEEL OFFSET DIRECTION CHANGE	180
SCRAPER OPERATING PROCEDURES	191
8-LUBRICATION/FILTERS/FLUIDS/MAINTENANCE	193
LUBRICATION AND MAINTENANCE	193
PLASTIC AND RESIN PARTS	193
LUBRICANTS AND CAPACITIES	193
ENGINE LUBRICATION	194
GRILLE AND HOOD ACCESS	197
ACCESS TO BATTERIES AND HYDRAULIC FILTER	199
LUBRICATION AND MAINTENANCE CHART	200
AIR INDUCTION SYSTEM	224
PRESSURE COOLING SYSTEM	245
SCA SERVICE REQUIREMENTS	245
9-ELECTRICAL SYSTEM	247
SPECIFICATIONS	247
GENERAL SERVICE INFORMATION	253
GENERAL SPECIFICATIONS	255
10-SPECIFICATIONS	255
TRACTOR WEIGHTS	258
APPROXIMATE TRAVEL SPEEDS (MPH)	259
APPROXIMATE TRAVEL SPEEDS (KPH)	260
APPROXIMATE OVERALL MEASUREMENTS	266
DETAIL INDEX	267
DELIVERY REPORT	273
FIRST 50-HOUR SERVICE	277

GENERAL INFORMATION

INTRODUCTION TO THIS MANUAL

This manual contains important information about the safe operation, adjustment and routine maintenance of your New Holland T9000 Series Tractors. The manual is divided into ten sections as outlined in the General Table of Contents Page(s). Refer to the Detail Index at the end of this manual for locating specific items about your tractor.

Use this manual as a guide. Your tractor will remain a reliable working machine as long as it is kept in good working condition and serviced properly.

Read this manual before you start the engine or operate this tractor. If any information in this manual is not understood, or if you need more information or assistance, contact your dealer.

All persons training to operate, or who will be operating this tractor, should be old enough to possess a valid local vehicle operating permit (or other applicable local age requirement) and must have demonstrated the ability to operate and service the tractor correctly and safely.

If your tractor requires replacement parts, do not use unauthorized parts or substitute materials. New Holland dealers stock approved service parts and have technicians with special training that know the best methods of repair and maintenance for your tractor.

STATEMENT OF TRACTOR INTENDED USE

The New Holland T9000 Series Tractor, with standard equipment and authorized attachments, is intended to be used for customary farming, land leveling and related agriculture operations.

Installation of utility (dozer) blades, tile plows, front loaders or push bars on the tractor is not recommended. Any tractor damage resulting from the installation and/or use of such equipment is not covered by the tractor warranty.

OPERATOR MANUAL STORAGE COMPARTMENT

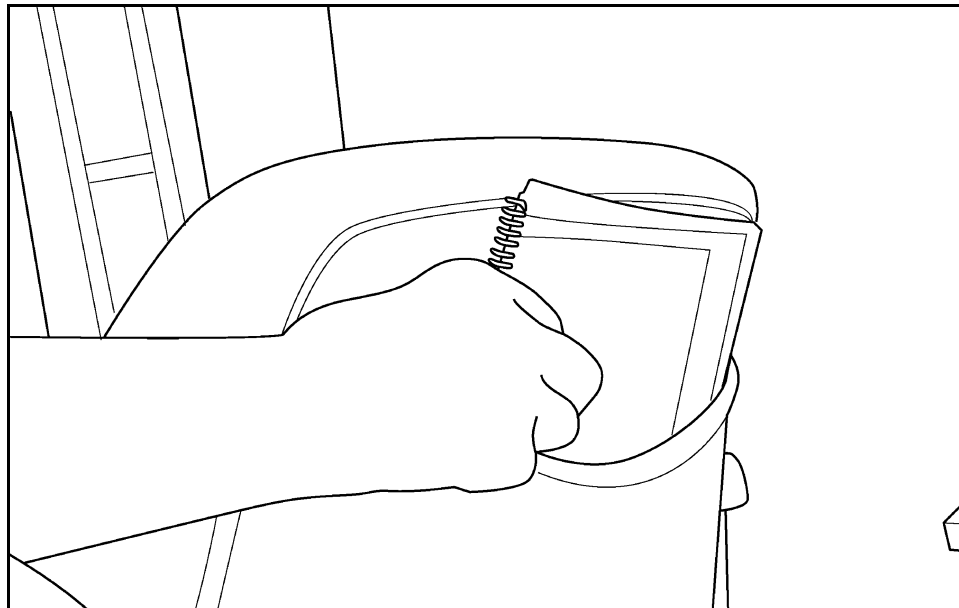

MK99H025

DO NOT permit anyone to operate or service this tractor until you or other operators have read this manual. The Operators Manual is a part of your tractor and must be available to all operators.

Make sure the manual is complete and in good condition. Store the Operators Manual and other important tractor information in the storage compartment provided on the rear side of the seat backrest.

TRACTOR ORIENTATION

The T9000 Series New Holland Tractor is classified as a four-wheel drive articulating vehicle. The standard tractor consists of front and rear frame assemblies that steer by pivoting at the center articulation joint (1).

The standard tractor front frame (2) incorporates the engine, front axle, transmission and cab. The rear frame (3) incorporates the rear axle and fuel tank.

The right hand (RH) (4) and left hand (LH) (5) side of the tractor as used in this manual are the same as your right hand and left hand when sitting in the operators seat looking forward over the engine.

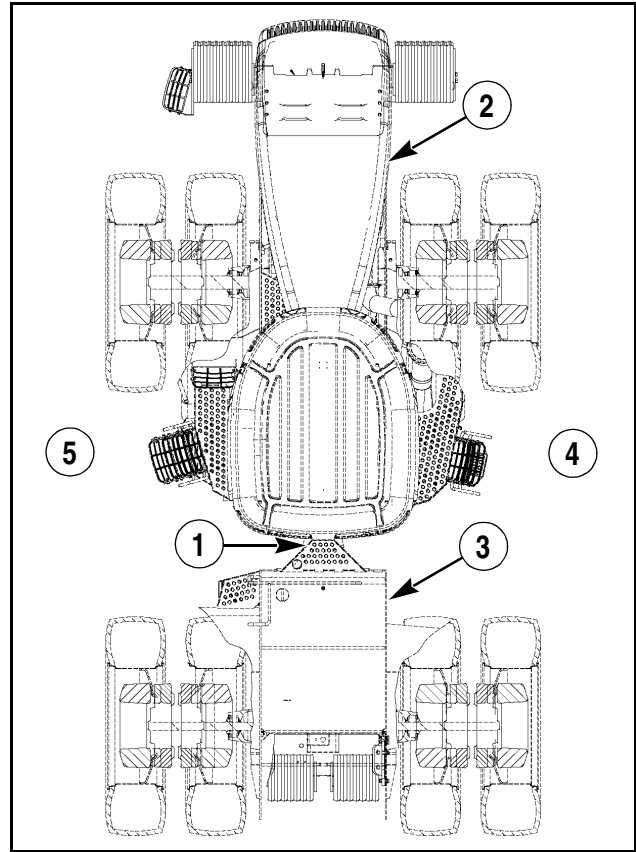

MA00A013

T9000 SERIES NEW HOLLAND TRACTOR

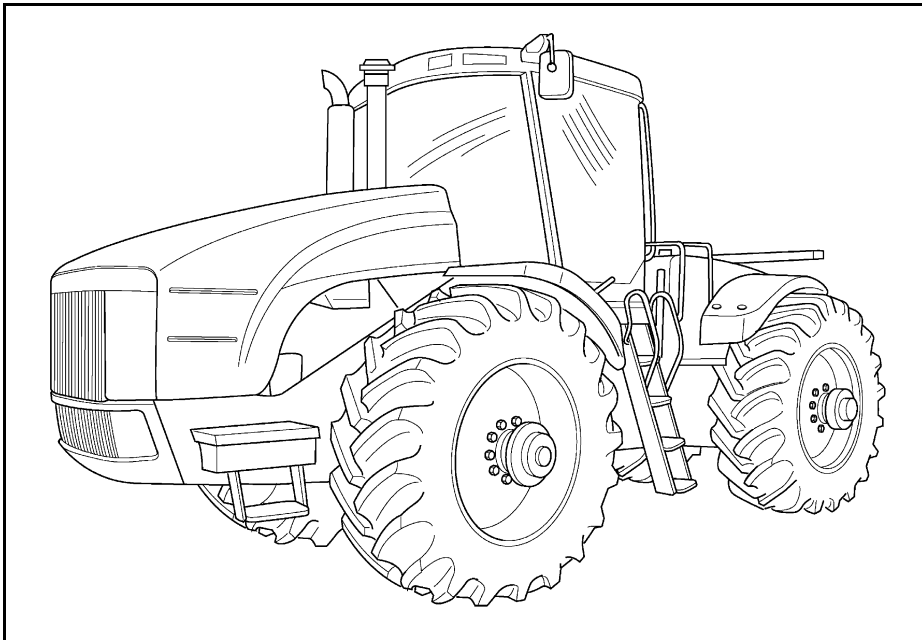

MK01G135

PRODUCT IDENTIFICATION AND SERIAL NUMBERS

Write your machine Model Number, Product Identification Number (P.I.N.) and Serial Numbers of major components on the lines provided. If needed,

give these numbers to your dealer when you need parts or information for your machine.

TRACTOR MODEL AND PRODUCT IDENTIFICATION NUMBERS

Model _____

P.I.N. *Z _____

Located on the upper back side of LH side front fender.

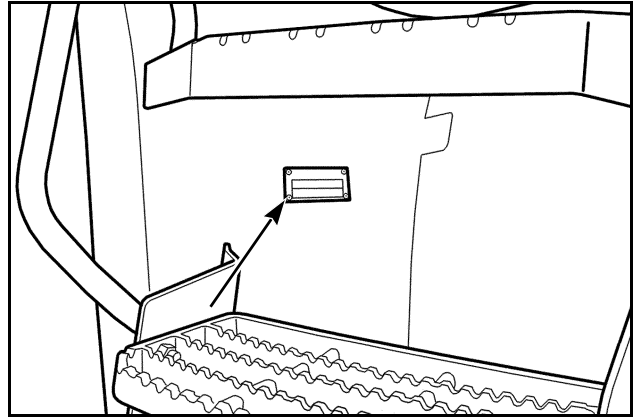

MT04M004

ROPS SERIAL NUMBER

*RVS _____

Located under the cover of the LH front ROPS post.

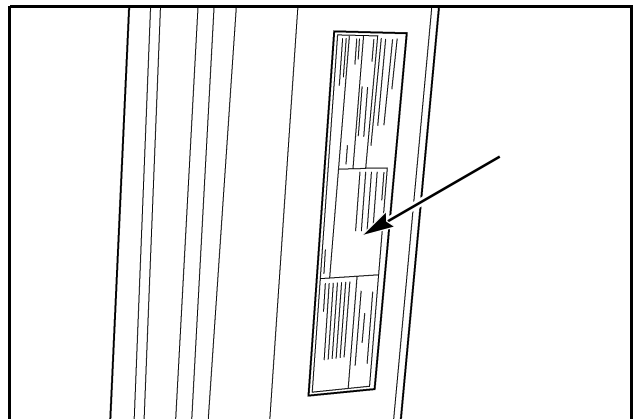

MK01G271

ENGINE SERIAL NUMBER (T9010, T9020)

Located on front LH side of engine.

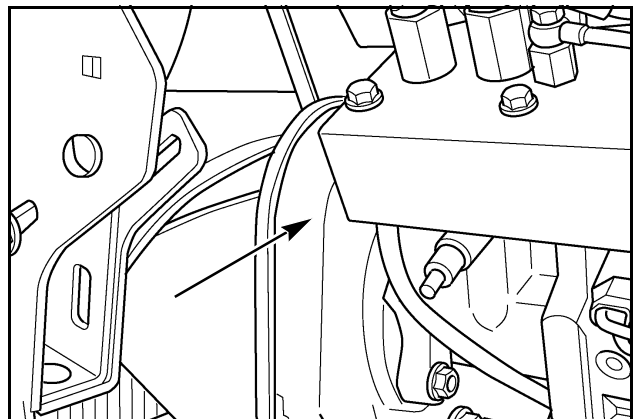

MK99K053

1-TO THE OWNER

ENGINE SERIAL NUMBER (T9030, T9040)

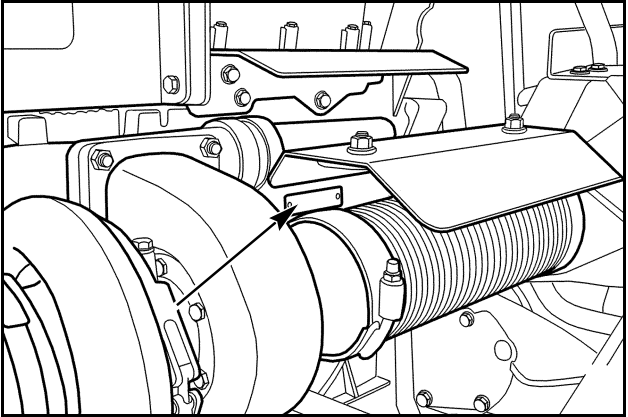

MT05M015

ENGINE SERIAL NUMBER (T9050, T9060)

Located on the top LH side of the engine valve cover.

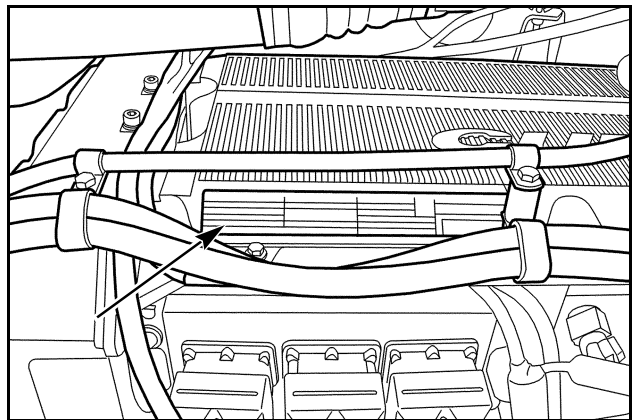

MT05M016

TRANSMISSION SERIAL NUMBER

Located on the LH rear side of the transmission.

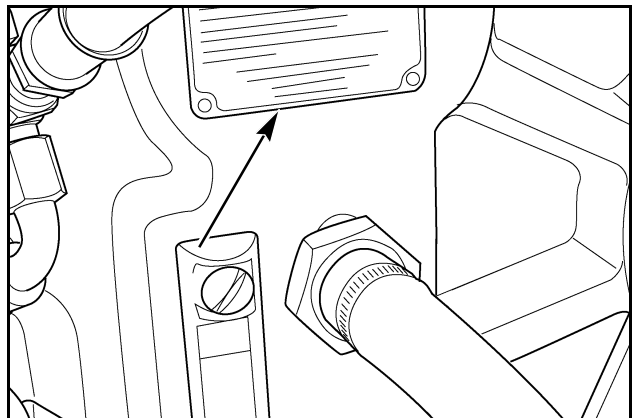

MK98C005

1-TO THE OWNER

AXLE SERIAL NUMBER (T9010, T9020)

Front _____

Rear _____

Located on the side of the axle center housing.

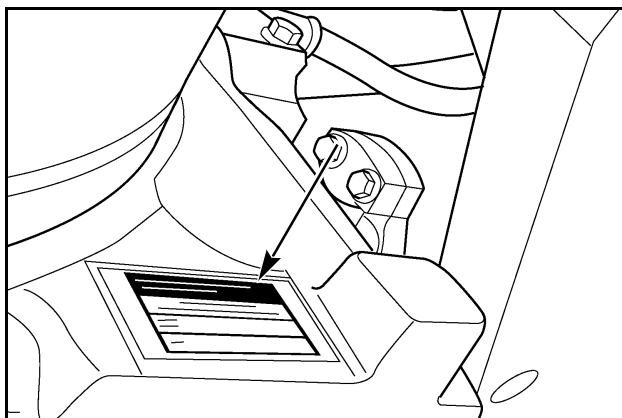

MK99K097

AXLE SERIAL NUMBER - (T9030, T9040, T9050, T9060)

Front _____

Rear _____

Located on the final drive housing.

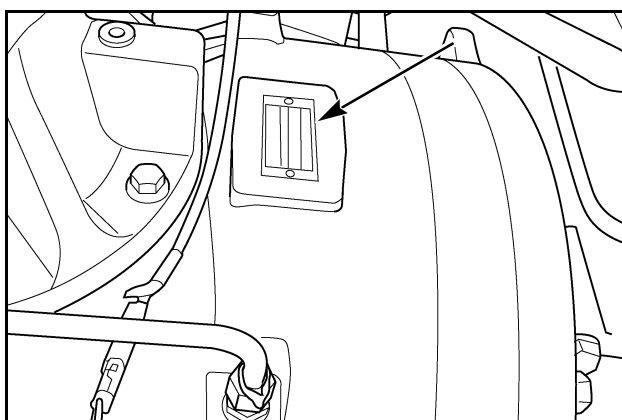

MK01G070

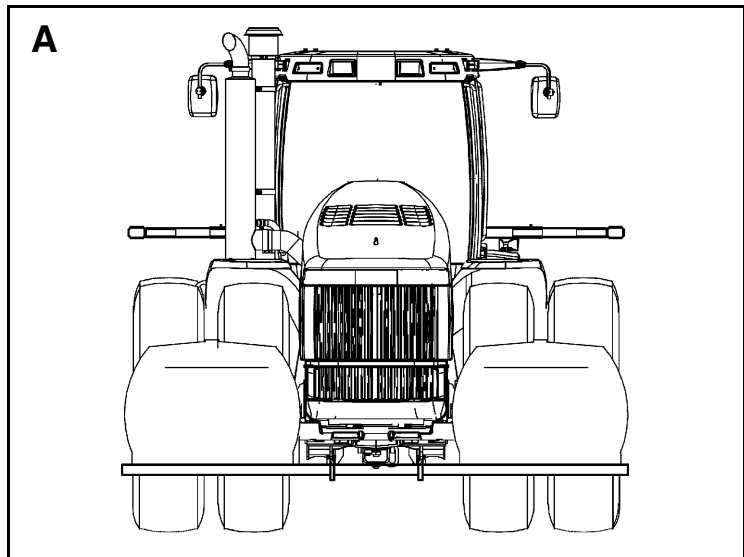

MA01G029

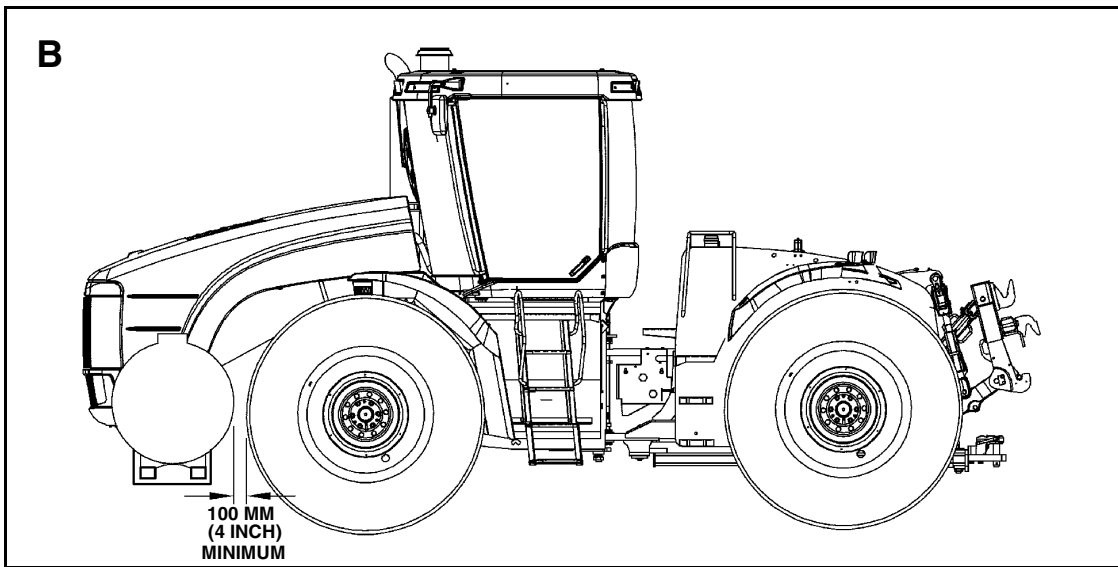

MA00G028

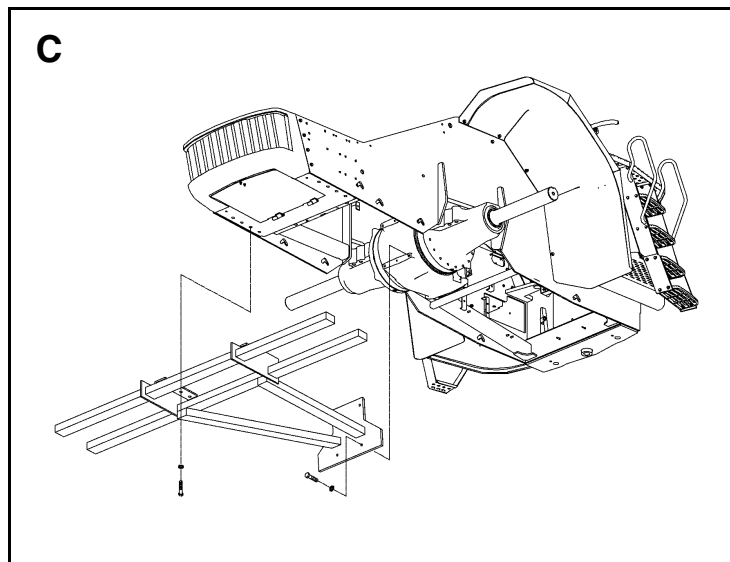

MA01G030

CHEMICAL TANK MOUNTING



WARNING: *Additional care must be taken when operating a tractor with chemical tanks. Operating, handling and braking performance of the tractor may be affected. Avoid high speed operation. Travel speed should be such that complete control and machine stability is maintained at all times.**

M418

Chemical tanks and mounting are not factory supplied. Chemical tanks can be mounted on each front side of the T9000 model tractors. The maximum tank capacity for side mounted installation is two 300 gallon (1136 liter) tanks for T9010 and 9020 models and two 350 gallon (1326 liter) tanks for T9030 through T9060 models.

To avoid structural damage, vendor supplied chemical tanks must be installed according to the following instructions:

1. Side mounted chemical tanks must be mounted in pairs with a rigid structure supporting both tanks (A). Side tanks must be interconnected so that the fluid level is the same in both tanks at all times.
2. Chemical tanks must be mounted as close to the front axle as possible. Front wheel tread setting is not affected by side tank installation, however the shape and/or size of the tanks can be affected by the required 100 mm (4 inch) minimum clearance in front of the tires (B).
3. The tank support structure must be attached to the front frame belly pan in the same location as the front suitcase weight support frame using class 10.9 fasteners (C).

IMPORTANT: *The tanks MUST NOT be individually supported by the tractor side frames.*

4. To reduce the dynamic forces associated with chemical tanks, the tank support structure must also have a rigid type brace extending from each side of the tank support structure to the front side of the front axle center housing. Use the existing pre-drilled and tapped 20 mm holes in the center housing to attach the braces using class 10.9 fasteners (C).
5. Front tanks must be mounted to allow the clean-out trap door to open and allow unrestricted access to all service points.
6. Refer to the Tire Load And Inflation Tables in this manual for the correct tire size and load capacity for your application. Tires must be inflated to the correct load capacity to support the added weight. To avoid exceeding tire load capacity, remove all front wheel weights.
7. Each U.S. gallon (3.8 liter) of tank capacity will add approximately 14 lb (6.3 Kg) to the front axle weight and decrease rear axle weight. DO NOT exceed tire or tractor maximum operating weights.

IMPORTANT: *Tanks filled to capacity must not be used as primary ballast for heavy tillage operation.*

NOTE: *A generic chemical tank support structure is illustrated only to show acceptable attaching points. Final support structure design and testing is the responsibility of the manufacturer.*

BUSINESS BAND RADIO READY (If Equipped)

Provisions for installing business band radios have been provided for tractors equipped with the Business Band Radio Option. The antenna mast mounting threaded spud (1) and antenna lead wire (if equipped) are factory installed in the roof of the cab approximately 2 inches (50 mm) under the cab top. The spud is already wired with RF-58/U cable.

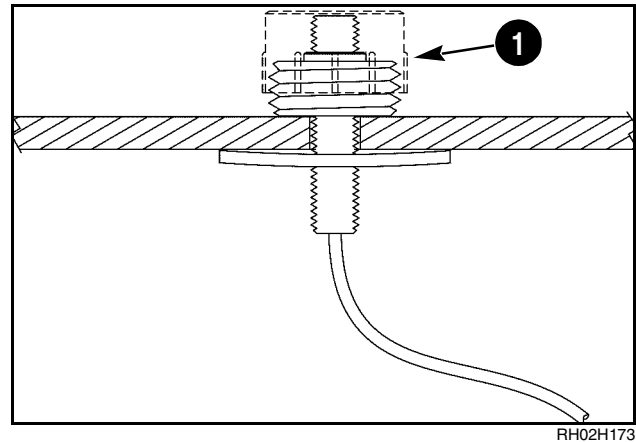

RH02H173

A locating dimple (2) in the cab top marks the location for drilling the hole for the antenna mast.

NOTE: The antenna mast for a one-quarter (1/4) wave UHF business band radio must be purchased locally and must be compatible with an Antenna Specialist Model K-794 low profile antenna mount. See Antenna Specialist at www.antenna.com for additional information.

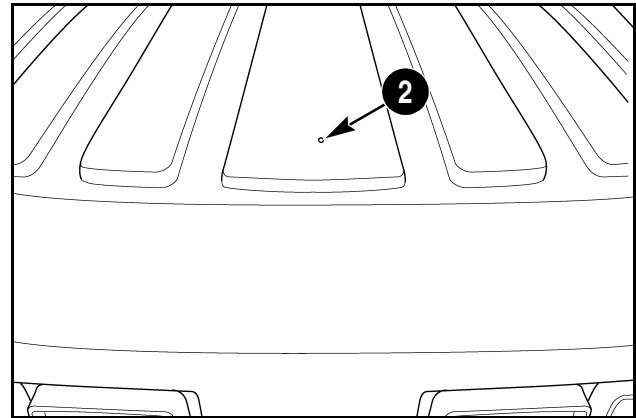

MK00E007

The radio antenna lead wire (if equipped) (3) and power and ground connector (4) are located under the right side rear ROPS post trim cover.

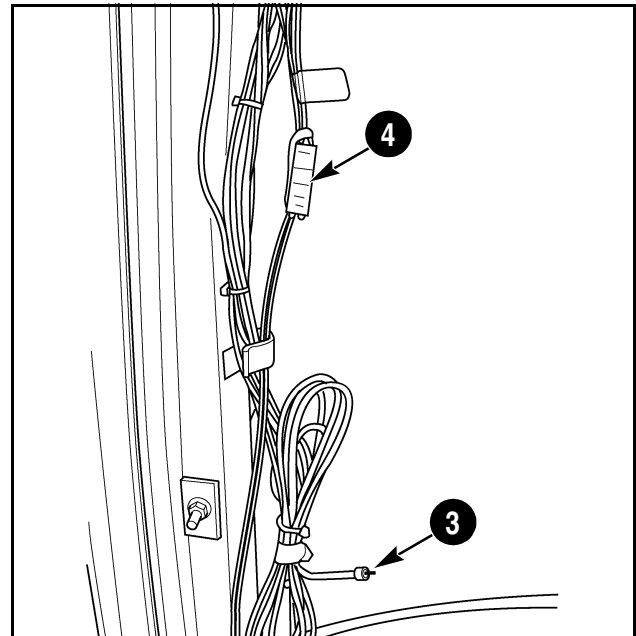

MK00E041

1-TO THE OWNER

The recommended location for mounting the business band radio is under the RH stereo speaker box. The mounting bracket supplied with the radio must be used.

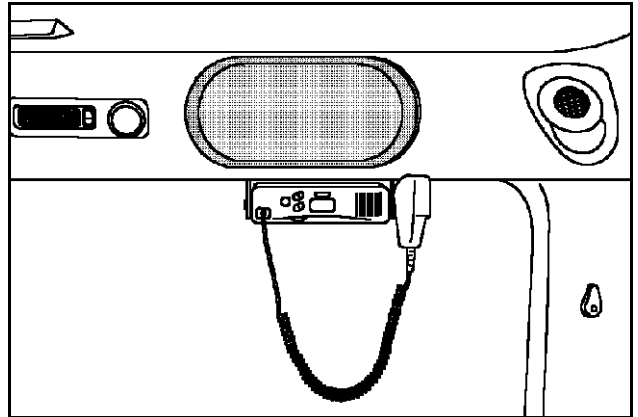

RI01009

If necessary, the stereo speaker may be removed to install the radio mounting bracket.

NOTE: See your dealer for additional information and procedures for installing a business band radio.

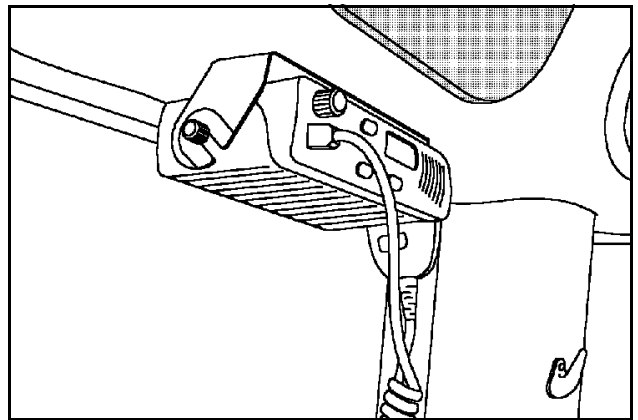

RI01D008

This Page Left Blank

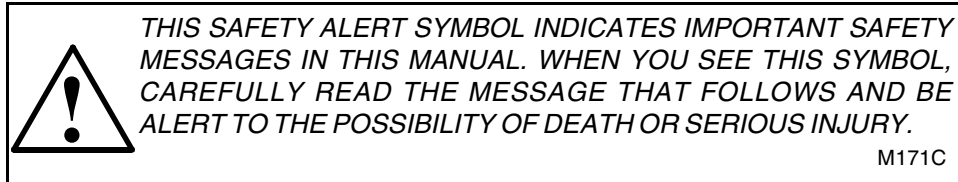

PERSONAL SAFETY ALERT



Safety Decals on this machine use the words **Danger, Warning or Caution**, which are defined as follows:

- **DANGER:** Indicates an immediate hazardous situation which if not avoided, will result in death or serious injury. The color associated with Danger is RED.
- **WARNING:** Indicates an potentially hazardous situation which if not avoided, could result in death or serious injury. The color associated with Warning is ORANGE.
- **CAUTION:** Indicates an potentially hazardous situation which if not avoided, may result in minor or moderate injury. It may also be used to alert against unsafe practices. The color associated with Caution is YELLOW.

If Safety Decals on this machine are ISO two panel Pictorial, decals are defined as follows:

- **The first panel indicates the nature of the hazard.**
- **The second panel indicates the appropriate avoidance of the hazard.**
- **Background color is YELLOW.**
- **Prohibition symbols such as**   **and**  **if used are RED.**

WARNING

IMPROPER OPERATION OF THIS MACHINE CAN CAUSE DEATH OR SERIOUS INJURY. BEFORE USING THIS MACHINE, MAKE CERTAIN THAT EVERY OPERATOR:

- Is instructed in safe and proper use of the machine.
- Reads and understands the Manual(s) pertaining to the machine.
- Reads and understands ALL Safety Decals on the machine.
- Clears the area of other persons.
- Learns and practices safe use of machine controls in a safe, clear area before operating this machine on a job site.

It is your responsibility to observe pertinent laws and regulations and follow New Holland instructions on machine operation and maintenance.

CALIFORNIA Proposition 65 Warning

Diesel engine exhaust and some of its constituents are known to the State of California to cause cancer, birth defects, and other reproductive harm.

Battery posts, terminals and related accessories contain lead and lead compounds. Wash hands after handling.

This section gives important safety information for your tractor.

SAFETY

Understand that your safety and the safety of other persons is measured by how you service and operate this machine. Know the positions and operation of all controls before you try to operate. **MAKE SURE YOU CHECK ALL CONTROLS IN A SAFE AREA BEFORE STARTING YOUR WORK.**

READ THIS MANUAL COMPLETELY and make sure you understand the controls. All equipment has limits. Make sure you understand the speed, brakes, steering stability and load characteristics of this machine before you start to operate.

The safety information given in this manual does not replace safety codes, insurance needs, federal, state and local laws. Make sure your machine has the correct equipment needed by the local laws and regulations.

CNH AMERICA, LLC is continuing to work for your safety by making tractors with better protection and by providing these rules for safe operation.



WARNING: THIS SAFETY ALERT SYMBOL INDICATES IMPORTANT SAFETY MESSAGES IN THIS MANUAL. WHEN YOU SEE THIS SYMBOL, CAREFULLY READ THE MESSAGE THAT FOLLOWS AND BE ALERT TO THE POSSIBILITY OF PERSONAL INJURY OR DEATH.

SM171B



Safety Rules



- Always sound horn before starting the tractor.
- Before starting the engine, be sure all operating controls are in neutral or park lock position. This will eliminate accidental movement of the machine or start up of power driven equipment. R106E
- Operate controls only when seated in the operators seat. R137A
- Securely fasten your seat belt. Your machine is equipped with a ROPS cab, ROPS canopy or ROPS frame for your protection. The seat belt can help insure your safety if it is used and maintained. Never wear a seat belt loosely or with slack in the belt system. Never wear the belt in a twisted condition or pinched between the seat structural members. Inspect seat belt webbing, buckle and retractors to ensure they are not damaged. If damage is apparent, repair before operating the tractor. M437A
- A frequent cause of death or serious injury is persons falling off machinery and being run over. Keep cab door closed. Instructional seat is used only for instructing or service diagnosing only. DO NOT permit others to ride, especially children. Seat belt (if equipped) must be worn at all times. M488C
- Before leaving the tractor, stop the engine, put all controls in neutral or park lock position, remove the key from the key switch. R301B
- Stay off slopes too steep for safe operation. Shift down before you start up or down a hill with a heavy load. Avoid “free wheeling”. R123A
- Do not drive on roads, or at high speed anywhere, with the differential lock engaged. Difficult steering will occur and can result in an accident. In field operation, use the differential lock for traction improvement, but release for turning at row ends. R116A



Safety Rules



- Travel speed should be such that complete control and machine stability is maintained at all times. Where possible, avoid operating near ditches, embankments and holes. Reduce speed when turning, crossing slopes, and on rough, slick or muddy surfaces. R109B
- Collision of high speed road traffic and slow moving machines can cause personal injury or death. On roads, use flasher lights according to local laws. Keep SMV emblem visible. Pull over to let faster traffic pass. Slow down and signal before turning off. R110E
- Make sure that the weight of a trailed vehicle that is not equipped with brakes, NEVER EXCEEDS the weight of the machine that is towing the vehicle. Stopping distance increases with increasing speed as the weight of the towed load increases, especially on hills and slopes. R114B
- Extra weight and bad traction conditions such as mud or ice increase your stopping distance. Remember that liquid in the tires, weights on the machine or wheels, tanks filled with fertilizer, herbicides or insecticides - all these add weight and increase the distance you need in which to stop. R138B
- PTO driven machinery can cause serious injury. Before working on or near the PTO shaft, or servicing or clearing the driven machine, put the PTO lever in the DISENGAGE position and STOP the engine. R154A
- Whenever a PTO driven machine is in operation, the PTO guard must be in place for most operations to prevent injury to the operator or bystanders. Where attachments, such as pumps, are installed on the PTO shaft (especially if the tractor PTO guard is moved upward or removed), extended shielding equivalent to the PTO guard must be installed with the attachment. Install the PTO guard to its original position immediately when the attachment is removed. R273A
- When doing stationary PTO work and dismounting from the tractor with the PTO running, keep clear of all moving parts as they are a potential safety hazard. R127A
- When doing stationary PTO work, install the front and rear frame articulation block to prevent accidental articulation of the tractor. Put the transmission control lever in the park position or apply the park brake. R298B
- Never operate the engine in a closed building. Proper ventilation is required under all circumstances. R142A
- Never refuel the machine when the engine is hot or running. Never smoke while refueling. R139C
- Check and service cooling system according to the maintenance instructions. Hot coolant can spray out if the deaeration tank cap is removed while system is hot. To remove the deaeration tank cap, let system cool, turn to first notch, then wait until all pressure is released. Scalding can result from fast removal of the cap. R141C
- Hydraulic oil or diesel fuel leaking under pressure can penetrate the skin and cause infection or other injury.
To Prevent Personal Injury:
Relieve all pressure before disconnecting fluid lines.
Before applying pressure, make sure all connections are tight and components are in good condition.
Never use your hand to check for suspected leaks under pressure.
Use a piece of cardboard or wood for this purpose. If injured by leaking fluid, see your doctor immediately. R149B
- Battery explosion and/or damage to electrical components can result from improper connection of booster batteries or charger. Connect positive to positive and negative to negative. Externally, battery acid can cause burns and blindness, and taken internally it is poisonous. R146B
- It is good practice to carry a fire extinguisher on the machine. Be sure that the extinguisher is properly maintained and be familiar with its proper use. R102B
- Clean tractor of field trash daily or more frequently depending upon conditions. Trash accumulation on the tractor can cause damage and fire. M791



Safety Rules



- Do not turn the steering wheel until everyone is clear of the equipment and the center hinge area. Turning the steering wheel can swing the tractor and equipment from side to side. R303A
- Always use the hand rails when mounting or dismounting from the tractor. Always face the tractor when mounting and dismounting. This will provide more secure hand and feet mobility to help prevent slipping and possible injury. R304A
- Always keep the cab windows and rear view mirrors clean to provide the best all around visibility while operating the tractor. R416
- Do not pull with elastic tow ropes. Elastic tow rope stores energy. Sudden release may cause injury or death. M425
- Young children should not be permitted to operate or ride the tractor under any circumstances. M630
- Do not look directly into the High Intensity Discharge Head Lamp. Eye damage can occur. M638
- Do not tamper with the ballast on the High Intensity Discharge Head Lamp as it contains high voltage. Personal injury or death can occur. M639
- To prevent tractor movement, always apply the park brake whenever the tractor is parked with the engine running. The park brake is applied automatically when the engine is shut down. M627
- Always start the engine from the operators seat. Never attempt to bypass start, the tractor may suddenly start and move resulting in serious or fatal injury. M787
- To avoid possible eye damage from microwave signals emitted by the radar sensor, do not look directly into the sensor face. M788
- The operator cab does not protect against inhaling harmful pesticides or chemicals. Please utilize an approved respirator or other personal protection equipment as recommended by the chemical supplier when using these materials. M792



INSTRUCTIONAL SEAT SAFETY



- Extra riders, especially children, are not permitted to ride on the machine.
- The Instructional Seat is used only when training a new operator or when a service technician is diagnosing a mechanical problem.
- A frequent cause of personal injury or death is persons falling off and being run over. DO NOT permit others to ride, except in designated instructional seat.
- When the Instructional Seat is occupied, the following precautions must be taken:
 - A. Machine should be driven at a slower speed and on level ground.
 - B. Avoid driving on highways or public roads.
 - C. Avoid quick starts or stops.
 - D. Avoid sharp turns.
 - E. Always wear seat belts.
 - F. Cab door must be closed at all times.



WARNING: Before starting the engine make sure seat belts are securely fastened. The seat belt can help ensure your safety if it is used and properly maintained. Never wear a seat belt loosely or with slack in the belt system. Never wear the belt in a twisted condition or pinched between the seat structural members.

M422B



WARNING: A frequent cause of personal injury or death is persons falling off and being run over. DO NOT permit others to ride, except in designated instructional seat. Instructor must wear the instructional seat belt.

M488A



MAINTENANCE SAFETY



- Always keep safety and informational decals clean and visible. Replace decals that are damaged, lost, painted over or can not be read.
- When assembling, operating or servicing the machine, wear protective clothing and personal safety devices that are necessary for the particular procedure. Some personal safety devices that may be necessary are protective shoes, face and/or eye protection, hard hat, heavy gloves, filter mask and hearing protection.
- DO NOT wear jewelry or loose fitting clothing that may get caught in moving parts. Always wear close fitting clothing. Keep hands, feet, clothing and hair away from moving parts.
- Never attempt to clear obstructions or objects from the machine while the engine is running.
- Always stop the engine and remove the key from the key switch when leaving the operator's seat or the machine.
- When servicing the machine, always have the machine on a firm level surface.
- If shields or guards are removed or opened for service, always replace them before operating the machine. Never operate machine with missing or open shields or guards.
- Keep the area used for servicing the machine clean and dry. Wet or oily floors are slippery. Wet spots can be dangerous when working with electrical equipment. Be sure all electrical outlets and tools are properly grounded.



FIRE SAFETY



- Fire risks can be minimized by frequent removal of accumulated crop material, trash or debris from the machine.
 - Remove all crop material, trash or debris from the machine each day. Especially check the engine area and exhaust system.
 - Engine fuel can cause an explosion or fire. DO NOT fill the fuel tank with the engine running; if you are near an open fire; or if you are welding, smoking, etc.
 - DO NOT use ether or starting fluid to start tractors equipped with a grid heater in the engine intake system. Using ether or starting fluid can result in an explosion or fire.
- Refer to Fire Prevention in the Maintenance Section of this manual for additional information.



BATTERY SAFETY



- DO NOT make sparks or use an open flame near the battery.
- When disconnecting battery terminals, remove the Negative (-) cable first; then remove the Positive (+). When connecting cables, connect the Positive (+) cable first, then connect the Negative (-).
- Disconnect the battery (both terminals) before welding on any part of the machine. Failure to do so may cause damage to sensitive electrical components.
- BATTERY ACID CAUSES SEVERE BURNS. Batteries contain sulfuric acid. Avoid contact with skin, eyes or clothing. Antidote: EXTERNAL - flush with water. INTERNAL - Drink large quantities of water or milk. DO NOT induce vomiting. Seek medical attention immediately. EYES - Flush with water for 15 minutes and seek medical attention immediately. BATTERIES PRODUCE EXPLOSIVE GASES. Keep sparks, flame, cigars and cigarettes away. Ventilate when charging or using in enclosed area. Always wear eye protection when working near batteries. Wash hands after handling. KEEP OUT OF REACH OF CHILDREN.
- When working around storage batteries, remember that all of the exposed metal parts are "live". Never lay a metal object across the terminals because a spark, short circuit, explosion or personal injury may result.
- Battery posts, terminals and related accessories contain lead and lead compounds. **Wash hands after handling.**



MACHINE OPERATION AND ROLL-OVER SAFETY



- DO NOT allow other persons to ride on the machine. Other persons can fall or can cause an accident.
- DO NOT operate the machine while under the influence of alcohol or drugs.
- Be alert and always know the location of all workers in your area. Keep all other persons completely away from your machine. Injury or death can result if you do not follow these instructions.
- Before you service your machine, check the MSDS for each fluid, lubricant, etc., used in this machine. This information indicates what the risks are and how to service the machine safely. Follow this information when servicing the machine.
- Before you service this machine and before you dispose of the old fluids and lubricants, always remember the environment. DO NOT put oil or fluids into the ground or into containers that can leak.
- Check with your local environmental or recycling center or your dealer for correct disposal information.