

D180 Power Steering D180 LGP

CRAWLER DOZER

Workshop manual

Print No. 604.02.274.00 English



THIS ALERT SYMBOL SIGNALS IMPORTANT MESSAGES INVOLVING YOUR SAFETY.

Read and heed carefully the safety instructions listed and follow the precautions recommended to avoid potential risks and to safeguard your health and your safety.

You will find this symbol in the text of this Manual referred to the following key words:

WARNING - Cautions directed to avoid improper repair interventions involving potential consequences for the safety of the personnel performing the repairs.

DANGER - These warnings qualify specifically potential dangers for the safety of the operator or other persons directly or indirectly involved.

IMPORTANT NOTICE

All maintenance and repair interventions explained in this Manual **must be performed exclusively by the Service Organisation of the Manufacturer**, observing strictly the instructions explained using, whenever necessary, the recommended specific tools.

Whoever performs the operations reported without following exactly the precautions is responsible on his own, for the damages that may result.

Neither the Factory nor any Organisations in its Distribution Network, including but not limited to national, regional or local distributors, are responsible for any liability arising from any damage resulting from defects caused by parts and/or components not approved by the Factory for use in maintaining and/or repairing products manufactured or merchandised by the Factory.

In any case, no warranty of any kind is made or shall be imposed with respect to products manufactured or merchandised by the Factory, when failures are caused by the use of parts and/or components not approved by the Factory.

AVOID ACCIDENTS

Most accidents, whether they occur in industry, on the farm, at home or on the road, are caused by the failure of some individuals to follow simple and fundamental safety rules and precautions. For this reason **MOST ACCIDENTS CAN BE PREVENTED** by recognising the real cause and doing something about it before the accident occurs.

Regardless of the care used in the design and construction of any type of equipment, there are many conditions that cannot be completely safeguarded against without interfering in the reasonable accessibility and efficient operation.

A careful operator is the best insurance against an accident. The complete observance of one simple rule would prevent many serious accidents.

The rule is simple: never attempt to clean, lubricate or maintain a machine while it is in motion.



WARNING

Prior to engaging in any maintenance, adjustment or repair operation on machines having hydraulically, mechanically, and/or cable controlled equipment (such as shovels, loaders, dozers, excavators etc.) be certain the equipment is lowered to the ground.

If it is necessary to have the equipment partially or fully raised to gain access to certain items, be sure the equipment is suitably supported by means other than the devices used for controlling the equipment.

SUMMARY

GENERALITIES	SECT. 0
ENGINE	SECT. 1
TRANSMISSION	SECT. 2
FINAL DRIVES	SECT. 3
BRAKES AND STEERING CLUTCHES	SECT. 4
UNDERCARRIAGE	SECT. 5
DOZING EQUIPMENT	SECT. 6
HYDRAULIC SYSTEM	
ELECTRICAL SYSTEM	SECT. 7

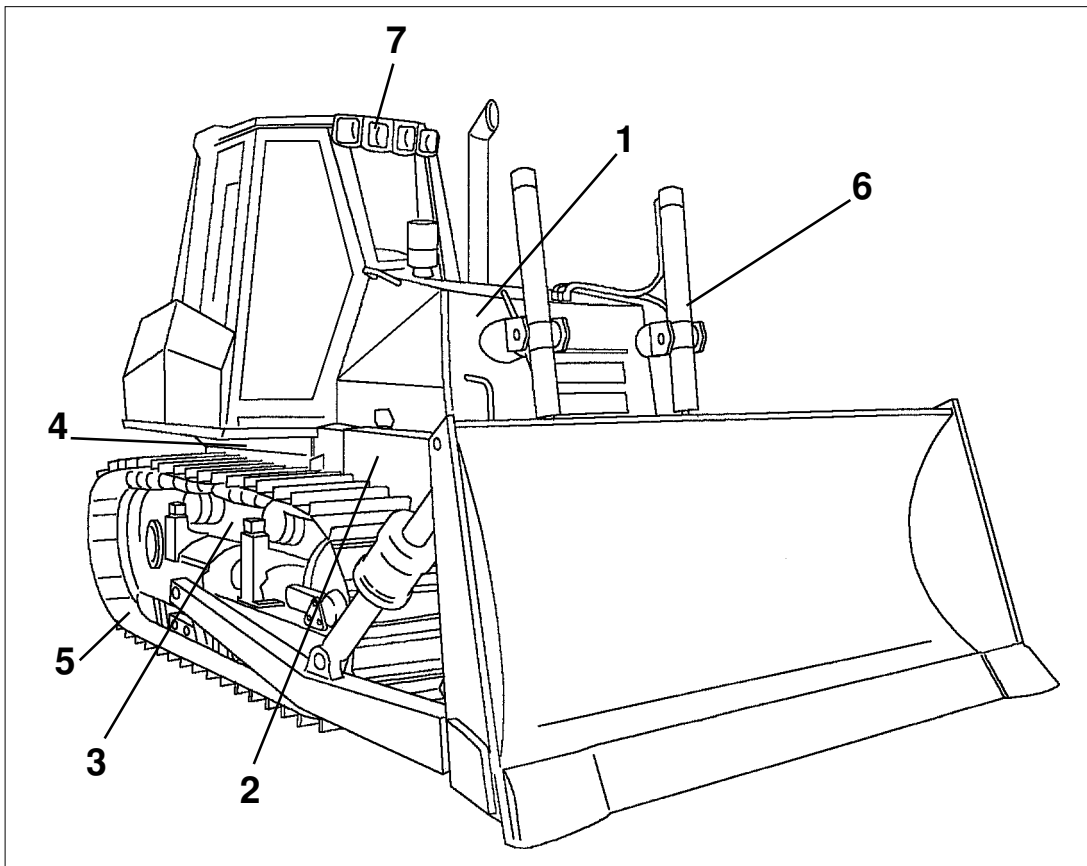

SECTION 0
GENERALITIES

TABLE OF CONTENTS

SUBJECT	PAGE
SAFETY RULES	I-VIII
TABLE OF TECHNICAL DATA	
Table fluid capacities	0-1
Main dimensions	0-2
Technical data tables	0-4
CONTROL DATA ON THE MACHINE	0-18
TABLE OF WEIGHTS	0-19
LIST OF WEIGHTS FOR MAIN SERVICE COMPONENTS	0-21
CENTRE OF GRAVITY TABLE	0-23
GENERAL INSTRUCTIONS	0-24
TROUBLESHOOTING	0-29
UNITS OF MEASURE	0-30
TABLE OF TIGHTENING TORQUES	0-32

WARNING

Study carefully this Manual before starting, operating, maintaining, fuelling or servicing the machine.

Read and heed all safety rules before any intervention.

SAFETY RULES

- Do not allow unauthorised personnel to operate service or maintain this machine.
- Do not wear rings, wrist watches, jewellery, loose or hanging apparels, such as ties, torn clothing, scarves, unbuttoned or unzipped jackets that can catch on moving parts. Wear proper safety equipment as recommended for the job. Examples: hard hat, heavy gloves, ear protection, safety glasses or goggles, reflector vests, respirator. Consult your employer for specific safety equipment requirements.
- Keep operator's compartment, stepping points, grab-rails and handles clear of foreign objects, oil, grease, mud or snow accumulation to minimise the danger of slipping or stumbling. Clean mud or grease from shoes before attempting to mount or operate the machine.
- Do not jump on or off the machine. Keep two hands and one foot, or two feet and one hand in contact with step grab rails and handles at all times.
- Do not use controls or hoses as hand holds when climbing on or off machine. Hoses and controls are movable and do not provide a solid support. Also, controls may be inadvertently moved causing accidental machine or equipment movement.
- Never attempt to operate the machine or its tools from any position other than seated in the operator's seat.
- Keep head, body, limbs, hands and feet inside operator's compartment at all times, to reduce exposure to hazards outside the operator's compartment.
- Be careful of slippery conditions on stepping points, hand rails, and on the ground. Wear safety boots or shoes that have a high slip resistant sole material.
- Do not leave the machine until it is completely stopped.
- Check the seat safety belt at least twice a year. If there are signs of wear or fraying or other signs of weakness that could lead to failure, replace it.
- Check brakes, steering and attachment controls before moving. Advise the proper maintenance authority of any malfunctioning part or system.
- Be sure all protective guards or panels are in place, and all safety devices provided are in place and in good operating conditions.
- Be sure exposed personnel in the area of operation are clear of the machine before moving it or its attachments. **WALK COMPLETELY AROUND** the machine before mounting. Sound horn.
- Before starting machine, check, adjust and lock the operator's seat for maximum comfort and control of the machine.
- Fasten your seat belt (when provided).
- Obey all flag signals and signs.
- Due to the presence on the machine of flammable fluids, never check or fill fuel reservoirs or batteries near open flames, smoking materials or sparks.
- **REMEMBER THAT STARTING FLUID IS FLAMMABLE.** Follow strictly the recommendations printed on containers and in the Operation and Maintenance Manual.
- **DO NOT PUNCTURE OR BURN CONTAINERS.**
- Containers must be stored in fresh, well ventilated places, out of reach of unauthorised persons. Follow strictly the instructions provided by the Manufacturer.
- Never use these products near open flames, smoking materials or sparks.

STARTING

- **NEVER START NOR OPERATE AN UNSAFE MACHINE.** Before operating a machine, always ensure that any unsafe condition has been satisfactorily remedied.

OPERATION

- Do not run the engine of this machine in closed areas without proper ventilation to remove deadly exhaust gases.
- Roll Over Protective Structures are required on loaders, dozers, graders, excavators. **NEVER OPERATE** machines without ROPS.
- Make sure the Operator's compartment is free of foreign objects, especially if not firmly secured. Never use the machine to transport objects, unless proper securing points are provided.

SAFETY RULES

- Check monitoring instruments at start-up and frequently during operations. In case the brake pressure gauge shows a pressure lower than the minimum operating pressure, stop immediately the machine .
- DO NOT CARRY RIDERS ON MACHINE
- Study and familiarise with escape routes alternate to normal exit routes.
- Seat belts are required by current regulations to be provided with Roll Over Protection Structures or cabs. Keep safety belts fastened around you during operation.
- For your personal protection, do not climb on or off machine while machine is in motion.
- Make sure that exposed persons in the area of operation are clear of the machine, before starting the engine and operating the equipment. Sound horn. Obey all indications provided by flags and signals.
- NEVER COAST the machine down grades and slopes with the transmission in neutral or neutralised.

Choose and shift into the most appropriate gear to keep the speed required, thus preventing any loss of control.
- Do not operate machinery in a condition of extreme fatigue or illness. Be especially careful towards the end of working shift.
- Do not operate machine with brakes out of adjustment.
- Operate the machine at speeds slow enough to ensure complete control at all times.
- Travel slowly over rough terrain, on slopes or near drop-offs, in congested areas or on ice or slippery surfaces.
- When backing, always look to where the machine is to be moved. Be alert to the position of exposed personnel. DO NOT OPERATE if exposed personnel enter the immediate work area. STOP THE MACHINE.
- Maintain a safe distance from other machines. Provide sufficient clearance for ground and visibility conditions. Yield right-of-way to loaded machines.
- Maintain clear vision of areas of travel or work. Keep cab windows clean and repaired.
- When machines are operating in tandem, the pusher (rear) must be equipped with the appropriate deflectors to protect the unit in front from the air stream coming from the radiator.
- When pulling or towing through a cable or chain, do not start suddenly at full throttle; take-up slack carefully.

Inspect carefully for flaws or troubles before using.
- Avoid kinking chains or cables. Do not pull through a kinked chain or cable to the high stresses and possibility of failure of the kinked area. Always wear heavy gloves when handling chains or cables.
- Be sure chains and cables are anchored and the anchor points are strong enough to handle the expected load. Keep exposed personnel clear of anchor points and cables or chains.
- DO NOT PULL UNLESS OPERATOR'S COMPARTMENT OF MACHINES INVOLVED ARE PROPERLY GUARDED AGAINST POTENTIAL CABLE OR CHAIN BACKLASH.
- Be alert to soft ground conditions close to newly constructed walls. The fill material and weight of the machine may cause the wall collapse under the machine.
- In darkness, check area of operation carefully before moving in with machine. Use all lights provided. Do not move into area of restricted visibility.
- If engine has a tendency to stall for any reason under load or idle, report this for adjustment to proper maintenance authority immediately. Do not continue to operate machine, until condition has been corrected.
- On machines supplied with suction radiator fans, be sure to periodically check engine exhaust parts for leaks, as exhaust fumes are dangerous to the operator.
- In case of closed type cabs, always keep an opening with the outside, to ensure a constant air circulation.
- Operators must know thoroughly the performances of the machine they are operating. When working on slopes or near sudden level drops of the terrain, avoid areas where ground is loose or soft since rolling-over or loss of control of machine could result.
- Where noise exposure exceeds 90 dBA for 8 hours, wear approved ear protection.
- When counterweights are provided, do not work machine if they have been removed.
- Overtaking manoeuvres must be performed only when absolutely necessary and unavoidable. Beware of possible uneven terrains, poor visibility conditions, the presence of other machinery or persons out of sight.
- Operate the machine at a speed adequate to the working conditions in the site and slow enough to ensure complete control at all times.
- Never use the machine as a work platform or scaffolding, nor other inappropriate operations (i.e. pushing railway cars, trucks or other machines).
- Be alert of people in the operating area of the machine.
- When operating a machine, know in advance what clearances will be encountered, overhead doors, cables, pipes, bearing load limitations of ground, bridges, floors or ramps.

SAFETY RULES

- When roading, find-out what conditions are likely to be encountered, clearances, traffic congestion, type of road surfacing, etc. Beware of fog, smoke or dust elements that obscure visibility.
- When crossing gullies or ditches, move at an angle with reduced speed after ensuring ground conditions will permit a safe traverse.
- Explore the working area to identify potential risks such as: slopes, overhangs, pits, demolition rubble, fires, ravines, ditches, soft terrain, heavy traffic, crowded parking areas, closed ambients. In such conditions, proceed with extreme care.
- Whenever possible, avoid going over obstacles such as rough terrain, rocks, logs highly irregular ground, steps, ditches, railroad tracks. When obstructions must be crossed, do so with extreme care at an angle, if possible. Reduce speed, shift-down. Ease up to the break over point, pass the balance point slowly on the obstruction and ease down on the other side.
- In steep down-hill operation, do not allow engine to over-speed. Select proper gear before starting down grade.
- Avoid side hill travel, whenever possible. Drive up and down the slope. Should the machine slipping sideways, turn it immediately downhill.
- The grade of slope you should attempt will be limited by factors such as condition of the ground, load being handled, type of machine, speed of machine and visibility.
- There is no substitute for good judgement when working on slopes.
- Avoid operating equipment too close to an overhang or high wall, either above or below the machine. Be on the look-out for caving edges, falling objects and slides. Beware of concealment by brush and undergrowth of these danger.
- When pushing-over trees, the machine must be equipped with proper overhead guarding. Never allow a machine to climb up on the root structure particularly while the tree is being felled. Use extreme care when pushing over any tree with dead branches.
- When pushing trees with dead limbs, proceed with extreme care. Avoid brush piles, logs or rocks.
- NEVER DRIVE OVER THEM or other surface irregularities that brake traction with the ground, especially when on slopes or near drop-offs.
- Be alert to avoid changes in traction conditions that could cause loss of control. DO NOT DRIVE on ice or frozen ground conditions when working the machine on steep slopes or near drop-offs.
- Working in virgin and rough terrains is characterised by the presence of all the perils and risks listed above. In these conditions, it is emphasised the danger represented by large tree limbs (possibly falling on the machine), large roots (acting as a leverage under the machine when up-rooted causing the roll-over of the unit) etc..

STOPPING

- When the machine is stopped for whatever reason, follow the instructions of chapters "**Stopping the machine**" and "**Stopping the engine**" of the Operation and Maintenance Instruction Manual.
- Always remember to position the transmission drive control in neutral and engage the control lock to secure the machine.
- The parking brake is automatically set, when the transmission safety lever is lowered.
- NEVER LEAVE THE MACHINE UNATTENDED with the engine running.
- Always, before leaving the operator's seat and after making sure all people are clear of the machine, slowly lower the attachments or tools flat to the ground in a positive ground support position.
- Return the controls to rest position. Place the gearshift lever in neutral. Disconnect the master switch and extract the key.
- Park in a non- operating and no-traffic area or as instructed. Park on firm level ground if possible. Where not possible, position machine at a right angle to the slope, making sure there is no danger of uncontrolled sliding movements.
- If parking in traffic lanes cannot be avoided, provide appropriate flags, barriers, flares and signals as required. Also provide advance warning signals in the traffic lane of approaching traffic.
- Keep head, body, limbs, feet, fingers or hands away from bucket, blade or ripper when in raised position.
- Always disconnect the master switch before any intervention (i.e. cleaning, repairing, maintaining, refuelling etc.). Do the same when parking for prolonged periods of time to avoid accidental or unauthorised starting.

SAFETY RULES

- Never lower attachments or tools other than seated in operator's seat. Sound horn. Make sure area near the attachment is clear. Lower the attachment slowly. **DO NOT USE FLOAT POSITION** of hydraulic system.
- Place master switch in **OFF**, securely block the machine and lock it every time you leave it unattended. Return keys to authorised security. Heed all shut-down operations of the Operation and Maintenance Instruction Manual are followed.

MAINTENANCE

GENERALITIES

- Before operating or performing any intervention on the machine:
 - read carefully all the rules contained by this Manual;
 - read and obey all safety related plates and instructions located on the machine.
 - Do not allow unauthorised personnel to perform any maintenance operation. Do not perform maintenance operation without prior authorisation. Follow all recommended maintenance and service procedures.
 - Keep operator's compartment free of all loose objects that are not properly secured.
 - Do not wear rings, wrist watches, jewellery, loose or hanging apparels, such as ties, torn clothing, scarves, unbuttoned or unzipped jackets that can catch on moving parts. Wear proper safety equipment as recommended for the job. Examples: hard hat, heavy gloves, ear protection, safety glasses or goggles, reflector vests, respirator. Consult your employer for specific safety equipment requirements.
 - Do not use controls or hoses as hand holds when climbing on or off machine. Hoses and controls are movable and do not provide a solid support. Also, controls may be inadvertently moved causing accidental machine or equipment movement.
 - Do not jump on or off the machine. Keep two hands and one foot, or two feet and one hand in contact with step grab rails and handles at all times.
 - Do not perform any service operation on the machine with a person seated in the operator's compartment, unless he is an authorised operator co-operating in the operation to be performed.
 - Keep operator's compartment, stepping points, grab-rails and handles clear of foreign objects, oil, grease, mud or snow accumulation to minimise the danger of slipping or stumbling.
- Clean mud or grease from shoes before attempting to mount or operate the machine.
- Keep shoes free of mud or grease before climbing or driving the machine.
 - Never attempt to operate the machine or its tools from any position other than seated in the operator's seat.
 - When maintenance operations require moving hydraulically operated attachments by means of machine's hydraulic system remember that all manoeuvres must be made only when seated in the operator's seat. Before starting machine or moving attachment or tools, set brakes, sound horn and call for an all clear. Raise attachment slowly.
 - Always block booms or parts of the machine which must be raised to perform interventions under them with external devices. Do not allow persons to move into the vicinities nor standing under equipment not being blocked. Unless you are totally sure about your safety, avoid staying under raised equipment, even in case it is blocked.
 - Do not place the body, limbs or fingers into sharp articulation uncontrolled openings of the machine and without proper protections, unless they are blocked in a safe manner.
 - Never perform interventions with engine running, except as called for in a Manual. Do not wear loose clothing or jewellery near moving parts.
 - When servicing or maintenance require access to areas that cannot be reached from the ground, use a ladder or step platform that meet local and national regulations, to reach the service point. If such ladder or platform are not available, use the machine hand holds and steps as provided. Perform all service or maintenance carefully.
 - Shop and/or field service platforms or ladders must be constructed and maintained in accordance with local and national regulations.
 - Disconnect batteries and tag all controls according to current regulations to warn that work is in progress. Block machine and all attachments that must be raised according to current regulations.
- Due to the presence of flammable fluids, never check or fill fuel tanks, batteries, nor use starting fluid near lighted smoking materials or open flames.
- **BRAKES ARE INOPERATIVE** when manually released for servicing. Provisions must be made to maintain control of the machine by blocking or other means.
 - The fuel filling nose must be kept constantly inside the filling neck. Keep this contact from the beginning to the end of the fuelling operation to avoid the possibility that sparks due to static electricity are generated.

SAFETY RULES

- Use only designated towing or attaching points. Use care in making attachments. Make sure pins and/or locks are secure before pulling. Stay clear of drawbars, cables or chains under load.
- To move a disabled machine, use a trailer or a low-boy, if available. In case towing is needed, use all necessary signals required by local and national regulations, and follow the directions provided in this Manual.
- To load/unload a machine from transporter, choose a level surface ensuring firm support to the wheels of truck or trailer. Use strong access ramps, with adequate height and angle. Keep surface free of mud, oil or slippery materials.
- Anchor the machine securely to the bed of truck or trailer and block wheels or tracks with appropriate wedges.
- Never align holes with fingers or hands; always use appropriate aligning tools.
- Eliminate all sharp edges and burrs from re-worked parts.
- Use only approved grounded auxiliary power sources for heaters, chargers, pumps and similar equipment to reduce the hazards of electrical shocks.
- Lift and handle heavy parts with a lifting device of proper capacity. Be sure parts are supported by proper slings and hooks. Use lifting eyes if provided. Watch-out for people in the vicinity.
- Never pour gasoline or diesel fuel into open, wide and low containers. Never use gasoline, solvent or other flammable fluid to clean parts. Use exclusively qualified, non-flammable, non-toxic commercial solvents.
- When using compressed air for cleaning parts, use safety glasses with side shields or goggles. Limit pressure to 2 bar, in accordance with local and national regulations.
- Do not run the engine in closed areas without proper ventilation to remove deadly exhaust fumes.
- Do not smoke or permit any open flames or spark near when re-fuelling or handling flammable materials.
- Do not use an open flame as a light source to look for leaks or for inspection anywhere on the machine.
- Make sure that all mechanic's tools are in good conditions. NEVER USE tools with mushroomed heads or frayed. Always wear eye protections.
- Move with extreme care when working under the machine, its attachments and or on or near them. Always wear protective safety equipment as required, such as hard hat, goggles, safety shoes, ear plugs.
- When performing operations requiring running of the engine, have a qualified operator in the operator's seat at all times with the mechanic on sight. Place the transmission in neutral and set the brakes and safety lock.
- KEEP HANDS AND CLOTHING AWAY FROM MOVING PARTS.
- For field service, move machine to level ground, if possible, and block it. If work on an incline is absolutely necessary, first block machine and its attachments securely, then move it to level ground as soon as possible.
- Do not trust worn and /or kinked chains and cables: do not use them for lifting or pulling operations. To handle them, always use heavy gloves.
- Be sure chains and cables are anchored and the anchor points are strong enough to handle the expected load. Keep exposed personnel clear of anchor points and cables or chains.
- No bystanders are allowed near the hooking points, chains or cables.
- DO NOT PULL UNLESS OPERATOR'S COMPARTMENT OF MACHINES INVOLVED ARE PROPERLY GUARDED AGAINST POTENTIAL CABLE OR CHAIN BACKLASH.
- Keep the area where maintenance operations are performed CLEAN and DRY. Eliminate immediately all water and oil spillages.
- Do not pile oily or greasy rags; they represent a fire hazard. Store in closed metal container.
- Before starting machine, check, adjust and lock the operator's seat for maximum comfort and control of the machine. Be sure exposed personnel in the area of operation are clear of the machine before moving it or its attachments. Sound horn.
- Rust inhibitors are volatile and flammable Use only in well ventilated areas. Keep open flames away - DO NOT SMOKE - Store containers in a cool well ventilated place, secure against unauthorised personnel.
- Do not carry loose objects in pockets that might fall unnoticed into open compartments.
- Wear proper protective equipment such as safety goggles or safety glasses with side shields, hard hat, safety shoes, heavy gloves when metal or other particles are apt to fly or fall.
- Wear welders protective equipment such as dark safety glasses, helmets, protective clothing, gloves and safety shoes, when welding or burning. Wear dark safety glasses near welding zones.

SAFETY RULES

DO NOT LOOK AT ARC WITHOUT PROPER EYE PROTECTION.

- Know your jacking equipment and its capacity. Be sure the jacking point used on the machine is appropriate for the load to be applied. Be sure the support of the jack at the machine and under jack is appropriate and stable.
- The load lifted by jacks is always dangerous: it is necessary to transfer loads to appropriate blocking as a safety measure, before proceeding with service or maintenance work, according to local or national regulations.
- Steel cables are frayed after prolonged use; always wear appropriate protections (heavy gloves, goggles etc.).
- Handle all parts carefully. Keep hands and fingers away from structures, gears or moving parts. Use and wear always the appropriate protections
- Compressed air systems can have water deposits created by moisture condensation due to changes of atmospheric conditions. If required, discharge deposits, as instructed.

STARTING

- Do not run the engine in closed areas without proper ventilation to remove deadly exhaust fumes.
- Do not place head, body, limbs, feet, hands or fingers, near rotating fans or belts. Be especially alert near pusher fans.

ENGINE

- Loosen the radiator cap very slowly, to release pressure from the system, before removing it. All coolant level top-ups must be performed with engine OFF.
- Avoid that flammable materials touch exhaust parts. Should this be possible, provide the necessary protections.
- Do not run engine when refuelling and use care if the engine is hot due to the increased possibility of a fire if fuel is spilled.
- Never attempt to check or adjust fan belts when engine is running.
- Do not adjust engine fuel pump when machine is moving.

- Do not lubricate the machine with engine running.
- Do not run the engine with air intakes, door or protections open.

ELECTRICAL SYSTEM

- Disconnect batteries prior to any intervention on machine or electrical system (cleaning, repair, maintenance).
- Should booster batteries be used, remember to connect both ends of the booster cables in the proper manner (+ with (+) and (-) with (-). Avoid short-circuits of the terminals. Follow thoroughly the instructions of this Manual.
- Before any intervention, make sure that the main switch is OFF.
- BATTERY GAS IS HIGHLY FLAMMABLE. Leave battery box open to improve ventilation when recharging batteries. Never check charge by placing metal objects across the posts. Keep sparks or open flames away from batteries. Do not smoke near battery to guard against the possibility of causing an explosion.
- Before any intervention, make sure that there are no fuel or electrolyte leakages; eliminate them before proceeding with further work. When recharging batteries in closed ambients, make sure that there is appropriate ventilation to prevent possible accidental explosions due to the accumulation of gases generated during the recharge.

HYDRAULIC SYSTEM

- Fluid escaping under pressure from a very small hole can be almost invisible and can have sufficient force to penetrate the skin. Use a piece of cardboard or wood to search for suspected pressure leaks. DO NOT USE HANDS. If injured by escaping fluid, see a doctor at once. Serious infection or reaction can develop if proper medical treatment is not administered immediately.
- Stop the engine and release all pressures in the system before removing panels, housings, plugs or covers.
- In case pressures must be measured, use instruments of adequate capacity. Always follow the recommended procedures.

SAFETY RULES

TOOLS

- Keep head, body, limbs, feet, fingers or hands away from bucket, blade or ripper when in raised position.

Prior to any intervention, install all safety devices according to current rules and regulations.

- In case equipment on the machine must be operated by hydraulic systems, remember to proceed only after seating in the operator's compartment. Make sure that there are no persons in the operating area of the machine. Alert people before operating using the horn and by voice. Move the equipment very carefully.
- Do not use machine to transport loose objects, unless proper devices for this purpose are provided.

- Clutches and brakes of this machine and eventual auxiliary equipment and attachments (such as operating cylinder or winches control valves) must always be properly adjusted in accordance with the instructions provided by the Manuals of the Manufacturer.

- Never perform adjustments with engine running, except when called for by the above instructions.

When changing work shift, check that wheel or rim securing screws and brackets are not loosen; if necessary, retighten to the prescribed torque.



WARNING

On machines having hydraulically, mechanically, and/or cable controlled equipment (such as shovels, loaders, dozers, excavators etc.) be certain the equipment is lowered to the ground before servicing, adjusting and/or repairing. If it is necessary to have the hydraulically, mechanically, and/or cable controlled equipment partially or fully raised to gain access to certain items, be sure the equipment is suitably supported by means other than the hydraulic lift cylinders, cable and/or mechanical devices used for controlling the equipment.

SAFETY RULES

SAFETY RULES FOR SEALS

VITON SEALS (fluoroelastomer)

Seals, especially VITON O-Rings, (normally coloured red) are used in systems operating at high temperatures, since this material resists the effects of heat. However, in the event this material is subject to heat exceeding 315 °C (599 °F) (in practice, only in case of fire or when using welding flames) fluoridic acid is generated. **This acid is highly corrosive and could cause severe burns**, if in contact with the skin.

Every time it is necessary to intervene on components equipped with VITON rings, for which an exposure to excessive temperatures is suspected, the following procedures must be applied:

- 1) inspect visually, without touching them, all seals showing signs of damage due to high temperature. They look black and tacky;
- 2) identify the type of material of the seals, if they are VITON, performing the test illustrated below, on the spare parts;
- 3) in case it is verified, or there is a reasonable doubt that the components are made of VITON, the contaminated area **MUST** be decontaminated before proceeding with further operations;
- 4) wear neoprene rubber or PVC gloves and protection goggles or face screen, and wash accurately the contaminated zone with a solution of hydraulic lime (found at building stores) and water, so that a milky liquid is obtained. Rinse carefully with steam or running water;
- 5) dispose of the materials removed and the protective gloves in a safe manner, without burning them.

TEST FOR THE DISCRIMINATION OF RUBBER (BUNA N) MATERIALS AND "VITON" (FLUOROELASTOMER) MATERIAL

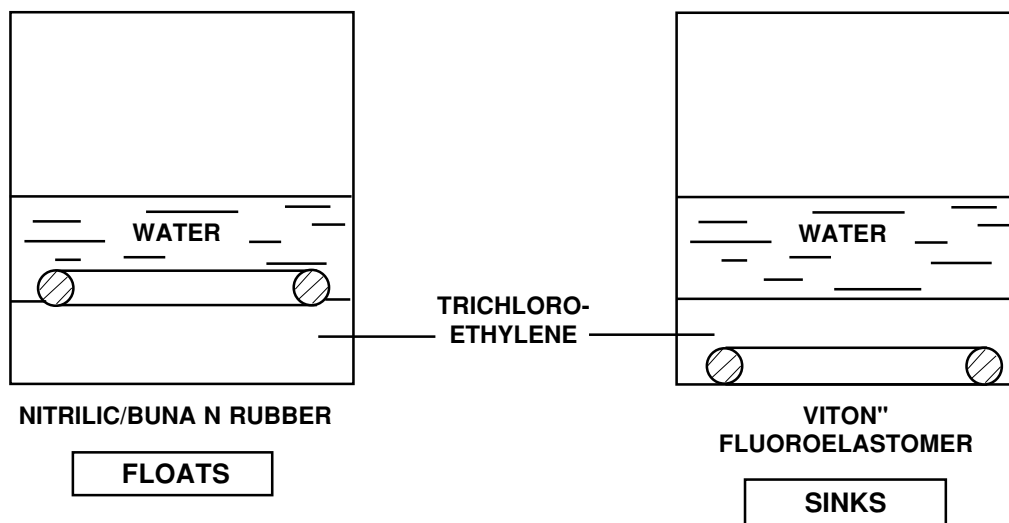

D180 Power Steering D180 LGP

DOZERS

TECHNICAL DATA TABLES

TABLE OF FLUID CAPACITIES

ITEM	QUANTITY (Litres)	Fluids and lubricants 	VISCOSITY GRADE	Outdoor temperatures of reference	International Classification
Cooling system	28 (30)	Agriflù	Agriflù mixed with 50 % water protects down to -35° C (-31° F)	Down to -35° C (-31° F)	Mixture of water and antifreeze at 50%. The mixture provides oxidation, foaming, corrosion, scaling and freezing protection properties down to -35° C (-31° F).
Fuel reservoir	400	-	-	-	DIESEL FUEL ASTM No. 2D Grade TT of reputable quality and make
Engine	16 (19)	Super Gold	SAE 15W - 40	-15 to 40° C (-5 to 104° F)	APICF-4/SG or CCMC D4 or MIL-L-2104E
			SAE 10W - 30	-25 to 20° C (-13 to 68° F)	
Torque converter Transmission	31 (40)	Hydropower	SAE 10W	All season	ATF Type A Suffix A
Transmission housing steering/brakes	46 (60)	Super Gold	SAE 15W - 40	-15 to 40° C (-5 to 100° F)	APICF-4/SG or CCMC D4 or MIL-L-2104E
			SAE 10W - 30	-25 to 20° C (-13 to 68° F)	
Hydraulic system "BULLDOZER" equipment D180 Power Steering D180LGP	90 (110) 110 (130) 110 (130)	HI-TECH 46	ISO 46	-20° C to 50° C (-4 to 122° F)	DIN 51524 PART - 1 DIN 51524 PART - 2 ISO VG 46
			SAE 80W - 90	All season	
Final drives (each)	33	Hypoide 90	SAE 15W - 40	-15 to 40° C (5 to 104° F)	API CE or CCMC D4 or MIL-L-2104E
Idlers Rollers and track chains	7	Super	SAE 10W - 30	-25 to 20° C (-13 to 68° F)	
Grease fittings		MG2	NLGI2 consistency	All season	-
Cab tilting pump	0.5	Hydropower	SAE 10W	All season	ATF Type A Suffix A

Note: Oil quantities indicated are those required for periodical changes.
- () First supply quantity.

If the content of sulphur of the fuel exceeds 0.5 %, change the engine oil as follows:

Down to 0.5 % sulphur	Periodical change
from 0.5 to 1 %	Half normal interval
Over 1 %	One quarter normal interval

MAIN DIMENSIONS D180 Power Steering

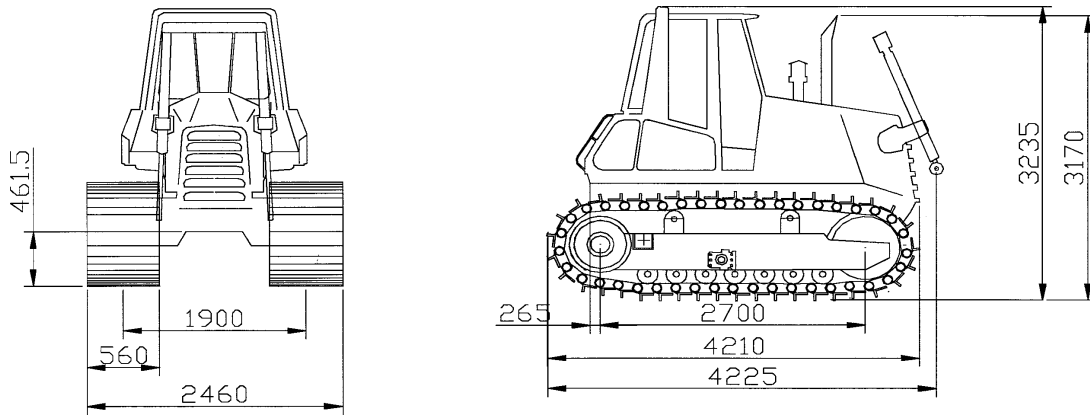

BULDOZER HSU + RIPPER

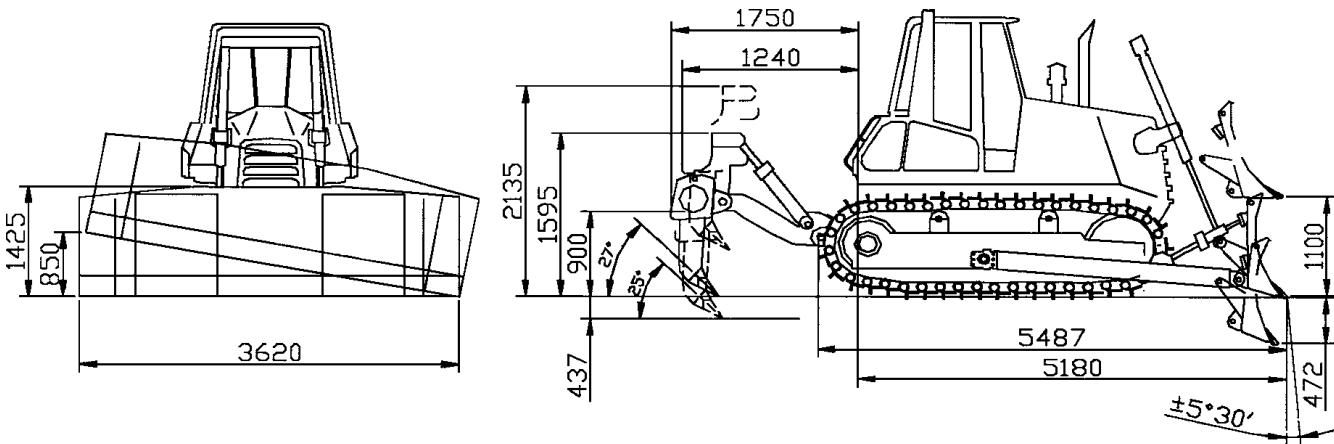

ANGLED OZER

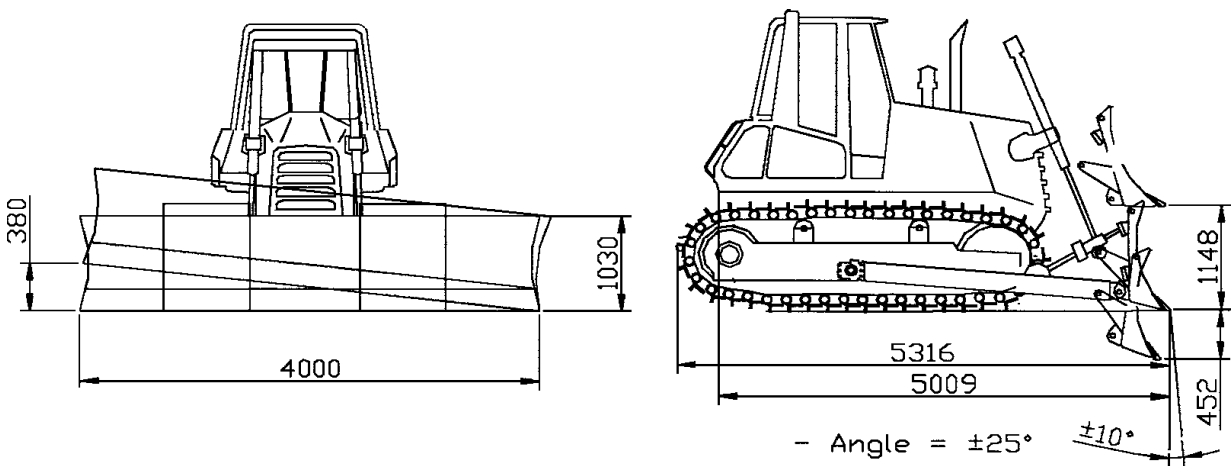

MAIN DIMENSIONS D180 LGP

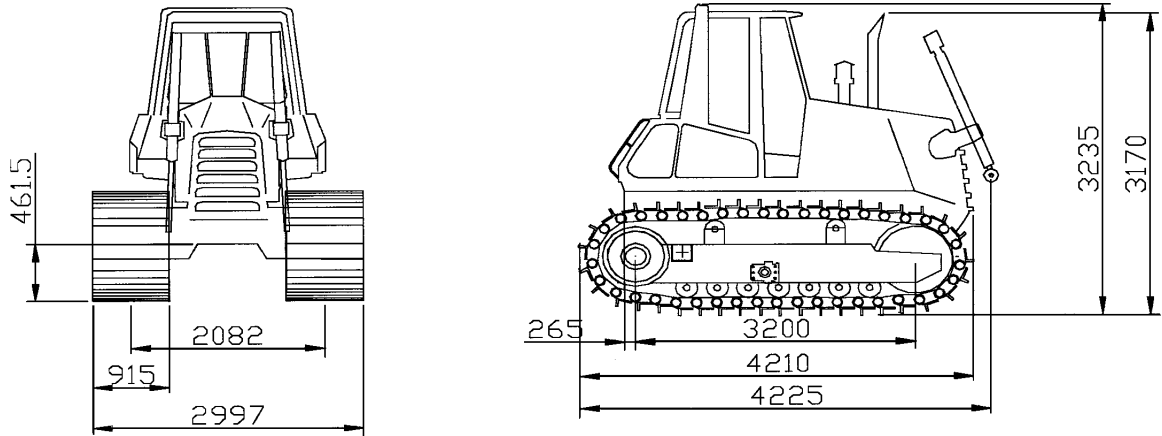

BULLDOZER HS + RIPPER

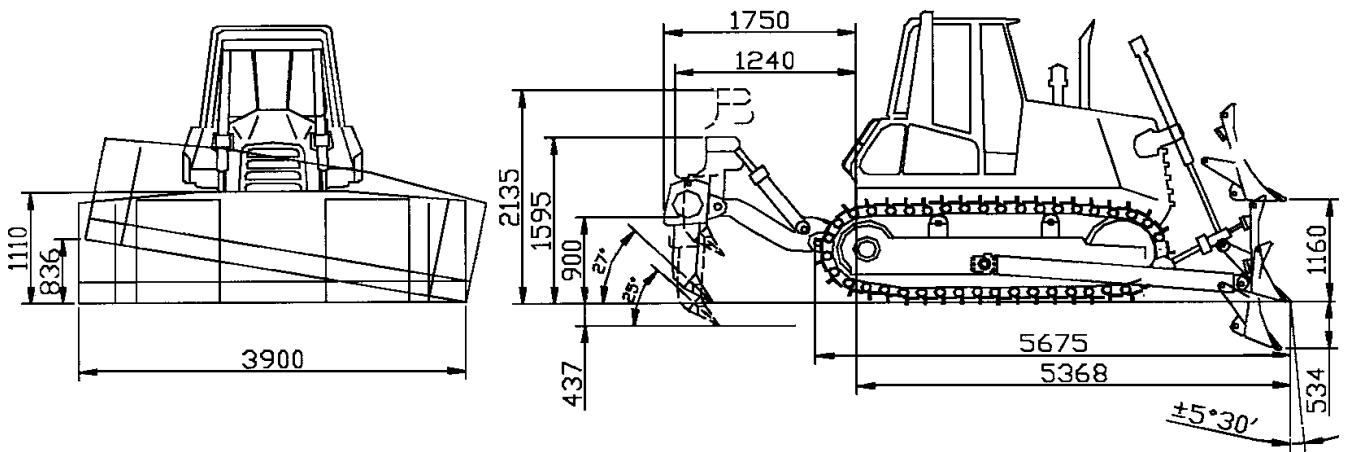

TECHNICAL DATA D180 Power Steering/LGP

MACHINE MODEL	FHE MODEL CODE NUMBER	Power Steering LGP	625.996.00.1 625.997.00.1	
DIMENSIONS	Length Bare tractor (560 mm shoes) With semi-U blade With straight blade With angledozer blade	mm (in)	4210 (165.75) 5487 (216.02) 5295 (208.46) 5316 (209.29)	
	Width Bare tractor (560 mm shoes) With semi-U blade With straight blade With angledozer blade	mm (in)	2460 (96.83) 3620 (142.52) 3384 (133.22) 4000 (157.48)	
	Height To top of exhaust pipe To top of ROPS cab	mm (in)	3170 (124.80) 3235 (127.36)	
	Gauge Ground clearance Length of track chain on ground Width of track chain (std)	mm (in)	1900 (74.80) 390 (15.35) 2700 (106.29) 560 (22.04)	
	MASSES	Mass at shipment (with ROPS cab, 560 mm shoes lubricants, coolant, 10% fuel)	kg (lbs)	16940 (37,268)
		Mass in operating conditions with ROPS cab, 560 mm shoes, semi-U blade lubricants, coolant, 100% fuel, operator)	kg (lbs)	20180 (44,396)
		LGP mass at shipment (with ROPS cab, 915 mm shoes lubricants, coolant, 10% fuel)	kg (lbs)	19400 (42,680)
		Mass in operating conditions with ROPS cab, 915 mm shoes, HS blade lubricants, coolant, 100% fuel, operator)	kg (lbs)	22720 (49,984)
	PERFORMANCES	Max. speeds FORWARD 1st 2nd 3rd	km/h (mph)	4.1 (2.54) 6.8 (4.21) 10.6 (6.57)
		REVERSE 1st 2nd 3rd	km/h (mph)	5.1 (3.16) 8.3 (5.14) 12.6 (7.81)

Carefully read personal and machine SAFETY PRECAUTIONS at the beginning of this Manual