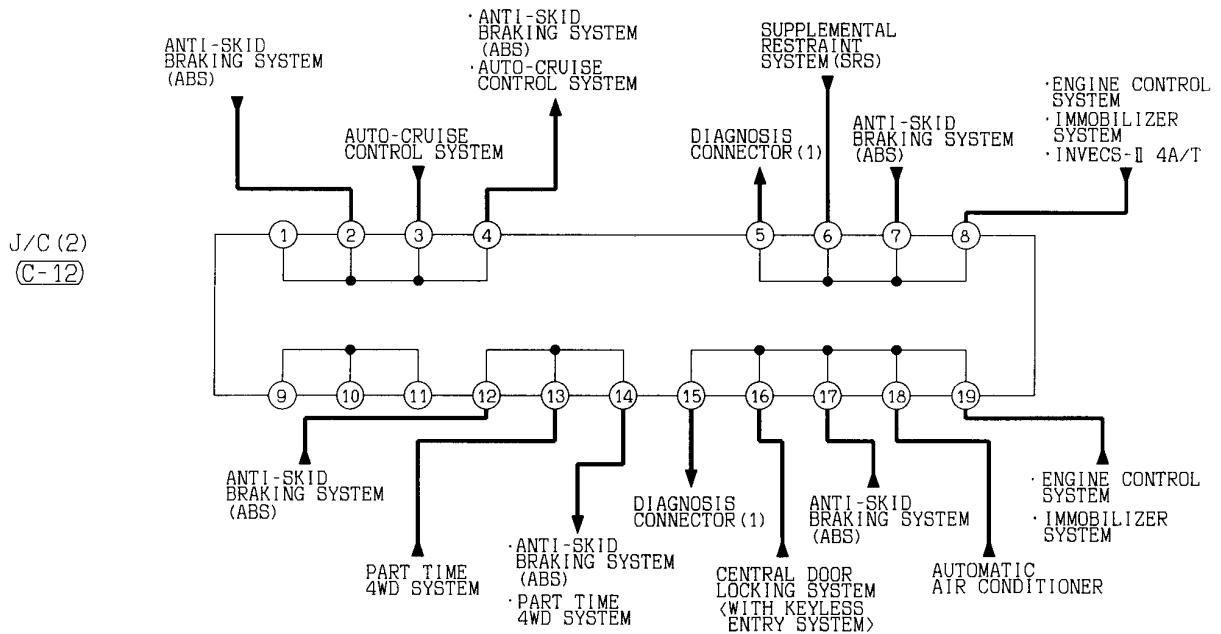
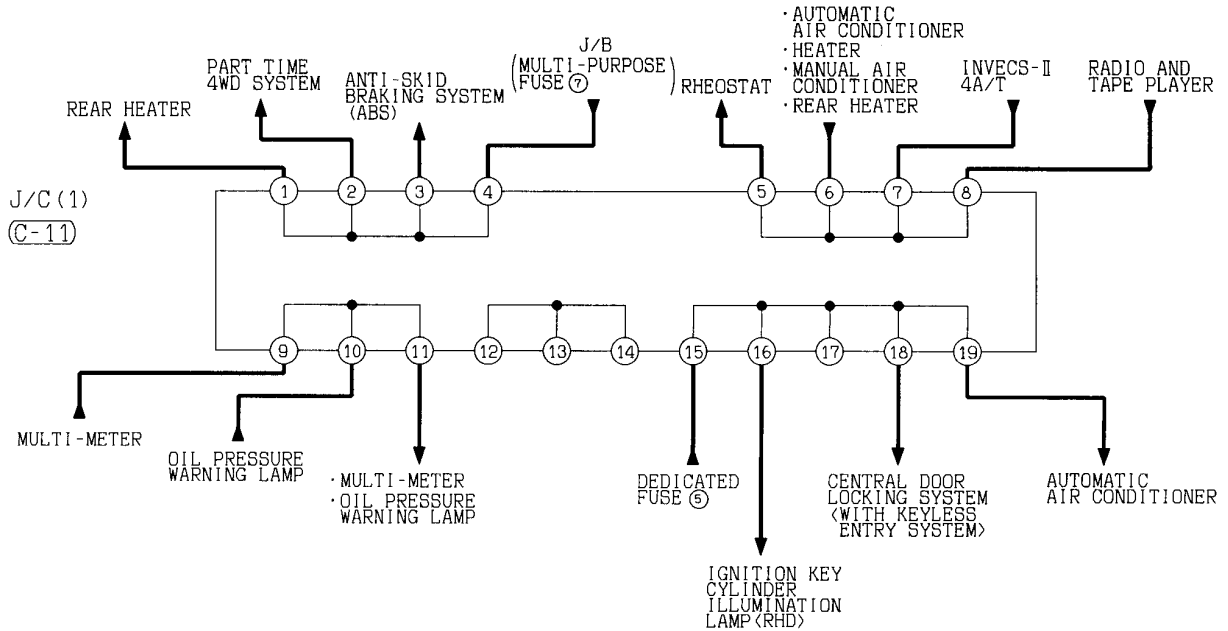

CIRCUIT DIAGRAMS

CONTENTS

JOINT CONNECTOR (J/C)	2	OIL PRESSURE WARNING LAMP	65
POWER DISTRIBUTION SYSTEM		FUEL FILTER WARNING LAMP	
L.H. drive vehicles	6	Diesel-powered vehicles	65
R.H. drive vehicles	12	MULTI-METER	66
STARTING SYSTEM		MANUAL AIR CONDITIONER	
M/T	18	Except diesel-powered vehicles <Step II>	68
ENGINE CONTROL SYSTEM		AUTOMATIC AIR CONDITIONER	74
MPI-M/T	20	AUTO-CRUISE CONTROL SYSTEM	82
MPI-A/T	30	IMMOBILIZER SYSTEM	
Diesel <Step II>	40	Petrol-powered vehicles	88
Diesel <Step III>	42	Diesel-powered vehicles <Step III>	90
INVECS-II 4A/T	50	INTERCOOLER FAN	
METER AND GAUGE	60	Diesel-powered vehicles <Step II>	92
ENGINE OIL LEVEL WARNING LAMP		Diesel-powered vehicles <Step III>	93
Diesel-powered vehicles	63	FUEL LINE HEATER	94
BRAKE WARNING LAMP	64		
FUEL WARNING LAMP	64		

JOINT CONNECTOR (J/C)

NOTE
 IN ACTUAL VEHICLES, ANY OF THE TERMINALS CONNECTED IN J/C ARE USED.
 THE TERMINAL ARRANGEMENT DESCRIBED IN THE CIRCUIT DIAGRAM MAY NOT BE
 IDENTICAL TO THOSE OF THE VEHICLES.



(C-11)

MU801559	1	2	3	4	5	6	7	8			
	9	10	11	12	13	14	15	16	17	18	19

(C-12)

MU801559	1	2	3	4	5	6	7	8			
	9	10	11	12	13	14	15	16	17	18	19

(C-68)

	1	2	3	4	5	6	7	8	9	10	11
	12	13	14	15	16	17	18	19	20	21	22
	23	24	25	26	27	28	29	30	31	32	33

(C-71)

	1	2	3	4	5	6	7	8	9	10	11
	12	13	14	15	16	17	18	19	20	21	22
	23	24	25	26	27	28	29	30	31	32	33

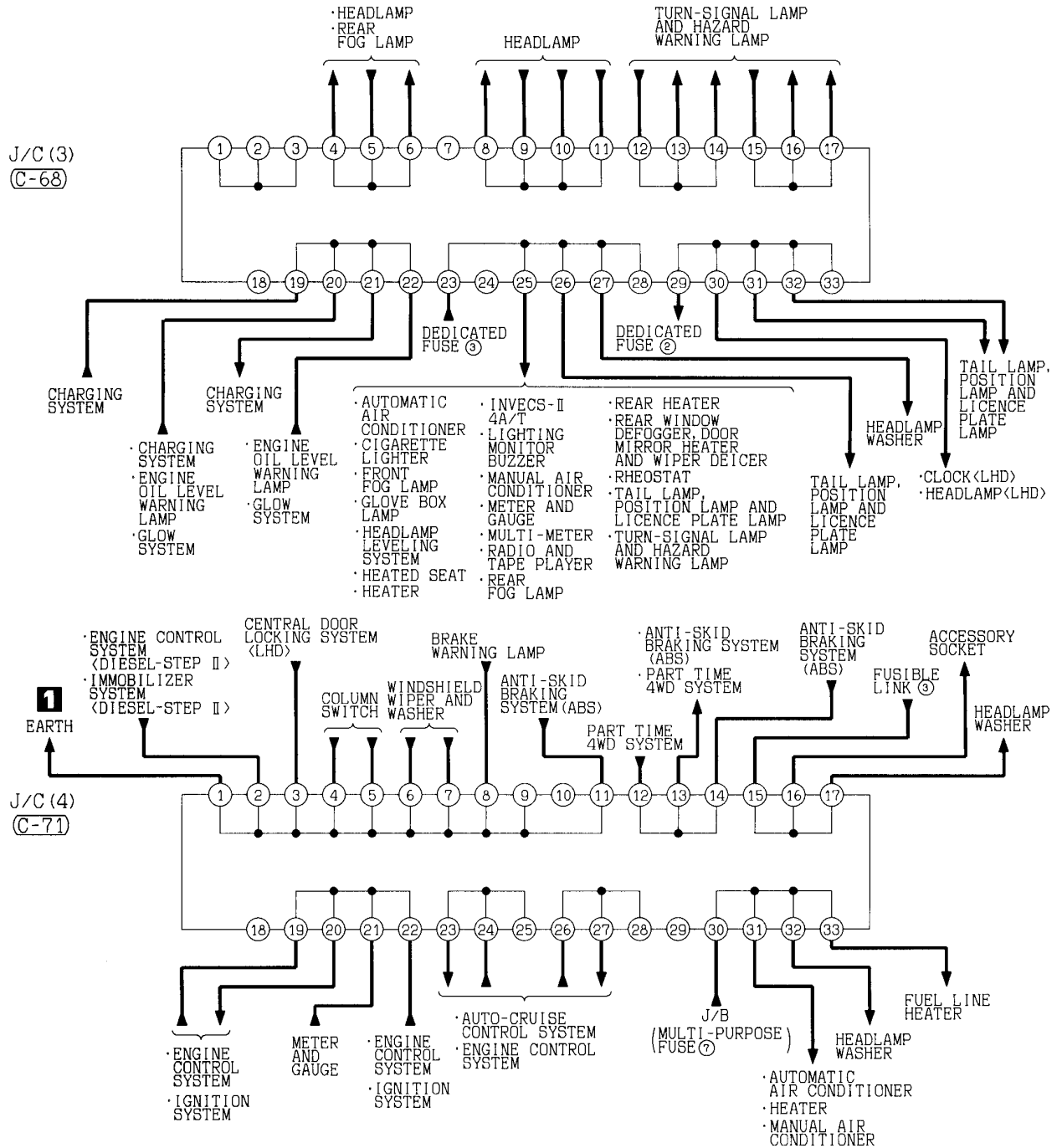

JOINT CONNECTOR (J/C) (CONTINUED)

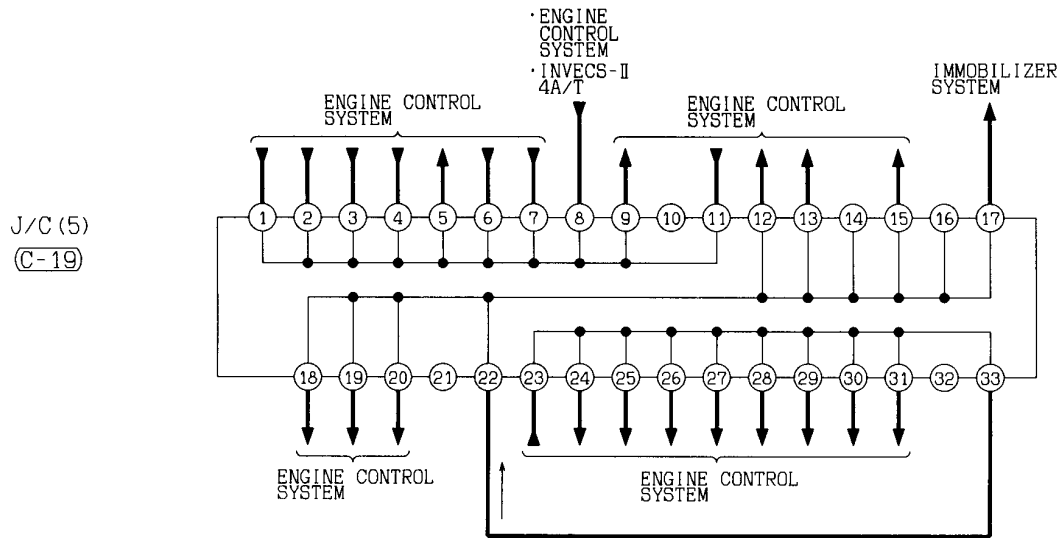

(C-19)

1	2	3	4	5	6	7	8	9	10	11
12	13	14	15	16	17	18	19	20	21	22
23	24	25	26	27	28	29	30	31	32	33

NOTES

POWER DISTRIBUTION SYSTEM

L.H. drive vehicles

1

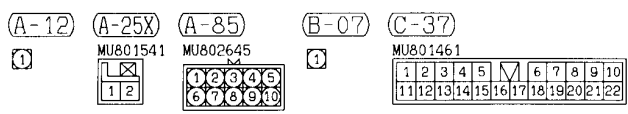
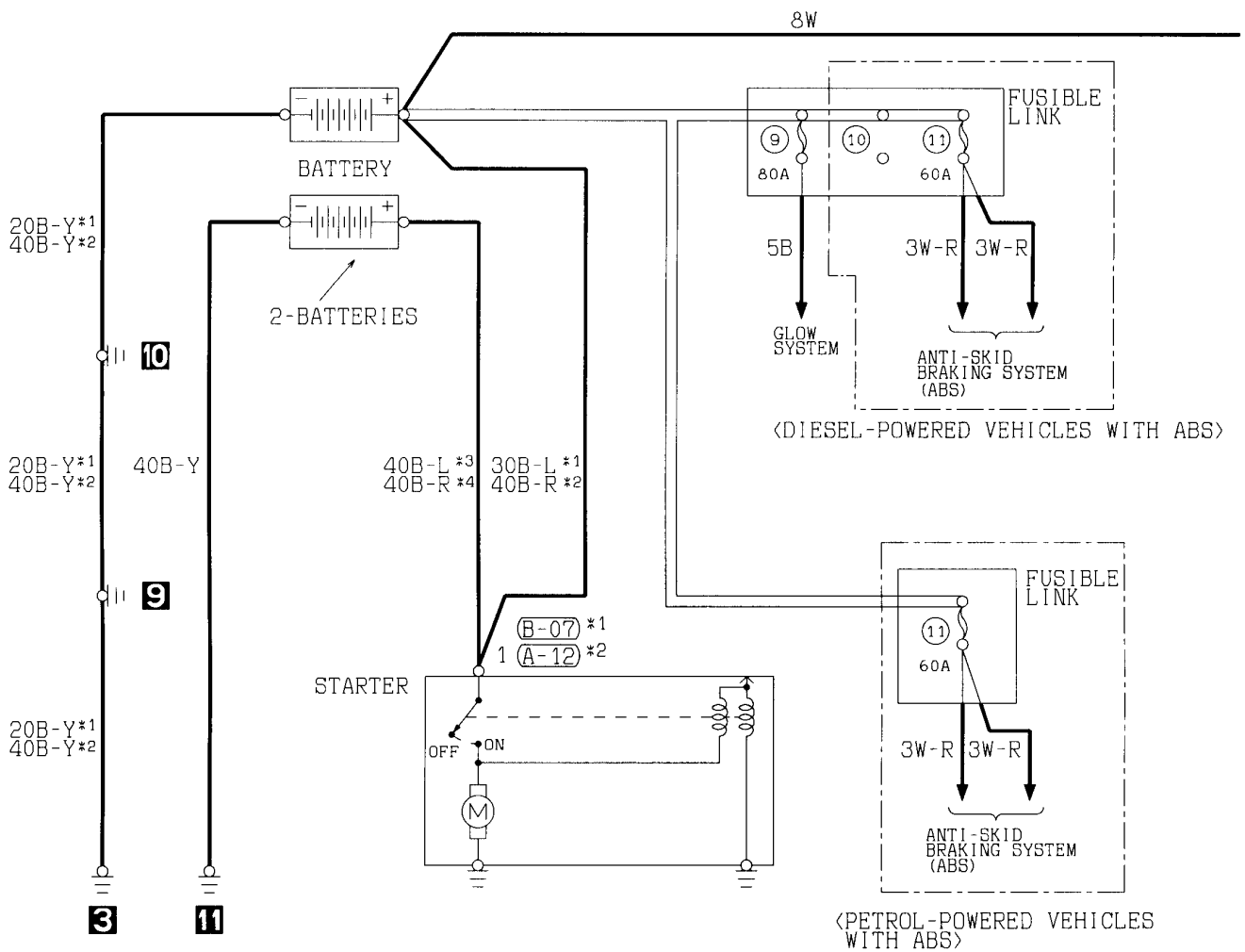

NOTE
 *1: PETROL
 *2: DIESEL
 *3: DIESEL (STEP III)
 *4: DIESEL (STEP II)

2

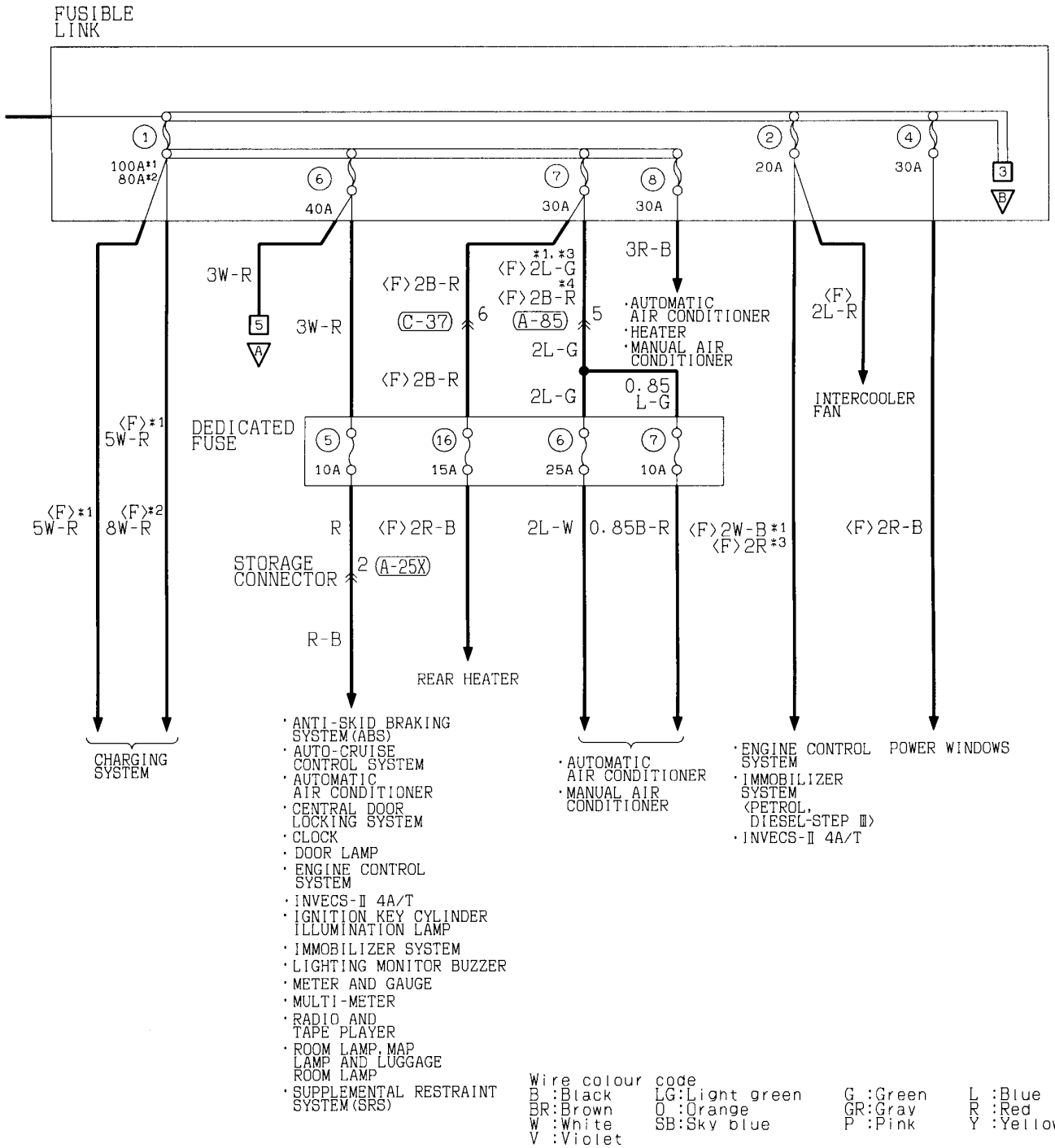

POWER DISTRIBUTION SYSTEM <L.H. drive vehicles> (CONTINUED)

3

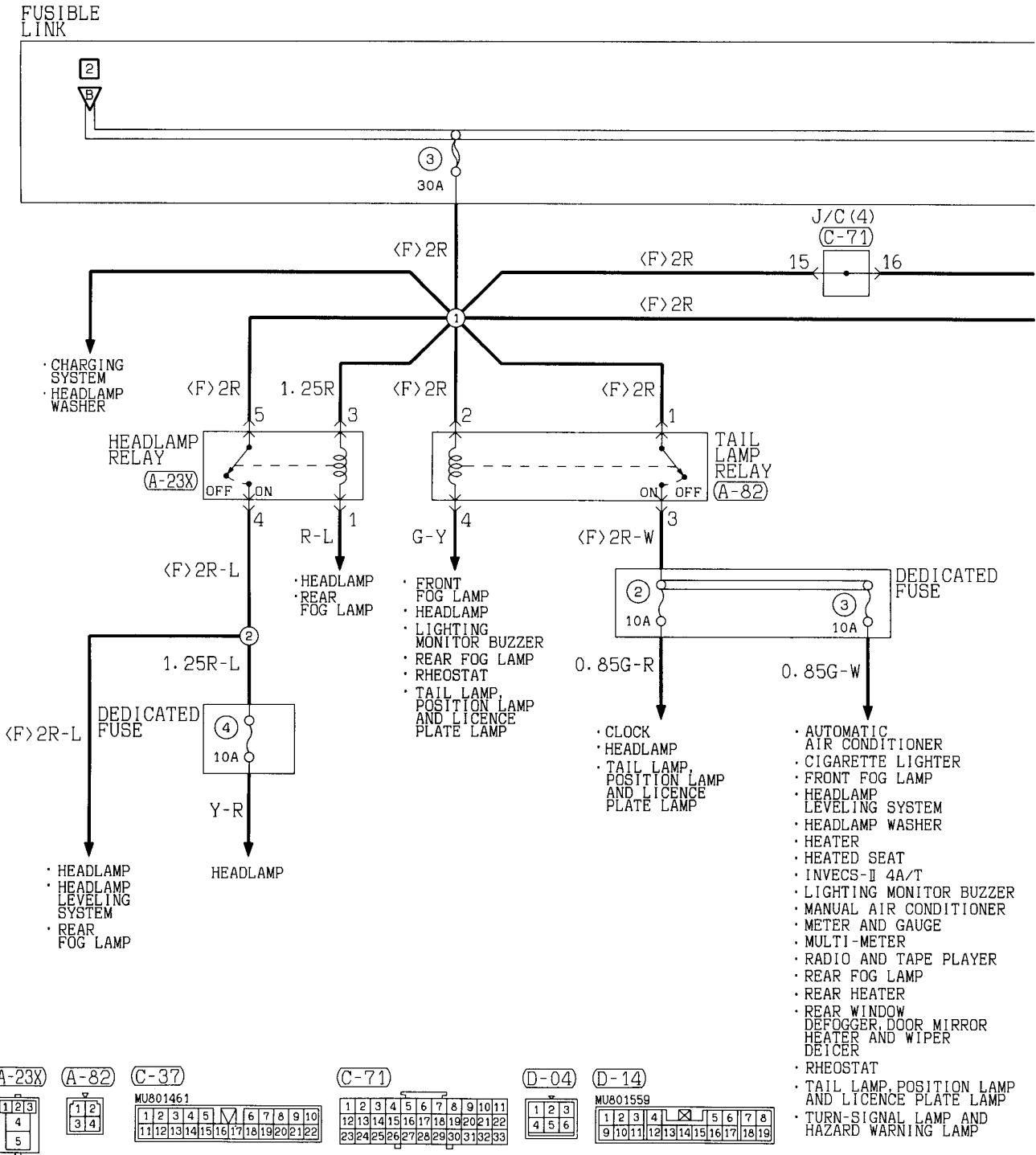

4

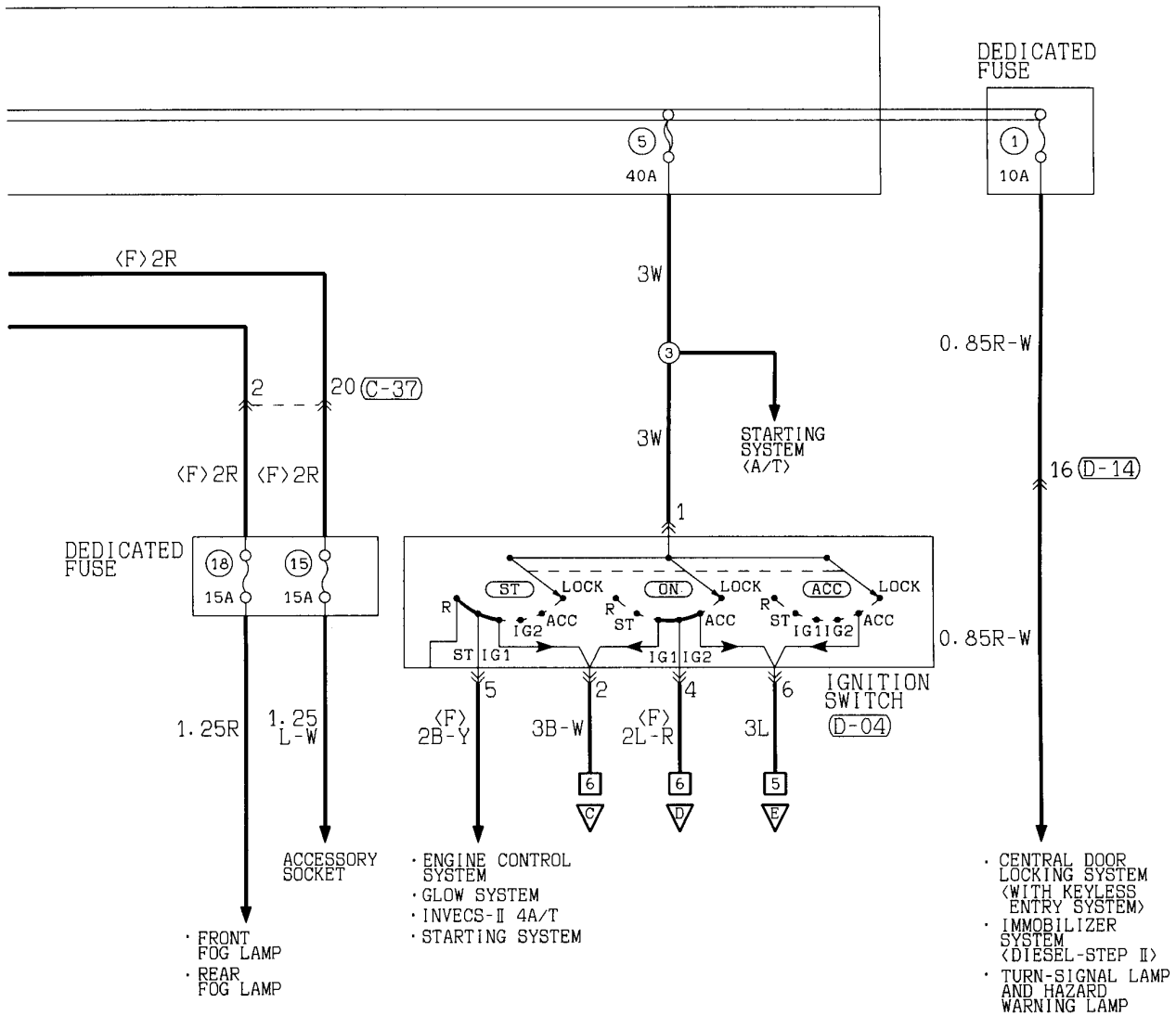

NOTE
THE ABOVE CIRCUIT DIAGRAM SHOWS THE CURRENT FLOW AT THE IGNITION KEY POSITION "ACC", "ON" AND "ST" COMBINED. BE SURE TO TRACE THE APPROPRIATE CIRCUIT DEPENDING ON THE IGNITION KEY POSITION.

Wire colour code
 B :Black LG:Light green G:Green L :Blue W :White Y :Yellow SB:Sky blue
 BR:Brown O :Orange GR:Gray R :Red P :Pink V :Violet

H2P01E02BB