

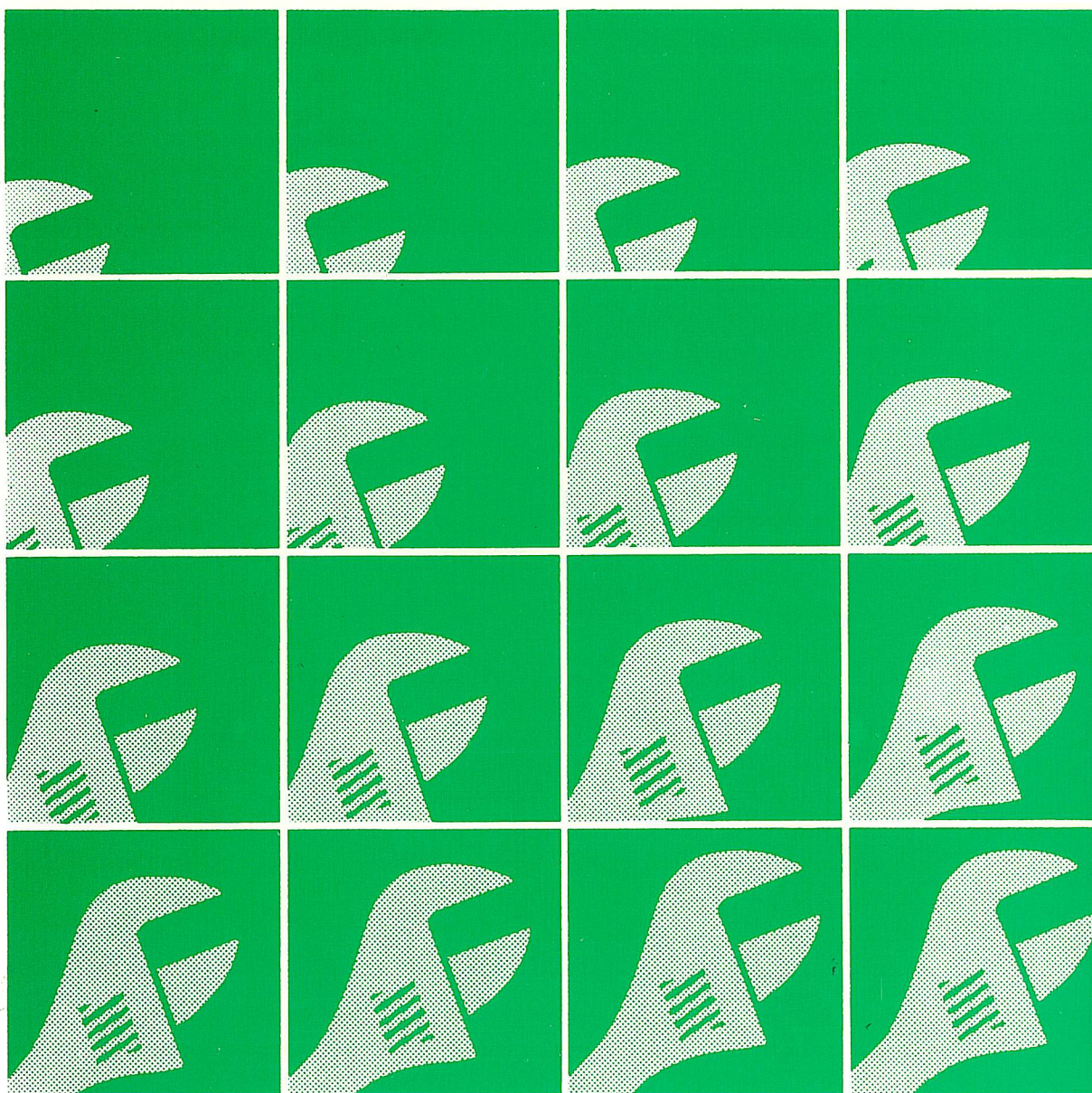

Service Manual

FK.FM



Pub. No. TWME8514

FK.FM

Service Manual

FOREWORD

This service manual contains the instructions for the servicing of the Mitsubishi Fuso FK, FM series trucks. Please make the most of this service manual to perform correct servicing and wasteless operations. Note that some of the contents of this service manual are subject to change owing to improvements, etc. that may be introduced after publication of the service manual.

For more details, consult your local Mitsubishi Fuso Dealers and Distributors.

December 1985

GROUP INDEX

GENERAL	00
MAINTENANCE SCHEDULE	01
ENGINE	11
LUBRICATION	12
FUEL	13
COOLING	14
INTAKE AND EXHAUST	15
ENGINE ELECTRICAL	16
CLUTCH	21
TRANSMISSION	22
PROPELLER SHAFT	25
FRONT AXLE	26
REAR AXLE	27
WHEEL AND TIRE	31
FRONT SUSPENSION	33
REAR SUSPENSION	34
BRAKE	35
STEERING	37
FRAME	41
CAB	42
CHASSIS ELECTRICAL	54
HEATER	55
ALPHABETICAL INDEX	

COMPILATION OF THIS MANUAL – GROUP CLASSIFICATION

1. GROUP CLASSIFICATION

This manual is organized into groups as follows:

Group No.	Group Name	Contents
00	General	Exterior views, specifications, power train table, operation performance curves, engine performance curves, servicing precautions, vehicle identification number, standard bolts and nuts tightening torque table
01	Maintenance schedule	Maintenance schedule table, simple maintenance procedures, lubrication chart, simple lubrication procedures
11	Engine	Engine proper (cylinder head, valve mechanism, camshaft, piston, crankshaft, timing gear, flywheel), air compressor, flywheel PTO. Specifications, service standards, special tools, troubleshooting.
12	Lubrication	Lubrication system (oil pump, oil filter, oil cooler). Specifications, service standards, special tools, troubleshooting.
13	Fuel	Fuel system (injection pump, injection nozzle, fuel filter, water separator), engine control (accelerator pedal, fuel control, stop button). Specifications, service standards, special tools, troubleshooting.
14	Cooling	Cooling system (water pump, thermostat, radiator, fan). Specifications, service standards, special tools, troubleshooting.
15	Intake and exhaust	Air cleaner, turbocharger, manifold Specifications, service standards, special tools, troubleshooting.
16	Engine electrical	Starter, alternator Specifications, service standards, special tools, troubleshooting.
21	Clutch	Clutch proper, clutch control (master cylinder, clutch booster). Specifications, service standards, special tools, troubleshooting.
22	Transmission	Transmission proper, gear shifter, case, transmission control, (power shift,) transmission PTO. Specifications, service standards, troubleshooting.
25	Propeller shaft	Propeller shaft, center bearing, universal joint. Specifications, service standards, special tools, troubleshooting.
26	Front axle	Front axle, king pin, knuckle, hub bearing. Specifications, service standards, special tools, troubleshooting.
27	Rear axle	Rear axle, reduction and differential, hub bearing. Specifications, service standards, special tools, troubleshooting.
31	Wheel and tire	Specifications, service standards, special tools, troubleshooting.
33	Front suspension	Front suspension, leaf spring, shock absorber. Specifications, service standards, special tools, troubleshooting.
34	Rear suspension	Rear suspension, leaf spring. Specifications, service standards, special tools, troubleshooting.
35	Brake	Service brake [dual brake valve, brake booster, wheel brake (wheel cylinder, brake drum, brake shoe)], parking brake (brake drum, brake shoe, parking brake control), exhaust brake (exhaust brake valve, control cylinder). Specifications, service standards, special tools, troubleshooting.
37	Steering	Steering wheel, power steering booster, power steering oil pump, steering linkage, tie rod. Specifications, service standards, special tools, troubleshooting.
41	Frame	Frame. Specifications.
42	Cab	Body, window glass, door, seat. Specifications
54	Chassis electrical	Meter, gauge, switch, lamp, warning and indicator lamp, wiper. Specifications.
55	Heater	Heater, ventilation system. Specifications.

NOTE:

Each group starts with page 1.

COMPILATION OF THIS MANUAL – DEFINITION OF TERMS AND UNIT USED

2. DEFINITION OF TERMS AND UNIT USED

Throughout the entire text of this manual, the following terms are used to mean specifically as detailed below.

Front and Rear

“Front” is the forward direction of the vehicle; “rear” the backward direction.

Right and Left

All instructions, as they are related to “right” or “left” of the vehicle, are based on the vehicle facing in the forward direction.

Nominal Value (Abbr.: NV):

Shows the nominal dimension used in designing, designed dimension of individual parts, standard clearance between assembled parts, or the standard performance of an assembly.

Basic Diameter (Abbr.: BD):

Shows the basic diameter used in designing.

In SERVICE STANDARDS, the value is shown in [].

Service Limit (Abbr.: SL):

Shows the limit dimension and value of a part, at which the part is no longer serviceable from performance as well as strength viewpoints and requires replacement.

Repair Limit (Abbr.: RL):

Shows the limit of clearance between parts or limit dimension of a part, at which the part requires repair. For the engine, the value is also indicated when requiring repair for selection of oversize or undersize and of shim thickness.

Tightening Torque

Tightening the bolts and nuts to specification is extremely important to ensure proper performance and function and a tightening torque value is specified for particular tightening points.

Unless specified as “wet”, all points must be tightened in dry state.

Where no tightening torque value is given, use the tightening torque for general bolts and nuts shown in Table elsewhere.

Unit

Length, weight, area and volume are indicated by SI units (foot-pound and metric units in parentheses). Temperature is indicated by Centigrade °C (Fahrenheit °F in parentheses).

COMPILATION OF THIS MANUAL – NOTES ON ILLUSTRATIONS

3. NOTES ON ILLUSTRATIONS

Example 1 Disassembly

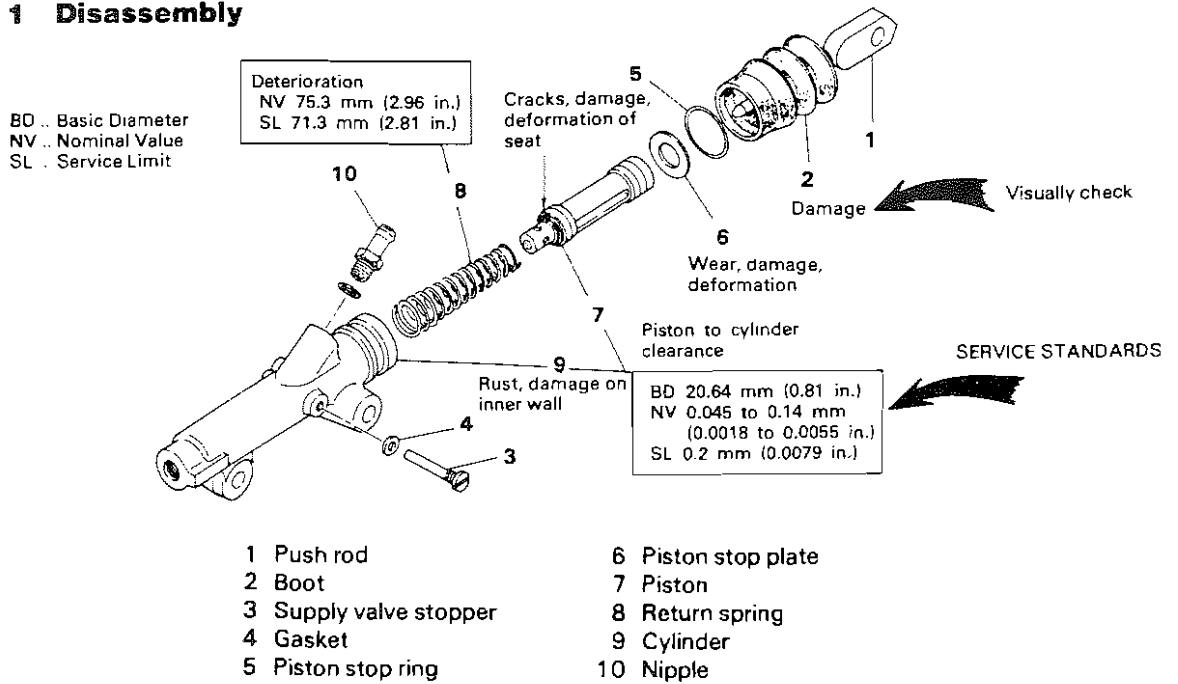

E0231A

COMPILATION OF THIS MANUAL – NOTES ON ILLUSTRATIONS

Example 2 Assembly

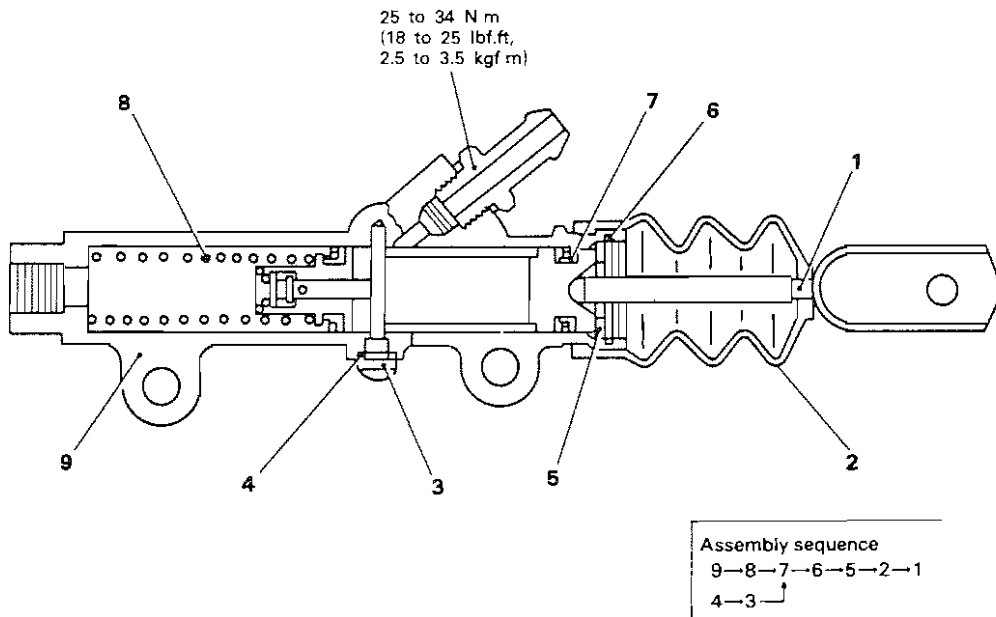

E0002A

Notations enclosed with a frame in the illustrations indicate service items based on the service standards; those not enclosed by a frame, the visual inspection items to be performed during disassembly.

Numbers shown in the disassembled view serve as an example of disassembly sequence.

The "assembly sequence" shown in the assembly drawing (plan view) is an example of assembly order. Only a typical equipment illustration (disassembled view, assembly drawing, etc.) is given regardless of availability of type variations if there is only one applicable service procedure.

4. Asterisked (*) special tools shown in this manual are not included in the Special Service Tool Package prepared by OWATONNA TOOL COMPANY.

Please note that some of the special tools contained in the package slightly differ from those shown in this manual in part number, shape, size and use. For detail information, refer to the Special Service Tool Manual published as a separate volume.

GENERAL

CONTENTS

1. EXTERIOR VIEWS	2	6. SERVICING PRECAUTIONS	15
2. MAJOR SPECIFICATIONS	3	7. VEHICLE IDENTIFICATION	
3. POWER TRAIN TABLE	8	NUMBER	18
4. EQUIPMENT MODEL		8. STANDARD BOLTS AND NUTS	
NOTATION	9	TIGHTENING TORQUE TABLE	20
5. PERFORMANCE CURVES	10		
5.1 OPERATION PERFORMANCE			
CURVES	10		
5.2 ENGINE PERFORMANCE			
CURVES	14		

1. EXTERIOR VIEWS

FK415J

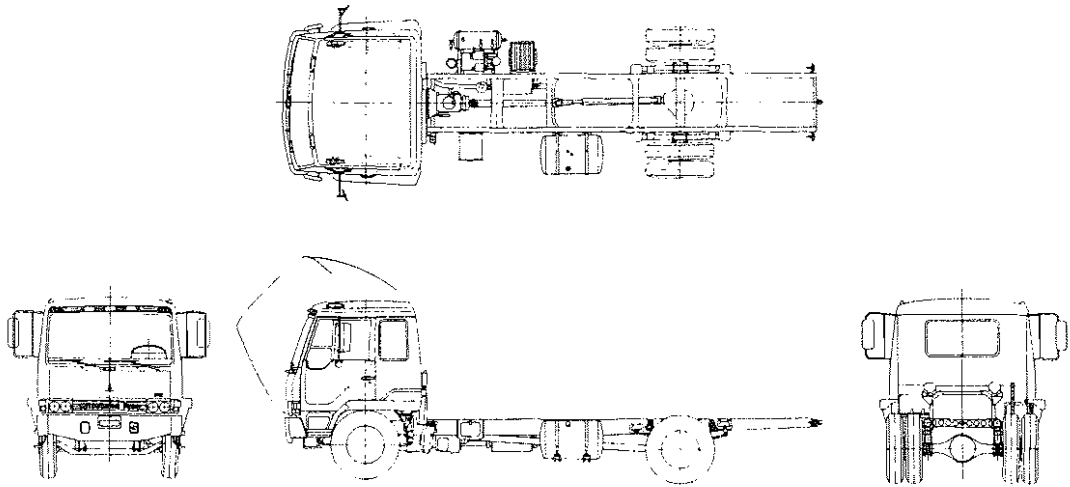

FK455J

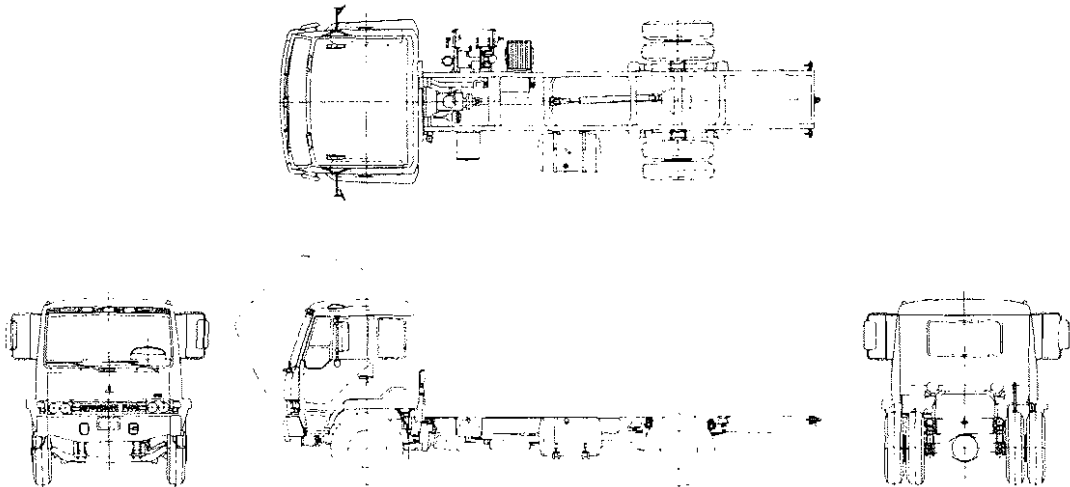

FM555L

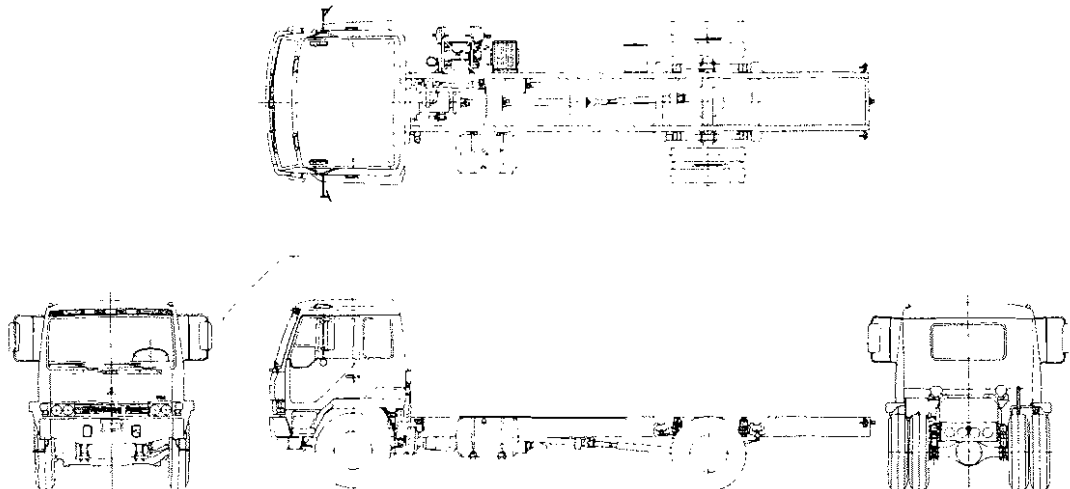

2. MAJOR SPECIFICATIONS

Item	Model	FK415H	FK415J	FK415K
Type		Forward control type		
Drive system		4 x 2		
Dimensions	mm (in.)			
Wheel base		4 210 (165.7)	4 510 (177.6)	4 810 (189.4)
Overall length		7 275 (286.4)	7 710 (303.5)	8 150 (320.9)
Overall width		2 370 (93.3)	2 370 (93.3)	2 370 (93.3)
Overall height approx.		2 615 (103.0)	2 615 (103.0)	2 615 (103.0)
Tread	Front	1 745 (68.7)	1 745 (68.7)	1 745 (68.7)
	Rear	1 725 (67.9)	1 725 (67.9)	1 725 (67.9)
Weight	kg (lbs.)			
Vehicle weight		3 440 (7 580)	3 455 (7 615)	3 470 (7 650)
Gross vehicle weight Max. GVW		10 450 (23 000)	10 450 (23 000)	10 450 (23 000)
Seating capacity		2	2	2
Performance (Computed)				
Max. Speed	km/h (mph)	112 (70)	112 (70)	112 (70)
Climbing ability with Max. GVW	(tan θ)	26%	26%	26%
Min. turning radius	m (ft.)	7.7 (25.3)	8.2 (26.9)	8.7 (28.5)

GENERAL – MAJOR SPECIFICATIONS

Item	Model	FK455H	FK455J	FK455K	FK455L
Type		Forward control type			
Drive system		4 x 2			
Dimensions	mm (in.)				
Wheel base		4 160 (163.8)	4 460 (175.6)	4 760 (187.4)	5 200 (204.7)
Overall length		7 275 (286.4)	7 710 (303.5)	8 150 (320.9)	8 900 (350.4)
Overall width		2 370 (93.3)	2 370 (93.3)	2 370 (93.3)	2 370 (93.3)
Overall height approx.		2 655 (104.5)	2 655 (104.5)	2 655 (104.5)	2 655 (104.5)
Tread	Front	1 900 (74.8)	1 900 (74.8)	1 900 (74.8)	1 900 (74.8)
	Rear	1 725 (67.9)	1 725 (67.9)	1 725 (67.9)	1 725 (67.9)
Weight	kg (lbs.)				
Vehicle weight		3 730 (8 225)	3 750 (8 265)	3 775 (8 320)	3 895 (8 585)
Gross vehicle weight Max. GVW		12 700 (28 000)	12 700 (28 000)	12 700 (28 000)	12 700 (28 000)
Seating capacity		2	2	2	2
Performance (Computed)					
Max. Speed	km/h (mph)	114 (71)	114 (71)	114 (71)	114 (71)
Climbing ability with Max. GVW	(tan θ)	27.5%	27.5%	27.5%	27.5%
Min. turning radius	m (ft.)	7.1 (23.3)	7.6 (24.9)	8.0 (26.2)	8.5 (27.9)

GENERAL – MAJOR SPECIFICATIONS

00

Item	Model	FM555F	FM555H	FM555J	FM555L	FM555M
Type		Forward control type				
Drive system		4 x 2				
Dimensions	mm (in.)					
Wheel base		3 680 (144.9)	4 280 (168.5)	4 620 (181.9)	5 080 (200.0)	5 550 (218.5)
Overall length		6 680 (263.0)	7 510 (295.7)	8 000 (315.0)	8 680 (341.7)	9 380 (369.3)
Overall width		2 420 (95.3)	2 420 (95.3)	2 420 (95.3)	2 420 (95.3)	2 420 (95.3)
Overall height approx.		2 685 (105.7)	2 685 (105.7)	2 685 (105.7)	2 685 (105.7)	2 685 (105.7)
Tread	Front	1 920 (75.6)	1 920 (75.6)	1 920 (75.6)	1 920 (75.6)	1 920 (75.6)
	Rear	1 815 (71.5)	1 815 (71.5)	1 815 (71.5)	1 815 (71.5)	1 815 (71.5)
Weight	kg (lbs.)					
Vehicle weight		4 175 (9 205)	4 245 (9 360)	4 285 (9 445)	4 355 (9 600)	4 425 (9 755)
Gross vehicle weight Max. GVW		14 800 (32 600)	14 800 (32 600)	14 800 (32 600)	14 800 (32 600)	14 800 (32 600)
Seating capacity		2	2	2	2	2
Performance (Computed)						
Max. Speed	km/h (mph)	103 (64)	103 (64)	103 (64)	103 (64)	103 (64)
Climbing ability with Max. GVW	(tan θ)	26.0%	26.0%	26.0%	26.0%	26.0%
Min. turning radius	m (ft.)	6.7 (22.0)	7.7 (25.3)	8.2 (26.9)	8.9 (29.2)	9.8 (32.2)

GENERAL – MAJOR SPECIFICATIONS

Item	Model	FM555F 10 speed transmission	FM555H 10 speed transmission	FM555J 10 speed transmission	FM555L 10 speed transmission	FM555M 10 speed transmission
Type		Forward control type				
Drive system		4 x 2				
Dimensions	mm (in.)					
Wheel base		3 680 (144.9)	4 280 (168.5)	4 620 (181.9)	5 080 (200.0)	5 550 (218.5)
Overall length		6 680 (263.0)	7 510 (295.7)	8 000 (315.0)	8 680 (341.7)	9 380 (369.3)
Overall width		2 420 (95.3)	2 420 (95.3)	2 420 (95.3)	2 420 (95.3)	2 420 (95.3)
Overall height approx.		2 685 (105.7)	2 685 (105.7)	2 685 (105.7)	2 685 (105.7)	2 685 (105.7)
Tread	Front	1 920 (75.6)	1 920 (75.6)	1 920 (75.6)	1 920 (75.6)	1 920 (75.6)
	Rear	1 815 (71.5)	1 815 (71.5)	1 815 (71.5)	1 815 (71.5)	1 815 (71.5)
Weight	kg (lbs.)					
Vehicle weight		4 330 (9 545)	4 405 (9 710)	4 440 (9 790)	4 505 (9 930)	4 580 (10 095)
Gross vehicle weight Max. GVW		14 800 (32 600)	14 800 (32 600)	14 800 (32 600)	14 800 (32 600)	14 800 (32 600)
Seating capacity		2	2	2	2	2
Performance (Computed)						
Max. Speed	km/h (mph)	111 (69)	111 (69)	111 (69)	111 (69)	111 (69)
Climbing ability with Max. GVW	(tan θ)	35.0%	35.0%	35.0%	35.0%	35.0%
Min. turning radius	m (ft.)	6.7 (22.0)	7.7 (25.3)	8.2 (26.9)	8.9 (29.2)	9.8 (32.2)

GENERAL – MAJOR SPECIFICATIONS

00

	Model	FK415	FK455	FM555	FM555 (10-speed transmission)
Engine		6D14 Water-cooled 4-cycle direct injection diesel engine	6D14T Water-cooled 4-cycle direct injection diesel engine with turbocharger		
Maximum output (SAE, Gross)	hp/rpm	157/3 000	185/2 900		
Maximum torque (SAE, Gross)	lbf.ft./rpm	307/1 800	408/1 800		
Clutch		C5W33 Hydraulic control, coil spring type, single dry plate	C6W35 Hydraulic control, coil spring type, single dry plate with air pressure assistance		
Transmission		M5S5 5-forward and 1-reverse speeds, 1st and reverse by constant-mesh type	M6S5 5-forward and 1-reverse speeds, 1st and reverse by constant-mesh type		M8S2 x 5 High-Low selection type; 10-forward and 2-reverse speeds, 1st and reverse by constant-mesh type
Control system		Floor change, remote control type			Floor change, remote control type with power shift
Propeller shaft		P4	P8		Universal joint with center bearing
Front axle		F4T	F6T Reverse Elliot, "I" beam		
Rear axle		R4T	R6T		All-floating type
Reduction		D4H	D8H		Single reduction, hypoid gear
Tire and wheel		8.25-20-12PR	9.00-20-12PR	11.00R22.5-14PR	
Tire size		7.00T x 20-152		7.50 x 22.5-162	
Wheel size					
Front suspension		Semi-elliptic multi-leaf springs with shock absorber			
Rear suspension		Semi-elliptic multi-leaf springs (with auxiliary springs)			
Brakes		Combined air end fluid pressure, dual circuit piping			
Main brake		Propeller shaft brake internal expansion type			
Parking brake		Exhaust brake			
Auxiliary brake					
Steering		Ball nut type integral power steering with booster, Telescopic tilt steering column			
Frame		Straight frame, front kickdown			
Cab		All-steel tilt cab			
Chassis electrical		12-volt, negative-ground type			
Heater		Combined inside and outside air, hot water system			

3. POWER TRAIN TABLE

Item \ Model	FK415	FK455	FM555	FM555 (10-speed transmission)
Engine	6D14	6D14T		
Clutch	C5W33	C6W35		
Transmission	M5S5 7.216/1.000	M6S5 7.216/1.000		M8S2 x 5 (with power shift) 10.060/1.000
Propeller shaft	P4		P8	
Rear axle	R4T		R6T	
Reduction and differential	D4H 4.875 (D4H 5.428)	D4H 4.857 (D4H 5.428)	D8H 5.571	D8H 5.142

4. EQUIPMENT MODEL NOTATION

Equipment name	Model notation	
Engine		<p>With turbocharger</p> <p>Version number</p> <p>Diesel engine</p> <p>No. of cylinders (6: Six cylinders)</p>
Clutch		<p>Disc O.D. (in cm)</p> <p>Facing material (W: Woven)</p> <p>Typical tonnage of model in which the clutch is installed</p> <p>Stands for clutch</p>
Transmission		<p>No. of forward speeds (2 x 5 for one with splitter)</p> <p>Meshing (S: Synchronesh)</p> <p>Typical tonnage of model in which the transmission is installed</p> <p>Stands for transmission</p>
Propeller shaft		<p>Typical tonnage of model in which the transmission is installed</p> <p>Stands for propeller shaft</p>
Front axle		<p>Identification of type of vehicle (T: Truck)</p> <p>Typical tonnage of model in which it is installed</p> <p>Stands for front axle</p>
Rear axle		<p>Identification of type of vehicle (T: Truck)</p> <p>Typical tonnage of model in which it is installed</p> <p>Stands for rear axle</p>
Reduction and differential		<p>Tooth shape (H: Hypoid gear)</p> <p>Typical tonnage of model in which it is installed</p> <p>Stands for reduction and differential</p>

5. PERFORMANCE CURVES

5.1 OPERATION PERFORMANCE CURVES

(1) FK415

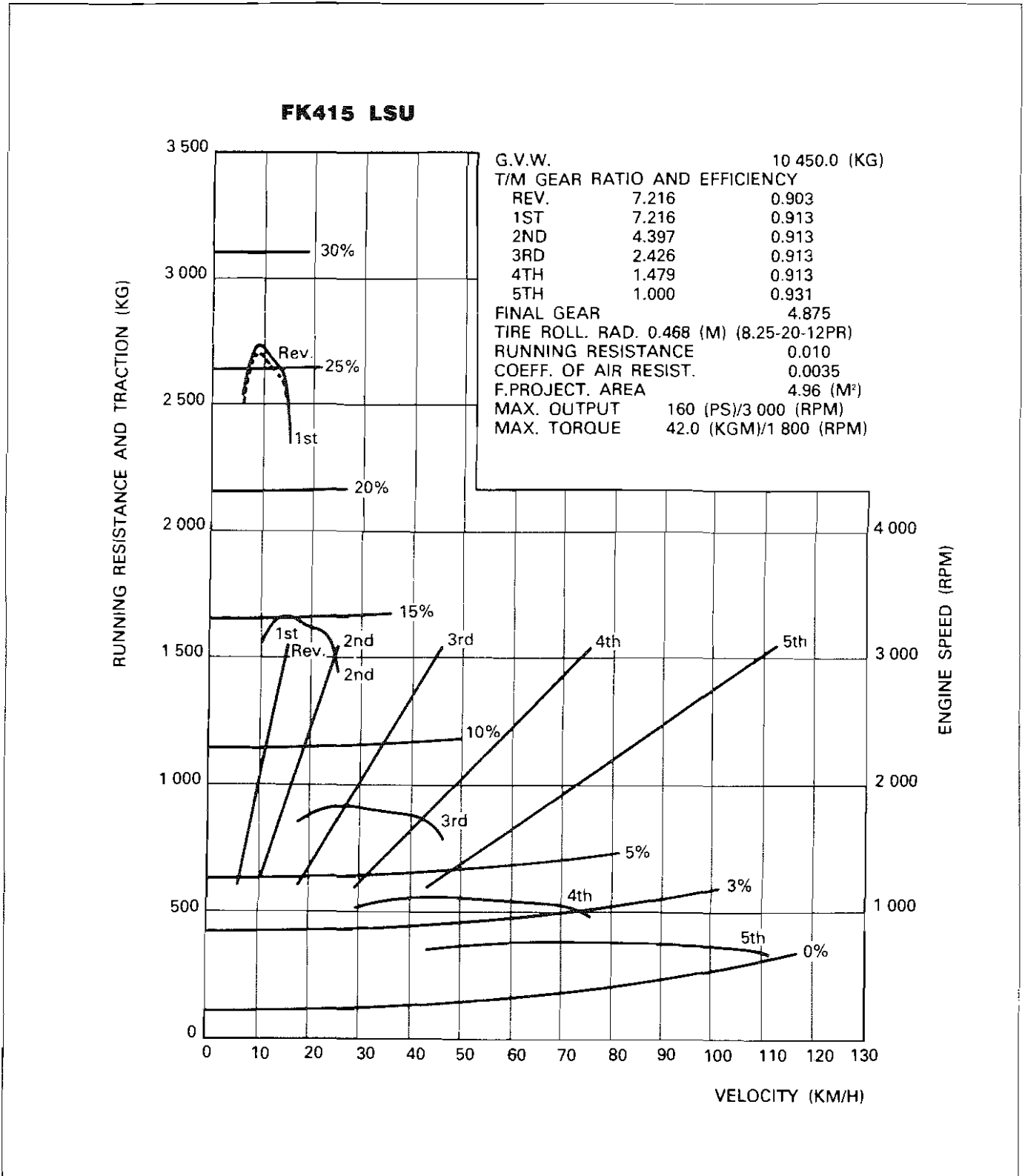

(2) FK455

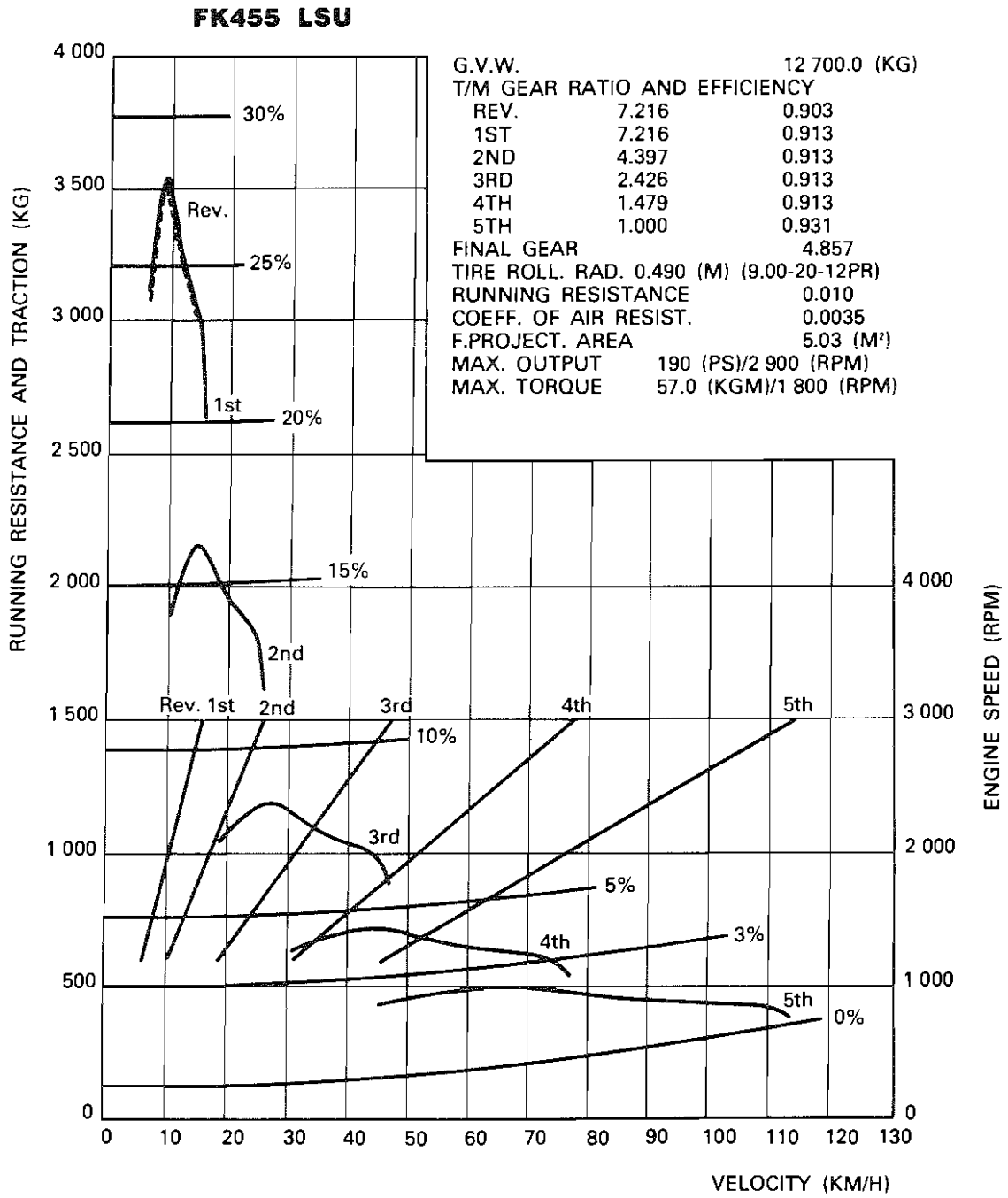

(3) FM555

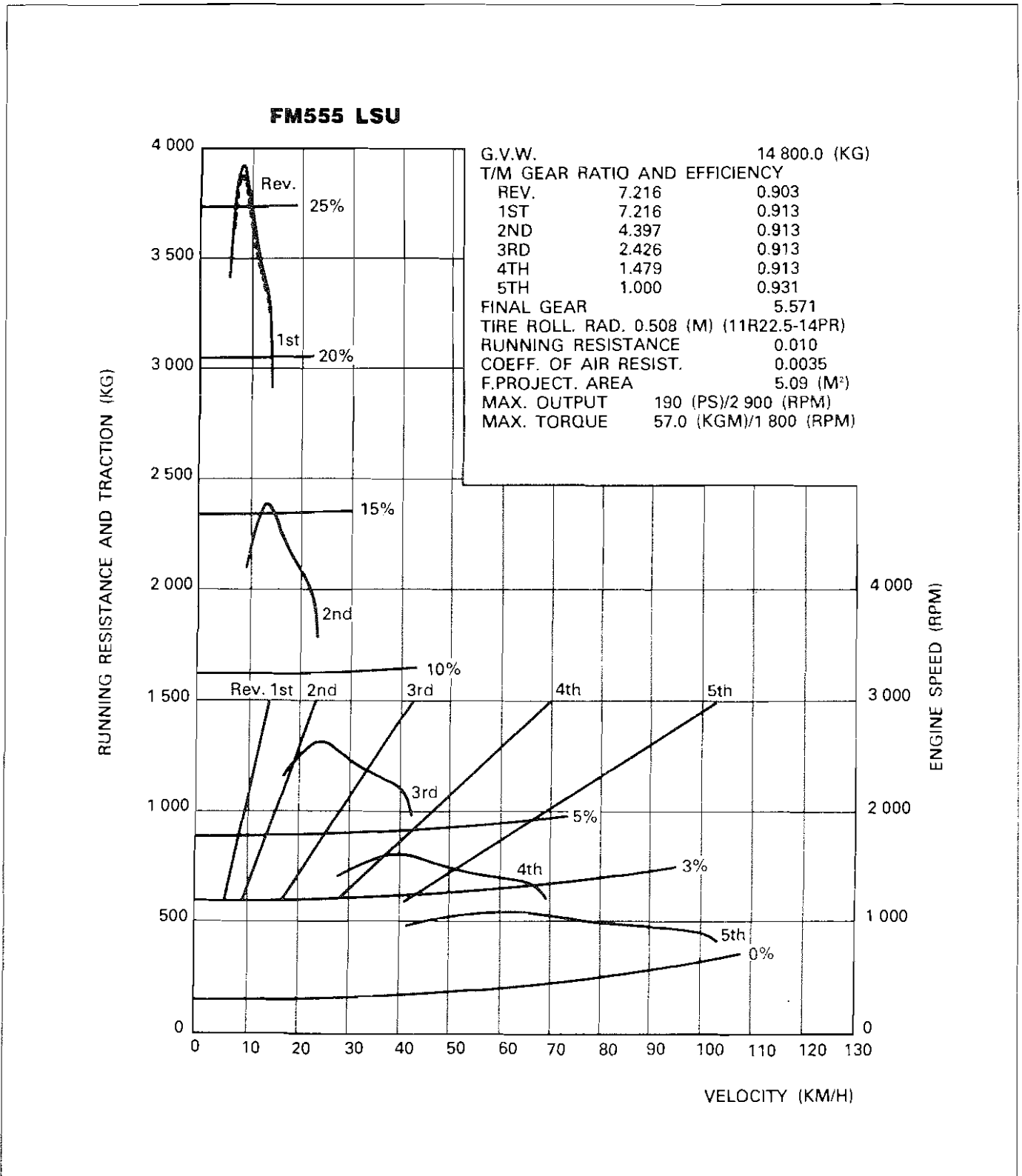

(4) FM555 (Vehicles with M8S2x5 transmission)

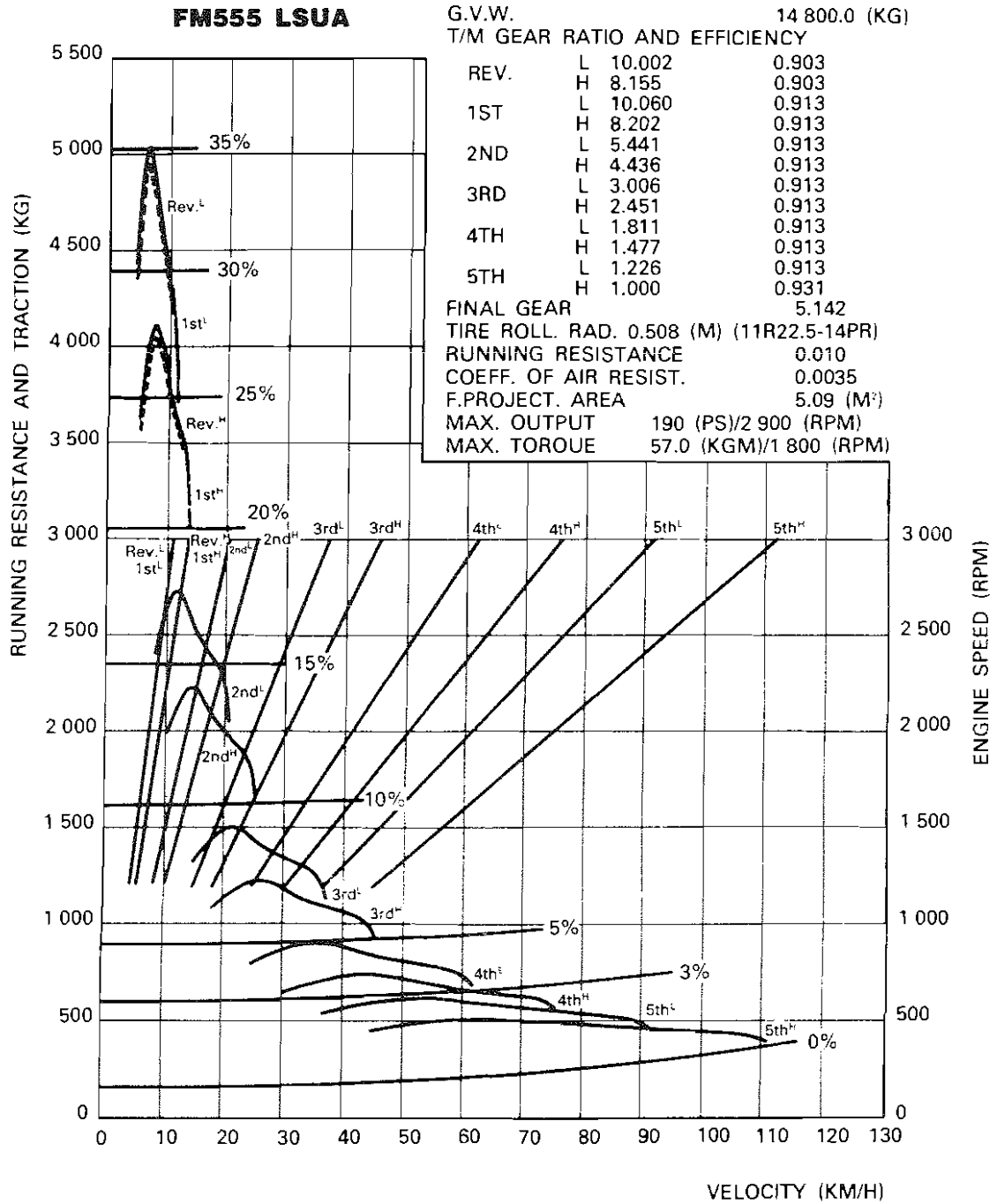

GENERAL – PERFORMANCE CURVES

5.2 ENGINE PERFORMANCE CURVES

(1) 6D14

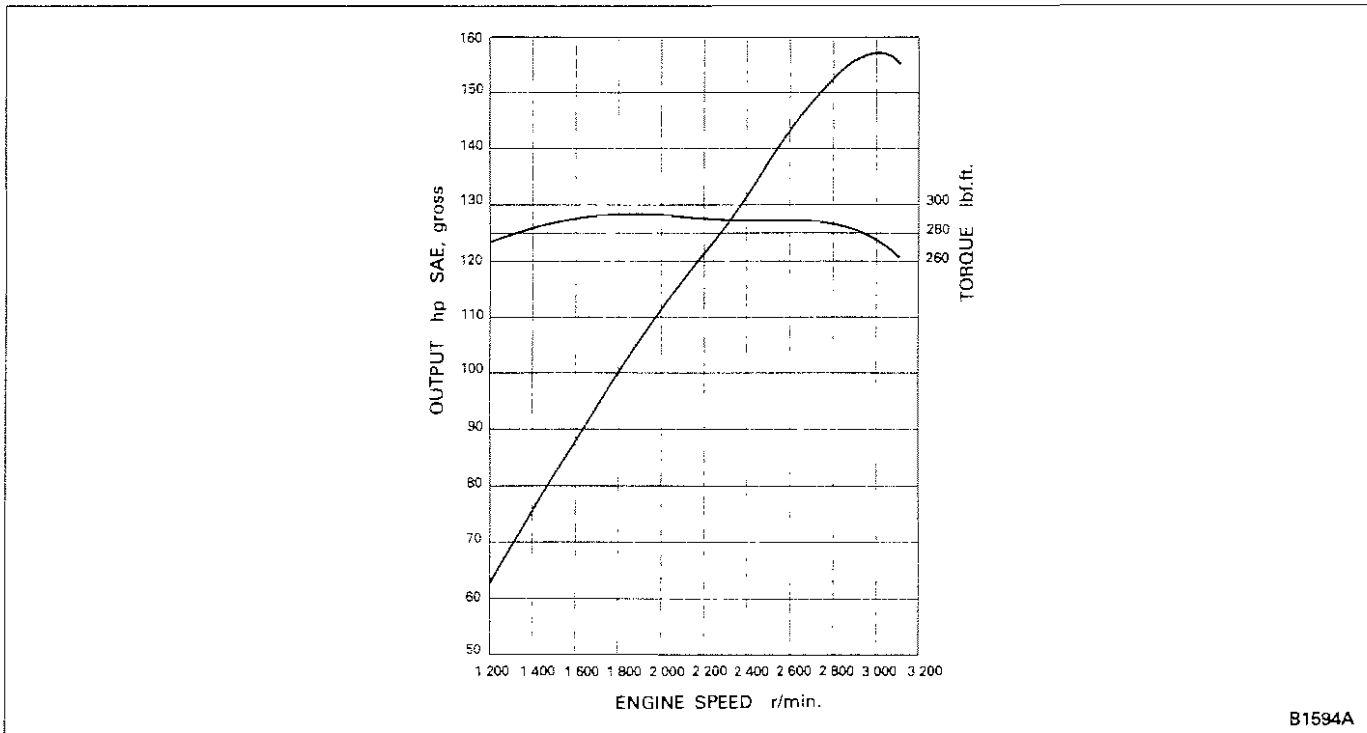

(2) 6D14T (with turbocharger)

