

mitsubishi

MT160

MT160D

MT180

MT180D

INSTRUCTION BOOK





mitsubishi

MT160 MT180
MT160D MT180D

INSTRUCTION BOOK

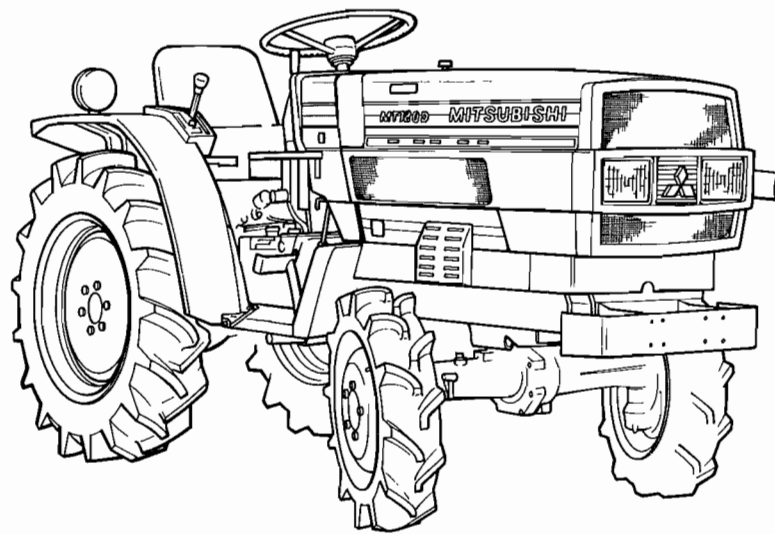

 **MITSUBISHI AGRICULTURAL MACHINERY CO., LTD.**

6-3, KANDA KAJICHO 3-CHOME, CHIYODA-KU,
TOKYO JAPAN

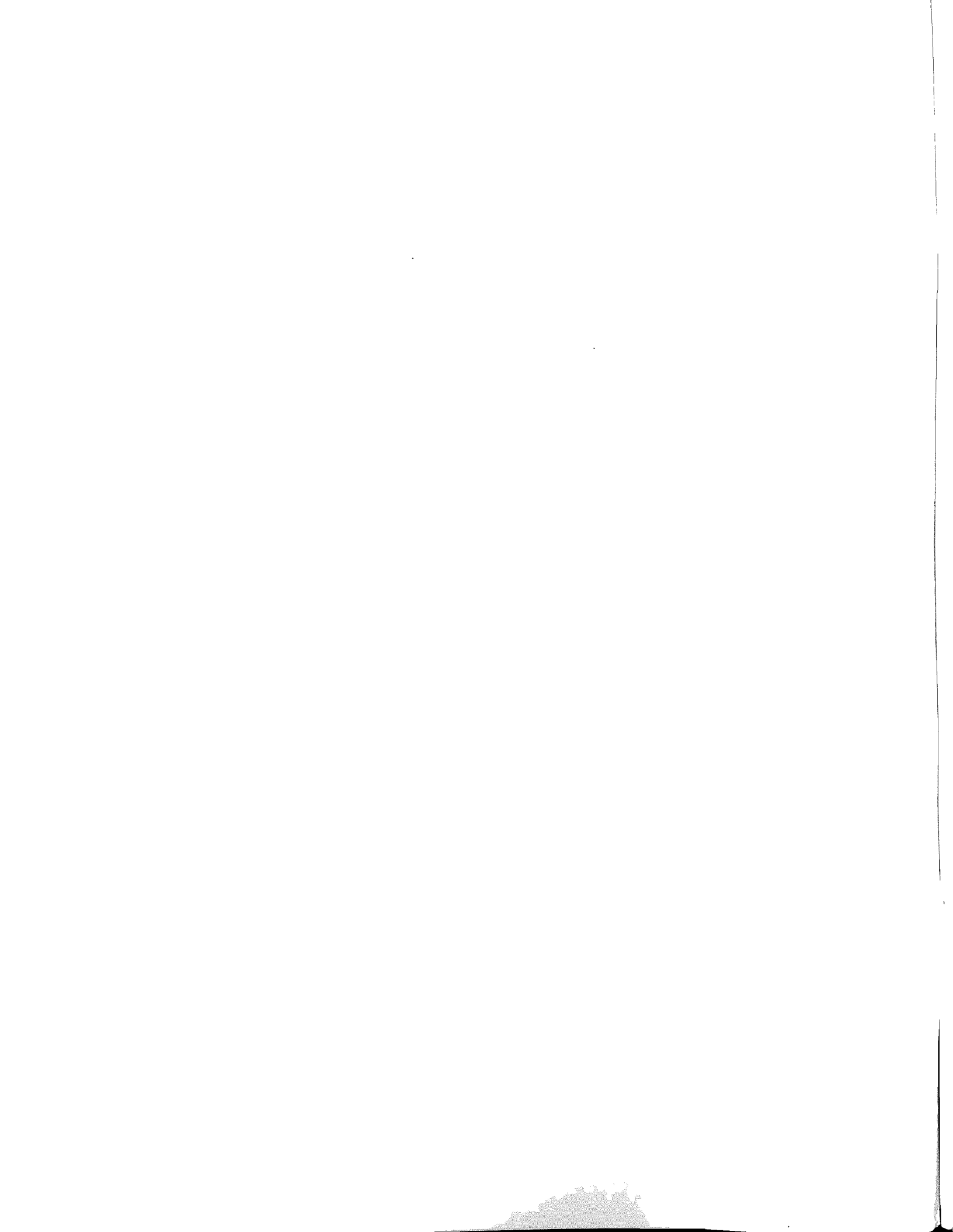

INTRODUCTION

This instruction manual contains information on the operation, lubrication and maintenance of your tractor. The information contained is comprehensive and essential, and is designed to assist you, even if unexperienced, in utilizing your tractor.

How well your tractor continues to give satisfactory performance depends greatly upon the manner in which it is operated. It is, therefore, requested that this manual be read carefully and kept ready for use so that the operation and maintenance services will properly be carried out in order to keep the tractor in top mechanical condition at all times.

Should any information as to your tractor be required, consult your local dealer or distributor stating the machine and engine serial numbers of the tractor concerned.

We are sure you will be happy with your tractor.

NOTE:

Expressions such as LEFT, RIGHT, FRONT or REAR used in this manual should be understood in accordance with following rules:

FRONT means the front grill end while REAR means the lifting arm end of the tractor.

LEFT or RIGHT means the left or right hand side of the tractor looking forward from operator's seat.

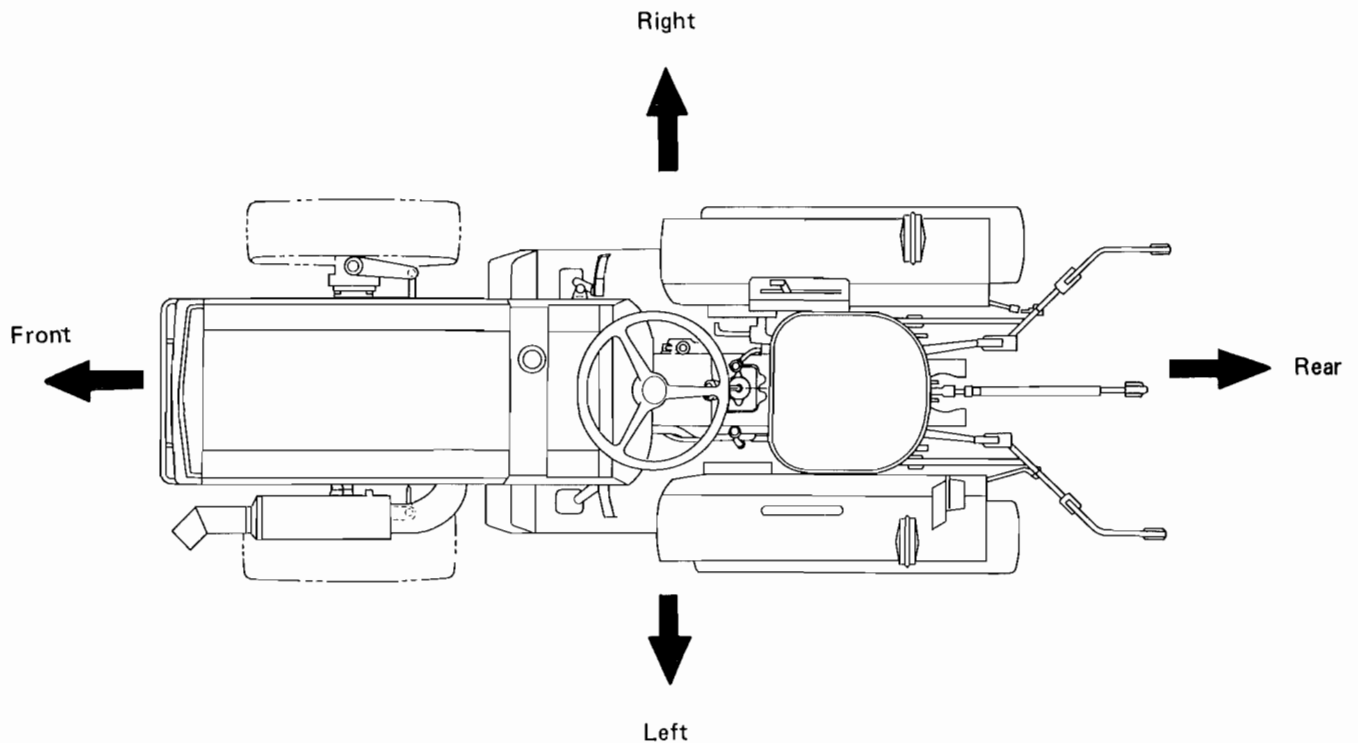

SERIAL NUMBERS

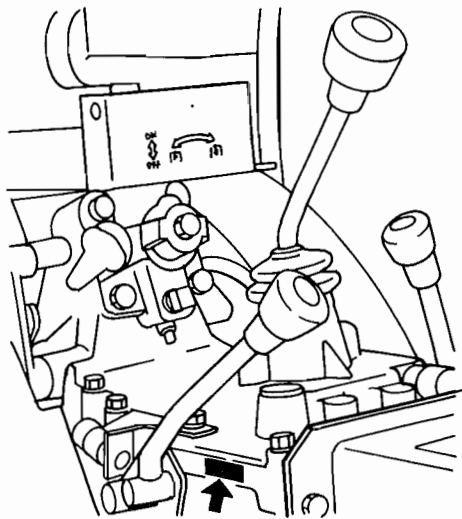

Tractor serial number

It is located at the right side of the transmission case specifically upper side (under HST filter).

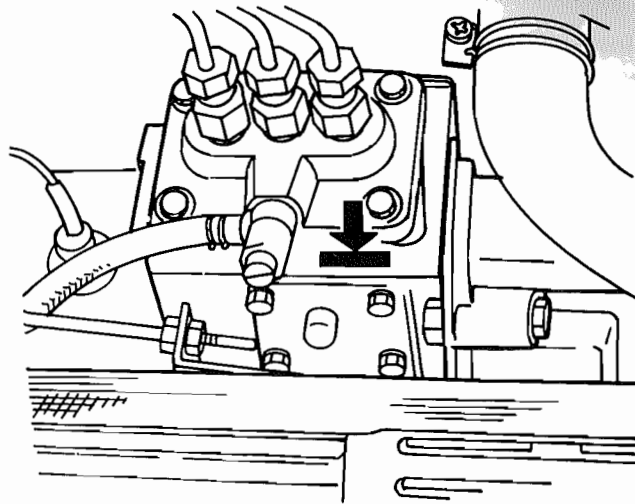

Engine serial number

It is located at the right hand side of the cylinder block, specifically injection pump side.

NOTES, CAUTIONS and WARNINGS

NOTES, CAUTIONS and WARNINGS are used in this manual to emphasize important and critical instructions. They are used for the following conditions:

NOTEAn operating procedure, condition, etc., which is essential to highlight.

CAUTIONOperating procedures, practices, etc., which if not strictly observed, will result in damage to or destruction of machine.

WARNINGOperating procedures, practices, etc., which if not correctly followed, will result in personal injury or loss of life.

TREATMENT OF A NEW TRACTOR

All components of your tractor are subject to stringent checking during assembly in the factory. However, a new tractor should be carefully checked over by the operator himself. For the first 25 ~ 50 hours operation, heavy duty work should be avoided. If heavy duty work is unavoidable, drive in a gear one stage lower than you would normally use, and run the engine at lower rpm.

“IMPORTANT” 50-HOUR SERVICE

When the tractor is brand new, after the first 50 hours running, the following service, maintenance and checking should be carried out by this instruction book.

1. Replace the engine oil filter and engine oil.

2. Replace the transmission oil.
3. Retighten all bolts and nuts, paying special attention to those for steering linkage and wheel.
4. Check and adjust the fan belt tension.
5. Check the wheels to see if their condition is good and tire pressure is correct.
6. Retighten the cylinder head bolts and adjust valve clearances.
7. Front axle diff. case and gear case oil replacement of 4-wheel drive tractor.
8. Cooling water replacement.
9. Air cleaner element cleaning.
10. Clean the fuel filter.
11. Check the front hub for end-play.
12. Check the battery electrolyte.
13. Clean the hydraulic oil filter.

This 50-hour Service is an essential procedure for keeping the tractor in top condition, so it must be done properly.