

THIS MANUAL IS AN ONLINE BACKUP TO YOUR
ORIGINAL HARDCOPY VERSION.

RX7CITY.COM ASSUMES NO RESPONSIBILITY IN HOW YOU USE
THIS MANUAL. THIS MANUAL IS FOR EXPERIENCED MECHANICS
AND IS TO BE USED AT YOUR OWN RISK!



ENGINE

INDEX	C - 2
OUTLINE	C - 3
SPECIFICATIONS	C - 3
TROUBLESHOOTING GUIDE	C - 3
ENGINE TUNE-UP PROCEDURE	C - 5
PREPARATION	C - 5
ENGINE OIL	C - 5
ENGINE COOLANT	C - 5
DRIVE BELT	C - 5
COMPRESSION	C - 9
PREPARATION	C - 9
ON-VEHICLE MAINTENANCE	C - 11
REAR OIL SEAL	C - 11
PREPARATION	C - 11
REMOVAL	C - 14
PREPARATION	C - 14
PROCEDURE	C - 14
ENGINE STAND MOUNTING	C - 21
PREPARATION	C - 21
PROCEDURE	C - 21
DISASSEMBLY	C - 23
PREPARATION	C - 23
AUXILIARY PARTS (I)	C - 24
TURBOCHARGER	C - 25
AUXILIARY PARTS (II)	C - 30
HOUSING (EXTERNAL PARTS I)	C - 36
HOUSING (EXTERNAL PARTS II)	C - 39
HOUSING (INTERNAL PARTS)	C - 41
HOUSING (ROTOR)	C - 43
CLEANING	C - 49
PREPARATION	C - 49
INSPECTION / REPAIR	C - 51
PREPARATION	C - 51
ASSEMBLY	C - 60
PREPARATION	C - 60
HOUSING (ROTOR)	C - 61
HOUSING (INTERNAL PARTS)	C - 62
HOUSING (EXTERNAL PARTS II)	C - 73
HOUSING (EXTERNAL PARTS I)	C - 77
AUXILIARY PARTS (II)	C - 86
TURBOCHARGER	C - 92
AUXILIARY PARTS (I)	C - 97
ENGINE STAND DISMOUNTING	C -100
PROCEDURE	C -100
INSTALLATION	C -101
PREPARATION	C -101
PROCEDURE	C -102

INDEX

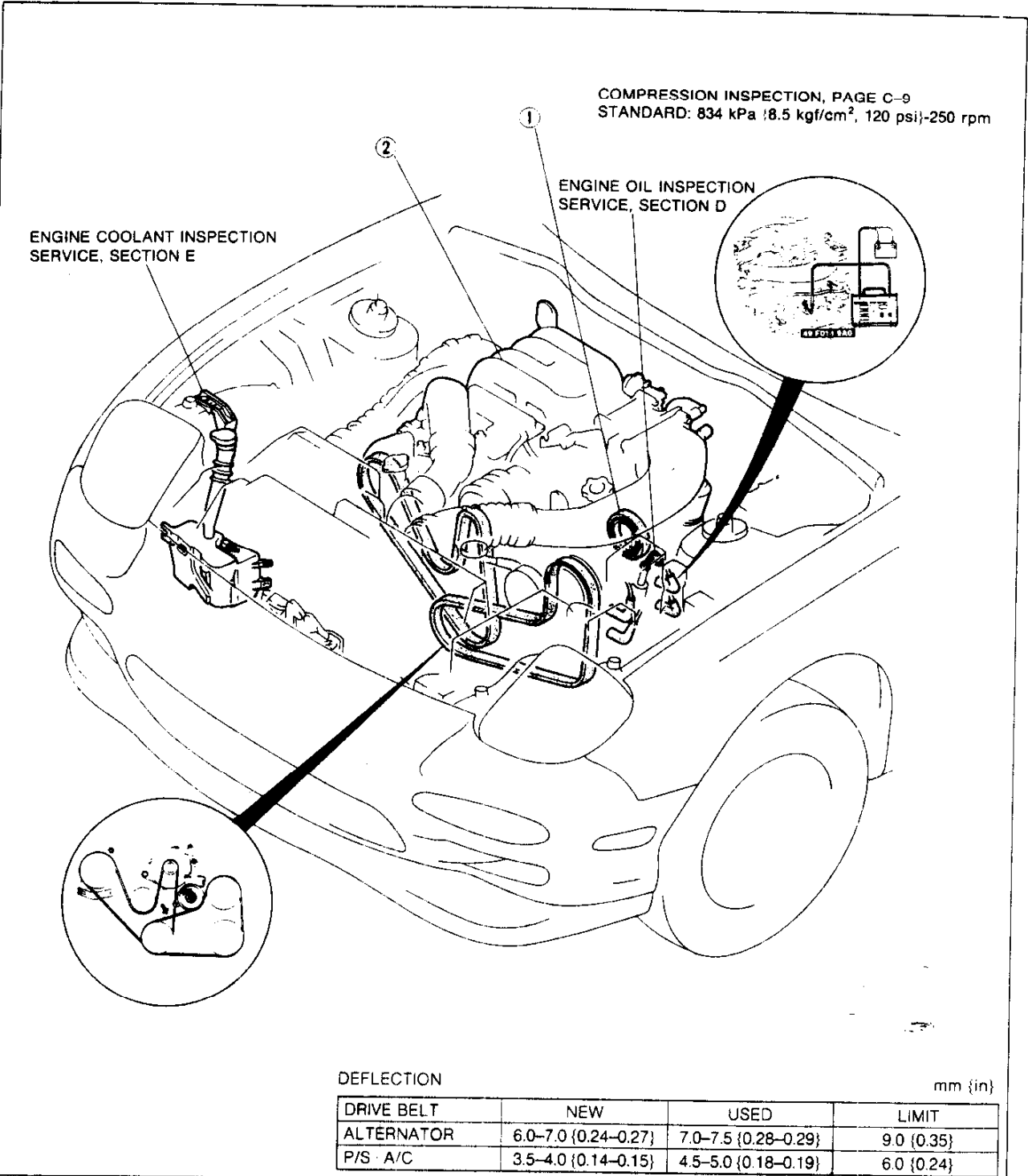

37U0CX-001

1. Rear oil seal Replacement page C- 11

2. Engine
 Removal page C- 14
 Disassembly page C- 23
 Cleaning page C- 49
 Inspection / Repair page C- 51
 Assembly page C- 60
 Installation page C-101

OUTLINE

SPECIFICATIONS

Item		Engine	13B Turbo	
Engine type			Rotary	
Displacement		cm ³ {cu in}	654 × 2 {40.0 × 2}	
Number of cylinders and arrangement			2 rotors, longitudinal	
Combustion chamber type			Bathtub	
Compression ratio			9.0 : 1	
Air induction			4-port induction	
Port timing	Intake	Open	Primary	45° BTDC
			Secondary	32° BTDC
		Close	Primary	50° ABDC
			Secondary	50° ABDC
	Exhaust	Open		75° BBDC
		Close		48° ATDC
Fuel supply system			EGI	
Ignition timing*		Trailing	20°ATDC (-20°BTDC)	
		Leading	5°ATDC (-5°BTDC)	
Idle speed*		rpm	700 - 750	

* TEN terminal of diagnosis connector is grounded.

37UOCX-03

TRUBLESHOOTING GUIDE

Problem	Possible cause	Action	Page
Difficult starting	Insufficient compression		
	Deformation or abnormal wear of side housing	Replace	C-51
	Deformation or abnormal wear of rotor housing	Replace	C-54
	Wear of rotor grooves	Replace	C-57, 58
	Deformation of or loose rotor seals	Replace	C-57, 58
	Worn or weak rotor seal springs	Replace	-
	Malfunction of metering oil pump		Section D
	Malfunction of electrical system		Section F
	Malfunction of electrical system		Section G
Poor idling	Insufficient compression		
	Deformation or abnormal wear of side housing	Replace	C-51
	Deformation or abnormal wear of rotor housing	Replace	C-54
	Wear of rotor grooves	Replace	C-57, 58
	Deformation or loose rotor seals	Replace	C-57, 58
	Worn or weak rotor seal springs	Replace	-
	Malfunction of fuel system		Section F
	Malfunction of ignition system		Section G

37UOCX-034

C

TROUBLESHOOTING GUIDE

Problem	Possible cause	Action	Page
Insufficient power	Insufficient compression Deformation or abnormal wear of side housing Deformation or abnormal wear of rotor housing Wear of rotor grooves Deformation or loose rotor seals Worn or weak rotor seal springs	Replace Replace Replace Replace	C-51 C-54 C-57, 58 C-57, 58
	Malfunction of fuel system		Section F
	Malfunction of ignition system		Section G
Abnormal combustion	Malfunction in combustion chamber Carbon accumulation	Remove and clean	C-49
	Malfunction of fuel system		Section F
	Malfunction of ignition system		Section G
Excessive oil consumption	Leakage into combustion chamber Deformation or abnormal wear of side housing Malfunction of rotor (blow holes) Scratched or burred rotor land Malfunction of oil seal (incorrect angle)	Replace Replace Replace Replace	C-51 C-54 C-54 C-56
	Leakage into coolant passages Deformed rotor housing Malfunction of sealing rubber	Replace Replace	C-54 -
	Leakage to outside of engine		Section D
	Malfunction of lubrication system		Section D
Engine noise	Rotor seal noise Malfunction of rotor seals Malfunction of housing Malfunction of seal spring Malfunction of metering oil pump	Replace Replace Replace	C-56, 57 C-51, 54 C-56, 57 Section D
	Knocking noise Accumulation of carbon	Remove and clean	C-49
	Hitting noise Malfunction of main bearing or rotor bearing Excessive end play Foreign matter in internal gear or stationary gear or malfunction of gear	Replace Adjust Replace	C-53, 56 C-73 C-53
	Other Malfunction of water pump bearing Loose drive belt Malfunction of alternator bearing Exhaust gas leakage Malfunction of fuel system	Adjust	Section E C-5 Section G Section F Section F

37UOCX-005

ENGINE TUNE-UP PROCEDURE

PREPARATION
SST

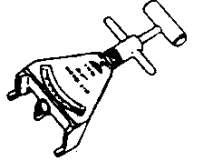
<p>49 9200 020 Tension gauge, V-ribbed belt</p>		<p>For inspection of drive belt tension</p>
---	---	---

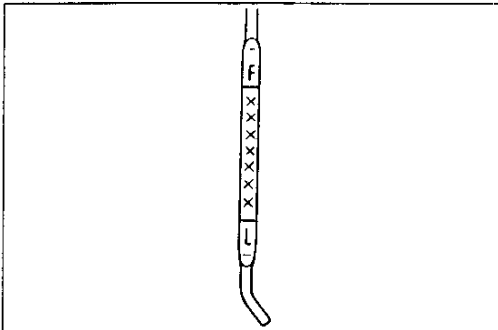

37UOCX-006

16E0B1-006
ENGINE OIL
Inspection

1. Be sure the vehicle is on level ground.
2. Warm up the engine to normal operating temperature and stop it.
3. Wait for five minutes.
4. Remove the oil level dipstick and check the oil level and condition.
5. Add or replace oil if necessary.

Note

- The distance between the L and F marks on the dipstick represents 1.7L {1.8 US qt, 1.5 Imp qt}.

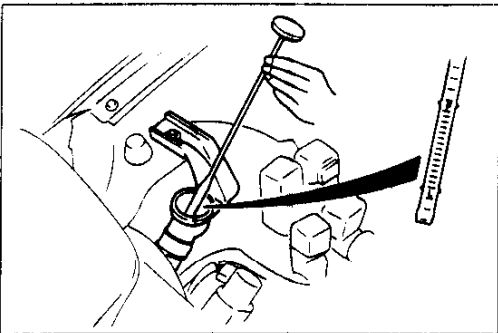

16E0B1-008

ENGINE COOLANT
Inspection
Coolant level (Engine cold)

Warning

- Never remove the radiator cap while the engine is hot.
- Wrap a thick cloth around the cap when removing it.

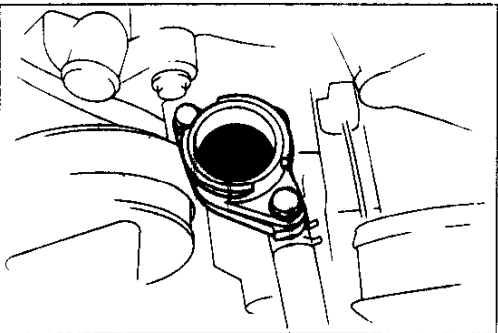

16E0B1-009

1. Verify that the coolant level is near the filler port neck.
2. Remove the coolant level dipstick from the coolant reservoir and verify that the coolant level is between the F and L marks. Add coolant if necessary.

Coolant quality

1. Verify that there is no buildup of rust or scale around the radiator cap and radiator filler neck.
2. Verify that the coolant is free of oil.
3. Replace the coolant if necessary.

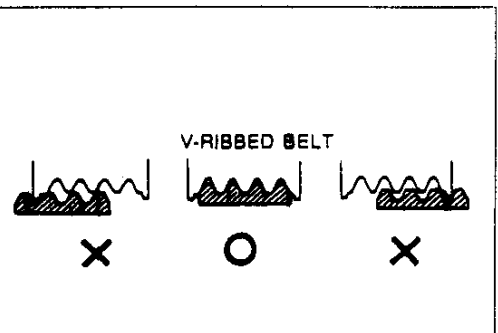

16E0B1-010

DRIVE BELT
Inspection

1. Check the drive belts for wear, cracks, and fraying. Replace if necessary.
2. Verify that the drive belts are correctly mounted on the pulleys.

C

ENGINE TUNE-UP PROCEDURE

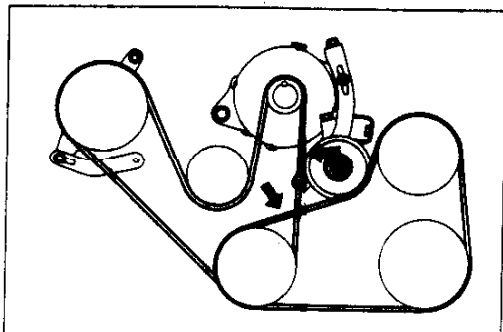

37U0CX-007

3. Check the drive belt deflection by applying moderate pressure **98 N {10 kgf, 22 lbf}** midway between the pulleys.

Note

- Measure the belt deflection between the specified pulleys.
- A belt is considered "New" if it has been used on a running engine for less than 5 minutes. Set the deflection specified below accordingly.
- Check the belt deflection when the engine is cold, or at least 30 minutes after the engine has stopped.

Deflection

mm { in }

Drive belt	New	Used	Limit
Alternator	6.0-7.0 {0.24-0.27 }	7.0-7.5 {0.28- 0.29 }	9.0 {0.35}
P/S-A/C	3.5-4.0 {0.14-0.15}	4.5-5.0 {0.18-0.19}	6.0 {0.24}

4. If the deflection is not within specification, adjust it.

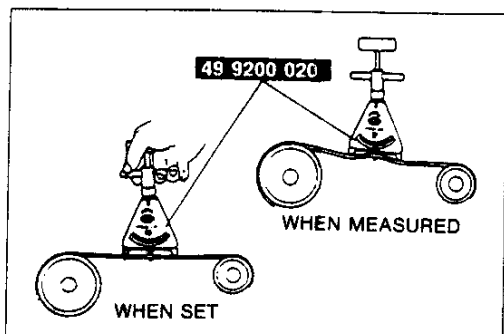

37U0CX-008

Drive belt tension check

Note

- Belt tension can be checked in place of belt deflection.
- Belt tension can be measured between any two pulleys.

1. Using the **SST**, check the belt tension.

Tension

N {kgf·lbf}

Drive belt	New	Used	Limit
Alternator	690-780 {70-80, 160-170}	590-680 {60-70, 140-150}	320 {33, 73}
P/S-A/C	740-880 {75-90, 170-190}	540-630 {55-65, 130-140}	320 {33, 73}

2. If the tension is not within specification, adjust it.

Adjustment

Caution

- A belt is considered "New" if it has been used on a running engine for less than 5 minutes.

Alternator

1. Loosen bolt A and nut B.
2. Adjust the belt deflection by turning adjusting bolt C.

Deflection

New : 6.0-7.0 mm {0.24-0.27 in}
Used : 7.0-7.5 mm {0.28-0.29 in}
Limit : 9.0 mm {0.35 in}

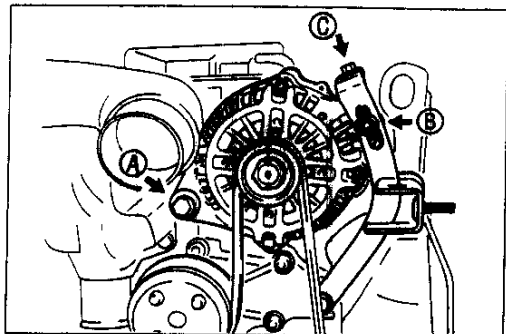

37U0CX-009

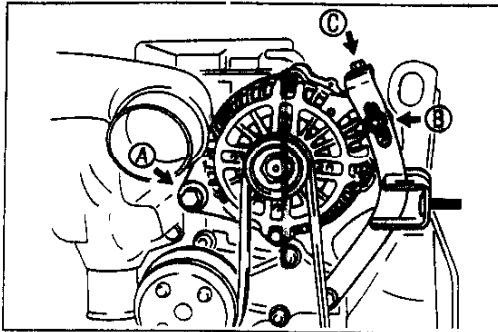

37U0CX-010

3. Tighten bolt A, and nut B.

Tightening torque:

Bolt A 38–51 N·m {3.8–5.3 kgf·m, 28–38 ft·lbf}
Nut B 19–25 N·m {1.9–2.6 kgf·m, 14–18 ft·lbf}

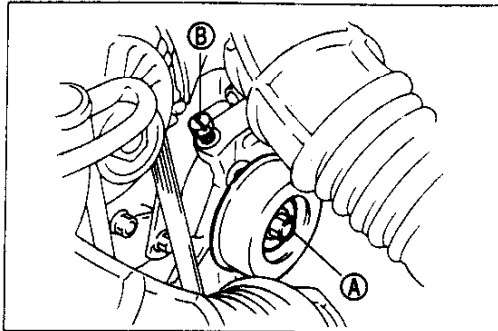

37U0CX-011

P/S, A/C

1. Loosen nut A.
2. Adjust the belt deflection by turning adjusting bolt B.

Deflection

New : 3.5–4.0 mm {0.14–0.15 in}
Used: 4.5–5.0 mm {0.18–0.19 in}
Limit: 6.0 mm {0.24 in}

3. Tighten nut A.

Tightening torque:

37–53 N·m {3.7–5.5 kgf·m, 27–39 ft·lbf}

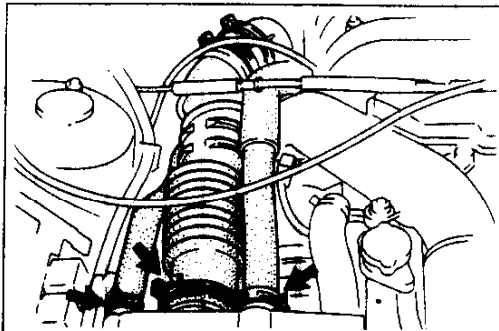

37U0CX-012

**Replacement
P/S, A/C**

1. Disconnect the air hoses shown in the figure.

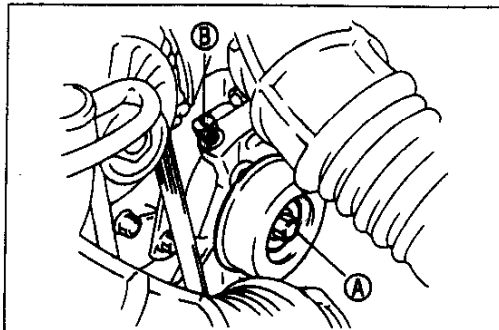

37U0CX-013

2. Loosen idler pulley locknut A.
3. Loosen adjusting bolt B.
4. Remove the belt.

C

ENGINE TUNE-UP PROCEDURE

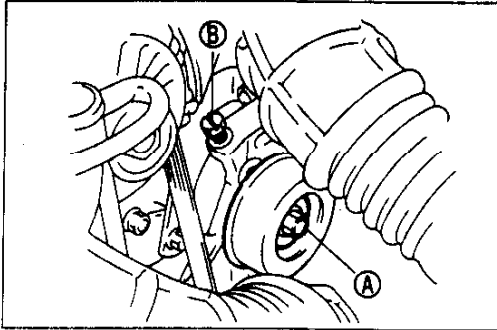

37U0CX-014

5. Install the new belt on the pulleys.
6. Adjust the belt deflection by turning adjusting bolt B.

Deflection

3.5–4.0mm {0.14–0.15 in}

7. Tighten pully locknut A.

Tightening torque:

37–53 N·m {3.7–5.5 kgf·m, 27–39 ft·lbf}

8. Connect the air hoses.

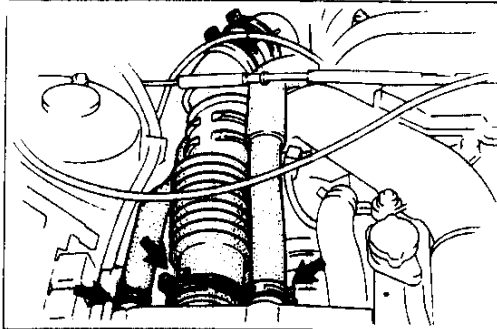

37U0CX-015

Alternator

1. Disconnect the air hoses shown in the figure.

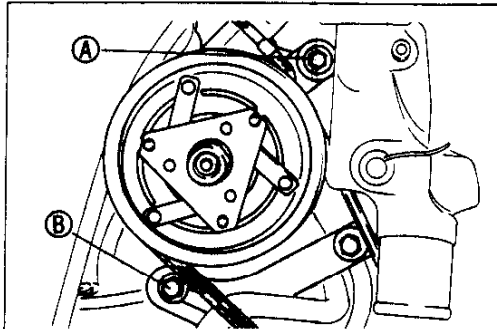

37U0CX-016

2. Loosen air pump mount bolts A and B.

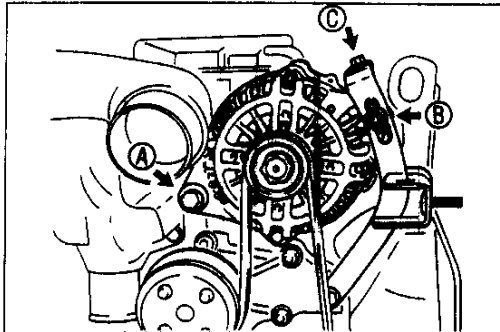

37U0CX-017

3. Loosen alternator mount bolt A and locknut B.
4. Loosen adjusting bolt C.
5. Remove the drive belt.

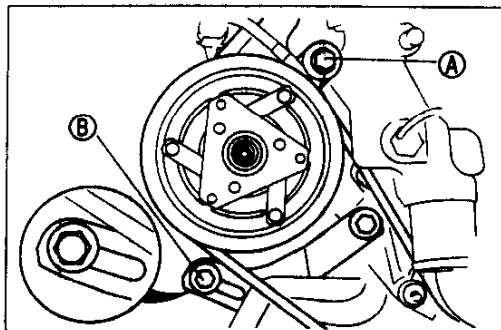

37U0CX-018

6. Install the new drive belt on the pulleys.
7. Install the air pump while applying the pressure the drive belt.

Tightening torque:

19–25 N·m {1.9–2.6 kgf·m, 14–18 ft·lbf}

ENGINE TUNE-UP PROCEDURE , COMPRESSION

C

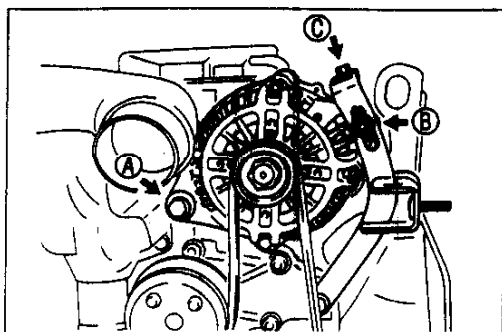

37U0CX-019

8. Adjust the belt deflection by turning adjusting bolt C.

Deflection

6.0–7.0 mm {0.24–0.27 in}

9. Tighten alternator mount bolt A and locknut B.

Tightening torque:

Bolt A 37–51 N·m {3.8–5.3 kgf·m, 28–38 ft·lbf}

Nut B 19–25 N·m {1.9–2.6 kgf·m, 14–18 ft·lbf}

10. Connect the air hoses.

COMPRESSION

If the engine exhibits low power, poor fuel economy, or poor idle, check the following:

1. Ignition system (Refer to Section G.)
2. Compression
3. Fuel system (Refer to Section F.)

37U0CX-020

PREPARATION

SST

<p>49 F018 9A0</p> <p>Tester, compression</p>		<p>For Inspection of compression</p>
---	--	--

37U0CX-013

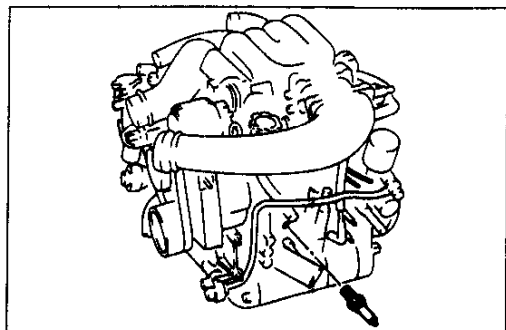

37U0CX-022

1. Check that the battery is fully charged. Recharge it if necessary.
2. Warm up the engine to the normal operating temperature, then stop it.
3. Allow about 10 minutes for the exhaust manifold to cool.
4. Remove the front and rear trailing-side spark plugs.
5. Disconnect the circuit-opening relay and the igniter connector.