



# Онлайн-аукционы

Аукционы которым можно доверять.

## СТОПРОЦЕНТНАЯ ГАРАНТИЯ И ЭКСПЕРТЫ, КОТОРЫМ МОЖНО ДОВЕРЯТЬ



Покупайте уверенно на аукционах с IronPlanet. Печать **IronClad** обеспечивает гарантию, вы можете быть уверены, что получаете оборудование согласно акта технического освидетельствования.



### Что такое IronClad гарантировано

Печать IronClad обеспечивает гарантию и означает, что один из наших инспекторов лично провел визуальное техническое освидетельствование всех ключевых компонентов, сделал необходимые фотографии, провел технические замеры для определения степени износа и, при необходимости, взял масла / жидкости для лабораторных анализов.

Акты технического освидетельствования на оборудование предоставляются для ознакомления бесплатно перед началом торгов. Мы гарантируем Вам, что Акты технического освидетельствования составлены честно и дают истинную картину о состоянии оборудования.

НЕ УПУСТИТЕ СВОЙ ШАНС ПОКУПКИ КАЧЕСТВЕННОГО ОБОРУДОВАНИЯ



**автобай**  
АВТОМОБИЛЬНАЯ КОМПАНИЯ

[marketing@autoby.by](mailto:marketing@autoby.by)

**ПОКУПКА НА АУКЦИОНЕ - ТАМОЖЕННОЕ СОПРОВОЖДЕНИЕ - ДОСТАВКА "ДО ДВЕРИ"**

Page Title	Page Number
Engine And Equipment	010-0005
Alternator And Bracket - Up to Serial or Engine Number - K110016	010-0010
Alternator And Bracket - From Serial or Engine Number - K110017	010-0015
Alternator - Valeo - Up to Serial or Engine Number - K110016	010-0020
Alternator - ISKRA - From Serial or Engine Number - K110017	010-0025
Starter - Magneti Marelli - Up to Serial or Engine Number - K073010	010-0030
Starter - ISKRA - From Serial or Engine Number - K073011	010-0035
Cylinder Block	010-0040
Timing Gear Housing	010-0045
Flywheel Housing - Dynashift	010-0050
Flywheel Housing - With Full Powershift	010-0055
Crankshaft, Pistons And Connecting Rods	010-0060
Valve Mechanism And Camshaft	010-0065
Cylinder Head	010-0070
Cylinder Head Cover	010-0075
Thermostat	010-0080
Lubricating Oil Sump - Up to Serial or Engine Number - J14443	010-0085
Lubricating Oil Sump - From Serial or Engine Number - J14444	010-0090
Lubricating Oil Pump - Up to Serial or Engine Number - J7890	010-0095
Lubricating Oil Pump - From Serial or Engine Number - J7891	010-0100
Lubricating Oil Cooler And Filter	010-0105
Water Pump - M.F 8250	010-0110
Water Pump - M.F 8250 XTRA	010-0115
Fuel Injection Equipment (Diesel) - M.F 8250	010-0120
Fuel Injection Equipment (Diesel) - M.F 8250 XTRA	010-0125
Fuel Injection Equipment (Diesel)	010-0130
Feed Pump - M.F 8250	010-0135
Feed Pump - M.F 8250 XTRA	010-0140
Stop Magnet - Up to Serial or Engine Number - K 12633	010-0145
Stop Magnet - From Serial or Engine Number - K 12634	010-0150
Low Pressure Fuel System	010-0155
Air Induction And Exhaust System - M.F 8250	010-0160
Air Induction And Exhaust System - M.F 8250 XTRA	010-0165
Turbocharger - Pipes - M.F 8250	010-0170
Turbocharger - Pipes - M.F 8250 XTRA	010-0175
Cold Starting Device - M.F 8250	010-0180
Belt Tensioner - Up to Serial or Engine Number - K 18108	010-0185
Belt Tensioner - From Serial or Engine Number - K 18109	010-0190
Engine Repair Kits - Piston- Cylinder Head With Valves	010-0195
Engine Gaskets Sets	010-0200
Heater Engine Block - Up to Serial or Engine Number - L155012	010-0205
Heater Engine Block - From Serial or Engine Number - L155013	010-0210
Heater Engine Block	010-0215
Battery & Cables - Without Battery Cut-Off W/O Positive Connection	010-0220
Battery & Cables - With Battery Cut-Off	010-0225
Battery & Cables - Without Battery Cut-Off With Positive Connection	010-0230
Cooling System - Air Conditioned Installation - M.F 8250 - Up To 07-09-2000	010-0235
Cooling System - Air Conditioned Installation - M.F 8250 - From 08-09-2000	010-0240
Cooling System - Air Conditioned Installation - M.F 8250 XTRA	010-0245
Sanden Compressor	010-0250
Cooling System - Engine	010-0255
Cab Heating System - Engine Part	010-0260
Fuel System - Fuel Tank And Attachments - Without Additional Tank	010-0265
Fuel System - Fuel Tank And Attachments - With Additional Tank	010-0270

Fuel System - Fuel Tank And Attachments - With Additional Tank	010-0275
Fuel System - Fuel Filters And Pipes - M.F 8250 - WITHOUT FUEL FLOWMETER	010-0280
Fuel System - Fuel Filters And Pipes - M.F 8250 XTRA - WITHOUT FUEL FLOWMETER	010-0285
Fuel System - Fuel Filters And Pipes - M.F 8250 - With Flow Fuel	010-0290
Fuel System - Fuel Filters And Pipes - M.F 8250 XTRA - With Flow Fuel	010-0295
Fuel System - Fuel Filters And Pipes - M.F 8250 - WITH FUEL COOLER	010-0300
Fuel System - Fuel Filters And Pipes - M.F 8250 XTRA - WITH FUEL COOLER	010-0305
Fuel System - Fuel Filters And Pipes - M.F 8250 - WITH FLOW METER AND FUEL COOLER	010-0310
Fuel System - Fuel Filters And Pipes - M.F 8250 XTRA - WITH FLOW METER AND FUEL COOLER	010-0315
Sedimenter	010-0320
Fuel System - Fuel Tank And Attachments	010-0325
Fuel System - Fuel Tank And Attachments - With Full Powershift	010-0330
Air Filter - Dry - Dual Element - M.F 8250 - Up To ...	010-0335
Air Filter - Dry - Dual Element - M.F 8250 - From ...	010-0340
Air Filter - Dry - Dual Element - M.F 8250 XTRA	010-0345
Air Filter - Dry - Dual Element - M.F 8250	010-0350
Air Filter - Dry - Dual Element - M.F 8250 XTRA	010-0355
Air Cooler - M.F 8250	010-0360
Air Cooler - M.F 8250 XTRA	010-0365
Vertical Exhaust On The Side - Up to Serial or Engine Number - ...	010-0370
Vertical Exhaust On The Side - From Serial or Engine Number - ...	010-0375
Throttle Controls	010-0380
Throttle Controls - With AUTODRIVE	010-0385
Throttle Controls - Up To No J075003 FULL POWERSHIFT / J084021 DYNAS HIFT	010-0390
Throttle Controls - From No J075004 FULL POWERSHIFT / J084022 DYNASH IFT	010-0395
Throttle Controls - Up To 07-01-2001	010-0400
Throttle Controls - From 08-01-2001	010-0405

MF 8250 TRACTOR - 1637366  
1-ZA06-008-E

1-ZA06-008-E

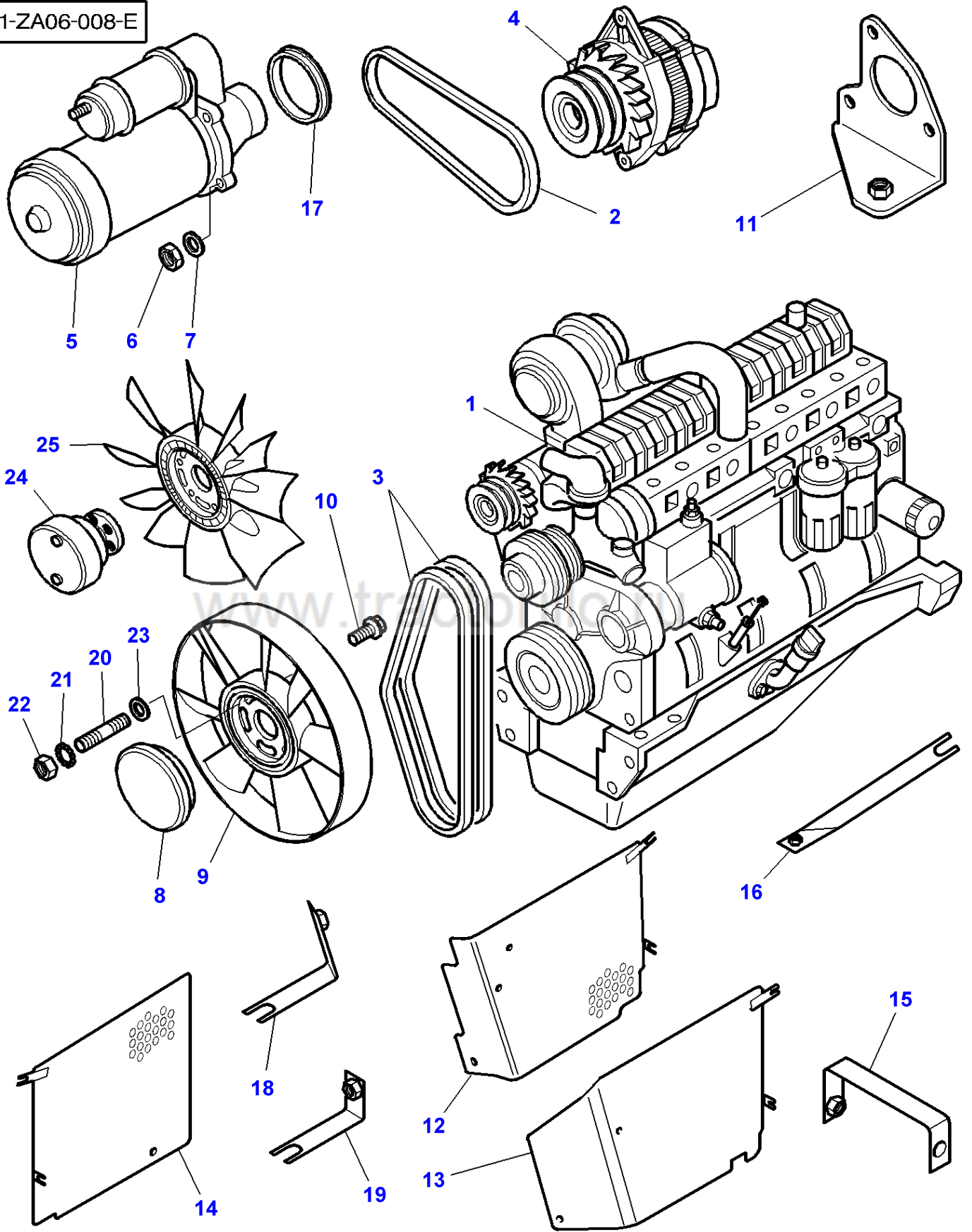



## Engine And Equipment

Item	Part Number	Qty	Description	Comments
1	3782110M91	1	Engine	[A] MF 8250 634 DSBAE Up to Serial or Engine Number J075003
	V832857957	1	Engine	[A] MF 8250 634 DSBAE From Serial or Engine Number J075004 Up to Serial or Engine Number 07-SEP-2000 Replace and repair. Old not interchangeable with new 3784452M91
	V832860333	1	Engine	[A] MF 8250 634 DSBAE From Serial or Engine Number 08-SEP-2000 Replace and repair. Old not interchangeable with new 3784435M91
	3779436M91	1	Engine	[B] MF 8250 634 DSBAE Up to Serial or Engine Number J084021
	V832857744	1	Engine	[B] MF 8250 634 DSBAE From Serial or Engine Number J084022 Up to Serial or Engine Number 07-SEP-2000 Replace and repair. Old not interchangeable with new 3784454M91
	V832860332	1	Engine	[B] MF 8250 634 DSBAE From Serial or Engine Number 08-SEP-2000 Replace and repair. Old not interchangeable with new 3784439M91
	V832860343	1	Engine	[A] MF 8250 XTRA 634 DWBAE
	V832860342	1	Engine	[B] MF 8250 XTRA 634 DWBAE
2	<b>5016260M1</b>	1	Belt	
3	<b>3617180M91</b>	1	Kit, Belt	MF 8250 Length 1470 MM
	<b>3381364M91</b>	1	Kit, Belt	MF 8250 XTRA Up to Serial or Engine Number 31-JUL-2002 Length 1500 MM
	3786922M91	1	Belt,Fan	MF 8250 XTRA From Serial or Engine Number 01-AUG-2002 Length 1510 MM
4	3780634M1	1	Alternator	Up to Serial or Engine Number K110016 120 AMP. See Page - Reference Number 010-0020/1
	3821976M92	1	Alternator	From Serial or Engine Number K110017 120 AMP. See Page - Reference Number 010-0025/1
5	3581576M3	1	Startermotor	[C] Up to Serial or Engine Number K073010 See Page - Reference Number 010-0030/1
	3784889M2	1	Startermotor	[C] From Serial or Engine Number K073011 See Page - Reference Number 010-0035/1
6	339402X1	3	Nut	M10
7	339369X1	3	Lock Washer	
8	3783352M1	1	Clutch	MF 8250
9	3780204M1	1	Fan	MF 8250
10	3009920X1	6	Plough Bolt	M8 X 16
11	3781103M1	1	Support	Up to Serial or Engine Number K110016
	3785725M1	1	Support	From Serial or Engine Number K110017
12	3782011M3	1	Cowl	Right Hand Up to Serial or Engine Number 26-07-1999
	3783248M4	1	Cowl	Right Hand From Serial or Engine Number 27-07-1999 Up to Serial or Engine Number 27-08-2000
13	3785239M1	1	Cowl	From Serial or Engine Number 28-08-2000 Right Hand

## Engine And Equipment

Item	Part Number	Qty	Description	Comments
14	3782010M3	1	Cowl	Left Hand Up to Serial or Engine Number 27-08-2000
14	3785264M1	1	Cowl	From Serial or Engine Number 28-08-2000 Left Hand
15	3782045M1	1	Strap	
16	3783247M1	1	Strap	
17	3778469M1	1	Spacer	[A] From Serial or Engine Number H116020
18	3783245M1	2	Support	Up to Serial or Engine Number K099027
19	3783246M1	1	Strap	From Serial or Engine Number H200022
20	391005X1	6	Stud	MF 8250 XTRA Up to Serial or Engine Number L170033 M10 X 25
20	3011339X1	6	Stud	MF 8250 XTRA From Serial or Engine Number L170034 M10 X 22
21	339376X1	6	Lock Washer	MF 8250 XTRA Up to Serial or Engine Number L170033
22	1441932X1	6	Nut Metric	MF 8250 XTRA M10
23	385362X1	6	Washer	MF 8250 XTRA Up to Serial or Engine Number L170034
24	3788062M1	1	Clutch	MF 8250 XTRA
25	3788063M1	1	Fan	MF 8250 XTRA

FOOTNOTE [A] WITH FULL POWERSHIFT

FOOTNOTE [B] WITH DYNASHIFT

FOOTNOTE [C] THE APPROPRIATE SAFETY DECALS MUST BE ORDERED AND FITTED TO THIS PART

1-ZA10-003-A

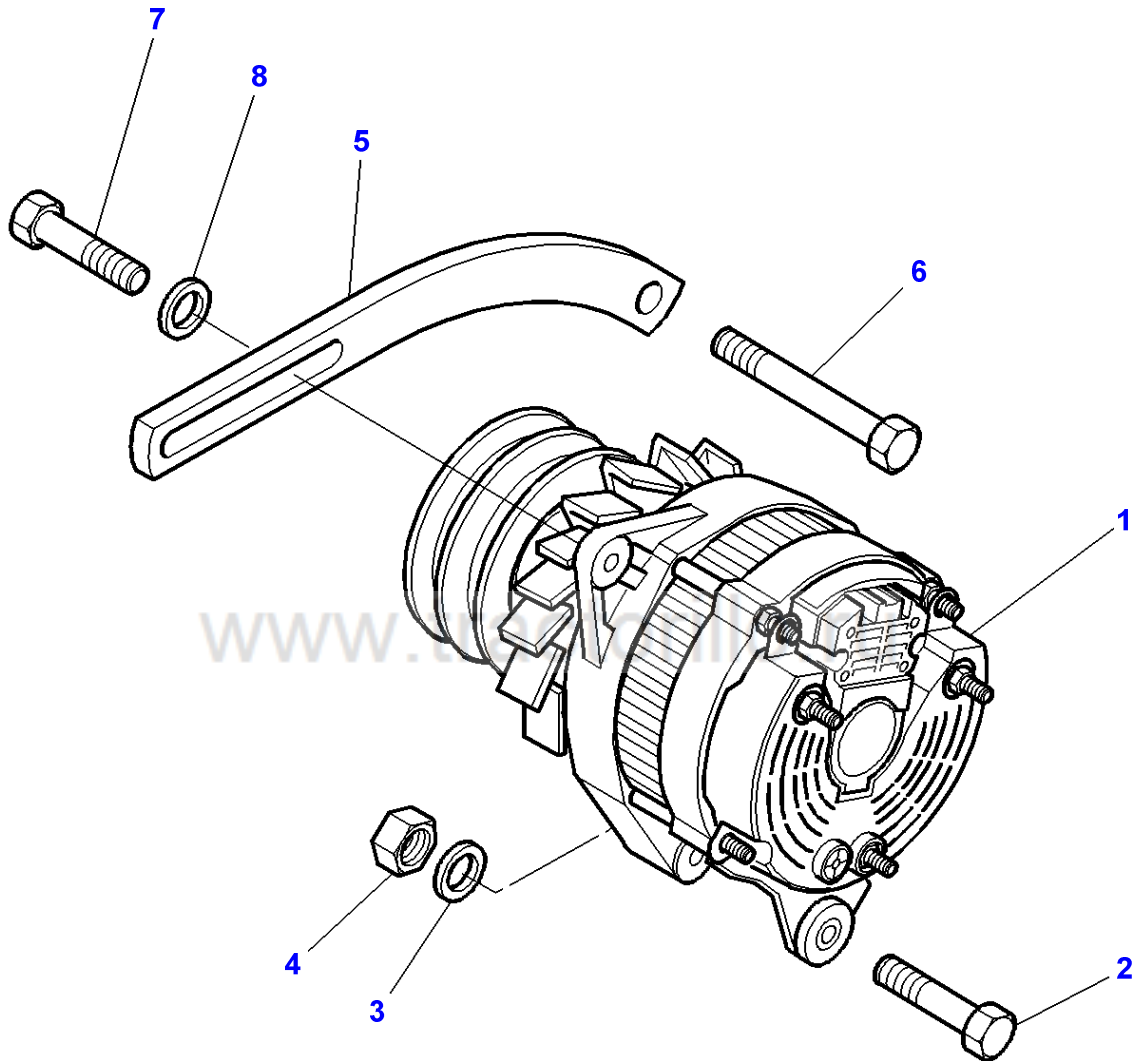

<b>Item</b>	<b>Part Number</b>	<b>Qty</b>	<b>Description</b>	<b>Comments</b>
1	3780634M1	1	Alternator	120 AMP. See Page - Reference Number 010-0020/1
2	1442487X1	1	Bolt Metric	M10 X 130
3	390734X1	1	Washer	Diameter 10-21 X 2 MM
4	339402X1	1	Nut	M10
5	3780945M1	1	Tensioner	
6	3009491X1	1	Hex. Sock. Screw	M10 X 20
7	339168X1	1	Screw	M8 X 50
8	390972X1	1	Washer Metric	Diameter 8-17 X 1,7 MM



1-ZA10-008-A

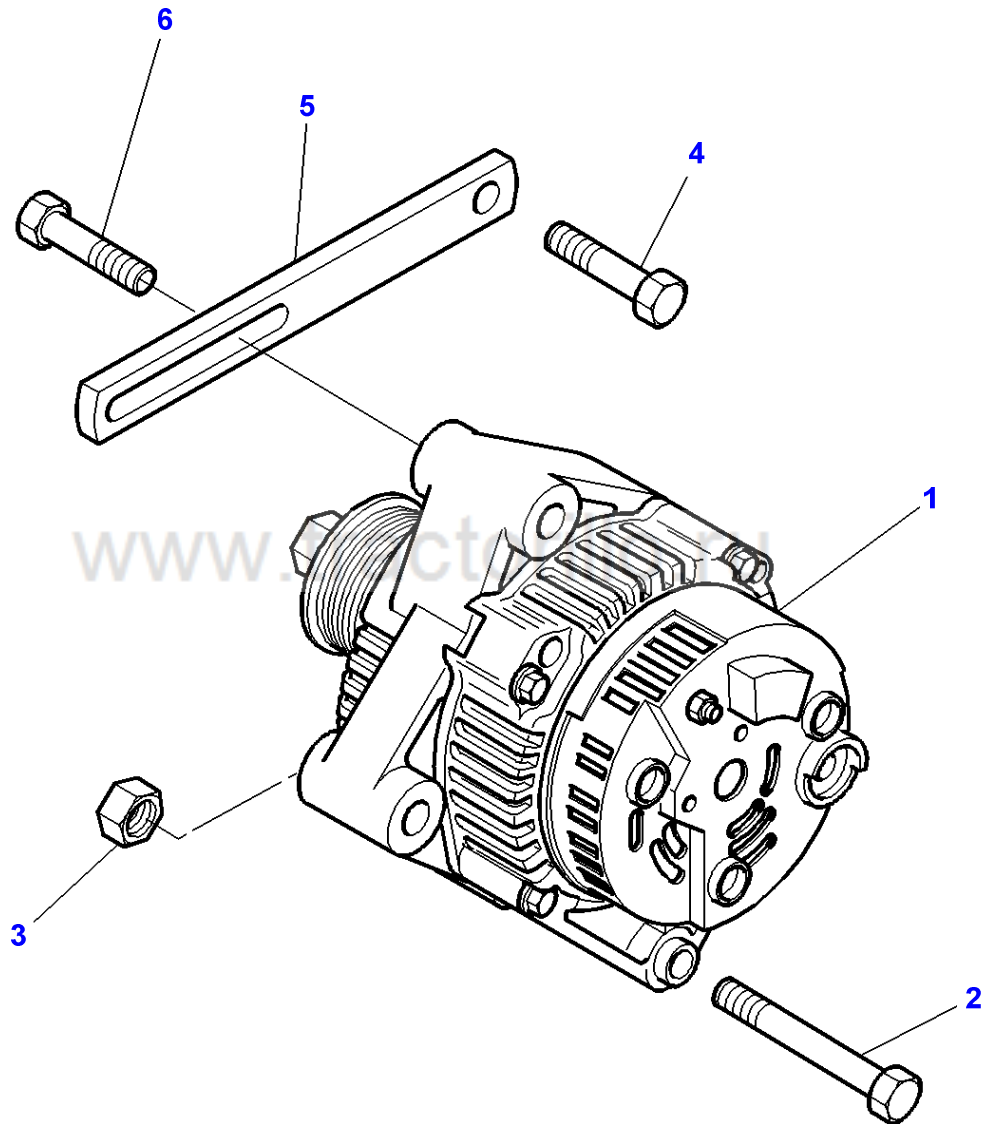

<b>Item</b>	<b>Part Number</b>	<b>Qty</b>	<b>Description</b>	<b>Comments</b>
1	3821976M92	1	Alternator	120 AMP. See Page - Reference Number 010-0025/1
2	391245X1	1	Bolt Metric	M8 X 130
3	390345X1	1	Nut Metric	M8
4	339010X1	1	Bolt Metric	M8 X 40
5	3785834M2	1	Tensioner	
6	339761X1	1	Hex. Sock. Screw	M8 X 25

FOOTNOTE [A] NOT USED

1-ZC34-001-B

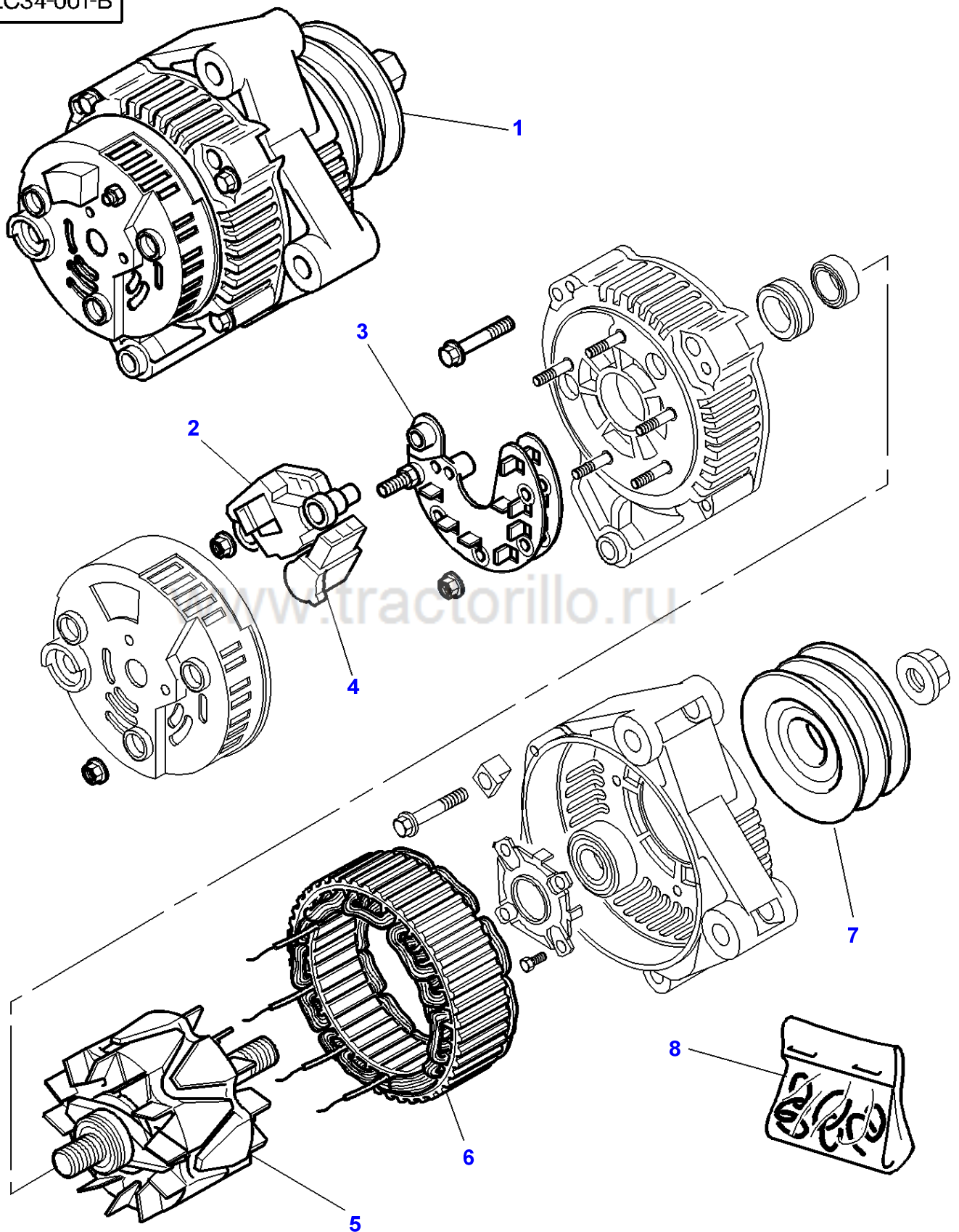

<b>Item</b>	<b>Part Number</b>	<b>Qty</b>	<b>Description</b>	<b>Comments</b>
1	3780634M1	1	Alternator	120 AMP
2	3903324M91	1	Support	(1)
3	3903321M91	1	Bridge	(1)
4	3903318M91	1	Regulator	(1)
5	3903319M91	1	Rotor	(1)
6	3903320M91	1	Stator	(1)
7	3903322M1	1	Pulley	(1)
8	3903323M91	1	Parts Pack	

1-ZC35-001-B

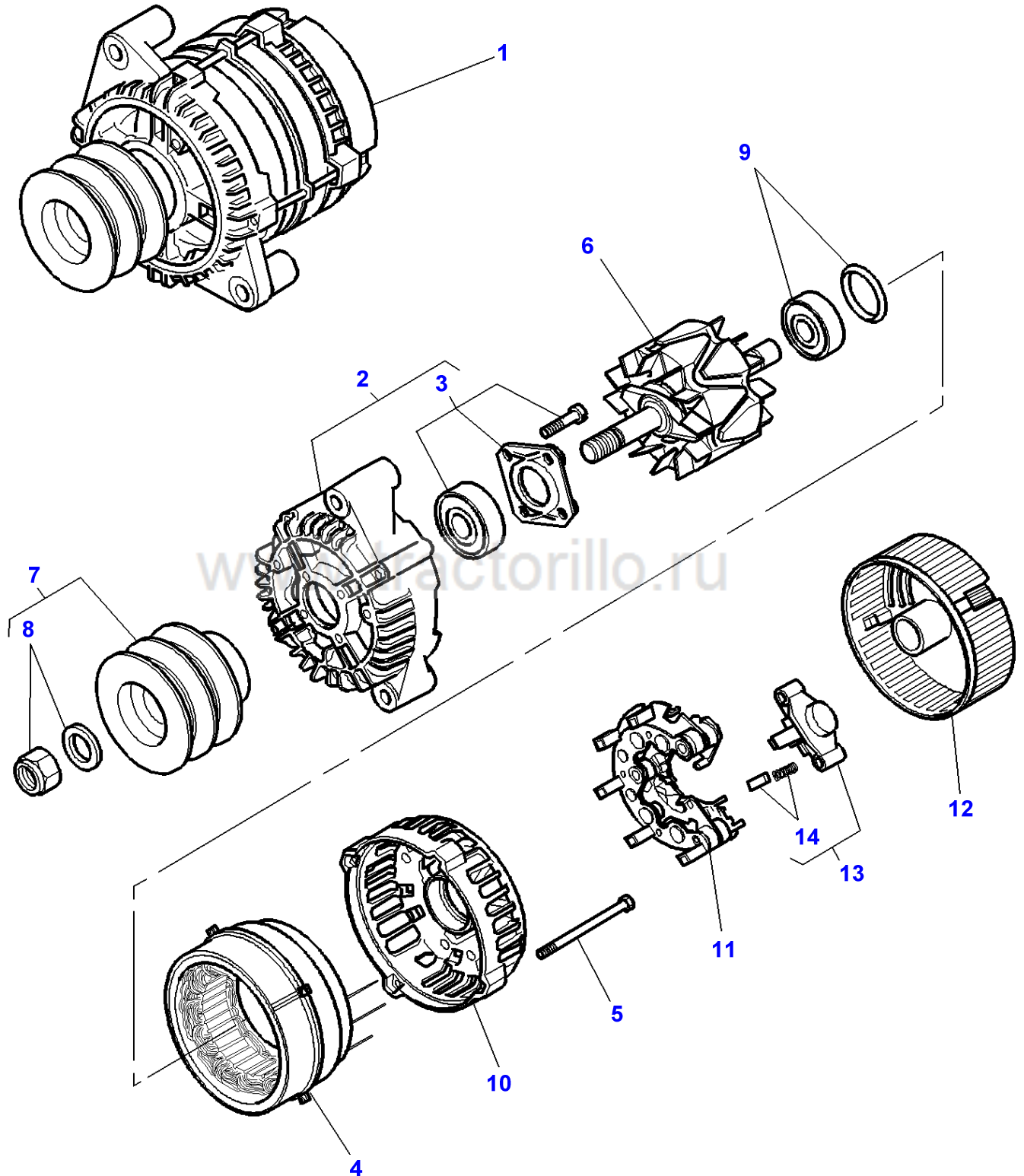

<b>Item</b>	<b>Part Number</b>	<b>Qty</b>	<b>Description</b>	<b>Comments</b>
1	3821976M92	1	Alternator	AAK-IV 120 AMP
2		1	Nose	(1) Not serviced,order REF. 1
3	3904379M91	1	Kit, Bearing	(1)
4		1	Stator	(1) Not serviced,order REF. 1
5	3904380M91	1	Kit, Bolt	(1)
6		1	Rotor	(1) Not serviced,order REF. 1
7	3823684M1	1	Pulley	(1)
8	3904381M91	1	Kit, Nut	(1)
9	3904382M91	1	Kit, Bearing	(1)
10		1	Rear Cover Assy.	(1) Not serviced,order REF. 1
11	3904383M91	1	Rectifier	(1)
12	3904384M1	1	Cover	(1)
13	3904385M91	1	Regulator	(1)
14		1	Kit, Brush	(13) Not serviced,order REF. 13



1-ZC50-002-B

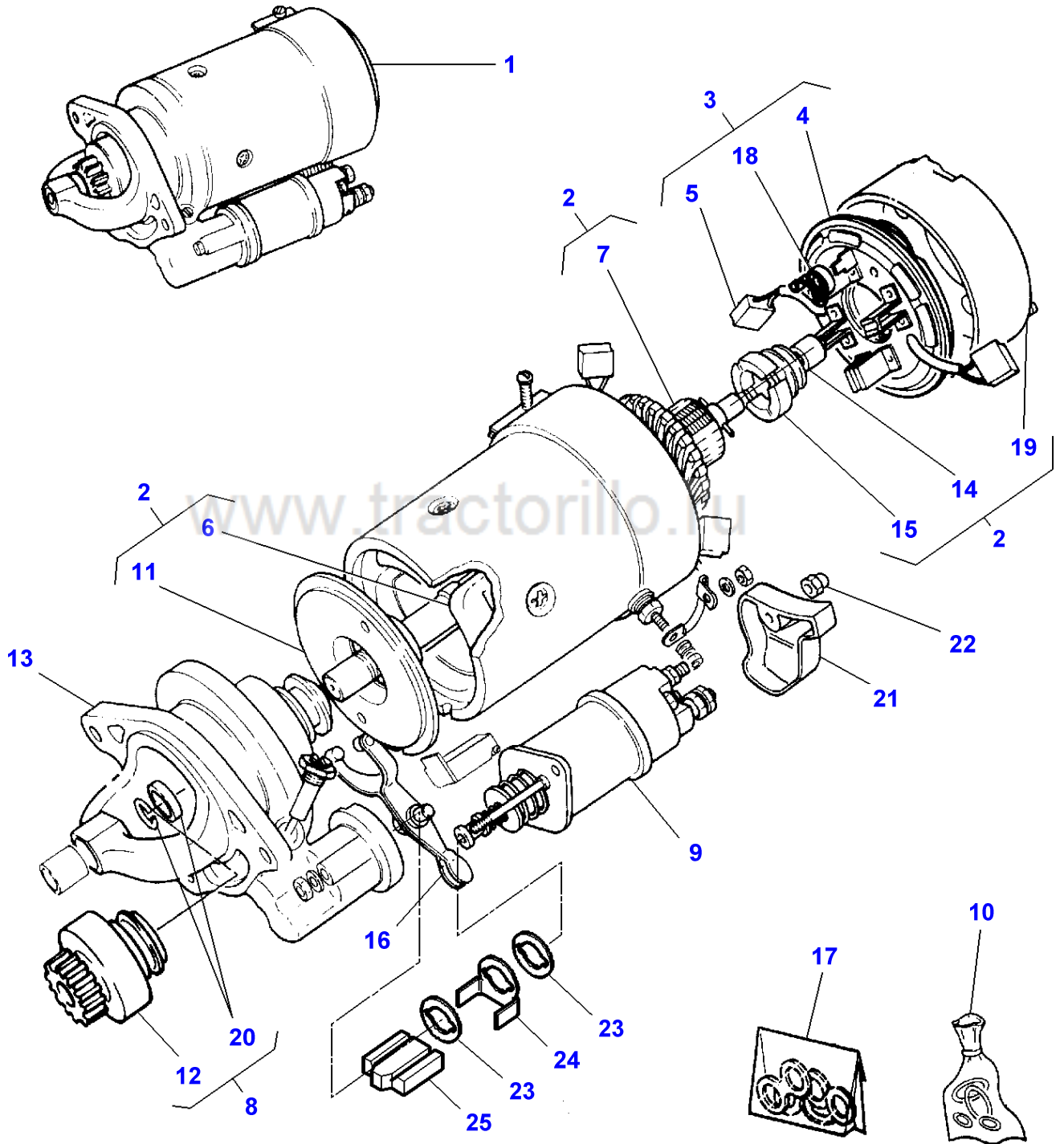

Item	Part Number	Qty	Description	Comments
1	3581576M3	1	Startermotor	[A] M127/2.8
2	3902392M91	1	Parts Pack	(1)
3	3902391M91	1	Parts Pack	(1)
4		1	Kit, Spring	(3) Not serviced,order REF NO 3
5		1	Kit, Brush	(3) Not serviced,order REF NO 3
6		1	Coil	(2) Not serviced,order REF NO 2
7		1	Armature	(2) Not serviced,order REF NO 2
8	3902390M91	1	Parts Pack	(1)
9	<b>3904281M2</b>	1	Solenoid	(1) Replace and repair. Old not interchangeable with new 3901191M1
10	1887967M91	1	Kit	(1)
11		1	Bearing Plate	(2) Not serviced,order REF NO 2
12		1	Drive	(8) Not serviced,order REF NO 8
13	3901195M91	1	Bracket	(1) Up to Serial or Engine Number H174010
	3904181M91	1	Bracket	(1) From Serial or Engine Number H174011
14		1	Bush	(2) Not serviced,order REF NO 2
15		1	Kit, Brake	(2) Not serviced,order REF NO 2
16	1897317M92	1	Kit, Lever	(1)
17	1806002M1	1	Kit, Seal	(1)
18		1	Kit, Brush Plate	(3) Not serviced,order REF NO 3
19		1	Housing	(2) Not serviced,order REF NO 2
20		1	Kit, Retainer	(8) Not serviced,order REF NO 8
21	3611662M1	1	Cover	
22	3611638M1	1	Nut	
23	3904186M1	2	Gasket	(1) From Serial or Engine Number H174011
24	3904185M1	1	Carrier	(1) From Serial or Engine Number H174011
25	3904184M1	1	Grommet	(1) From Serial or Engine Number H174011

**FOOTNOTE [A]** THE APPROPRIATE SAFETY DECALS MUST BE ORDERED AND FITTED TO THIS PART

1-ZC51-002-B

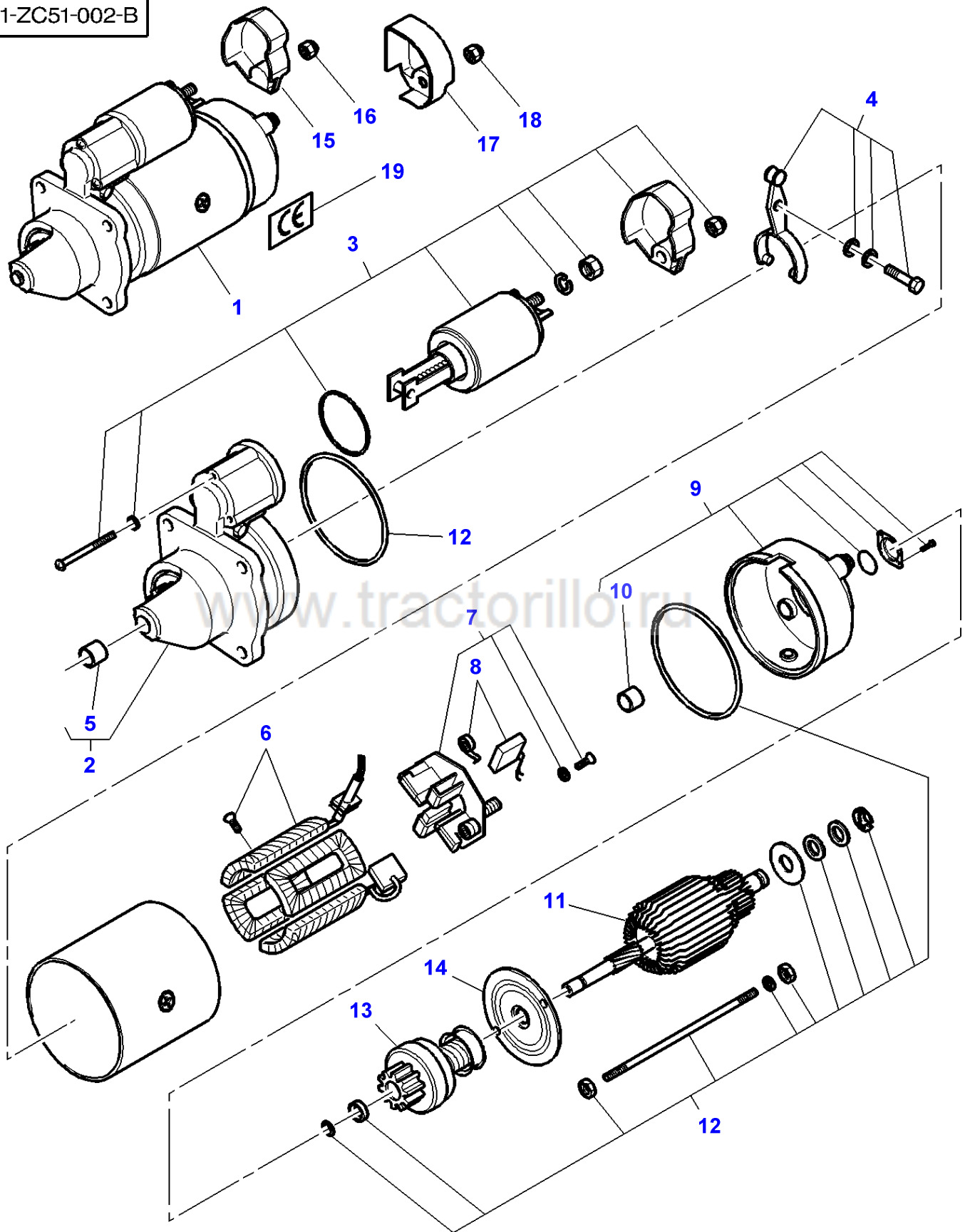

Item	Part Number	Qty	Description	Comments
1	3784889M2	1	Startermotor	[A] 3 KW
2	3903758M91	1	Bracket	(1)
3	3903759M92	1	Solenoid	(1)
4	3903760M91	1	Kit, Lever	(1)
5	3903761M1	1	Bearing	(2)
6	3903762M91	1	Coil	(1)
7	3903763M91	1	Kit, Brush Plate	(1)
8	3903764M91	1	Kit, Brush	(7)
9	3903765M91	1	Housing	(1)
10	3903766M1	1	Bearing	(9)
11	3903767M91	1	Armature	(1)
12	3903770M91	1	Impeller Hub	(1)
13	3903768M91	1	Parts Pack	(1)
14	3903769M91	1	Cover	(1)
15	3786090M1	1	Protector	Up to Serial or Engine Number K249035
16	3786089M1	1	Nut	Up to Serial or Engine Number K249035 M8
17	3786093M1	1	Protector	From Serial or Engine Number K249036
18	3786092M1	1	Nut	From Serial or Engine Number K249036 M10
19	3788193M1	1	Label	

**FOOTNOTE [A]** THE APPROPRIATE SAFETY DECALS MUST BE ORDERED AND FITTED TO THIS PART

MF 8250 TRACTOR - 1637366  
1-ZH01-004-B

1-ZH01-004-B

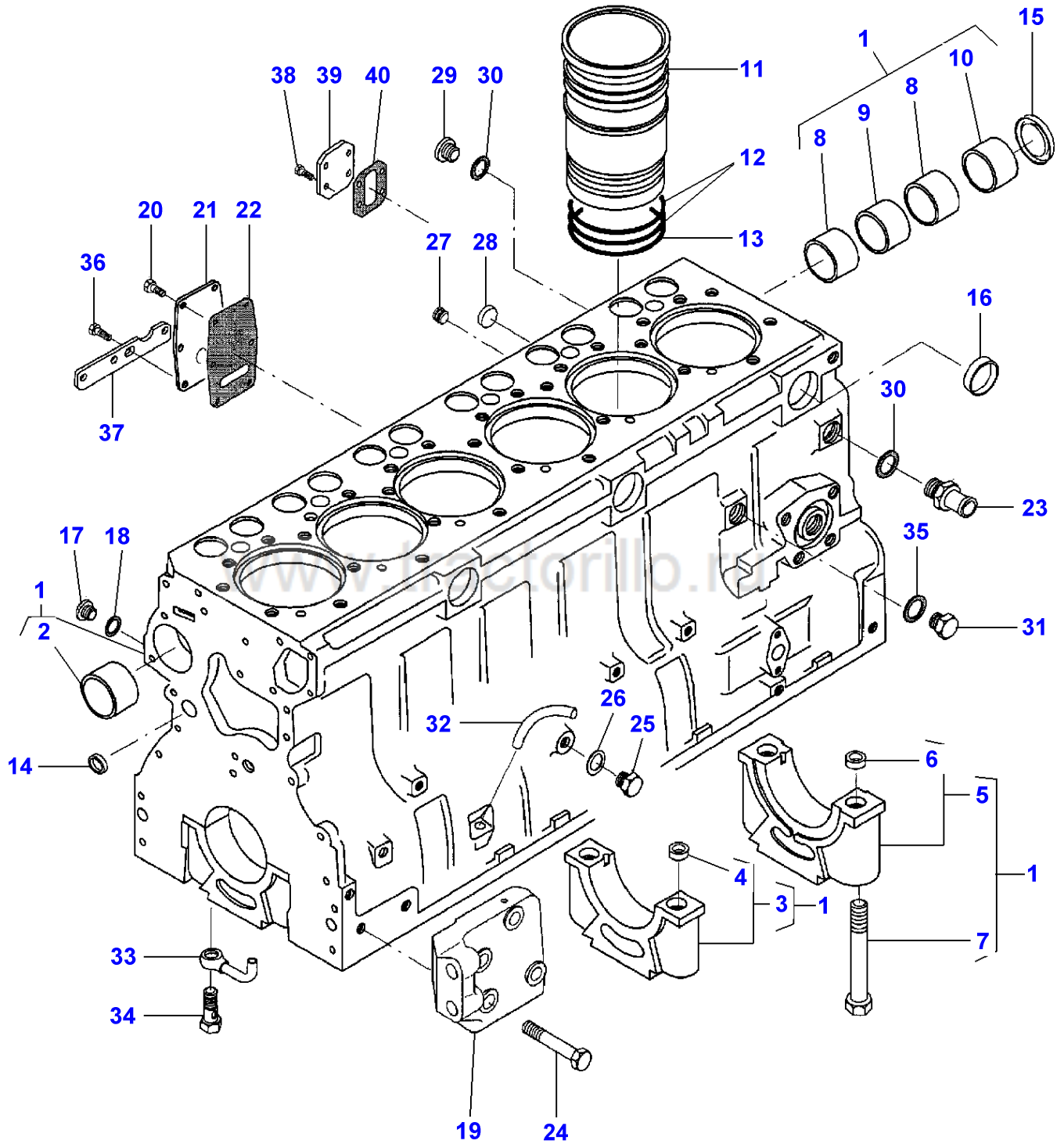

Cylinder Block

Item	Part Number	Qty	Description	Comments
1	V836847275	1	Cylinder Block	MF 8250
	V836866110	1	Cylinder Block	MF 8250 XTRA
2	V836322610	1	Bush	(1) MF 8250
	V836866069	1	Bush	(1) MF 8250 XTRA
	V836866036	X	Bush	MF 8250 XTRA Diameter +0.4MM
3		6	Bearing Carrier	(1)
4	V836214478	2	Bush	(3)
5		1	Bearing Carrier	(1)
6	V836214478	2	Bush	(5)
7	V529903180	14	Screw	(1)
8	V836852460	2	Bush	(1)
9	V836852459	1	Bush	(1)
10	V836852461	1	Bush	(1)
11	V836647420	6	Liner	
	V836647933	X	Liner	Thickness 9,08MM
	V836647934	X	Liner	Thickness 9,13MM
	V836647935	X	Liner	Thickness 9,23MM
12	V836647502	12	O Ring	
13	V836647503	6	O Ring	
14	V640016016	4	Plug	
15	V836852744	1	Plug	
16	V640016040	3	Plug	
17	V640325110	3	Plug	
18	V615571014	4	Seal	
19	V836852656	1	Support	Up to Serial or Engine Number K xxxx Left Hand
	V836864529	1	Support	From Serial or Engine Number K xxxx Left Hand
	V836852657	1	Support	Up to Serial or Engine Number K xxxx Right Hand
	V836864530	1	Support	From Serial or Engine Number K xxxx Right Hand
20	V528801380	4	Screw	M8X20
21	V836847994	1	Cover	
22	V836322852	1	Gasket	
23	V836119837	1	Union	
24	V529802682	8	Screw	MF 8250 M14 X 65
	V529902680	8	Screw	MF 8250 XTRA M14 X 65
25	V640305012	1	Plug	
26	V615881216	1	Gasket	
27	V640025010	1	Plug	
28	V640016018	3	Plug	
29	V640325018	1	Plug	
30	V615881822	2	Seal	
31	V836019756	1	Plug	
32	V836855997	1	Pipe	
33	V836855093	6	Pipe	
34	V836338601	6	Valve	
35	V615881824	1	Seal	
36	V528801400	2	Screw	M8X25
37	V836859571	1	Support	
38	V528801362	4	Screw	M8X16
39	V836659543	1	Cover	
40	V836659544	1	Gasket	