

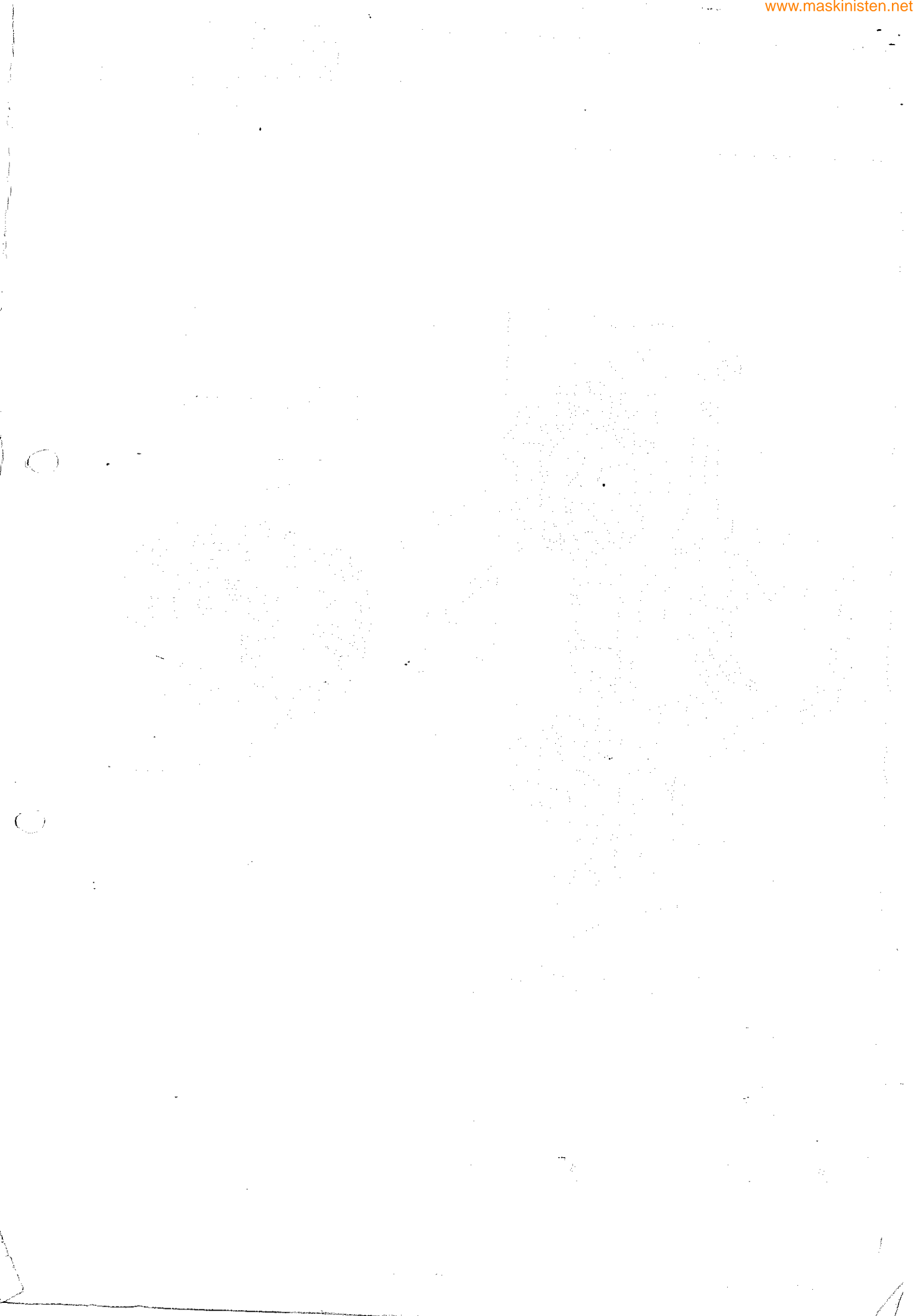

REF. 47961

MVT 730
T.U.V.
PARTS CATALOGUE

04-94



FINO ALLA MACCHINA
JUSQU'A LA MACHINE
UP TO MACHINE

→ N° 4511 - 97621

MVT730 -

1

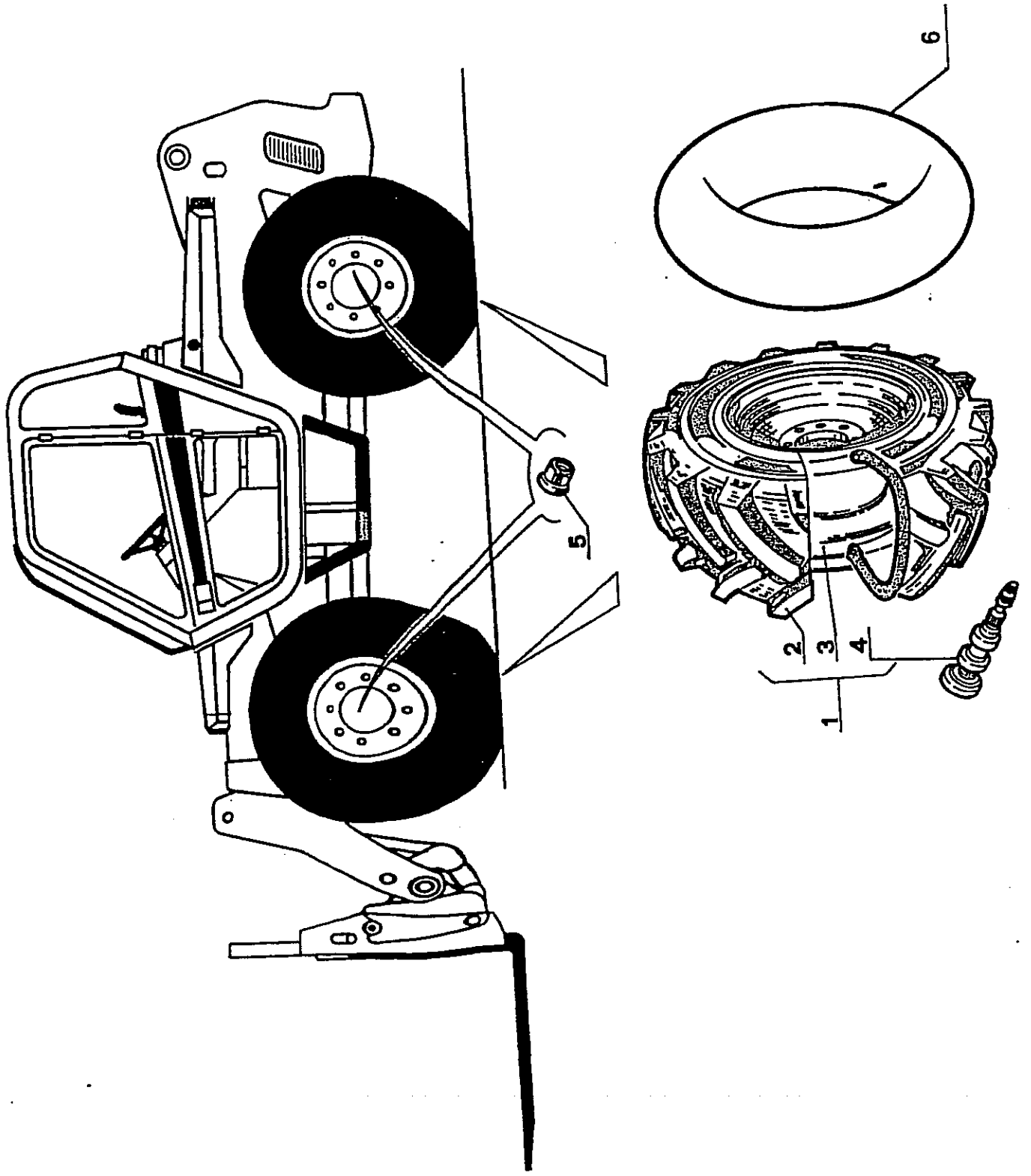

1/1		WHEEL RUOTE ROUES	1	
			Qty - Q.te Quantità	
Ref. Rif. Rep.	Part Number	Description Descrizione Designation	MVT 730	
1	487 301	Right complete wheel - Ruota completa dx - Roue droite complète	2	
	487 516	Left complete wheel - Ruota completa sx - Roue gauche complète	2	
2	484 373	Wheel stripped - Pneumatico Dunlop - Roue nu	4	
3	487 297	Tyre - Cerchione - Enveloppe	4	
4	448 015	Complete valve - Valvola completa - Valve complete	4	
5	486 690	Nut - Dado - Erou	32	
6	455 005	Tube - Camera d'aria - Chambre a air	4	

1/A

A PARTIRE DALLA MACCHINA
A PARTIR DE LA MACHINE
FROM MACHINE

→ N° 4521 - 96416

MVT730

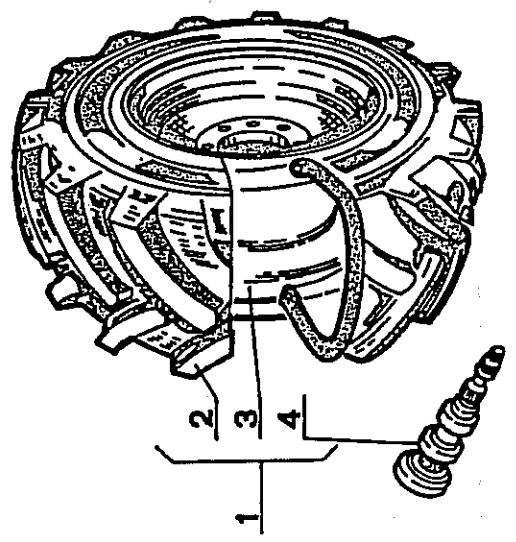
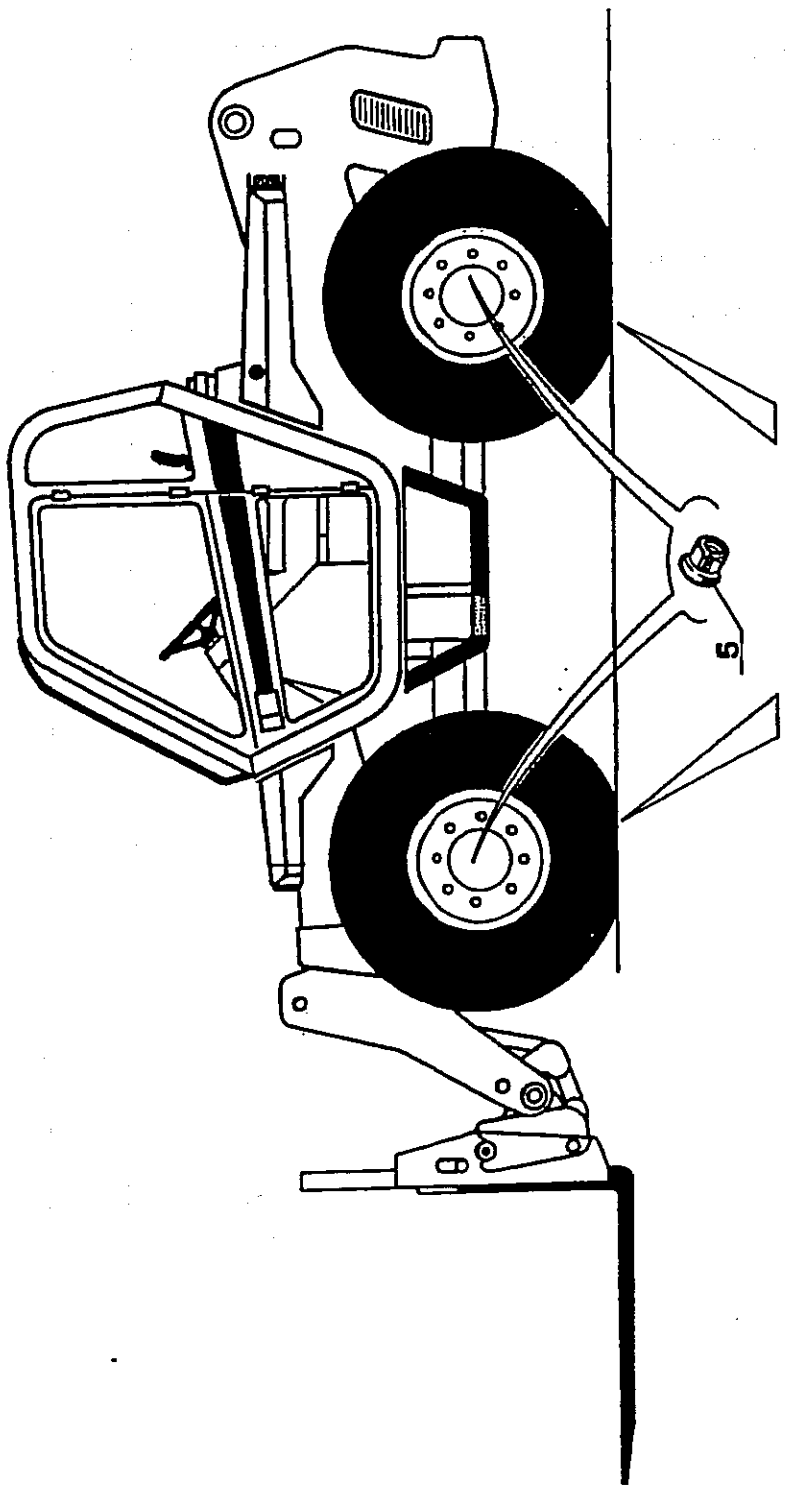

1/1	WHEEL RUOTE ROUES		1/A
			Qty - Q.te Quantità
Ref. Rif. Rep.	Part Number	Description Descrizione Designation	MVT 730
1	487 301	Right complete wheel - Ruota completa dx - Roue droite complète	2
	487 516	Left complete wheel - Ruota completa sx - Roue gauche complète	2
2	484 373	Wheel stripped - Pneumatico Dunlop - Roue nu	4
3	487 297	Tyre - Cerchione - Enveloppe	4
4	487 222	Valve - Valvola - Valve	4
5	486 690	Nut - Dado - Ecrou	32

FINO ALLA MACCHINA
JUSQUA LA MACHINE
UP TO MACHINE

MVT 730

➔ N° 4497 - 95937

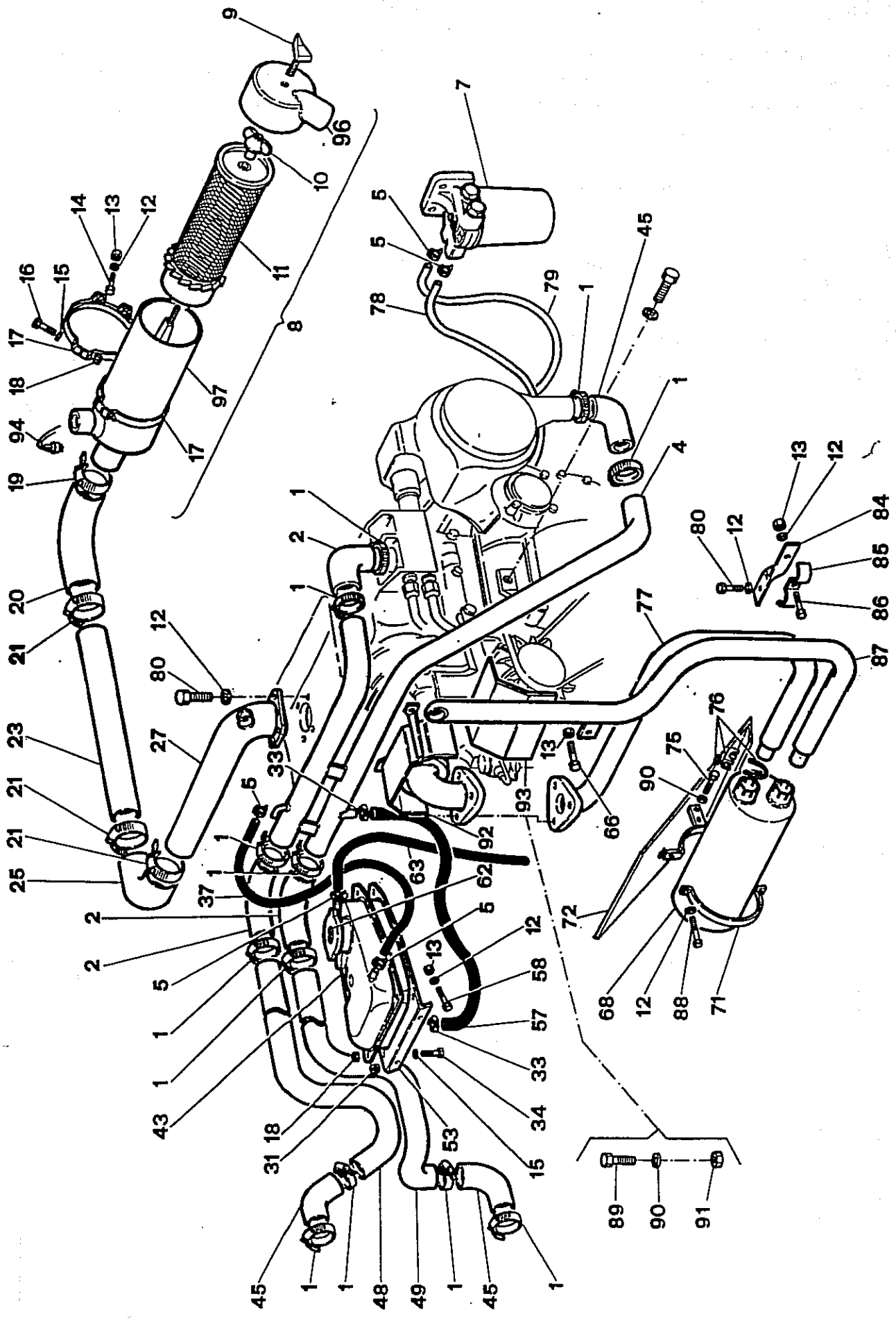

1/2	ENGINE AND POWER SHIFT COOLING SYSTEM, AIR FILTER AND EXHAUST RAFFREDDAMENTO MOTORE E CAMBIO, SCARICO FILTRO ARIA REFROIDISSEMENT DU MOTEUR ET POWER SHIFT, POT D'ECHAPPEMENT ET FILTRE AIR			2		
				Qty - Q.te Quantità		
Ref. Rif. Rep.	Part Number	Description Descrizione Designation	MVT 730			
1	448 026	Clamp - fascetta - Collier	12			
2	485 621	Hose - Manicotto - Durit	3			
4	487 799	Pipes - Tubi - Tuyaux	1			
5	448 871	Clamp - Fascetta - Collier	5			
7	473 559	Fuel prefilter - Prefiltro gasolio - Prefiltre	1			
8	455 043	Complete air filter - Filtro aria completo - Filtre air complet	1			
9	499 939	Screw - Vite - Vis	1			
10	499 936	Wing nut - Dado ad alette - Ecrou à papillon	1			
11	455 044	Filtre cartridge - cartuccia - Cartouche	1			
12	448 285	Washer - Rondella - Rondelle	15			
13	471 320	Nut - Dado aut. M8 - Ecrou	12			
14	470 388	Screw - vite TE 8X16 - Vis	5			
15	455 018	Washer - Rondella - rondelle	5			
16	478 639	Screw - Vite (TE M6X50) - Vis	2			
17	499 937	Clamp - Collare - Collier	2			
18	471 402	Nut - Dado aut. M6 - Ecrou	5			
19	470 680	Clamp - Fascetta - Collier	1			
20	455 049	Hose - Manicotto - Durit	1			
21	479 030	Clamp - fascetta - Collier	5			
23	485 651	Pipe - Tubo - Tuyau	1			
25	470 094	Hose - Manicotto - Durit	2			
27	487 305	Pipe - Tubo - Tuyau	1			
31	487 789	Spacer - Distanziale - Entretoise	3			
33	480 283	Clamp - fascetta - Collier	2			
34	487 815	Screw - Vite TE M6X35 - Vis	3			
37	485 969	Hose - Tubo Durit	1			
43	484 717	Tank - Serbatoio - Reservoir	1			
45	485 627	Hose - Manicotto - Durit	3			
48	486 106	Pipe - Tubo - Tuyau	1			
49	486 107	Pipe - Tubo - Tuyau	1			
53	485 574	Bracket - Supporto - Support	1			

2/2	ENGINE AND POWER SHIFT COOLING SYSTEM, AIR FILTER AND EXHAUST RAFFREDDAMENTO MOTORE E CAMBIO, SCARICO FILTRO ARIA REFROIDISSEMENT DU MOTEUR ET POWER SHIFT, POT D'ECHAPPEMENT ET FILTRE AIR			2	
	Ref. Rif. Rep.	Part Number	Description Descrizione Designation	MVT 730	Qty - Q.te Quantità
57	486 269	Pipe - Tubo - Tuyau	1		
58	471 349	Screw - Vite - Vis (TE M8X25)	2		
62	485 560	Plug - Tappo - Bouchon	1		
63	485 968	Pipe - Tubo - Tuyau	1		
66	471 338	Screw - Vite - Vis (TE M8X35)	1		
68	79305	Muffler - Silenziatore - pot d'echappement	1		
71	486 109	Clamp - Collare sup - Collier	1		
72	487 794	Clamp - Collare inf - Collier	1		
75	478 861	Screw - vite - Vis (TE M10X25)	2		
76	485 831	Clamp - Fascetta - Collier	2		
77	487 306	Pipe - Tubo - Tuyau	1		
78	499 291	Pipe - Tubo - Tuyau	1		
79	485 935	Pipe - Tubo - Tuyau	1		
80	448 677	Screw - Vite - Vis (TE M8X20)	5		
84	487 308	Bracket - Supporto - Support	1		
85	486 115	Flask - Staffa - Bride	3		
86	478 560	Screw - Vite - Vis (TE M8X80)	1		
87	487 307	Hose - Tubo - Tube	1		
88	482 869	Screw - Vite - Vis (M8X60)	2		
89	471 365	Screw - Vite - Vis (M10 X 40)	3		
90	471 326	Washer - Rondella - Rondelle	3		
91	471 325	Nut - dado - Ecrou (M10)	3		
92	487 800	Casing - carter - Tôle de fermeture	1		
93	487 796	Casing - carter - Tôle de fermeture	1		
94	448 035	Indicateur - Indicatore - Indicateur	1		
96		Not sold separately - Non fornito separatamente - Pas fourni sepa- rement			
97		Not sold separately - Non fornito separatamente - Pas fourni sepa- rement			

2/A

A PARTIRE DALLA MACCHINA
A PARTIR DE LA MACHINE
FROM MACHINE

➔ N° 4510 - 97620

FINO ALLA MACCHINA
JUSQU'A LA MACHINE
UP TO MACHINE

➔ N° 4526 - 96419

MVT 730

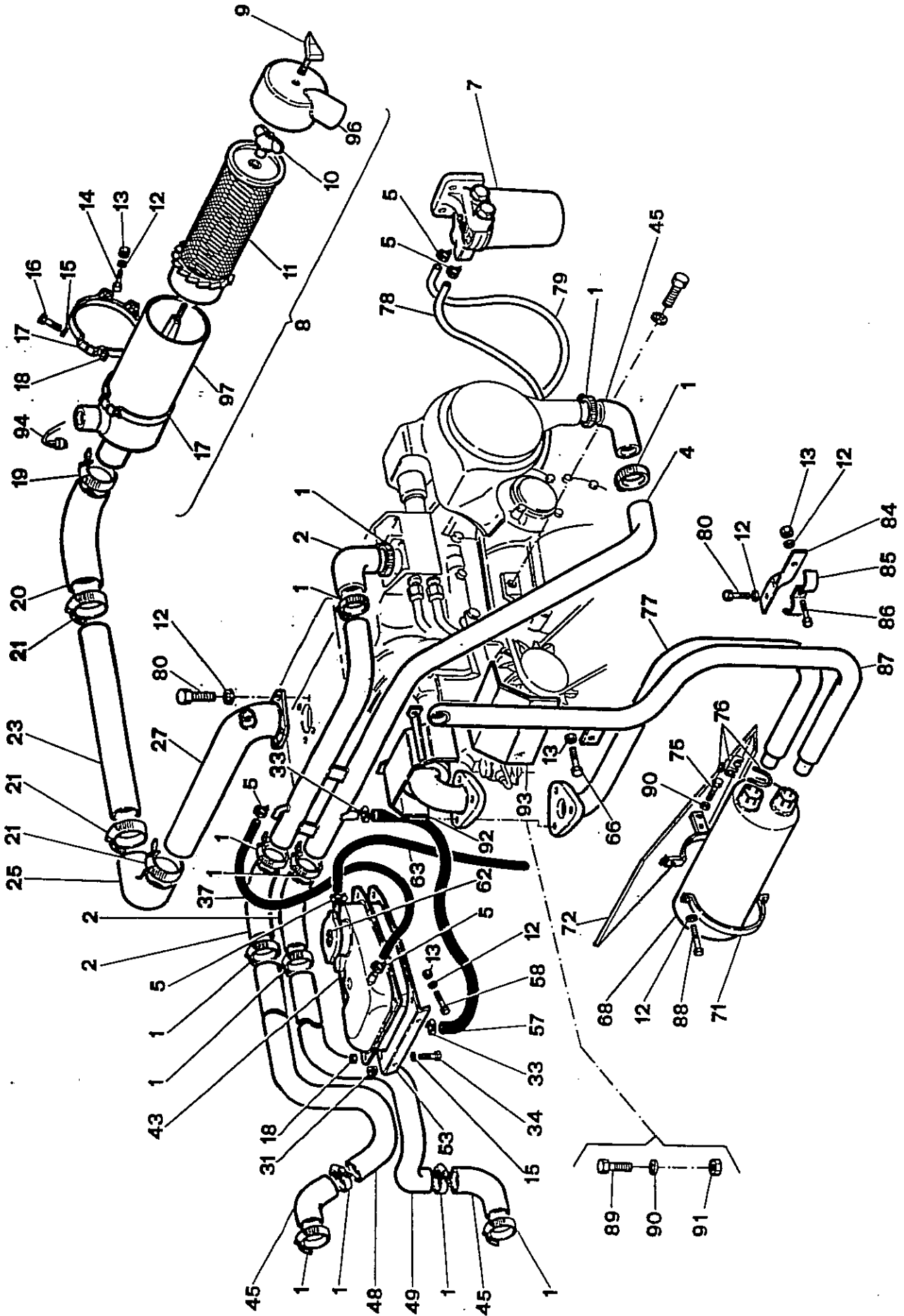

1/2	ENGINE AND POWER SHIFT COOLING SYSTEM, AIR FILTER AND EXHAUST RAFFREDDAMENTO MOTORE E CAMBIO, SCARICO FILTRO ARIA REFROIDISSEMENT DU MOTEUR ET POWER SHIFT, POT D'ECHAPPEMENT ET FILTRE AIR		2/A		
			Qty - Q.te Quantità		
Ref. Rif. Rep.	Part Number	Description Descrizione Designation	MVT 730		
1	448 026	Clamp - fascetta - Collier	12		
2	485 621	Hose - Manicotto - Durit	3		
4	487 799	Pipes - Tubi - Tuyaux	1		
5	448 871	Clamp - Fascetta - Collier	5		
7	473 559	Fuel prefilter - Prefiltro gasolio - Prefiltre	1		
8	499 350	Complete air filter - Filtro aria completo - Filtre air complet	1		
9	499 939	Screw - Vite - Vis	1		
10	499 936	Wing nut - Dado ad alette - Ecrou à papillon	1		
11	499 935	Filtre cartridge - cartuccia - Cartouche	1		
12	448 285	Washer - Rondella - Rondelle	15		
13	471 320	Nut - Dado aut. M8 - Ecrou	12		
14	470 388	Screw - vite TE 8X16 - Vis	5		
15	455 018	Washer - Rondella - rondelle	5		
16	478 639	Screw - Vite (TE M6X50) - Vis	2		
17	499 937	Clamp - Collare - Collier	2		
18	471 402	Nut - Dado aut. M6 - Ecrou	5		
19	470 680	Clamp - Fascetta - Collier	1		
20	455 049	Hose - Manicotto - Durit	1		
21	479 030	Clamp - fascetta - Collier	5		
23	485 651	Pipe - Tubo - Tuyau	1		
25	470 094	Hose - Manicotto - Durit	2		
27	487 305	Pipe - Tubo - Tuyau	1		
31	487 789	Spacer - Distanziale - Entretoise	3		
33	480 283	Clamp - fascetta - Collier	2		
34	487 815	Screw - Vite TE M6X35 - Vis	3		
37	485 969	Hose - Tubo Durit	1		
43	484 717	Tank - Serbatoio - Reservoir	1		
45	485 627	Hose - Manicotto - Durit	3		
48	486 106	Pipe - Tubo - Tuyau	1		
49	486 107	Pipe - Tubo - Tuyau	1		
53	485 574	Bracket - Supporto - Support	1		

2/2	ENGINE AND POWER SHIFT COOLING SYSTEM, AIR FILTER AND EXHAUST RAFFREDDAMENTO MOTORE E CAMBIO, SCARICO FILTRO ARIA REFROIDISSEMENT DU MOTEUR ET POWER SHIFT, POT D'ECHAPPEMENT ET FILTRE AIR		2 / A		
	Ref. Rif. Rep.	Part Number	Description Descrizione Designation	MVT 730	Qty - Q.te Quantità
57	486 269	Pipe - Tubo - Tuyau	1		
58	471 349	Screw - Vite - Vis (TE M8X25)	2		
62	485 560	Plug - Tappo - Bouchon	1		
63	485 968	Pipe - Tubo - Tuyau	1		
66	471 338	Screw - Vite - Vis (TE M8X35)	1		
68	79305	Muffler - Silenziatore - pot d'echappement	1		
71	486 109	Clamp - Collare sup - Collier	1		
72	487 794	Clamp - Collare inf - Collier	1		
75	478 861	Screw - vite - Vis (TE M10X25)	2		
76	485 831	Clamp - Fascetta - Collier	2		
77	487 306	Pipe - Tubo - Tuyau	1		
78	499 291	Pipe - Tubo - Tuyau	1		
79	485 935	Pipe - Tubo - Tuyau	1		
80	448 677	Screw - Vite - Vis (TE M8X20)	5		
84	487 308	Bracket - Supporto - Support	1		
85	486 115	Flask - Staffa - Bride	3		
86	478 560	Screw - Vite - Vis (TE M8X80)	1		
87	487 307	Hose - Tubo - Tube	1		
88	482 869	Screw - Vite - Vis (M8X60)	2		
89	471 365	Screw - Vite - Vis (M10 X 40)	3		
90	471 326	Washer - Rondella - Rondelle	3		
91	471 325	Nut - dado - Ecrou (M10)	3		
92	487 800	Casing - carter - Tôle de fermeture	1		
93	487 796	Casing - carter - Tôle de fermeture	1		
94	499 941	Indicateur - Indicatore - Indicateur	1		
96	499 938	Cap - Coperchio filtro - Couvercle du filtre	1		
97	499 934	Filter-body - Corpo filtro - Corps du filtre	1		

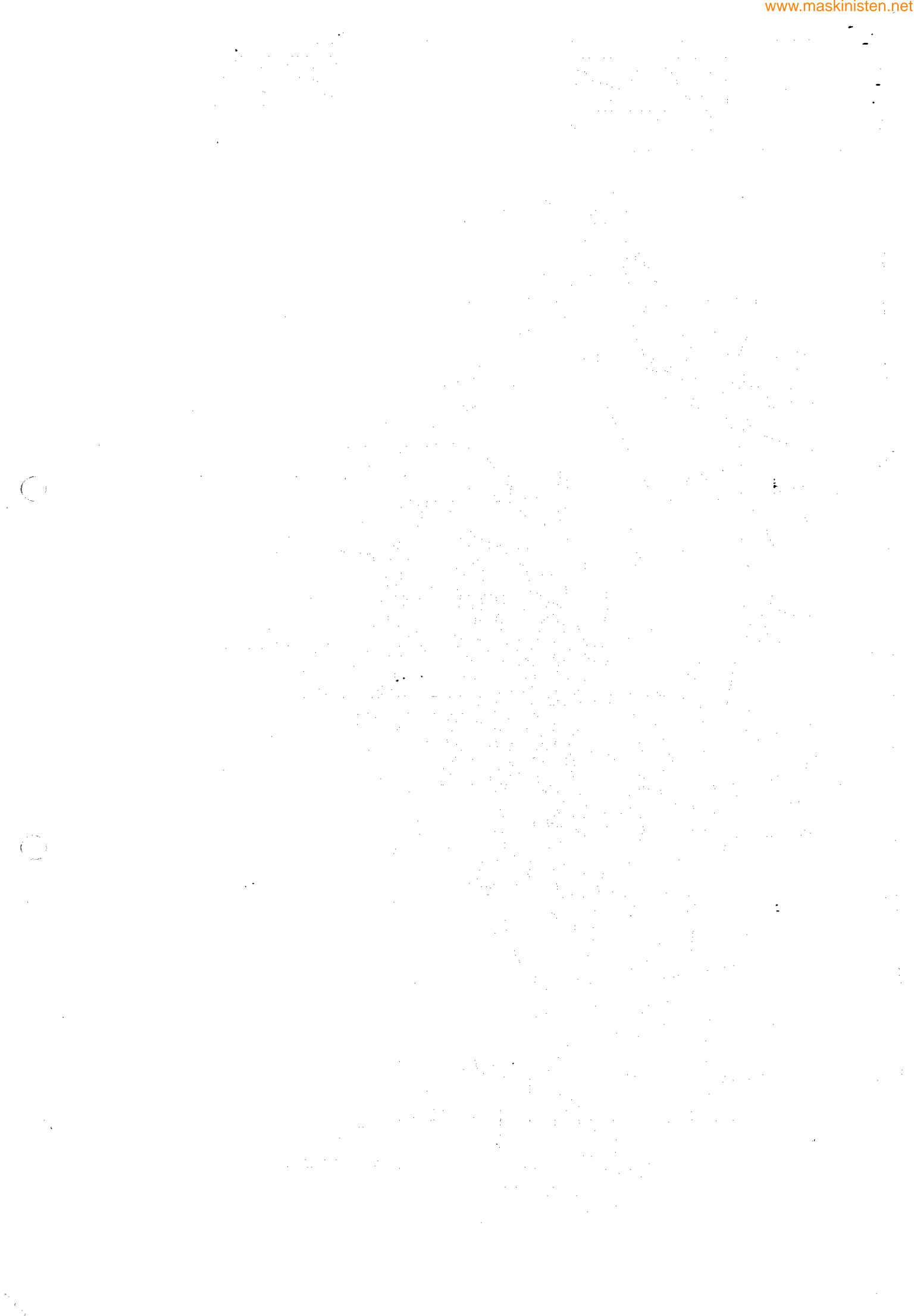

2/B

A PARTIRE DALLA MACCHINA
A PARTIR DE LA MACHINE
FROM MACHINE

→ N° 4564 - 96497

FINO ALLA MACCHINA
JUSQU'A LA MACHINE
UP TO MACHINE

→ N° 4610 - 97221

MVT 730

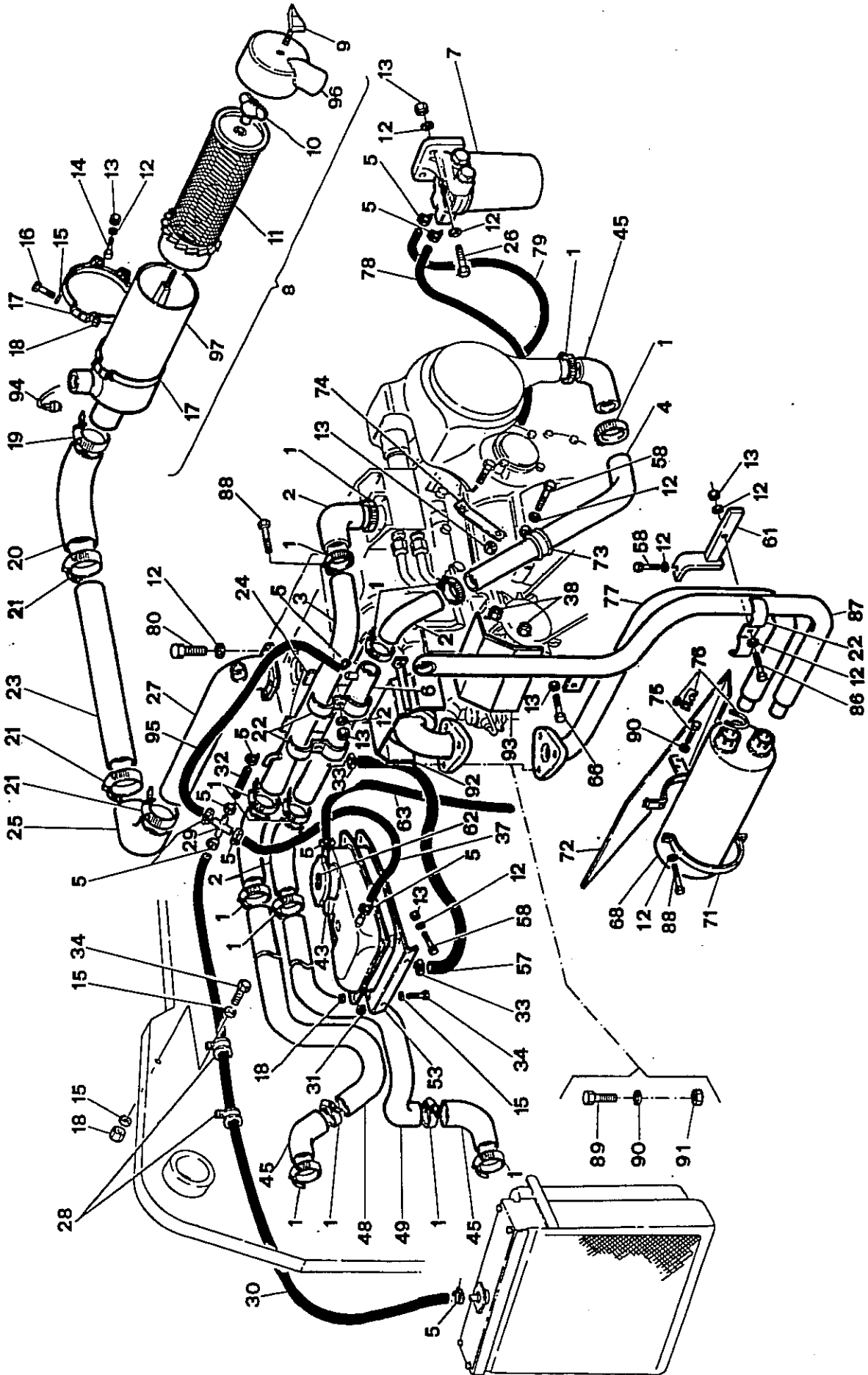

1/3	ENGINE AND POWER SHIFT COOLING SYSTEM, AIR FILTER AND EXHAUST RAFFREDDAMENTO MOTORE E CAMBIO, SCARICO FILTRO ARIA REFROIDISSEMENT DU MOTEUR ET POWER SHIFT, POT D'ECHAPPEMENT ET FILTRE AIR		2/B		
			Qty - Q.te Quantità		
Ref. Rif. Rep.	Part Number	Description Descrizione Designation	MVT 730		
1	479 159	Clamp - fascetta - Collier	13		
2	488 359	Hose - manicotto - Durit	4		
3	499 614	Pipe - Tubo - Tuyau	1		
4	499 254	Pipe - Tubo - Tuyau	1		
5	487 909	Clamp - Fascetta - Collier	11		
6	499 615	Pipe - Tubo - Tuyau	1		
7	473 559	Fuel prefilter - Prefiltro - Prefiltre	1		
8	499 350	Complete filter air - Filtro aria compl; - Filtre air complet	1		
9	499 939	Screw - Vite - Vis	1		
10	499 936	Nut - Dado - Erou	1		
11	499 935	Filter cartridge - cartuccia - Cartouche	1		
12	448 285	Washer - Rondella - Rondelle	18		
13	471 320	Nut - Dado aut. M8 - Erou	14		
14	470 388	Screw - Vite - Vis (TE M8X16)	4		
15	455 018	Washer - Rondella - Rondelle	9		
16	478 639	Screw - Vite - Vis (TE M6X50)	2		
17	499 937	Clamp - Collare - Collier	2		
18	471 402	Nut - Dado aut. M6 - Erou	7		
19	470 680	Clamp - Fascetta - Collier	1		
20	455 049	Hose - Manicotto - Durit	1		
21	479 030	Clamp - Fascetta - Collier	3		
22	486 115	Clamp - Collare - Collier	3		
23	485 651	Pipe - Tubo - Tuyau	1		
24	487 823	Flask - Staffa - bride	2		
25	470 094	Hose - Manicotto - durit	1		
26	471 363	Screw - Vite - Vis (TE M8X30)	2		
27	487 305	Pipe - Tubo - tuyau	1		
28	486 949	Clamp - Fascetta - Collier	4		
29	499 536	Connector - Raccordo - Raccord	1		
30	499 619	Pipe - Tubo - Tuyau	1		
31	487 789	Spacer - Distanziale - Entretoise	3		

2/3	ENGINE AND POWER SHIFT COOLING SYSTEM, AIR FILTER AND EXHAUST RAFFREDDAMENTO MOTORE E CAMBIO, SCARICO FILTRO ARIA REFROIDISSEMENT DU MOTEUR ET POWER SHIFT, POT D'ECHAPPEMENT ET FILTRE AIR		2/B		
			Qty - Q.te Quantità		
Ref. Rif. Rep.	Part Number	Description Descrizione Designation	MVT 730		
32	499 618	Pipe - Tubo - Tuyau	1		
33	480 283	Clamp - fascetta - Collier	2		
34	487 815	Screw - Vite - Vis (TE M6X35)	5		
37	485 969	Pipe - Tubo - Tuyau	1		
38	479 803	Nut - Dado es. M5 - Ecrou	2		
43	484 717	Tank - Serbatoio - Reservoir	1		
45	485 627	Hose - Manicotto - Durit	3		
48	486 106	Hose - Tubo - Tuyau	1		
49	486 107	Hose - Tubo - Tuyau	1		
53	485 574	Bracket - Supporto - Support	1		
57	486 269	Pipe - Tubo - Tuyau	1		
58	471 349	Screw - Vite - Vis (TE M8X25)	4		
61	487 308	flask - Staffa - Bride	1		
62	485 560	Plug - Tappo - Bouchon	1		
63	485 968	Pipe - Tubo - Tuyau	1		
66	471 378	Screw - Vite - Vis (TE M8X35)	1		
68	79305	Muffler - Silenziatore - Pot d'echappement	1		
71	486 109	Clamp - Collare - Collier	1		
72	487 794	Clamp - Collare sup. - Collier	1		
73	488 253	Clamp - fascetta - Collier	1		
74	499 259	Palte - Piatto - Plaque	1		
75	478 861	Screw - Vite - Vis (TE M10X25)	2		
76	485 831	Clamp - Fascetta - Collier	2		
77	487 306	Pipe - Tubo - Tuyau	1		
78	499 291	Pipe - Tubo - Tuyau	1		
79	485 935	Pipe - Tubo - Tuyau	1		
80	448 677	Screw - Vite - Vis (TE M8X20)	4		
86	478 560	Screw - Vite - Vis (TE M8X80)	1		
87	487 307	Pipe - Tubo - Tuyau	1		
88	482 869	Screw - Vite - Vis (TE M8X60°)	2		
89	471 365	Screw - Vite - Vis (TE M10X40)	3		

3/3	ENGINE AND POWER SHIFT COOLING SYSTEM,AIR FILTER AND EXHAUST RAFFREDDAMENTO MOTORE E CAMBIO, SCARICO FILTRO ARIA REFROIDISSEMENT DU MOTEUR ET POWER SHIFT, POT D'ECHAPPEMENT ET FILTRE AIR			2/B	
				Qty - Q.te Quantità	
Ref. Rif. Rep.	Part Number	Description Descrizione Designation	MVT 730		
90	471 326	Washer - Rondella - Rondelle	5		
91	471 325	Nut - Dado - Ecrou (M10)	3		
92	487 800	Casing - Carter - Tôle de fermeture	1		
93	487 796	Casing - Carter - Tôle de fermeture	1		
94	499 941	Indiacateur - Indicatore - Indicateur	1		
95	499 617	Pipe - Tubo - Tuyau	1		
96	499 938	Cap - Coperchio - Couvercle	1		
97	499 934	Body - Corpo - Corp	1		

Manitou Mvt730 Parts Sec Wat

Full download: <http://manualplace.com/download/manitou-mvt730-parts-sec-wat/>

2/C

A PARTIRE DALLA MACCHINA
A PARTIR DE LA MACHINE
FROM MACHINE

+ 4510 - 97620
4511 - 97621

FINO ALLA MACCHINA
JUSQU'A LA MACHINE
UP TO MACHINE

MVT 730

→ N° 4612 - 97055

→ N° 4893 - 100965

