

Manitou Access Platform 165 Atj Service Sec Wat

www.maskinisten.net

Full download: <http://manualplace.com/download/manitou-access-pl>



**BP 249 Z. I.
44 158 ANCENIS CEDEX FRANCE
TEL : +33 (0)2 40 09 10 11**

YOUR CONCESSIONARY

REF : 547 343 EN (01 / 02)

ACCESS PLATFORM 165 ATJ

REPAIRS MANUAL

This is the cut pages sample. Download all 362 page(s) at: [Manual](#)

1st ISSUE DATE

01 / 2002

CATALOGUE INFORMATION

ISSUE DATE

OBSERVATION

CATALOGUE INFORMATION	ISSUE DATE	OBSERVATION

TABLE OF CONTENTS

Groups	Chapters
0	General points
0-1-M.53 EN	Technical characteristics
10	I.C. engine
10-2-12-M.53 EN	Removing 900 series engine
10-3-12 EN	Dismantling 900 series engine
30	Axle
30-2-43-M.53 EN	Removing the front and rear axle assembly
55	Arm - Platform
55-2-20-M.53 EN	Removing the hydraulic hoses situated in the arms, pads and telescope
55-8-23-M.53 EN	Adjusting the platform overload springs and the load detection unit
70	Hydraulics
70-2-44-M.53 EN	Removing the basket and turret rotation engine
70-2-60-M.53 EN	Removing the lifting cylinders
70-2-61-M.53 EN	Removing the tilt cylinder
70-2-63-M.53 EN	Removing the telescope cylinder
70-2-64-M.53 EN	Removing the compensation cylinder
70-2-70-M.53 EN	Removing the axle locking cylinder (oscillation)
70-2-73-M.53 EN	Removing the pendular cylinder
70-5-M.53 EN	Hydraulic pressure
70-6-M.53 EN	Hydraulic diagram
75	Hydrostatic
75-2-5-M.53 EN	Removing the hydrostatic pump

TABLE OF CONTENTS

Groups

Chapters

75-3-5 EN	Removing of the hydrostatic pump A10VG
75-3-24 EN	Dismantling of the hydrostatic motor A2F
75-8-5-M.53 EN	Adjusting the hydrostatic pump
80	<i>Electricity</i>
80-2-10-M.53 EN	Replacing the electronic baseboard and microprocessor
80-8-81-M.53 EN	Position of the sensors
80-8-82-M.53 EN	Main electricity cabinet
80-8-84-M.53 EN	Parameterization of the machine

GROUPS 0

GENERAL POINTS

TECHNICAL CHARACTERISTICS

165 ATJ

0-1-M.53 EN

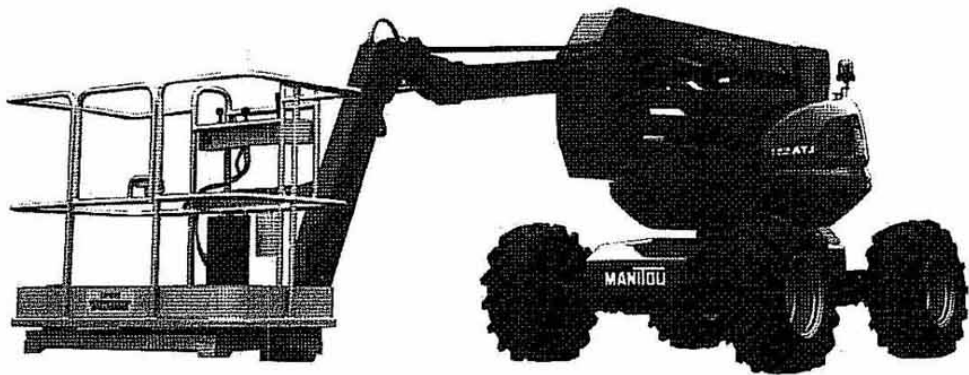

CHARACTERISTICS

ENGINE

- Type
- Number of cylinders
- Number of strokes
- Injection system
- Ignition sequence
- Rocker arm clearance (hot)
 - . Inlet
 - . Exhaust
- Capacity
- Bore
- Stroke
- Volumetric ratio
- Nominal running speed
- Idle speed
- Full speed
- Power BS.AU 141 to 1971
- Power ISO/TR 14396
- Power ISO 3046-1 : 1995
- Maximum torque
- Air cleaner

PERKINS 903-27 diesel

3 in line
4
Direct
1.2.3.

0,20 mm
0,45 mm
2700 cm³
95 mm
127 mm
17.5:1
2100 rpm
1200 rpm
2310 rpm
39,5 kw (2100 rpm)
38,5 kw (2100 rpm)
37 kw (2100 rpm)
190 Nm (1200 rpm)
Dry 3 microns

COOLING CIRCUIT

- Type
- Fan
 - . Number of blades
 - . Diameter
- Thermostat
 - . Start opening
 - . Full opening

By water
Suction
6
406,4 mm

80 / 84°C
96°C

ELECTRIC CIRCUIT

- Earth
- Battery
- Alternator
- Tension regulator
- Starter

Négative
12 V - 105 A
14 V - 55 A
Built into the alternator
12 V - 2,2 kw

HYDROSTATIC TRANSMISSION

HYDROSTATIC PUMP

- Type
- Gear reverser
- Main pump
 - . MAX. displacement
 - . MINI. displacement
 - . MAX. flow rate
 - . Working pressure
- Boost pump
 - . Cubic capacity
 - . MAX. flow rate
 - . Boost pressure MAX. r.p.m.
- Filtration
 - . Suction

A10VG45 variable displacement with
automatic power regulation
12V electromagnetic

45 cm³
0 cm³
94 L/min
350 Bar

8,4 cm³
17,64 L/min
25 Bar (Neutral transmission).

10 Microns

HYDROSTATIC ENGINE

- Type

A2FM à cylindrée fixe

AUXILIARY HYDRAULIC CIRCUIT

- Pump type	Gear pump
. Displacement	22 cm ³
- Lifting circuit, tilt, telescope, steering, rotation	
. Flow rate at full speed unladen	46 L/min
. Pressure	200 Bar
- Filtration	
. Pressure	10 Microns

BOARD FUSES

BOARD 1

- F1	10A
- F2	10A
- F3	10A
- F4	10A
- F5	3A
- F6	1A

BOARD 2

- F1	16A
- F2	16A
- F3	3,15A

165 ATJ

SPECIFICATIONS

- Use	Interior and exterior
- Capacity	250 Kg including 2 persons
- Weight of on-board fittings allowed :	
. With one person in the basket	170 kg
. With two persons in the basket	90 kg
- Hydrostatic transmission	4 drive wheels 4 steering wheels
- Turret rotation	Continuous
- Travel speed of the access platform	
. Forward	0 to 6 km/h
. Reverse	0 to 6 km/h
- Working height	16 600 mm
- Floor height	14 600 mm
- Offset maxi	10 443 mm
- Access platform weight	
. Unladen	8450 Kg
. Rated load	8700 Kg
- Number of speed	2
- Maximum slope	35%
- Ground clearance under chassis	447 mm
- Ground clearance under axle	375 mm
- Maximum authorized wind speed	45 km/h
- Admissible maximum tipping	9% or 5°
- Maximum allowed horizontal manual force	40 daN
- 1 daN = 1kg	

FRONT AND REAR TYRES

DIMENSIONS	PRESSURE	LOADED BY		WITH MAX; LOAD +, OFFCENTRING ON 1 WHEEL
		PNEUMATIC	UNLOADED	
400 / 70 - 20	Mousse	AR	AV	5600 kg
		4405Kg	4045Kg	

DIMENSIONS 165 ATJ

	165 ATJ
A	7310
A1	5450
B	2100
C	2342
C1	2380
D	2360
E	447
F	375
G	1321
H	3667
J	3841
K	6476
L	2733

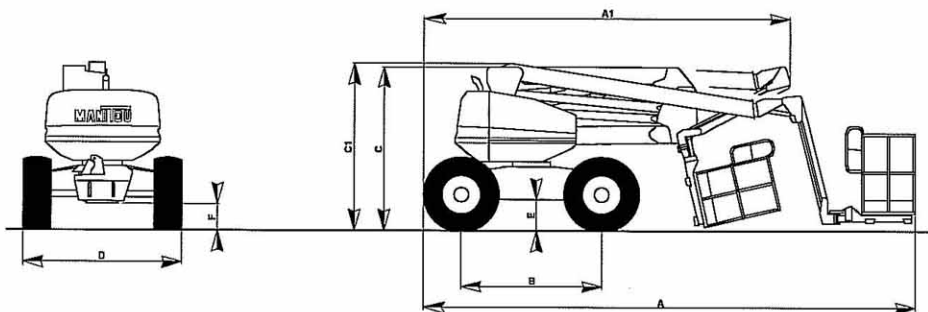
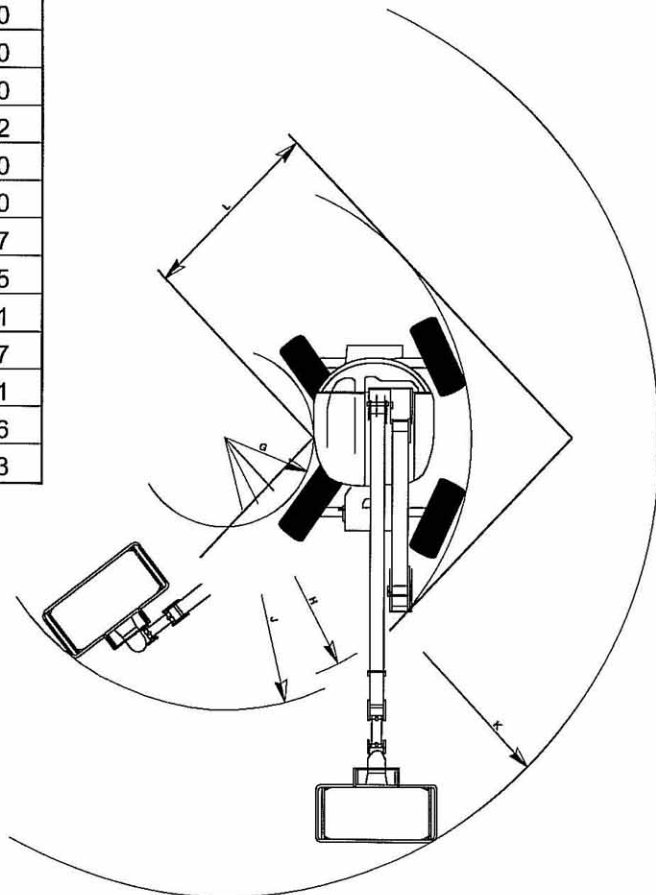

3	2	1	0	1	2	3	4	5	6	7	8	9	10	11	12
															18
															17
															16
															15
															14
															13
															12
															11
															10
															9
															8
															7
															6
															5
															4
															3
															2
															1
3						2	3								10
															11
															12

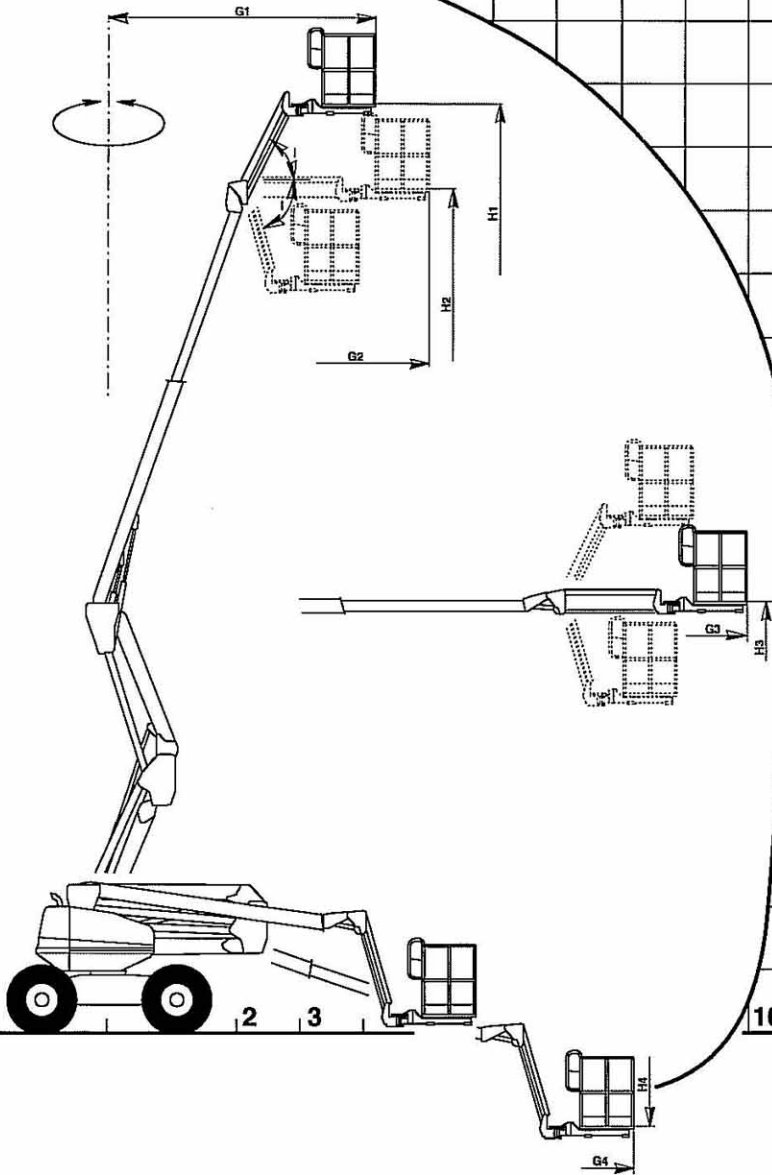

FILTERING ELEMENTS AND BELTS

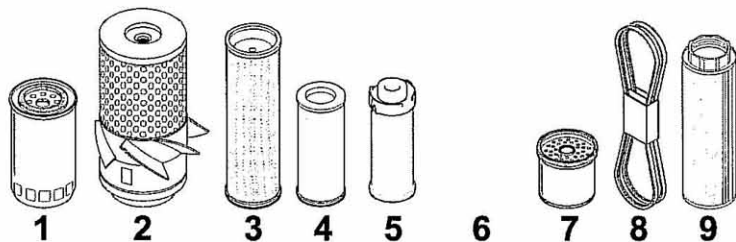

DESIGNATION	REFERENCE	CLEAN	CHANGE
1 - Thermic engine oil filter	211 384		400 H
2 - Dry air filter cartridge	177 129	50 H	400 H
3 - Safety dry air filter cartridge	177 178		800 H
4 - Hydrostatic transmission oil filter cartridge <i>(UP TO MACHINE 503 789)</i>	519 856		800 H
Hydrostatic transmission oil filter cartridge <i>(FROM MACHINE 503 790)</i>	518 250		800 H
5 - Auxiliary hydraulic oil filter cartridge	518 251		400 H
6 - Diesel Pre-filter	592 385		400 H
7 - Fuel filter cartridge	49 660		400 H
8 - Fan belt	561 299		
9 - Suction strainer for hydraulic oil tank	77 402	800 H	

GROUPS 10

I.C. ENGINE

REMOVING 900 SERIES ENGINE
165ATJ
10-2-12-M.53 EN

- Put out the crankcase:

- unscrew the nuts mark. 1 (Fig. A) of the hinges and of the pneumatic spring in order to free the crankcase.(10 mm wrench).
- dismantle the reinforcing piece mark 3 (Fig. A) in order to free the place. (13 mm wrench)

- Cut out the power supply (batterie cut out).**- Mark and disconnect the electric power supply:**

- alternator, starter, water temperature sensor, preheating, engine oil pressure, engine stop...

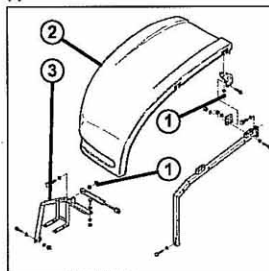
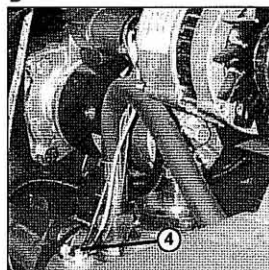
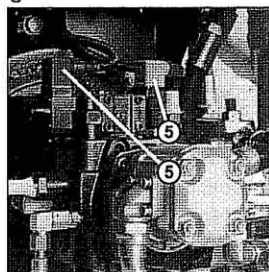
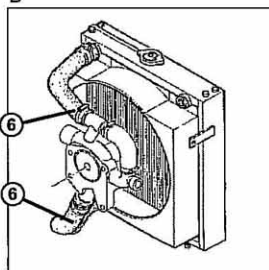
- Plug out the earth wire mark 4 (Fig. B) near the alternator. (13 mm wrench)**- Plug out the electric plug rep. 5 (Fig. C) of the hydrostatic pump with a screwdriver.****- Place a receptable under the frame und put out the water hoses mark 6 (Fig. D).****A****B****C****D**

- Dismantle the clip mark. 7 (Fig. E) and free the connection piece from its place.

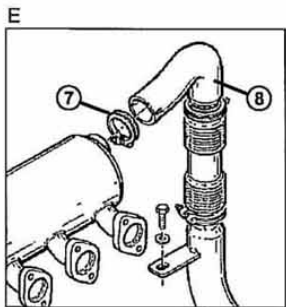

- Mark the seven hoses mark 9 (Fig. F), plug them out and seal them.

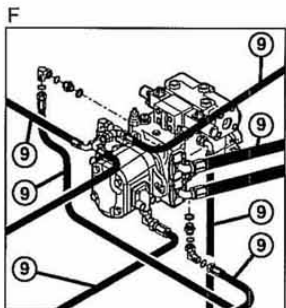

- Mark the feed hoses and back on the tank rep. 10 (Fig. G).

- Plug them out and seal them. (17 mm wrench)

- Put out the screw of the engine supports, 2 front (Fig. H) and 2 rear (Fig. I). (24 mm wrench).

- Sling the engine on the support clips mark 11 (Fig. J) designed for that purpose.

- Lightly lift the engine, .move the whole in order to free the radiator fan propeller. The engine can be put down.

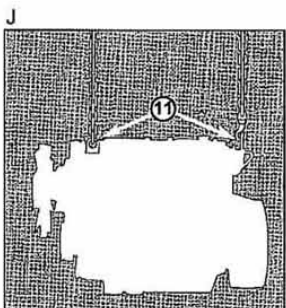
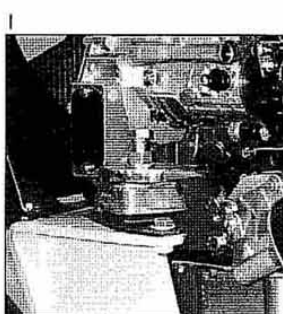
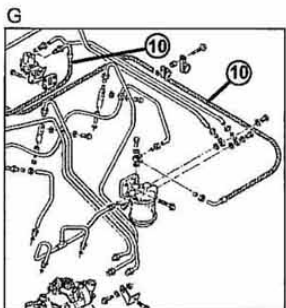

DISMANTLING 900 SERIES ENGINE
165ATJ
10-3-12 EN

Perkins 900 Series

WORKSHOP MANUAL

**3 cylinder, naturally aspirated, diesel engine for
agricultural and industrial use**

*This publication is written in
Perkins Approved Clear English*

PACE

Publication TPD 1345E, Issue 1.

(c) Proprietary Information of Perkins Group Limited 1996, all rights reserved.

Published in January 1996 by Technical Publications,

Perkins International Limited, Peterborough PE1 5NA, England

Amendment status

Edition number	Description	Date