

# E7 ENGINE OVERHAUL

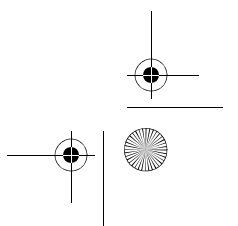

AUGUST 1997  
ENGINE 5-101

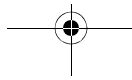

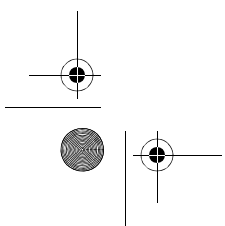
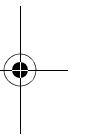
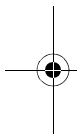
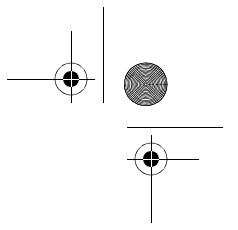
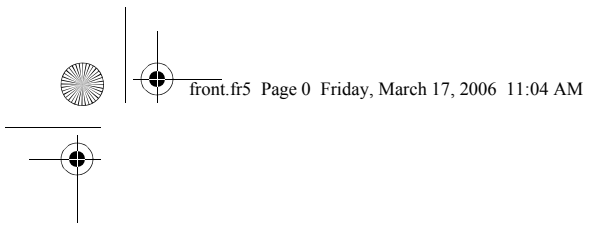

## PLEASE LET US KNOW!

Your comments and suggestions will help us improve this manual!

Please complete and mail this form or FAX your comments to: (610) 709-3800.

Manual: \_\_\_\_\_ Publication Number: \_\_\_\_\_

Vehicle Model: \_\_\_\_\_ Model Year: \_\_\_\_\_

Do you find procedures properly organized and easy to follow?  Yes  No

If not, please explain: \_\_\_\_\_

\_\_\_\_\_

Manual page numbers: \_\_\_\_\_

Are there any important procedures or other information presently not in this manual that you would like to see included?  Yes  No

If yes, please describe: \_\_\_\_\_

\_\_\_\_\_

Did you find any errors in the procedures or illustrations?  Yes  No

If yes, what pages? \_\_\_\_\_

Please explain: \_\_\_\_\_

\_\_\_\_\_

Please include a copy of each page in question and mark your comments and suggestions.

Name: \_\_\_\_\_ Phone: (\_\_\_\_\_) \_\_\_\_\_ - \_\_\_\_\_

Company: \_\_\_\_\_

Address: \_\_\_\_\_

City: \_\_\_\_\_ State: \_\_\_\_\_ Zip: \_\_\_\_\_

Position Title: \_\_\_\_\_

***Thank You For Your Assistance***  
**Mack Trucks, Inc.**

(ATTENTION: RTS STAFF, 6S3)

**DO NOT STAPLE — USE TRANSPARENT TAPE**

FOLD ALONG THIS LINE • DO NOT STAPLE • USE TRANSPARENT TAPE

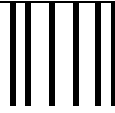

NO POSTAGE  
NECESSARY  
IF MAILED  
IN THE  
UNITED STATES

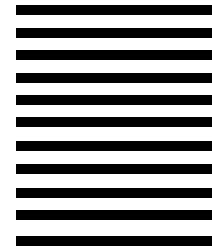

**BUSINESS REPLY MAIL**  
FIRST CLASS MAIL PERMIT NO. 1602 ALLENTOWN, PA

POSTAGE WILL BE PAID BY ADDRESSEE  
SERVICE PUBLICATIONS (RTS), 6S3  
MACK TRUCKS INC  
WORLD HEADQUARTERS  
PO BOX M  
ALLENTOWN PA 18105-9972



FOLD ALONG THIS LINE



---

# E7 ENGINE **OVERHAUL**

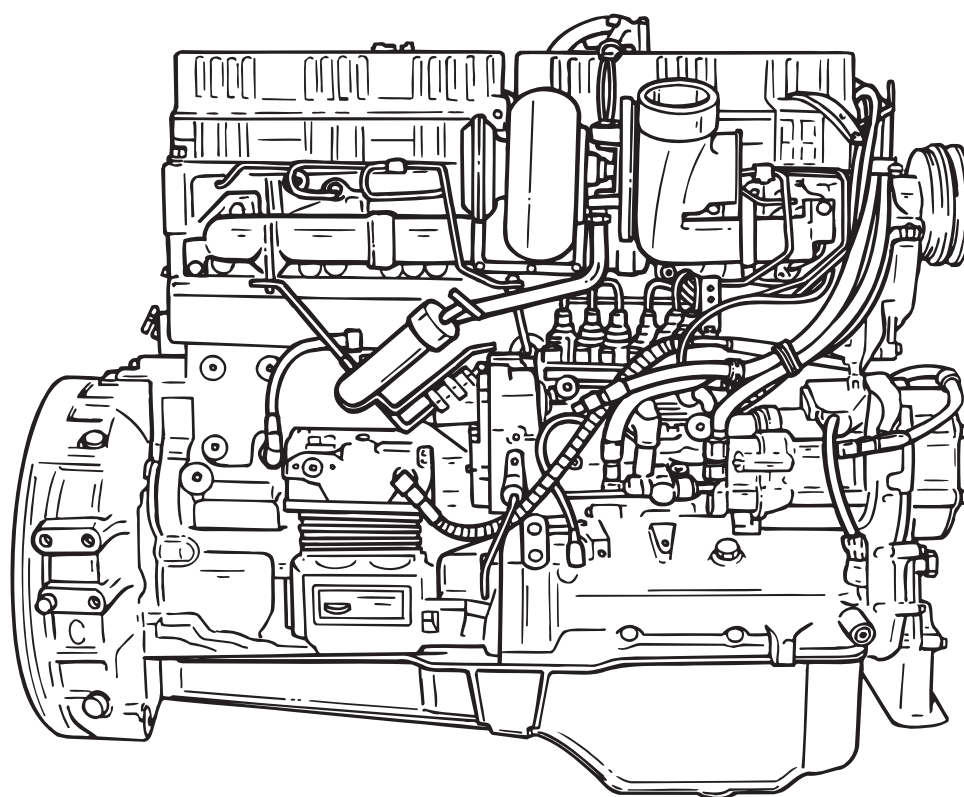

MARCH 2006 2.5M (REP.)  
AUGUST 1997 10M

© MACK TRUCKS, INC. 1997  
ENGINE 5-101

---



## ATTENTION

The information in this manual is not all inclusive and cannot take into account all unique situations. Note that some illustrations are typical and may not reflect the exact arrangement of every component installed on a specific chassis.

The information, specifications, and illustrations in this publication are based on information that was current at the time of publication.

No part of this publication may be reproduced, stored in a retrieval system, or be transmitted in any form by any means including electronic, mechanical, photocopying, recording, or otherwise without prior written permission of Mack Trucks, Inc.



# SAFETY INFORMATION

---

# SAFETY INFORMATION



## SAFETY INFORMATION

---

### Advisory Labels

Cautionary *signal words* (Danger-Warning-Caution) may appear in various locations throughout this manual. Information accented by one of these signal words must be observed to minimize the risk of personal injury to service personnel, or the possibility of improper service methods which may damage the vehicle or render it unsafe. Additional Notes and Service Hints are utilized to emphasize areas of procedural importance and provide suggestions for ease of repair. The following definitions indicate the use of these advisory labels as they appear throughout the manual:

**⚠ CAUTION**

*Directs attention to unsafe practices which could result in damage to equipment and possible subsequent personal injury or death if proper precautions are not taken.*

---

**⚠ WARNING**

**Directs attention to unsafe practices which could result in personal injury or death if proper precautions are not taken.**

---

**⚠ DANGER**

***Directs attention to unsafe practices and/or existing hazards which will result in personal injury or death if proper precautions are not taken.***

---

**NOTE**

An operating procedure, practice, condition, etc., which is essential to emphasize.

---

**SERVICE HINT**

A helpful suggestion which will make it quicker and/or easier to perform a certain procedure, while possibly reducing overhaul cost.

---

000001a





## SAFETY INFORMATION

---

### Service Procedures and Tool Usage

Anyone using a service procedure or tool not recommended in this manual must first satisfy himself thoroughly that neither his safety nor vehicle safety will be jeopardized by the service method he selects. Individuals deviating in any manner from the instructions provided assume all risks of consequential personal injury or damage to equipment involved.

Also note that particular service procedures may require the use of a special tool(s) designed for a specific purpose. These special tools must be used in the manner described, whenever specified in the instructions.

#### **WARNING**

1. **Before starting a vehicle, always be seated in the driver's seat, place the transmission in neutral, be sure that parking brakes are set, and disengage the clutch.**
  2. **Before working on a vehicle, place the transmission in neutral, set the parking brakes, and block the wheels.**
  3. **Before towing the vehicle, place the transmission in neutral and lift the rear wheels off the ground, or disconnect the driveline to avoid damage to the transmission during towing.**
- 

**REMEMBER,  
SAFETY . . . IS NO ACCIDENT!**



## SAFETY INFORMATION

---

Mack Trucks, Inc. cannot anticipate every possible occurrence that may involve a potential hazard. Accidents can be avoided by recognizing potentially hazardous situations and taking necessary precautions. Performing service procedures correctly is critical to technician safety and safe, reliable vehicle operation.

The following list of general shop safety practices can help technicians avoid potentially hazardous situations and reduce the risk of personal injury. **DO NOT** perform any services, maintenance procedures or lubrications until this manual has been read and understood.

- Perform all service work on a flat, level surface. Block wheels to prevent vehicle from rolling.
- **DO NOT** wear loose fitting or torn clothing. Remove any jewelry before servicing vehicle.
- **ALWAYS** wear safety glasses and protective shoes. Avoid injury by being aware of sharp corners and jagged edges.
- Use hoists or jacks to lift or move heavy objects.
- **NEVER** run engine indoors unless exhaust fumes are adequately vented to the outside.
- Be aware of hot surfaces. Allow engine to cool sufficiently before performing any service or tests in the vicinity of the engine.
- Keep work area clean and orderly. Clean up any spilled oil, grease, fuel, hydraulic fluid, etc.
- Only use tools that are in good condition, and always use accurately calibrated torque wrenches to tighten all fasteners to their specified torques. In instances where procedures require the use of special tools which are designed for a specific purpose, use only in the manner described in the instructions.



# EXPLANATION OF NUMERICAL CODE

---

# EXPLANATION OF NUMERICAL CODE



## EXPLANATION OF NUMERICAL CODE

### EXPLANATION OF 3-DIGIT NUMERICAL CODE

The organization of MACK service manuals has been upgraded to standardize manual content according to a reference system based on component identification. The new reference system will help link the information contained in this publication with related information included in other MACK service/warranty publications, such as associated service bulletins, warranty manuals, and the TS477 Service Labor Time Standards Manual.

The system is based on a numerical code, the first **digit** of which identifies the general component grouping as listed here:

- GROUP 000 — INSPECTIONS
- GROUP 100 — CHASSIS
- GROUP 200 — ENGINE
- GROUP 300 — CLUTCH, TRANSMISSION, TRANSFER CASE AND PTO

GROUP 400 — STEERING, AXLES, WHEELS AND TIRES, DRIVELINE

GROUP 500 — BRAKES, AUXILIARY SYSTEMS

GROUP 600 — CAB, TRUCK BODY

GROUP 700 — ELECTRICAL

The second two digits of the 3-digit code are used to identify the **system, assembly or subassembly**, as appropriate, within each of the groupings. The codes applicable to this publication are shown at the TOP OF EACH PAGE and at SECTION HEADINGS, as necessary, and may also appear in the TABLE OF CONTENTS, to guide you to specific component information.

Additionally, a two-character alpha code (i.e. [NV] RINGS, PISTON) is shown with each operation. This alpha code, in combination with the three-digit Group number, identifies the specific assembly, subassembly or part, and directly relates to the first five positions of the operation code listed in the Service Labor Time Standards Manual, TS477.

#### Examples:

#### Base Operation

Cylinder Block Moving Parts

Rings, Piston

MACK E7

Replace (one piston)

212

NV

2J

53

200976a



## ABOUT THIS MANUAL

---

## ABOUT THIS MANUAL



## ABOUT THIS MANUAL

---

### CHANGES FROM THE EXISTING E7 MANUAL

Mack Trucks, Inc. has made many major improvements to this E7 Service Manual, with changes to both content and organization. The specifications have been revised to reflect changes and improvements in E7 engines.

All specifications and torque values are given in English and metric measurements. Torque values are also included in the text, eliminating the need to refer to the Fits and Limits chart each time a specified torque value is required. The Special Tools list has been revised to include new special tools. Warnings, cautions, notes and service hints help the technician service the engine safely and efficiently.

The ENGINE DISASSEMBLY section shows how to remove components in an order that requires the least amount of handling. It includes brief component descriptions and information needed to properly service that component.

The BENCH PROCEDURES section guides the technician in disassembly, cleaning, inspection and assembly of each component. It also helps in determining if the part is serviceable or should be replaced. This section alerts the user to component upgrades and helps the technician to decide whether to use the latest available parts or reinstall existing parts. Precise descriptions aid in component identification.

The ENGINE ASSEMBLY section includes step-by-step procedures for reassembling the engine. This helps to ensure proper installation and longer service life.

The SETUP AND ADJUSTMENTS section has the latest setup information, complete with charts showing necessary data for adjusting all E7 engine models. Engines perform best and conserve fuel most efficiently when adjusted properly.

Two additional sections are included as guides for removing and reinstalling the engine. Both sections are generic in nature. E7 engine installation procedures vary from one vehicle style to another. These procedures are intended as a checklist to remind the technician of all necessary tasks.

While troubleshooting procedures are similar for most diesel engines, this manual includes only those that pertain to the E7 engine. The TROUBLESHOOTING section contains questions to help the technician consider all possible problem sources.

This service manual has been revised to include all applicable active service bulletins and service letters since publication of the earlier E7 Service Manual (October 1992).



# TABLE OF CONTENTS

---

# TABLE OF CONTENTS



## TABLE OF CONTENTS

<b>SAFETY INFORMATION</b> .....	iii
Advisory Labels .....	iv
Service Procedures and Tool Usage .....	v
<b>EXPLANATION OF NUMERICAL CODE</b> .....	vii
EXPLANATION OF 3-DIGIT NUMERICAL CODE .....	viii
<b>ABOUT THIS MANUAL</b> .....	ix
<b>200 GENERAL INFORMATION</b> .....	1-1
INTRODUCTION .....	1-2
ENGINE MODEL IDENTIFICATION .....	1-3
Engine Information Plate .....	1-3
LUBRICANTS AND SEALANTS .....	1-5
OVERHAUL PART REPLACEMENT .....	1-6
<b>200 SPECIFICATIONS</b> .....	2-1
SPECIFICATIONS .....	2-2
Improved Design .....	2-2
Engine General Specifications .....	2-2
Engine Features .....	2-2
Good Shop Practice — Fasteners .....	2-4
Performance Specifications (Oil Pressure and Intake Manifold Temperature) .....	2-4
FASTENER TORQUE .....	2-5
Fastener Selection and Installation .....	2-5
Fastener Sizes and Types .....	2-6
TORQUE SPECIFICATIONS .....	2-7
Torque Specifications for Critical Fasteners .....	2-7
Torque Specifications for Hose Clamps .....	2-10
Torque Specifications for Pipe Plugs .....	2-11
Torque Specifications for Non-Critical Fasteners .....	2-11
FITS AND LIMITS .....	2-14
Fits and Limits .....	2-14
METRIC MISMATCH .....	2-20
Inch Thread vs. Metric Thread Fastener Combinations Contributing to Thread Stripping .....	2-20
Inch Thread vs. Metric Thread Fastener Combinations Contributing to Assembly Weakness .....	2-21
Incompatible Metric vs. Metric Fastener Systems .....	2-21
CONVERSION FACTORS .....	2-21
SPECIAL TOOLS .....	2-22
Special Tool List .....	2-22
V-MAC Tools .....	2-24
<b>200 ENGINE REMOVAL</b> .....	3-1
GENERAL .....	3-2
Vehicle Preparation .....	3-2
Engine Removal .....	3-2
<b>200 ENGINE DISASSEMBLY</b> .....	4-1
GENERAL .....	4-2
[219 EV] CENTRI-MAX™ AND SPIN-ON FILTER ELEMENTS .....	4-2
MOUNTING ENGINE IN STAND .....	4-3
Special Tools Required .....	4-3
[271 CB] ALTERNATOR .....	4-5
[215 HB] FAN ASSEMBLY .....	4-5





## TABLE OF CONTENTS

[231 PB] FUEL FILTER ADAPTER ASSEMBLY .....	4-6
[215 LD] COOLANT CONDITIONER ELEMENT .....	4-7
[215 NU] THERMOSTAT .....	4-8
[214 HD] AIR INLET MANIFOLD .....	4-9
[215 NK] COOLANT MANIFOLD .....	4-9
[215 DW & 219 EP] OIL COOLER AND OIL FILTER HOUSING ASSEMBLY .....	4-10
[215 SW] WATER PUMP .....	4-11
[214 SD] TURBOCHARGER .....	4-11
[222 KD] FUEL NOZZLE INLET TUBE ASSEMBLY .....	4-12
[214 EG] EXHAUST MANIFOLD .....	4-13
[213 JB] VALVE COVER AND RISER .....	4-13
[213 LP, NV & LH] ROCKER ARM, VALVE YOKE AND PUSH ROD .....	4-14
[222 KG] NOZZLE HOLDER .....	4-15
Special Tool Required .....	4-15
[213 EV] CYLINDER HEAD ASSEMBLY REMOVAL .....	4-16
[212 RB & RH] VIBRATION DAMPER AND CRANKSHAFT HUB .....	4-17
[261 CK] AIR COMPRESSOR .....	4-17
[221 GP] INJECTION PUMP .....	4-19
[221 CD] ECONOVANCE .....	4-20
V-MAC Equipped Engines .....	4-20
[211 NB] OIL PAN .....	4-20
[219 MU] OIL PUMP .....	4-22
[211 RP] TIMING GEAR COVER .....	4-23
[212 CV] AUXILIARY DRIVESHAFT .....	4-24
[213 CH] CAMSHAFT .....	4-24
[212 NP & LQ] PISTON AND CONNECTING ROD ASSEMBLY .....	4-25
[212 UC] FLYWHEEL .....	4-27
[211 HD] FLYWHEEL HOUSING .....	4-28
[211 JA] MAIN BEARING CAP .....	4-28
[212 HP] CRANKSHAFT .....	4-30
[219 RV] PISTON COOLING SPRAY NOZZLE .....	4-30
[212 NC] CYLINDER SLEEVE .....	4-31
Special Tool Required .....	4-31
<b>200 BENCH PROCEDURES .....</b>	<b>5-1</b>
[211 DB] CYLINDER BLOCK .....	5-2
Cylinder Sleeve Counterbore .....	5-2
[212 CV] AUXILIARY DRIVESHAFT .....	5-5
Description .....	5-5
Inspection .....	5-5
[212 LP] CONNECTING RODS .....	5-5
Description .....	5-5
Special Tools Required .....	5-7
Inspection .....	5-7
Wrist Pin Repair .....	5-7
[212 HP] CRANKSHAFT .....	5-9
Description .....	5-9
Inspection .....	5-10
[212 HA] Crankshaft Dowel Pin Replacement .....	5-10
[212 HV] Crankshaft Gear .....	5-12
[212 UB] FLYWHEEL .....	5-13



## TABLE OF CONTENTS

[212 NP] PISTONS .....	5-13
Description .....	5-13
Special Tools Required .....	5-14
Disassembly .....	5-14
Inspection .....	5-15
[212 NV] PISTON RINGS .....	5-15
Keystone Ring Groove Check .....	5-15
Ring Installation .....	5-17
[212 LP & NP] CONNECTING ROD ASSEMBLY TO PISTON .....	5-17
[213 CH] CAMSHAFT .....	5-18
Description .....	5-18
Disassembly .....	5-18
Inspection .....	5-20
Assembly .....	5-20
[213 EV] CYLINDER HEADS .....	5-22
Description .....	5-22
Special Tools Required .....	5-24
[213 NB] Inlet and Exhaust Valve Removal .....	5-25
[213 EX] Cylinder Head Inspection .....	5-27
[213 EH] Fire Ring Groove .....	5-27
[213 EP] Valve Guides .....	5-30
[213 FB] Inlet and Exhaust Valve Seat Inserts .....	5-33
[213 MB] Valve Springs .....	5-38
[213 GB] Injection Nozzle Holder Insert .....	5-38
[213 FH] Valve Yoke Guide Pins .....	5-39
[213 FP] Cylinder Head Cup Plugs .....	5-41
Cylinder Head Pipe Plugs .....	5-42
[213 NB] INLET AND EXHAUST VALVES .....	5-43
Inspection .....	5-43
Valve Identification .....	5-43
Inlet and Exhaust Valve Installation .....	5-45
[213 LV] VALVE ROCKER ARM SHAFT .....	5-47
Inspection .....	5-47
Rocker Arms .....	5-47
Valve Rocker Arm Shaft Assembly (Except Jacobs Engine Brake) .....	5-47
Valve Rocker Arm Shaft Assembly (with Jacobs Engine Brake) .....	5-49
Dynatard Engine Brake Solenoid .....	5-51
[266 KD] DYNATARD ENGINE BRAKE .....	5-51
Dynatard Overload Protection (E7 Engines with Dynatard) .....	5-51
Dynatard Overload Protection System .....	5-52
[266] JACOBS® ENGINE BRAKE .....	5-53
[266] ENGINE BRAKE SWITCH AND BRACKET ASSEMBLY .....	5-53
Description .....	5-53
Adjustment (E7 Mechanically Governed Engine with Engine Brake) .....	5-53
[215 DW] OIL COOLER ASSEMBLY .....	5-54
Description .....	5-54
Disassembly .....	5-55



## TABLE OF CONTENTS

Inspection .....	5-56
Assembly .....	5-56
[215 SW] WATER PUMP .....	5-57
[219 MU] OIL PUMP .....	5-57
Disassembly .....	5-57
Inspection .....	5-58
Improved "Fast Ratio" Auxiliary Driveshaft .....	5-61
Assembly .....	5-62
[221 CD] ECONOVANCE .....	5-62
Econovance Control Valve Assembly .....	5-62
Econovance Disassembly .....	5-63
Cleaning and Inspection .....	5-64
Econovance Assembly .....	5-64
[221 KU] INJECTION PUMP DRIVE HUB .....	5-64
Description .....	5-64
Special Tools Required .....	5-64
Cleaning .....	5-65
Installation of Drive Hub (Mechanically Governed Engines) .....	5-65
Installation of Drive Hub (V-MAC Engines) .....	5-66
[222 KG] INJECTOR NOZZLES .....	5-67
Nozzle Cleaning .....	5-67
<b>200 ENGINE ASSEMBLY .....</b>	<b>6-1</b>
GENERAL .....	6-2
[211 DB] CYLINDER BLOCK .....	6-2
Special Tools Required .....	6-2
Cleaning and Inspection .....	6-2
Cup Plug Replacement .....	6-3
Pipe Plug Replacement .....	6-4
[213 CC] Camshaft Bushings .....	6-5
[212 CB] Auxiliary Driveshaft Bushing Replacement .....	6-9
[212 NC] CYLINDER SLEEVE .....	6-11
Description .....	6-11
Special Tools Required .....	6-11
Installation .....	6-11
[219 RV] PISTON COOLING SPRAY NOZZLE .....	6-14
Description .....	6-14
Special Tools Required .....	6-14
Installation .....	6-14
Piston Cooling Nozzle Spray Positioning .....	6-15
[211 HA] CYLINDER BLOCK DOWEL PINS .....	6-17
Description .....	6-17
Special Tools Required .....	6-17
Removal .....	6-17
Installation .....	6-17
[212 HP] CRANKSHAFT .....	6-19
Installation .....	6-19
[212 HH] MAIN BEARING CAP .....	6-20
Special Tool Required .....	6-20
Installation .....	6-20



# TABLE OF CONTENTS

[212 NP & 212 LP] PISTONS AND CONNECTING RODS .....	6-23
Description .....	6-23
Special Tools Required .....	6-23
Installation .....	6-24
[211 HD] FLYWHEEL HOUSING .....	6-26
Description .....	6-26
Inspection .....	6-26
Dowel Pins .....	6-26
Capscrews (Flywheel Housing) .....	6-27
Installation .....	6-29
Runout .....	6-30
[212 JH] CRANKSHAFT WEAR RING .....	6-31
Special Tools Required .....	6-31
Removal .....	6-31
Installation .....	6-31
Wear Ring with Double-Lip Teflon Seal (Automatic Transmission) .....	6-32
[212 JH] CRANKSHAFT REAR OIL SEAL .....	6-33
Installation .....	6-33
[212 VC] FLYWHEEL (E7 ENGINE WITHOUT POINTER ON TIMING COVER) .....	6-35
Description .....	6-35
Installation .....	6-36
[213 CH] CAMSHAFT .....	6-37
Description .....	6-37
Special Tools Required .....	6-37
Inspection .....	6-37
Installation (Engine in Stand) .....	6-38
Installation (Engine in Chassis) .....	6-39
[212 CV] AUXILIARY DRIVESHAFT .....	6-41
Inspection .....	6-41
Installation .....	6-41
[219 MU] OIL PUMP .....	6-42
Description .....	6-42
Installation .....	6-43
[211 RP] TIMING GEAR COVER .....	6-44
[211 SB] TIMING GEAR COVER SEAL .....	6-45
Special Tool Required .....	6-45
Installation .....	6-45
[221 GP] FUEL INJECTION PUMP INSTALLATION .....	6-45
[212 RH] CRANKSHAFT HUB .....	6-45
Inspection .....	6-45
Installation .....	6-45
[212 RB] VIBRATION DAMPER .....	6-46
Description .....	6-46
Inspection .....	6-46
Installation .....	6-46
[211 NB] OIL PAN .....	6-46
Description (Isolating Oil Pan Gasket on E7 Engines) .....	6-46
Oil Pan Installation .....	6-50