

LG968轮式装载机 零部件图册

LG968 WHEEL LOADER PARTS CATALOG

山东临工工程机械有限公司

SHANDONG LINGONG CONSTRUCTION MACHINERY CO.,LTD.

配件与服务 Spare parts and services

对于山东临工机器的所有者来说,只有山东临工配件和服务才能够使您的机器更好地保持原有的特性。

For the owner of the machines of SDLG,only the space parts and services of SDLG can mark your machine to better maintain the original features.

只有山东临工才能够为您提供完美匹配且优质纯正的配件和对您的机器了如指掌的专业维修人员。这样才能保证及其可持续的高产能和更长的使用寿命。

Only SDLG is able to provide you with the perfect match of pure quality spare parts for your machine and knowledge of professional maintenance staff.Only in this way it can ensure sustainable high productivity and longer service life.

LG968轮式装载机 零部件图册

LG968 WHEEL LOADER PARTS CATALOG

2009年12月 第1版 第1次印刷

2009-12 Version 1 Printed 1

山 东 临 工 程 机 械 有 限 公 司
SHANDONG LINGONG CONSTRUCTION MACHINERY CO.,LTD.

地址: 中国·临沂经济开发区临工工业园

Add: Lingong Industry Park,Linyi Economic Development Zone,Shandong,china

电话: 86-0539-8785668

Tel: 86-0539-8785624/86-0531-66590955

传真: 86-0539-8785698

Fax: 86-0539-8785618/86-0531-66590959

技术服务: 86-0539-8785800 400-6587999

Web: www.sdlg.cn

前言

LG968轮式装载机零部件图册，是为了方便用户使用、维修和保养而绘制的，以供在使用过程中查阅及参考，也可帮助用户了解本机的结构和装配关系。发动机的零部件详见其随机资料，本图册不再绘出。

本图册按系统划分绘制出了各零部件的图形及相互装配关系。凡装机后不可拆卸的部件（如焊接件、铆合件），只标出部件代号，不另列其组成零件。本图册明细表采用中英文对照编排。

本图册主要根据标准型产品(订货号E6811213A39)编绘，其它非标准配置，可参照执行，详情请咨询山东临工、或当地经销商、或登录山东临工网站查询。随着科技的进步，产品将会不断改进，故本图册的内容可能会有部分与以后的产品不一致，恕不另行通知。敬请用户在订购配件时，指明所购整车的出厂日期和编号。

编者

2009年12月

FOREWORD

THIS PARTS LIST OF LG968 WHEEL LOADER IS MADE FOR THE CONVENIENCE OF USERS TO USE , REPAIR AND MAINTAIN THE MACHINE, AND IT CAN BE REFERED IN THE PROCESS OF USING. IT CAN ALSO HELP THE USERS TO BE FAMILIAR WITH THE CONSTRUCTION AND ASSEMBLY RELATION OF THE MACHINE. THE PART OF THE ENGINE IS SHOWED IN DETAIL IN ITS STRUCTION HANDBOOK. SO THIS CATALOG DOES NOT CONTAIN THE ENGING PART LIST.

THE CATALOG CONTAINS THE PART DRAWINGS OF DEFERENT ASSEMBLIES, SHOWING THE SHAPE OF THE PARTS AS WELL AS THE ASSEMBLING RELATION. THE COMPONENTS WHICH CAN NOT BE TAKEN APART (SUCH AS THE WELDMENT OR RIVETED ASSEMBLIES) ARE INDICATED ONLY BY THEIR COMPONET NUMBERS WITHOUT THE CONSISTING PART NUMBERS . THE LIST IN THE CATALOG IS ARRANGED BY CHINESE VERSUS ENGLISH.

THIS CATALOG IS MAINLY BASED ON THE STANDARD PRODUCT (ORDER NUMBER E6811213A39) THE OTHERS OF NONSTANDARD PRODUCT CAN REFER THE STANDARD PRODUCT, AND THE DETAILED INFORMATION CAN BE KNOWN FROM SHANDONG LINGONG, THE LOACAL DEALER OR LINGONG WEBSITE ALTERATIONS IN DESIGN ARE NECESSARILY WITH THE THECHNICAL DEVELOPMENT SO SOME CONTENT IN THE CATALOG PROBABLY IS NOT CONSISTANT WITH THE FUTURE PRODUCTS, AND THIS WILL NOT NOTICE USERS. THEREFORE WHEN ORDERING SPARE PARTS, USERS ARE KINDLY REQUSETED TO INFORM US THE MANUFACTURING DATE AND BATCHNUMBER OF THE WHEEL LOADER.

THE COMPILER

2009. 12

目录 CONTENTS

A. 发动机系统

A. DIESEL ENGINE SYSTEM

发动机系统	A1-2901001456
DIESEL ENGINE SYSTEM	A1-2901001456
燃油箱总成	A2-2902000845
FUEL TANK ASSEMBLY	A2-2902000845
散热器总成	A3-2903000973
RADIATOR ASS'Y	A3-2903000973
油门操纵机构	A4-2901000752
GOVERNOR CONTROL SYSTEM	A4-2901000752
发动机	A5-4110000565
DIESEL ENGINE	A5-4110000565

B. 变矩器系统

B. TORQUE CONVERTER SYSTEM

双变总成	B1-2905001267
TRANSMISSION ASSEMBLY	B1-2905001267

C. 变速箱系统

C. TRANSMISSION SYSTEM

发动机连接总成4644 130	C2-4110000042
ENGINE CONNECT ASSEMBLY 4644 130	C2-4110000042

变矩器4166 034	C3-4110000042
CONVERTER 4166 034	C3-4110000042
输入装置4644 102	C4-4110000042
INPUT 4644 102	C4-4110000042
变速箱总成4644 101	C5-4110000042
GEARBOX HOUSING ASSEMBLY 4644 101	C5-4110000042
中间轴4644 108	C6-4110000042
LAYSHAFT 4644 108	C6-4110000042
离合器KV+K1 4644 151	C7-4110000042
COUPLNG KV+K1 4644 151	C7-4110000042
离合器KR+K2 4644 152	C8-4110000042
COUPLNG KR+K2 4644 152	C8-4110000042
离合器4644 153	C9-4110000042
COUPLNG 4644 153	C9-4110000042
输出装置4644 103	C10-4110000042
OUTPUT 4644 103	C10-4110000042
停车制动器4644 109	C11-4110000042
PARKING BRAKE 4644 109	C11-4110000042
停车制动器0501 003	C12-4110000042
PARKING BRAKE 0501 003	C12-4110000042

取力器 4644 154	C13-4110000042
POWER TAKE-OFF 4644 154	C13-4110000042
取力器4644 155	C14-4110000042
POWER TAKE-OFF 4644 155	C14-4110000042
变速调档系统4644 106	C15-4110000042
GEARSHIFT SYST 4644 106	C15-4110000042
变速调档系统4644 159	C16-4110000042
GEARSHIFT SYST 4644 159	C16-4110000042
调压阀4644 120	C17-4110000042
PRESS.REGULATOR 4644 120	C17-4110000042
过滤器4644 138	C18-4110000042
FILTER 4644 138	C18-4110000042
应急转向泵4644 137	C19-4110000042
EMCY.STEER.PUMP 644 137	C19-4110000042
感应式传感器4644 125	C20-4110000042
IND.TRANSMITTER 4644 125	C20-4110000042
注入管接头4644 131	C21-4110000042
FILLER NECK 4644 131	C21-4110000042
油管4644 121	C22-4110000042
OIL PIPES 644 121	C22-4110000042

散件4644 199	C23-4110000042
LOOSE PARTS 4644 199	C23-4110000042
E. 驱动桥系统	
E. AXLE SYSTEM	
前桥总成	E1-2907001080
FRONT AXLE ASSEMBLY	E1-2907001080
前主传动总成	E2-2907000006
FRONT AXLE MAIN DRIVE ASSEMBLY	E2-2907000006
轮边减速器(前桥)	E3-2907001091
FINAL DRIVE ASSEMBLY	E3-2907001091
传动轴总成	E4-2908000764
DRIVE SHAFT GROUP	E4-2908000764
后桥总成	E5-2909000817
REAR AXLE ASSEMBLY	E5-2909000817
后主传动总成	E6-2909000003
REAR AXLE MAIN DRIVE ASSEMBLY	E6-2909000003
制动钳(371328)	E8-4120001739
DISK BRAKE(371328)	E8-4120001739
轮胎GB2980-23.5-25 (520101)	E11-4110000006
TIRE GB2980-23.5-25 (520101)	E11-4110000006

F. 工作装置液压系统

F. IMPLEMENT HYDRAULIC SYSTEM

液压操纵总成	F1-2912001693
HYDRAULIC CONTROL ASSEMBLY	F1-2912001693
工作泵总成	F2-2911000883
WORKING PUMP ASSEMBLY	F2-2911000883
举升缸总成	F3-2913001219
LIFT ARM CYLINDER ASSEMBLY	F3-2913001219
转斗缸总成	F4-2914001008
TILT CYLINDER ASSEMBLY	F4-2914001008
液压油箱总成	F5-2910001140
HYDRAULIC TANK ASSEMBLY	F5-2910001140
转斗油缸 (371368)	F7-4120000601
TILT CYLINDER (371368)	F7-4120000601
动臂油缸 (371368)	F9-4120000600
LIFTING CYLINDER (371368)	F9-4120000600

H. 工作装置

H. WORKING EQUIPMENT

工作装置	H1-2916000776
WORKING EQUIPMENT	H1-2916000776

铲斗总成	H2-2917001364
BUCKET ASSEMBLY	H2-2917001364
I. 转向系统	
I. STEERING SYSTEM	
转向泵总成	I1-2919000788
STEERING PUMP ASSEMBLY	I1-2919000788
转向器总成	I2-2920000841
STEERING UNIT ASSEMBLY	I2-2920000841
转向缸总成	I3-2921000767
STEERING CYLINDER ASSEMBLY	I3-2921000767
转向油缸(371368)	I5-4120000602
STEERING CYLINDER(371368)	I5-4120000602
J. 制动系统	
J. BRAKE SYSTEM	
行车制动系统	J1-2922000908
SERVICE BRAKE SYSTEM	J1-2922000908
储气罐	J2-2922000053
AIR RESERVOIR	J2-2922000053
加力泵(340201)	J3-4120000675
BRAKE BOOSTER	J3-4120000675

驻车制动系统	J4-2923000751
PARKING BRAKE SYSTEM	J4-2923000751

K. 车架

K. FRAME

前车架总成	K1-2925000754
FRONT FRAME	K1-2925000754
铰接	K2-2925000001
ARTICULATION	K2-2925000001
灯架及挡泥瓦	K3-2925000001
LAMP FRAME AND FRONT FENDER	K3-2925000001
后车架及配件	K4-2926001378
REAR FRAME AND ACCESSORIES	K4-2926001378
配重铁总成	K5-2928000805
COUNTER WEIGHT	K5-2928000805

L. 驾驶室

L. CAB GROUP

驾驶室总成	L1-2929000881
CAB ASSEMBLY	L1-2929000881
驾驶室	L2-2929000916
CAB	L2-2929000916

操作台架	L3-2931001426
OPERATE BENCH	L3-2931001426
座椅总成	L4-2930000772
SEAT ASSEMBLY	L4-2930000772
操纵箱	L5-2932000957
OPERATE BOX	L5-2932000957

M. 覆盖件系统

M. CONVER SYSTEM

发动机罩总成	M1-2933001916
HOOD OF DIESEL ENGINE ASSEMBLY	M1-2933001916
左台架总成	M2-2934001541
LEFT BENCH GROUP	M2-2934001541
右台架总成	M3-2934001556
RIGHT BENCH GROUP	M3-2934001556
后转向灯罩	M4-2934001568
REAR STEERING LAMP HOOD	M4-2934001568
标志与标识	M5-2936001200
SIGN AND LOGO	M5-2936001200
电瓶箱	M6-2934001572
BATTERY CASE	M6-2934001572

工具箱	M7-2934001581
TOOL CASE	M7-2934001581
N. 空调系统	
N. AIR CONDITIONER SYSTEM	
空调系统	N2-2935000894
AIR CONDITIONER SYSTEM	N2-2935000894
O. 电气系统	
O. ELECTRIC SYSTEM	
电气系统	O1-2937001540
ELECTRIC SYSTEM	O1-2937001540
仪表盘总成	O2-2937001534
PANEL ASSEMBLY	O2-2937001534
仪表台总成	O3-2937001334
PANEL ASSEMBLY	O3-2937001334



A 发动机系统
DIESEL ENGINE SYSTEM

山东临工工程机械有限公司
SHANDONG LINGONG CONSTRUCTION MACHINERY CO.,LTD.

发动机系统 DIESEL ENGINE SYSTEM

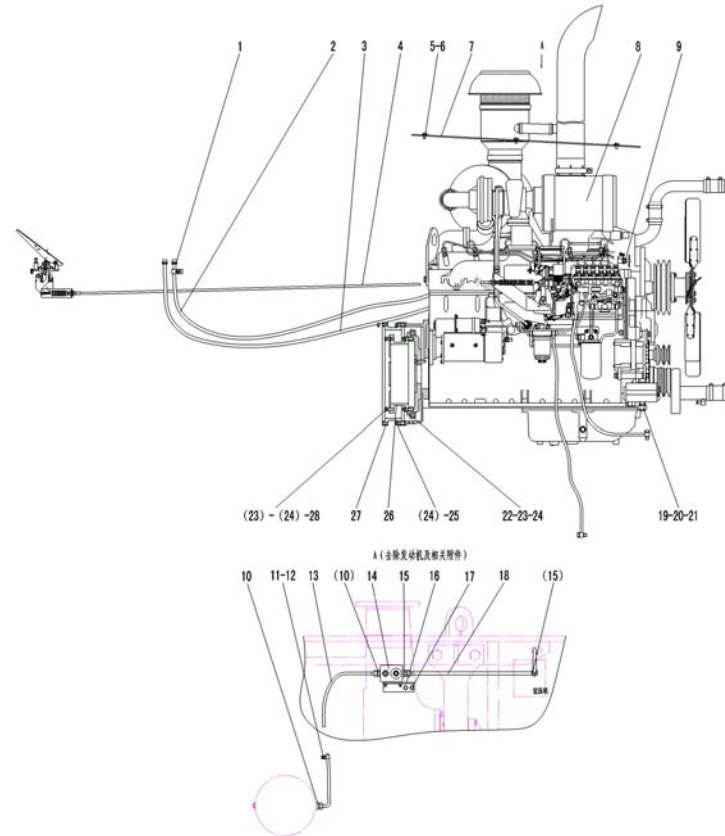

序号 Key	零件代号 Part No.	名称 Description	是否配件 Spare parts Y/N	数量 Qty	备注 Remarks
1	4017000024	环箍QC390-D26	CLAMP QC390-D26	N	4
2	4120000049	胶管JB8406-B16*2600	RUBBER TUBE JB8406-B16X2600	Y	1
3	4120000136	胶管JB8406-B16*2900	HOSE JB8406-B16*2900	Y	1
4	29010007521	油门操纵机构	GOVERNOR CONTROL SYSTEM	N	1
5	4011000081	螺栓GB5783-M10*20EpZn-8.8	BOLT GB5783-M10*20EpZn-8.8	N	7
6	4015000197	垫圈GB96.1-10EpZn-300HV	WASHER GB96.1-10EpZn-300HV	N	7
7	29010014441	上盖板	UPPER COVER PLATE	Y	1
8	4110000565	发动机总成C6121ZG61B(CB0046)	ENGINE ASSEMBLY C6121ZG61B(CB0046)	Y	1
9	4120000067	暖风机水阀LG12-NFJSF	VALVE-HEATER	Y	2
10	29220001191	直接头	CONNECTOR	Y	2
11	29010000031	管夹	CLAMP	Y	1
12	4011000461	螺栓GB16674-M8*16EpZn-8.8	BOLT GB16674-M8*16EpZn-8.8	N	2
13	4041001031	软管LGB145-205263	TUBE LGB145-205263	Y	1
14	4120000084	油水分离器组合阀ST-50G	AIR DYER ST-50G	Y	1
15	29220000171	垫圈	WASHER	Y	2
16	29010009241	支撑板	SUPPORT PLATE	Y	1
17	4011000488	螺栓GB16674-M10*16EpZn-8.8	BOLT GB16674-M10*16EpZn-8.8	N	2
18	4120000750	金属软管	METAL TUBE	Y	1

发动机系统 DIESEL ENGINE SYSTEM

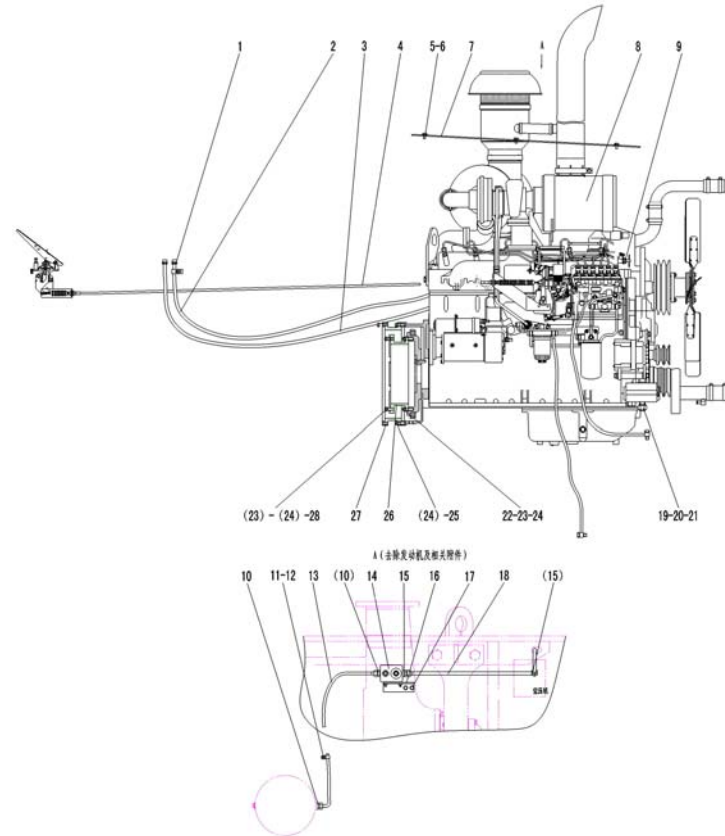

序号 Key	零件代号 Part No.	名称 Description	是否配件 Spare parts Y/N	数量 Qty	备注 Remarks
19	4011000387	螺栓GB5782-M24*130EpZn-8.8	BOLT GB5782-M24*130EpZn-8.8	N	2
20	4013000021	螺母GB6170-M24EpZn-8	NUT GB6170-M24EpZn-8	N	2
21	4015000167	垫圈GB97.1-24EpZn-300HV	WASHER GB97.1-24EpZn-300HV	N	2
22	4012000021	螺柱GB899-AM10*1-M10*35-8.8	BOLT GB899-AM10*1-M10*35-8.8	N	2
23	4013000007	螺母GB6170-M10EpZn-8	NUT GB6170-M10EpZn-8	N	16
24	4015000025	垫圈GB93-10-65Mn	WASHER GB93-10-65Mn	N	28
25	4011000085	螺栓GB5783-M10*35EpZn-8.8	BOLT GB5783-M10*35EpZn-8.8	N	12
26	29010012061	飞轮过渡	TRANSITION PAN OF FLYWHEEL	Y	1
27	29010012071	飞轮壳过渡	TRANSITION PAN OF FLYWHEEL SHELL	Y	1
28	4012000011	螺柱GB899-M10*32EpZn-8.8	BOLT GB899-M10*32EpZn-8.8	N	8



燃油箱总成 FUEL TANK ASSEMBLY

